

Worldwide Sumitomo Network

U.S.A.

Sumitomo Machinery Corporation of America (SMA)
4200 Holland Blvd.
Chesapeake, VA 23323,
U.S.A.
Tel: (1) 757-485-3355
Fax: (1) 757-487-3193

Canada

SM-Cyclo of Canada, Ltd. (SMC)
1045 South Service Road,
West Oakville Ontario,
Canada L6L 6K3
Tel: (1) 905-469-1050
Fax: (1) 905-469-1055

Mexico

SM-Cyclo De Mexico, S.A. de C.V. (SMME)
Calle "C" No. 506A Parque Industrial
Almacentro Apodaca, N. L., Mexico 66600
Tel: (52) 81-8369-3697
Fax: (52) 81-8369-3699

Brazil

SM-Cyclo Redutores Do Brasil, Ltda. (SMBR)
Av. Fagundes Filho, 191 Metro Sao Judas
Edificio Houston-Sala H123 Sao Paulo-SP
Brazil 04304-010
Tel: (55) 11-5585-3600
Fax: (55) 11-5585-9990

Chile

SM-Cyclo De Chile, Ltda. (SMCH)
San Pablo Ave, 3507 Quinta Nomal,
Santiago, Chile
Tel: (56) 2-786-6963
Fax: (56) 2-786-6964

Argentina

SM-Cyclo De Argentina S.A. (SMAR)
Montes de Oca #6719, (B1606BMG) Munro,
Buenos Aires, Argentina
Tel: (54) 11-4765-5288
Fax: (54) 11-4765-5517

United Kingdom

SM-Cyclo U.K. Ltd. (SMUK)
29 Bergen Way,
Sutton Fields Industrial Estate
Kingston upon Hull,
East Yorkshire HU7 0YQ
United Kingdom
Tel: (44) 1482-790340
Fax: (44) 1482-790321

France

SM-Cyclo France E.U.R.L. (SMFR)
65/75 Avenue Jean Mermoz
F-93126 La Courneuve,
France
Tel: (33) 149-929494
Fax: (33) 149-929490

Italy

SM-Cyclo Italy Srl (SMIT)
Via dell' Artigianato 231-20010
Cornaredo (Mi),
Italy
Tel: (39) 02-9356-2121
Fax: (39) 02-9356-9893

Netherlands

SM-Cyclo Benelux BV (SMBE)
Den Engelsman 16D NL-6026 RB
Maarheeze,
Netherlands
Tel: (31) 495599777
Fax: (31) 495593177

Sweden

SM-Cyclo Scandinavia AB (SMSC)
Ridbanegatan 4213 77 Malmö,
Sweden Postal Address: box
9178, SE-200 39 Malmö
Tel: (46) 40220030
Fax: (46) 40220035

Spain

SM-Cyclo Iberia, S.L. (SMIB)
C/Landabarri Nº4 Escalera 1, 2ºizqda Leioa
48940 Vizcaya Spain
Tel: (34) 944-805389
Fax: (34) 944-801550

Germany

Sumitomo (SHI) Cyclo Drive Germany, GmbH (SCG)
Cyclostraße 92
85229 Markt Indersdorf
Germany
Tel: (49) 8136-66-0
Fax: (49) 8136-5771

Austria

SCG Branch Austria Office
Grüntalerstraße 30A A4028 Linz,
Austria
Tel: (43) 732-330958
Fax: (43) 732-331978

China

Sumitomo (SHI) Cyclo Drive China, Ltd. (SCT)
Room 2606, Raffles City, No. 268,
Middle Kizang Road,
Shanghai 200001,
China
Tel: (86) 21-6340-4000
Fax: (86) 21-6340-3673

Hong Kong

SM-Cyclo of Hong Kong Co., Ltd. (SMHK)
Unit 1802, 18/F, Park Building,
476 Castle Peak Road, Kowloon,
Hong Kong
Tel: (852) 2460-1881
Fax: (852) 2460-1882

Singapore

Sumitomo (SHI) Cyclo Drive Asia Pacific Pte. Ltd. (SCA)
No.36 Tuas South Street 3,
Singapore 638031
Tel: (65) 6863-2238
Fax: (65) 6863-4238

Malaysia

SM-Cyclo (Malaysia) Sdn. Bhd. (SMMA)
No.2, Jalan BP 4/1,
Bandar Bukit Puchong, 47100 Puchong,
Selangor Darul Ehsan,
Malaysia
Tel: (60) 3-8061-2909
Fax: (60) 3-8061-3909

Thailand

SM-Cyclo (Thailand) Co., Ltd. (SMTH)
195, Empire Tower
Unit 1504, 15th Floor
South Sathorn Road,
Yannawa Sathorn Bangkok 10120,
Thailand
Tel: (66) 2-670-0998
Fax: (66) 2-670-0999

Vietnam

Sumitomo (SHI) Cyclo-Drive Asia Pacific Pte. Ltd.
Representative Office in Ho Chi Minh
Floor 4th, 99 Nguyen Thi Minh Khai Street
World Ben Thanh, District 1, HCM,
Vietnam
Tel: (84) 8-925-6504
Fax: (84) 8-925-6505

Australia

SM-Cyclo (Australia) Pty., Ltd. (SMAU)
9 Holbeche Rd,
Arndell Park, NSW, 2148,
Australia
Postal: PO Box 319 Doonside NSW, 2767
Tel: (61) 2-8811-6555
Fax: (61) 2-8811-6500
National Telephone Number: 1-3000 DRIVE

Philippines

Sumitomo (SHI) Cyclo Drive Asia Pacific Pte. Ltd.
Representative Office
Unit 23E Burgundy Corporate Tower
252 Sen. Gil Puyat Ave. Makati City,
Philippines
Tel: (63) 2-6800-6500
Fax: (63) 2-6800-6555

India

Sumi-Cyclo Drive India Private, Ltd. (SMIN)
Survey No. 130, Hissa No. 02, Jeevan Nagar
Next to T. V. S. Logistics,
Off Mumbai Bangalore By Pass,
Tathawade, Pune 411 033,
India
Tel: (91) 20-6674-2900
Fax: (91) 20-6674-2901

Taiwan

Tatung SM-Cyclo Co., Ltd. (TSC)
22 Chungshan N. Road
3rd., Sec. Taipei, Taiwan 104, R.O.C.
Tel: (886) 2-2595-7275
Fax: (886) 2-2595-5594

Korea

Sumitomo (SHI) Cyclo Drive Korea Ltd. (SCK)
Royal Bldg. 9F Rm. 913,
5 Danju-dong, Jongro-Gu,
Seoul, Korea 110-721
Tel: (82) 2-730-0151
Fax: (82) 2-730-0156

Japan

Sumitomo Heavy Industries, Ltd.
ThinkPark Tower, 1-1, Osaki 2-Chome
Shinagawa-ku, Tokyo 141-6025,
Japan
Tel: (81) 3-6737-2511
Fax: (81) 3-6866-5160

Sumitomo Drive Technologies

CYCLO[®] 6000 Series

Gearmotor & Speed Reducer

Sumitomo Drive Technologies
Always on the Move

CYCLO[®] 6000 Series
Gearmotor & Speed Reducer



Table of Contents

	Page
A. Common	A-1~12
Features & Benefits	A-3
Product Line-up	A-4
Product Range of CYCLO® DRIVE	A-6
Product Range of Motor	A-9
B. Gearmotors	B-1~154
1. How to Select	B-2
2. Selection Tables	B-13
3. Dimension Tables	B-97
C. Speed Reducers	C-1~88
1. How to Select	C-2
2. Selection Tables	C-11
3. Dimension Tables	C-69
D. Gearmotor for Inverters with AF Motor for Inverters	D-1~40
1. How to Select	D-2
2. Selection Tables	D-11
3. Dimension Tables	D-27
E. Gearmotors with High Efficiency Motor	E-1~6
F. Technical Data	F-1~68
1. Reducer	F-2
2. Motor	F-31
3. Common	F-63
Warranty Standard	G-1
Warning	G-2

Over 10 Million in the Making

Sumitomo Drive Technologies is a world-class leader in power transmission and control devices. Our top lined product, the Cyclo® Drive is actively serving industries throughout the world through its popular and unique epitrochoidal mechanism. The Cyclo® Drive has served over ten million units worldwide in a wide range of model offerings.

With the technical know-how and experience cultivated over 70 years, we provide complete satisfaction with unrivalled product reliability, durability and economy. This is achieved through our continual product R&D and state-of-the-art production facilities. Sumitomo Drive Technologies is Quality System Certified to ISO 9001, EN29001, BS5750 Part 1: 1987, JIS Z9901:1991 standard for design and manufacture of mechanical speed reducers, mechanical variators, electric motors and gearmotors in over 30 facilities located around the world.

The Sumitomo Drive Technologies' brand guarantees innovative, top quality products and services developed by the most advanced technologies. We strive to exceed the expectations of our customers, and continue to be your dependable partner in business.

High Shock Load, High Reliability Cycloidal Speed Reducers and Gearmotors

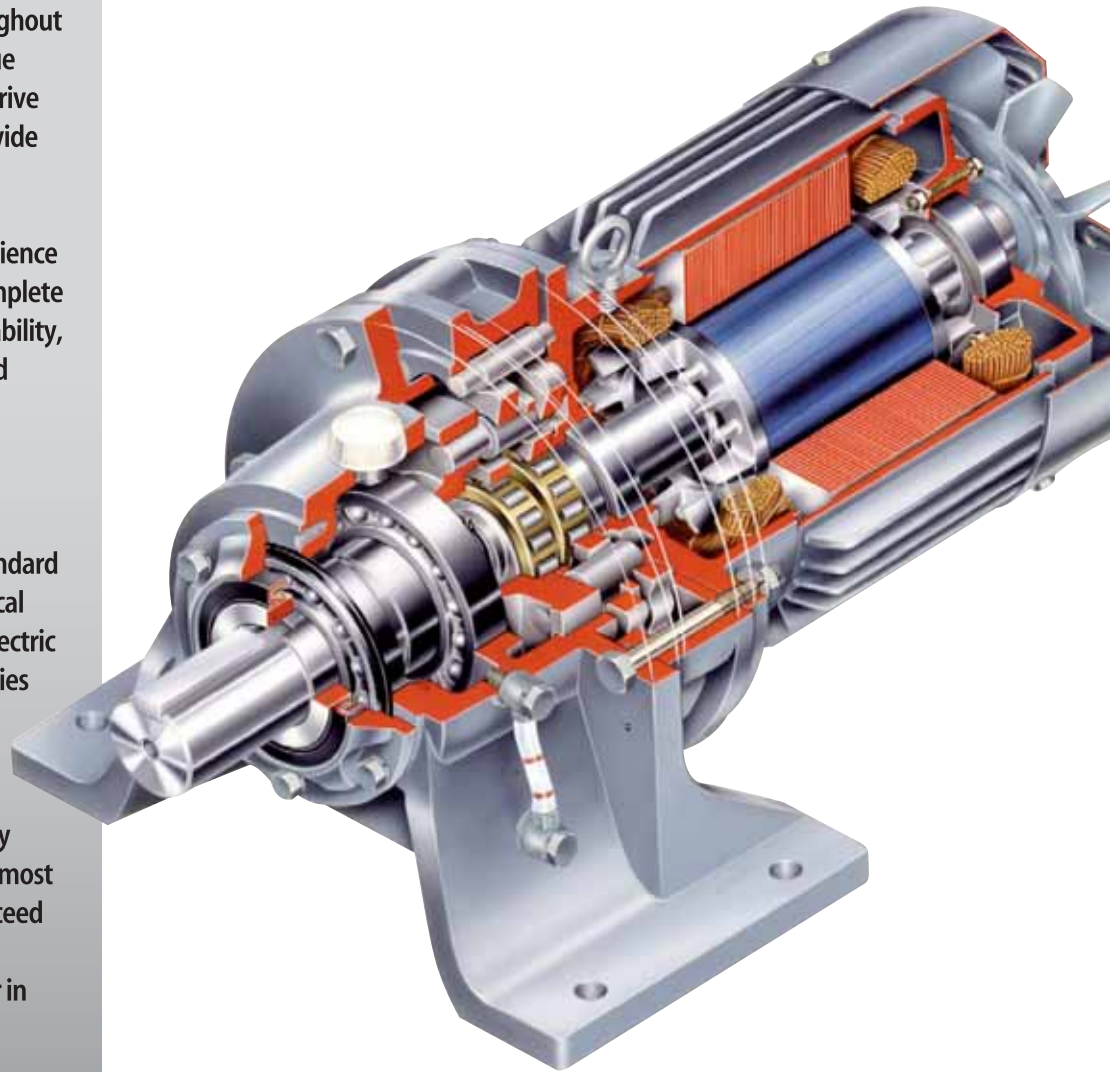

Exceptional Performance, Unmatched Reliability

The Sumitomo Cyclo® Drive is unsurpassed by any other inline drive available in the market today. Cyclo®'s unique cycloid design has advantages superior to speed reducers using common involute tooth gears. Unlike gear teeth with limited contact points, the Cyclo® has two-thirds of its reduction components in contact at all times. Cyclo® speed reducers and gearmotors are designed to withstand shock loads exceeding ratings of 500%, provide exceptional performance, reliability and long life in the most severe applications.



Features & Benefits

❖ Outstanding Reliability - 2 Year Warranty

Cyclo® Drive speed reducers and gearmotors provide customers with a typical operating life of 20 years. We back this assurance with a two year warranty on all Cyclo® products.

❖ Smooth Operation and Low Noise

In comparison to the sliding tooth contact of the conventional gearing, the rolling contact of the Cyclo® system provides a reduced noise level.

❖ Durable, Robust Construction

On top of the unique mechanism and design, Cyclo® housings are made of cast iron with the exception of our three smallest size models. All rotating elements are made from Chromium Molybdenum bearing steel, which have been hardened and ground.

❖ Selection and Variety

Reduction Ratios from 1/3 to 1/119 are available for the single stage; for triple stages we offer ratios up to 1,000,000:1.

Applications

Applications Include: Conveyors, Automotive Plants, Recycling Machines, Waterwaste Treatment, Steel Mills, Construction Equipment, Paper Mills, Food Machinery, Poultry Plants, Sawmills and Wood Mills, Processing Plants,



Clockwise from Top-Left: Chemical and Food Industry (agitator, mixer), Logistics and Handling Machines (sorting machines, conveyors), Iron and Steel Manufacturing (conveyors) and Water Treatment Machines (agitators).

❖ Superior Design, Powerful Performance ❖



CYCLO® SPEED REDUCER

All torque transmitting parts roll, not grind. The gear tooth profile of the Cyclo® reducer enables the sharing of the load by a number of teeth, thus not susceptible to tooth breakage.



CONVENTIONAL HELICAL REDUCER

Involute gears allow for small tooth engagement rate. Torque transmitting parts grind, wear, and can break off with the sliding contact.

CYCLO® 6000 Series

Product Line-up

sumitomo.bonnew.com

sales@sogears.com

6w

Commercial

Industrial

In-Line

ASTERO®

Practical and Convenient



ASTERO®

Modular system of motors and gearheads. Maximum flexibility and interchangeability.
Power: 6W~90W Ratio: 1/3~1/2000

Offset-Parallel

CYCLO®

Unmatched Reliability,
Exceptional Performance Cycloidal Drives



6000 Series

Unique Cycloidal gear teeth and mechanism is unsurpassed by any other inline drive. Simple and compact design.
Power: 0.1kW~132kW Ratio: 1/6~1/1,000,00

Right-Angle

HYPONIC DRIVE®

Quiet, Compact & Maintenance Free



HYPONIC

Highly efficient, grease lubricated, compact design hypoid gearing.
Power: 15W~90W Ratio: 1/5~1/1440



HYPONIC

Patented all-steel hypoid gear technology is extremely high-performance and more efficient than worm gearing.
Power: 90W~5.5kW Ratio: 1/5~1/1440



HBB Series

Integrated parallel shaft mount design, single stage, helical gearbox for durability.
Power: 0.1kW~132kW Ratio: 1/6~1/1,000,00



BBB Series

Incorporates the strength and flexibility of the Cyclo® reducer with adaptability of a shaft-mounted design in a right angle spiral bevel gearbox for exceptional reliability.
Power: 0.1kW~30kW Ratio: 1/11~1/10658

Motion Control Drives (MCD)

High Precision, Very Low Backlash



F Series CYCLO®
Rolling contact of cycloid discs, optimum load distribution, and low vibration yields highest efficiencies.

Torque: 111N·m ~ 5140N·m Ratio: 1/29~1/119
Backlash: No Backlash Lost Motion: 0.5~1.0arc min



IB Series P Type
Precision planetary gearheads for Servomotor applications in the most compact design.

Torque: 8.3N·m ~ 127N·m Ratio: 1/5~1/45
Backlash: 3~10min

Engineering

552kN•m

PARAMAX®High Quality & Maximum Efficiency,
Computer-Aided Design

9000 Series

The offset-parallel 9000 Series allow direct motor mounting and has universal housing for unique mounting positions.
Power:2.6~552kN•m Ratio:1/6.3~1/500



9000 Series

The new 9000 Series design combines helical gears and bevel gears in a right-angle gearbox for compact drive assembly.
Power:2.6~552kN•m Ratio:1/6.3~1/500

**LB Series CYCLO®**

The reputation of the Cyclo® Drive's strength to the Servomotor gives us a direct coupling gearhead possibility for a maintenance free operation.

Torque:30N•m~630Nm Ratio:1/11~1/29
Backlash:6min

Sumitomo Drives**Speed Variators****BEIER Variator**
BEIER CYCLO® Variator

Constant power torque converters with extremely accurate speed/ratio holding and repeatability to control speeds on industrial machinery.
Capacity 0.2kW~150kW

**Inverters**
SF320α•HF320α•HF430

Multiple functions, easy to use highly efficient Inverter.
Output Power:
0.1kW~55kW

Shaft-Mounted Speed Reducer**HSM**

Maximum loading and the highest efficiency torque output in the most compact design.
Power: 0.2kW~224kW

Worm Gears**HEDCON®**

Unique double contact theory, high efficiency, and high strength work reduction mechanism.
Power: 589~82,400N•m
Ratio:1/5~1/100

Planetary Gears**COMPOWER®**

Unique load sharing mechanism, high precision carburized ground gears.
Power:1.47~736kN•m
Ratio:1/5~1/1768

Product Line-up

Product Range of CYCLO® DRIVE

CYCLO® Frame Size

Table A-1 CYCLO Frame Size

6000SK Series Frame Size	6000 Series							
	Single Reduction				Double Reduction			
	Frame Size	Frame Size	(Output side + Input side)	Frame Size	(Output side + Input side)	Frame Size	(Output side + Input side)	
6060	6140	6060DA	(6060+6060)	6140DC	(6140+6105)	6190DA	(6190+6125)	
6075SK	6145	6065DA	(6065+6060)	6145DA	(6145+6075)	6190DB	(6190+6135)	
6080SK	614H	6070DA	(6070+6065)	6145DB	(6145+6095)	6195DA	(6195+6125)	
6085SK	6160	6075DA	(6075+6065)	6145DC	(6145+6105)	6195DB	(6195+6135)	
6090SK	6165	6090DA	(6090+6075)	6160DA	(6160+6095)	6205DA	(6205+6125)	
6095SK	616H	6095DA	(6095+6075)	6160DB	(6160+6105)	6205DB	(6205+6135)	
6100SK	6170	6100DA	(6100+6075)	6160DC	(6160+6125)	6215DA	(6215+6135)	
6105SK	6175	6105DA	(6105+6075)	6165DA	(6165+6095)	6215DB	(6215+6165)	
6110SK	6180	6120DA	(6120+6075)	6165DB	(6165+6105)	6225DA	(6225+6135)	
6115SK	6185	6120DB	(6120+6095)	6165DC	(6165+6125)	6225DB	(6225+6175)	
	6190	6125DA	(6125+6075)	6170DA	(6170+6095)	6235DA	(6235+6165)	
	6195	6125DB	(6125+6095)	6170DB	(6170+6105)	6235DB	(6235+6185)	
	6205	6130DA	(6130+6075)	6170DC	(6170+6125)	6245DA	(6245+6165)	
	6215	6130DB	(6130+6095)	6175DA	(6175+6095)	6245DB	(6245+6185)	
	6225	6130DC	(6130+6105)	6175DB	(6175+6105)	6255DA	(6255+6175)	
	6235	6135DA	(6135+6075)	6175DC	(6175+6125)	6255DB	(6255+6195)	
	6245	6135DB	(6135+6095)	6180DA	(6180+6105)	6265DA	(6265+6195)	
	6255	6135DC	(6135+6105)	6180DB	(6180+6135)	6275DA	(6275+6195)	
	6265	6140DA	(6140+6075)	6185DA	(6185+6105)			
	6275	6140DB	(6140+6095)	6185DB	(6185+6135)			

Reduction Ratio

Table A-2 6000 Series

Single Reduction								
6	8	11	13	15	17	21	25	29
35	43	51	59	71	87	119		

Double Reduction indicated in catalog (Upper row: reduction ratio, lower row: output side reduction ratio x input side reduction ratio)										
104	121	143	165	195	231	273	319	377	473	559
(13 × 8)	(11 × 11)	(13 × 11)	(15 × 11)	(15 × 13)	(21 × 11)	(21 × 13)	(29 × 11)	(29 × 13)	(43 × 11)	(43 × 13)
649	731	841	1003	1247	1479	1849	2065	2537	3045	3481
(59 × 11)	(43 × 17)	(29 × 29)	(59 × 17)	(43 × 29)	(87 × 17)	(43 × 43)	(59 × 35)	(59 × 43)	(87 × 35)	(59 × 59)
4437	5133 ^{Note1}	6177	7569							
(87 × 51)	(87 × 59)	(87 × 71)	(87 × 87)							

Note 1: Frame size 6205# ~ 6265# are (59 × 87)

Other Reduction Ratios (Under certain conditions, the following reduction ratios may also be available, please consult us.)

Reduction Ratio	88	90	102	120	126	136	150	168	169	174	187	200	210	221	225	232	255	258	275	
	(11 × 8)	(15 × 6)	(17 × 6)	(15 × 8)	(21 × 6)	(17 × 8)	(25 × 6)	(21 × 8)	(13 × 13)	(29 × 6)	(17 × 11)	(25 × 8)	(35 × 6)	(17 × 13)	(15 × 15)	(29 × 8)	(17 × 15)	(43 × 6)	(25 × 11)	
Output speed	16.5	16.1	14.2	12.1	11.5	10.7	9.67	8.63	8.58	8.33	7.75	7.25	6.90	6.56	6.44	6.25	5.69	5.62	5.27	
r/min	60Hz	19.9	19.4	17.2	14.6	13.9	12.9	11.7	10.4	10.4	10.1	9.36	8.75	8.33	7.92	7.78	7.54	6.86	6.87	6.36
Reduction Ratio	280	289	306	315	325	344	354	357	375	385	408	425	426	435	441	455	472	493	522	
	(35 × 8)	(17 × 17)	(51 × 6)	(21 × 15)	(25 × 13)	(43 × 8)	(59 × 6)	(21 × 17)	(25 × 15)	(35 × 11)	(51 × 8)	(25 × 17)	(71 × 6)	(29 × 15)	(21 × 21)	(35 × 13)	(59 × 8)	(29 × 17)	(87 × 6)	
Output speed	5.18	5.02	4.74	4.60	4.46	4.22	4.10	4.06	3.87	3.77	3.55	3.41	3.40	3.33	3.29	3.19	3.07	2.94	2.78	
r/min	60Hz	6.25	6.06	5.72	5.56	5.38	5.09	4.94	4.90	4.67	4.55	4.29	4.12	4.11	4.02	3.97	3.85	3.71	3.55	3.35
Reduction Ratio	525	561	568	595	609	625	645	663	696	725	735	765	767	781	867	875	885	903	923	
	(35 × 15)	(51 × 11)	(71 × 8)	(35 × 17)	(29 × 21)	(25 × 25)	(43 × 15)	(51 × 13)	(87 × 8)	(29 × 25)	(35 × 21)	(51 × 15)	(59 × 13)	(71 × 11)	(51 × 17)	(35 × 25)	(59 × 15)	(43 × 21)	(71 × 13)	
Output speed	2.76	2.58	2.55	2.44	2.38	2.32	2.25	2.19	2.08	2.00	1.97	1.90	1.89	1.86	1.67	1.66	1.64	1.61	1.57	
r/min	60Hz	3.33	3.12	3.08	2.94	2.87	2.80	2.71	2.64	2.51	2.41	2.38	2.29	2.28	2.24	2.02	2.00	1.98	1.94	1.90
Reduction Ratio	957	1015	1065	1071	1075	1131	1207	1225	1239	1275	1305	1475	1491	1505	1711	1775	1785	1827	2059	
	(87 × 11)	(35 × 29)	(71 × 15)	(51 × 21)	(43 × 25)	(87 × 13)	(71 × 17)	(35 × 35)	(59 × 21)	(51 × 25)	(87 × 15)	(59 × 25)	(71 × 21)	(43 × 35)	(59 × 29)	(71 × 25)	(51 × 35)	(87 × 21)	(71 × 29)	
Output speed	1.52	1.43	1.36	1.35	1.35	1.28	1.20	1.18	1.17	1.14	1.11	0.98	0.97	0.96	0.85	0.82	0.81	0.79	0.70	
r/min	60Hz	1.83	1.72	1.64	1.63	1.63	1.55	1.45	1.43	1.41	1.37	1.34	1.19	1.17	1.16	1.02	0.99	0.98	0.96	0.85
Reduction Ratio	2175	2193	2485	2523	2601	3009	3053	3621	3741	4189	5041	Calculation of output speed is based on the following input speed.								
	(87 × 25)	(51 × 43)	(71 × 35)	(87 × 29)	(51 × 51)	(59 × 51)	(71 × 43)	(71 × 41)	(87 × 43)	(71 × 59)	(71 × 71)									
Output speed	0.67	0.66	0.58	0.57	0.56	0.48	0.47	0.40	0.39	0.45	0.29	50Hz: 1450r/min								
r/min	60Hz	0.80	0.80	0.70	0.69	0.67	0.58	0.57	0.48	0.47	0.42	60Hz: 1750r/min								

Table A-3 6000SK Series (Actual Reduction Ratio)

Frame Size	Nominal Reduction Ratio						
	2.5	3	4	5	6	8	10
6070SK, 6075SK	2.514	2.911	3.985	5.109	5.915	8.097	9.848
6080SK, 6085SK	2.475	2.931	3.878	5.114	6.164	7.660	9.474
6090SK, 6095SK	2.492	2.878	4.100	5.017	5.623	8.169	9.996
6100SK, 6105SK	2.492	2.878	4.100	5.017	5.623	8.169	9.996
6110SK, 6115SK	2.483	3.063	3.859	4.707	5.980	7.738	10.07

*Note that reduction ratio differs for each frame size for 6000SK Series.

Product Range of CYCLO® DRIVE

Available Combination

Table A-4 6000SK Series

Nominal Reduction Ratio		2.5	3	4	5	6	8	10
Output Speed	50Hz	580	483	363	290	242	181	145
	r/min	700	583	438	350	292	219	175
0.4 × 4P	kW	●	●	●	●	●	●	●
0.55 × 4P	kW	●	●	●	●	●	●	●
0.75 × 4P	kW	●	●	●	●	●	●	●
1.1 × 4P	kW	●	●	●	●	●	●	●
1.5 × 4P	kW	●	●	●	●	●	●	●
2.2 × 4P	kW	●	●	●	●	●	●	●
3.0 × 4P	kW	●	●	●	●	●	●	●
3.7 × 4P	kW	●	●	●	●	●	●	●
5.5 × 4P	kW	●	●	●	●	●	●	●

Table A-5 6000 Series Single Reduction

Reduction Ratio	6	8	11	13	15	17	21	25	29	35	43	51	59	71	87	119
Output Speed	50Hz	242	181	132	112	96.7	85.3	69	58	50	41.4	33.7	28.4	24.6	20.4	16.7
	r/min	292	219	159	135	117	103	83.3	70	60.3	50	40.7	34.3	29.7	24.6	20.1
0.1 × 4P	kW	●	●	●	●	●	●	●	●	●	●	●	●	●	●	●
0.2 × 4P	kW	●	●	●	●	●	●	●	●	●	●	●	●	●	●	●
0.25 × 4P	kW	●	●	●	●	●	●	●	●	●	●	●	●	●	●	●
0.4 × 4P	kW	●	●	●	●	●	●	●	●	●	●	●	●	●	●	●
0.55 × 4P	kW	●	●	●	●	●	●	●	●	●	●	●	●	●	●	●
0.75 × 4P	kW	●	●	●	●	●	●	●	●	●	●	●	●	●	●	●
1.1 × 4P	kW	●	●	●	●	●	●	●	●	●	●	●	●	●	●	●
1.5 × 4P	kW	●	●	●	●	●	●	●	●	●	●	●	●	●	●	●
2.2 × 4P	kW	●	●	●	●	●	●	●	●	●	●	●	●	●	●	●
3.0 × 4P	kW	●	●	●	●	●	●	●	●	●	●	●	●	●	●	●
3.7 × 4P	kW	●	●	●	●	●	●	●	●	●	●	●	●	●	●	●
5.5 × 4P	kW	●	●	●	●	●	●	●	●	●	●	●	●	●	●	●
7.5 × 4P	kW	●	●	●	●	●	●	●	●	●	●	●	●	●	●	●
11 × 4P	kW	●	●	●	●	●	●	●	●	●	●	●	●	●	●	●
15 × 4P	kW	●	●	●	●	●	●	●	●	●	●	●	●	●	●	●
18.5 × 4P	kW	●	●	●	●	●	●	●	●	●	●	●	●	●	●	●
22 × 4P	kW	●	●	●	●	●	●	●	●	●	●	●	●	●	●	●
30 × 4P	kW	●	●	●	●	●	●	●	●	●	●	●	●	●	●	●
37 × 4P	kW		●	●	●	●	●	●	●	●	●	●	●	●	●	●
45 × 4P	kW		●	●	●	●	●	●	●	●	●	●	●	●	●	●
55 × 4P	kW		●	●	●	●	●	●	●	●	●	●	●	●	●	●
75 × 4P	kW		●	●	●	●	●	●	●	●	●	●	●	●	●	●

Reduction Ratio	11	15	21	29	43	59	87
Output Speed	50Hz	89.1	65.3	46.7	33.8	22.8	16.6
	r/min	106	77.7	55.5	40.2	27.1	19.7
15 × 6P	kW					●	●
18.5 × 6P	kW				●	●	●
22 × 6P	kW				●	●	●
30 × 6P	kW		●	●	●	●	●
37 × 6P	kW		●	●	●	●	●
45 × 6P	kW		●	●	●	●	●
55 × 6P	kW	●	●	●	●	●	●
75 × 6P	kW	●	●	●	●	●	●
90 × 6P	kW	●	●	●	●	●	●
110 × 6P	kW	●	●	●	●	●	●
132 × 6P	kW	●	●	●	●	●	●

- Note: 1. Calculation of output speed is based on the following input speed.
- 4P Motor
 - 50Hz: 1450 r/min
 - 60Hz: 1750 r/min
 - 6P Motor
 - 50Hz: 980 r/min
 - 60Hz: 1165 r/min
2. Combination in the table is based on service factor 1.0. Refer to Gearmotor Selection Table for combinations with other service factors.
3. Reduction ratios in 6000SK Series table are nominal ratios. Output speeds are based on these ratios. Refer to "Reduction Ratio" tables in the previous page for actual reduction ratio.
4. The rated current of 6P motor is different from the one of 4P motor even if the power is same.

COMMON

Product Range of CYCLO® DRIVE

Table A-6 6000 Series Double Reduction

COMMON

Reduction Ratio	104	121	143	165	195	231	273	319	377	473	559	649	731	841	1003	1247	1479	1849	2065	
Output Speed 50Hz	13.9	12.0	10.1	8.79	7.44	6.28	5.31	4.55	3.85	3.07	2.59	2.23	1.98	1.72	1.45	1.16	0.980	0.784	0.702	
r/min 60Hz	16.8	14.5	12.2	10.6	8.97	7.58	6.41	5.49	4.64	3.70	3.13	2.70	2.39	2.08	1.74	1.40	1.18	0.946	0.847	
0.1 × 4P kW	●	●	●	●	●	●	●	●	●	●	●	●	●	●	●	●	●	●	●	●
0.2 × 4P kW	●	●	●	●	●	●	●	●	●	●	●	●	●	●	●	●	●	●	●	●
0.25 × 4P kW	●	●	●	●	●	●	●	●	●	●	●	●	●	●	●	●	●	●	●	●
0.4 × 4P kW	●	●	●	●	●	●	●	●	●	●	●	●	●	●	●	●	●	●	●	●
0.55 × 4P kW	●	●	●	●	●	●	●	●	●	●	●	●	●	●	●	●	●	●	●	●
0.75 × 4P kW	●	●	●	●	●	●	●	●	●	●	●	●	●	●	●	●	●	●	●	●
1.1 × 4P kW	●	●	●	●	●	●	●	●	●	●	●	●	●	●	●	●	●	●	●	●
1.5 × 4P kW	●	●	●	●	●	●	●	●	●	●	●	●	●	●	●	●	●	●	●	●
2.2 × 4P kW	●	●	●	●	●	●	●	●	●	●	●	●	●	●	●	●	●	●	●	●
3.0 × 4P kW	●	●	●	●	●	●	●	●	●	●	●	●	●	●	●	●	●	●	●	●
3.7 × 4P kW	●	●	●	●	●	●	●	●	●	●	●	●	●	●	●	●	●	●	●	●
5.5 × 4P kW	●	●	●	●	●	●	●	●	●	●	●	●	●	●	●	●	●	●	●	●
7.5 × 4P kW	●	●	●	●	●	●	●	●	●	●	●	●	●	●	●	●	●	●	●	●
11 × 4P kW	●	●	●	●	●	●	●	●	●	●	●	●	●	●	●	●	●	●	●	●
15 × 4P kW	●	●		●	●	●	●	●	●	●	●	●	●	●	●					
18.5 × 4P kW		●		●	●	●	●	●	●	●	●	●	●	●						
22 × 4P kW		●		●	●	●	●	●	●	●	●	●	●							
30 × 4P kW		●		●	●	●	●	●	●	●										
37 × 4P kW		●		●	●	●		●	●											
45 × 4P kW		●		●	●			●												

Reduction Ratio	2537	3045	3481	4437	5133	6177	7569
Output Speed 50Hz	0.572	0.476	0.417	0.327	0.282	0.235	0.192
r/min 60Hz	0.690	0.575	0.503	0.394	0.341	0.283	0.231
0.1 × 4P kW	●	●	●	●	●	●	●
0.2 × 4P kW	●	●	●	●	●	●	●
0.25 × 4P kW	●	●					
0.4 × 4P kW	●	●	●	●	●	●	●
0.75 × 4P kW	●	●	●	●	●	●	●
1.5 × 4P kW	●	●	●	●	●	●	●
2.2 × 4P kW	●	●	●	●	●	●	●
3.7 × 4P kW	●	●	●	●	●	●	●
5.5 × 4P kW	●	●	●	●	●	●	●

Note: 1. Calculation of output speed is based on the following input speed.

- 4P Motor
 - 50Hz: 1450 r/min
 - 60Hz: 1750 r/min
- 6P Motor
 - 50Hz: 980 r/min
 - 60Hz: 1165 r/min

2. Combination in the table is based on service factor 1.0. Refer to Gearmotor Selection Table for combinations with other service factors.
3. Reduction ratios in 6000SK Series table are nominal ratios. Output speeds are based on these ratios. Refer to "Reduction Ratio" tables in the previous page for actual reduction ratio.
4. The rated current of 6P motor is different from the one of 4P motor even if the power is same.

Product Range of Motor

Table A-7 3-Phase Induction Motors

◎: Standard Thermal Class ○: Manufactured Models

Specification		Indoor or Outdoor (IP55)				Corrosion Proof Class 2		Thermal Class								Inverter Motors (Constant Torque)												
Capacity (kW)	P	4		6		4		6		E		B		F		H		Indoor Type		Outdoor Type								
		4	6	4	6	4	6	4	6	4	6	4	6	4	6	4	6	4	6	4	6							
0.1		○	○	○	○	○	○	○	○	○	○	◎	◎	○	○	○	○	○	○	○	○							
0.2		○	○	○	○	○	○	○	○	○	○	◎	◎	○	○	○	○	○	○	○	○							
0.25		○	○	○	○	○	○	○	○	○	○	◎	◎	○	○	○	○	○	○	○	○							
0.4		○	○	○	○	○	○	○	○	○	○	◎	◎	○	○	○	○	○	○	○	○							
0.55		○	○	○	○	○	○	○	○	○	○	◎	◎	○	○	○	○	○	○	○	○							
0.75		○	○	○	○	○	○	○	○	○	○	◎	◎	○	○	○	○	○	○	○	○							
1.1		○	○	○	○	○	○	○	○	○	○	◎	◎	○	○	○	○	○	○	○	○							
1.5		○	○	○	○	○	○	○	○	○	○	◎	◎	○	○	○	○	○	○	○	○							
2.2		○	○	○	○	○	○	○	○	○	○	◎	◎	○	○	○	○	○	○	○	○							
3.0		○	○	○	○	○	○	○	○	○	○	◎	◎	○	○	○	○	○	○	○	○							
3.7		○	○	○	○	○	○	○	○	○	○	◎	◎	○	○	○	○	○	○	○	○							
5.5		○	○	○	○	○	○	○	○	○	○	◎	◎	○	○	○	○	○	○	○	○							
7.5		○	○	○	○	○	○	○	○	○	○	◎	◎	○	○	○	○	○	○	○	○							
11		○	○	○	○	○	○	○	○	○	○	◎	◎	○	○	○	○	○	○	○	○							
15		○	○	○	○	○	○	○	○	○	○	◎	◎	○	○	○	○	○	○	○	○							
18.5		○	○	○	○	○	○	○	○	○	○	◎	◎	○	○	○	○	○	○	○	○							
22		○	○	○	○	○	○	○	○	○	○	◎	◎	○	○	○	○	○	○	○	○							
30		○	○	○	○	○	○	○	○	○	○	◎	◎	○	○	○	○	○	○	○	○							
37		○	○	○	○	○	○	○	○	○	○	◎	◎	○	○	○	○	○	○	○	○							
45		○	○	○	○	○	○	○	○	○	○	◎	◎	○	○	○	○	○	○	○	○							
55		○	○	○	○	○	○	○	○	○	○	◎	◎	○	○	○	○	○	○	○	○							
Remarks	Continuous Rating		Applicable Voltage:		4P: 3.7kW and below		220 - 240V 50Hz		220V 60Hz		380 - 420V 50Hz		5.5kW and above		380 - 420V 50Hz		440 - 480V 60Hz		6P: 200V 50/60Hz		220V 60Hz		400V 50/60Hz		440V 60Hz			
	Provided that the base frequency for driving an inverter is 60Hz.																											

COMMON

Table A-8 3-Phase Induction Motors with Built-in Brakes ◎: Standard Thermal Class ○: Manufactured Models

Specification		Indoor or Outdoor (IP55)				Corrosion Proof Class 2		Insulation Class								Inverter Motors (Constant Torque)														
Capacity (kW)	P	4		6		4		6		E		B		F		H		Indoor Type		Outdoor Type										
		4	6	4	6	4	6	4	6	4	6	4	6	4	6	4	6	4	6	4	6									
0.1		○	○	○	○	○	○	◎	◎	○	○	○	○	○	○	○	○	○	○	○	○									
0.2		○	○	○	○	○	○	◎	◎	○	○	○	○	○	○	○	○	○	○	○	○									
0.25		○	○	○	○	○	○	◎	◎	○	○	○	○	○	○	○	○	○	○	○	○									
0.4		○	○	○	○	○	○	◎	◎	○	○	○	○	○	○	○	○	○	○	○	○									
0.55		○	○	○	○	○	○	◎	◎	○	○	○	○	○	○	○	○	○	○	○	○									
0.75		○	○	○	○	○	○	◎	◎	○	○	○	○	○	○	○	○	○	○	○	○									
1.1		○	○	○	○	○	○	◎	◎	○	○	○	○	○	○	○	○	○	○	○	○									
1.5		○	○	○	○	○	○	◎	◎	○	○	○	○	○	○	○	○	○	○	○	○									
2.2		○	○	○	○	○	○	◎	◎	○	○	○	○	○	○	○	○	○	○	○	○									
3.0		○	○	○	○	○	○	◎	◎	○	○	○	○	○	○	○	○	○	○	○	○									
3.7		○	○	○	○	○	○	◎	◎	○	○	○	○	○	○	○	○	○	○	○	○									
5.5		○	○	○	○	○	○	◎	◎	○	○	○	○	○	○	○	○	○	○	○	○									
7.5		○	○	○	○	○	○	◎	◎	○	○	○	○	○	○	○	○	○	○	○	○									
11		○	○	○	○	○	○	◎	◎	○	○	○	○	○	○	○	○	○	○	○	○									
15		○	○	○	○	○	○	◎	◎	○	○	○	○	○	○	○	○	○	○	○	○									
18.5		○	○	○	○	○	○	◎	◎	○	○	○	○	○	○	○	○	○	○	○	○									
22		○	○	○	○	○	○	◎	◎	○	○	○	○	○	○	○	○	○	○	○	○									
30		○	○	○	○	○	○	◎	◎	○	○	○	○	○	○	○	○	○	○	○	○									
37		○	○	○	○	○	○	◎	◎	○	○	○	○	○	○	○	○	○	○	○	○									
Remarks	Continuous Rating		Applicable Voltage:		4P: 3.7kW and below		220 - 240V 50Hz		220V 60Hz		380 - 420V 50Hz		5.5kW and above		380 - 420V 50Hz		400V 60Hz		6P: 200V 50/60Hz		220V 60Hz		400V 50/60Hz		440V 60Hz					
	Brake Thermal Class: F		Provided that the base frequency for driving an inverter is 60Hz.																											

- Note: 1. Motors with capacities and specifications other than as listed in Tables A-7 ~ A-10 are also manufactured. Consult factory.
 Examples : Special voltage, dust-proof, humidity proof, tropical treatment, high temperature, ship use, dual shaft (round & square shaft), CSA Standard, NEMA Standard, etc. For other corresponding Standards, refer to Comparison of Sumitomo Standards with International Standards on Page F52 ~ 56 of Technical Information.
2. Indicate outdoor type when placing 6P motor outdoor. Structure differs for indoor and outdoor type although protection type is IP44.
3. For inverter drive use, consult us with ambient temperature, input speed, mounting method, load characteristics, and other operation conditions. Startup properties, lubrication, thermal rating, and such must be reviewed for selection of proper CYCLO DRIVE frame size for combination.
4. For standard electric motor use with inverter, consult us if input voltage is high (400V or more), carrier frequency is high (typical in IGBT), or wiring distance is large. Review of withstand voltage of the motor may be necessary.

Product Range of Motor

Table A-9 Increased Safety (eG3) 3-Phase Induction Motor

⊙: Standard Insulation ○: Manufactured Models

Specification		Indoor Type (IP44)		Outdoor Type (IP44)		Corrosion Proof Class 2		Thermal Class			
Capacity (kW)	P	4	6	4	6	4	6	B		F	
								4	6	4	6
0.1		○		○		○		⊙		○	
0.2		○		○		○		⊙		○	
0.4		○		○		○		⊙		○	
0.75		○		○		○		⊙		○	
1.5		○		○		○		⊙		○	
2.2		○		○		○		⊙		○	
3.7		○		○		○		⊙		○	
5.5		○		○		○		⊙		○	
7.5		○	○	○	○	○	○	⊙	⊙	○	
11		○	○	○	○	○	○	⊙	⊙	○	
15		○	○	○	○	○	○	⊙	⊙		
18.5		○	○	○	○	○	○	⊙			⊙
22		○	○	○	○	○	○	⊙			⊙
30		○	○	○	○	○	○	⊙			⊙
37		○	○	○	○	○	○			○	⊙
45		○	○	○	○	○	○			○	⊙
55		○	○	○	○	○	○			○	⊙
Remarks	Continuous Rating Applicable Voltage : 200V, 220V, 350V, 380V, 400V, 440V, 50/60Hz										

COMMON

Table A-10 Flame-Proof (d2G4) 3-Phase Motor

⊙: Standard Insulation ○: Manufactured Models

Specification		Indoor Type (IP44)		Outdoor Type (IP44)		Corrosion Proof Class 1, 2		Thermal Class				Inverter Motors (Constant Torque)	
Capacity (kW)	P	4	6	4	6	4	6	B		F		Indoor Type	Outdoor Type
								4	6	4	6	4	6
0.1		○		○		○		⊙		○			
0.2		○		○		○		⊙		○		○	
0.4		○		○		○		⊙		○		○	
0.75		○		○		○		⊙		○		○	
1.5		○		○		○		⊙		○		○	
2.2		○		○		○		⊙		○		○	
3.7		○		○		○		⊙		○		○	
5.5		○		○		○		⊙		○		○	
7.5		○		○		○		⊙		○		○	
11		○		○		○		⊙		○		○	
15		○	○	○	○	○	○	⊙	○	○		○	○
18.5		○	○	○	○	○	○	⊙	⊙	○	○	○	○
22		○	○	○	○	○	○	⊙	⊙	○	○	○	○
30		○	○	○	○	○	○	⊙	⊙	○	○	○	○
37		○	○	○	○	○	○		⊙	⊙	○	○	○
Remarks	Continuous Rating Applicable Voltage : 200V, 220V, 350V, 380V, 400V, 440V, 50/60Hz (For inverter drive) Applicable inverter : 200V 60Hz 220V 60Hz 400V 60Hz 440V 60Hz Applicable only to Sumitomo inverters. (Refer to Inverter catalogue.)												

⚠ Safety Precautions

- Authorized combination in Japan for motor and inverter is 1:1 when explosion protection motor is driven with inverter. Always operate with the specific indicated inverter. Always locate inverter unit in the area without explosive gas; it does not have explosion protection structure.
- Consult us when the unit is exposed to the elements or to frequent water splashing.

M E M O

COMMON

M E M O

COMMON

A large grid of graph paper for taking notes, consisting of approximately 25 columns and 40 rows of small squares.

B

GEARMOTORS

CYCLO® GEARMOTORS

	Page
1. How to Select	
Standard Specifications	B-3
Model Selection	B-4
Selection of Load Factor	B-7
Nomenclature	B-9
2. Selection Tables	B-13
3. Dimension Tables	B-97

B CYCLO® GEARMOTORS

1. How to Select

Standard Specifications of Gearmotor

Motor

Items	Standard Specification		Standard Specification with Built-in Brake		
Capacity Range	0.1 - 55kW × 4P 15 - 55kW × 6P		0.1 - 11kW × 4P FB Brake (Non-Asbestors) 15kW × 4P CMB Brake 18.5 - 37kW × 4P ESB Brake *For 6P motor with brake, consult us.		
Enclosure	Totally enclosed fan cooled type (0.1kW × 4P totally enclosed non-ventilated)		Totally enclosed fan cooled type (0.1kW × 4P totally enclosed non-ventilated)		
Power Source	0.1 - 3.7kW:	220 - 240V 220V	50Hz 60Hz	0.1 - 3.7kW: 220 - 240V 220V 50Hz 60Hz	
	5.5 - 55kW:	380 - 420V 440V	50Hz 60Hz	5.5 - 37kW: 380 - 420V 440V 50Hz 60Hz	
Thermal Class	F		F		
Time Rating	Continuous rating		Continuous rating		
Terminal Box Position & Lead Wire Direction	On the left side viewed from the load side. Regarding the draw out hole direction, refer to Table below.		On the left side viewed from the load side. Regarding the draw out hole direction, refer to Table below.		
Lead Wiring	6 Wires	4P	6P	8 Wires	4P
		0.1~3.7kW (Direct starting) Note: 2 5.5~55kW (λ - Δ starting available)	- Note: 2 15~55kW (λ - Δ starting available)		0.1~3.7kW (Direct starting) Note: 2 5.5~37kW (λ - Δ starting available)
Standards	According to IEC				

GEARMOTORS
How to Select

Reducer

Items	Specifications	
Model	CYCLO 6000 Series	CYCLO 6000SK Series
Lubrication Method	Grease lubricated and oil lubricated models available	
Speed Reduction Method	Internal planetary gear mechanism with trochoidal curved tooth profile	
Direction of Output Shaft Rotation	Single reduction	Clockwise rotation
	Double reduction	Counter-clockwise rotation
	*Note that it is different from CYCLO 6000 series single reduction type	
	As observed from the load side when connected to R-U, S-V, T-W motors.	

Common to Motor and Reducer

Items	Specifications	
Ambient Conditions	Installation location	Indoor or outdoor (Minimal dust and humidity)
	Ambient Temperature	-10°C ~ 40°C
	Ambient Humidity	Under 85%
	Elevation	Under 1,000 meters above sea level
	Atmosphere	Well ventilated location, free of corrosive gases, explosive gases, vapors and dust.
Method of Mounting <small>Note: 3</small>	CHHM Type: slow speed shaft in horizontal direction and with foot CHFM Type: slow speed shaft in horizontal direction and with flange (not for 6000SK Series) CVVM Type: slow speed shaft down in vertical direction and with V-flange *Models with "N" for the second nomenclature symbol (such as CNHM Type) may be mounted in any direction.	
Method of Coupling with Driven Machine	Coupling, gears, chain sprocket or belt.	
Painting	Type: Acrylic modified phtalic Color: Equivalent to Munsell 6.5PB 3.6/8.2.	

- Note: 1. Refer to the technical section (Page F-31~57) for motor specification other than standard one.
 2. Consult us when λ - Δ start is necessary for non-standard voltage.
 3. Models for universal mounting (types with N for the second digit of nomenclature) can be manufactured for following frame sizes only. Other frame sizes require indication for mounting direction.

[Frame sizes for universal mounting direction] *□ of the frame size indicates 0, 5, or H.
 606□, 607□, 608□, 609□, 610□, 611□, 612□,
 606□DA, 607□DA, 608□DA, 609□DA, 610□DA, 612□DA, 612□DB

Direction of Withdrawing Lead Wire

Main frame mounting direction	Standard
Horizontal Type (Slow speed shaft in horizontal direction)	
Vertical Type (Slow speed shaft in vertical direction)	

Note: Whenever not specified, the above direction shall be used. When the direction of withdrawal from the terminal box is other than specified above, refer to Page F-34.

Model Selection

Select models referring to the following flowchart. Consult us if there is any question.
Step 1: Determination of Operating Condition

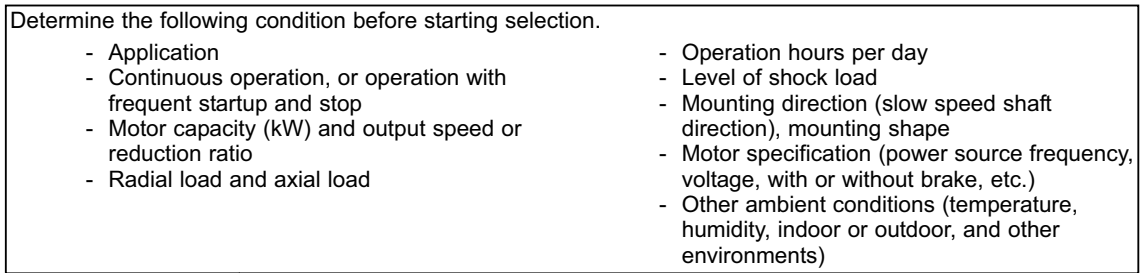

* Refer to section "D. CYCLO® GEARMOTORS (WITH AF MOTOR FOR INVERTERS)" for gearmotors with inverter motors.

Step 2: Model Selection

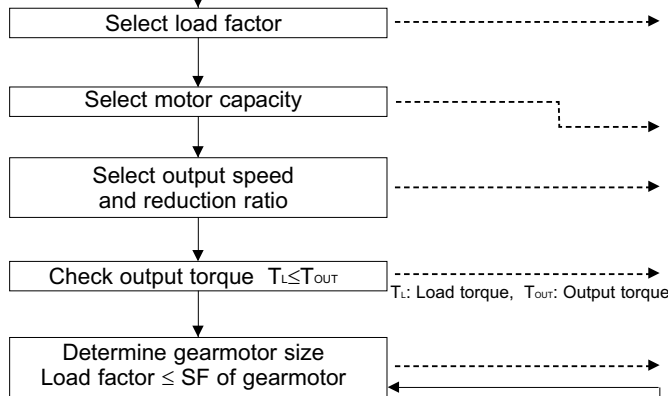

Procedure	
- Select appropriate load factor from page B-7~8. Check allowable thermal capacity for motor in page B-9 if startup and stop is repeated during operation.	<p>- Open the page with selection table for your motor capacity, starting from page B-13.</p> <p>- Select the cell containing close value to your output speed or reduction ratio in the selection table.</p> <p>- Check whether the output torque is sufficient for your usage. Raise motor capacity by one frame size if the output torque is not sufficient.</p> <p>- Select combination with service factor (SF), which is larger than the load factor, from the selection table.</p> <p>- Check whether only the radial load is applied on slow speed shaft. Refer to Technical Data starting at page F-10 and calculate if axial load is also applied.</p> <p>- Refer to Technical Data starting at page F-10 depending on where the radial load is applied, or if any shock load is applied or not.</p> <p>- *1 Allowable radial load for slow speed shaft in the selection table is when the load position is at the midpoint of the shaft.</p> <p>- *2 Calculate radial load including initial tension if they are applied using chain, V-belt, synchronous belt, etc.</p> <p>- Check whether the calculated radial load does not exceed allowable radial load of the slow speed shaft.</p> <p>- Check whether the selected combination is sufficient for your slow speed shaft direction, mounting style, and lubrication method.</p> <p>- Check whether the dimension is adequate. Consult us if it does not match your operation condition.</p> <p>- Check whether the selected combination is sufficient for your operation condition, such as surrounding environment. Refer to "Standard Specifications of Gearmotor" in page B-3 or section "F. Technical Data" for checking.</p> <p>- Check whether the selected motor is sufficient for your operation condition (power source, environment, thermal class, etc.).</p> <p>- Determine nomenclature for selected model referring to "Nomenclature" in page B-10. Now, the selection process is complete.</p>
- Check whether the output torque is sufficient for your usage. Raise motor capacity by one frame size if the output torque is not sufficient.	
- Select combination with service factor (SF), which is larger than the load factor, from the selection table.	
- Check whether only the radial load is applied on slow speed shaft. Refer to Technical Data starting at page F-10 and calculate if axial load is also applied.	
- Refer to Technical Data starting at page F-10 depending on where the radial load is applied, or if any shock load is applied or not.	
- *1 Allowable radial load for slow speed shaft in the selection table is when the load position is at the midpoint of the shaft.	
- *2 Calculate radial load including initial tension if they are applied using chain, V-belt, synchronous belt, etc.	
- Check whether the calculated radial load does not exceed allowable radial load of the slow speed shaft.	
- Check whether the selected combination is sufficient for your slow speed shaft direction, mounting style, and lubrication method.	
- Check whether the dimension is adequate. Consult us if it does not match your operation condition.	

Step 3: Check

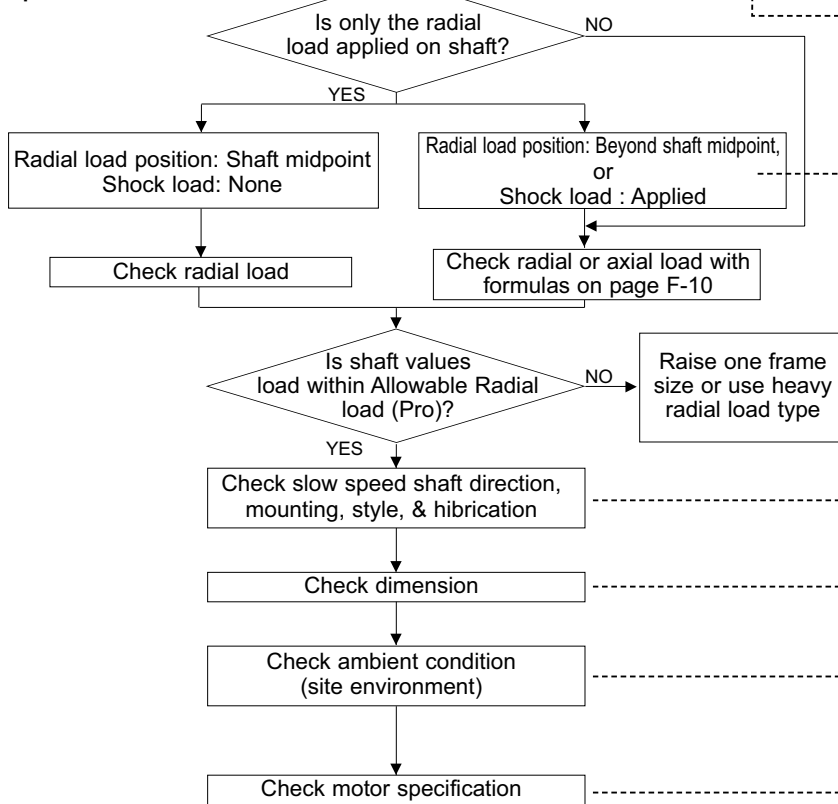

Step 4: Nomenclature Determination, Selection Complete

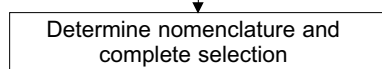

Model Selection

Description of Our Selection Table

This is a brief description of our tables on page B-13 and after.

Motor capacity (kW)

Input speed (r/min) (Indicated for each motor frequency and number of poles.)

7.5 kW		Hz				n: Motor Speed					
		50Hz		60Hz		50Hz		60Hz			
P		4	6	4	6						
n ₁		r/min		r/min		r/min		r/min			
		1450		980		1750		1165			

50Hz					60Hz					Nomenclature				
Output Speed n ₂ r/min	Output Torque Tout		Allowable Radial Load Pro		SF	Output Speed n ₂ r/min	Output Torque Tout		Allowable Radial Load Pro		Input Capacity Symbol	Frame Size	Reduction Ratio	
	N-m	kgf-m	N	kgf			N-m	kgf-m	N	kgf				
242	282	28.7	5980	610	1.25	292	233	23.8	5650	576	1.25	10	6130	- 6
			5980	610	1.51				5650	576	1.51	10	6135	- 6
			9330	951	1.73				8830	901	1.73	10	6140	- 6
			9330	951	2.01				8830	901	2.01	10	6145	- 6
			10400	1070	2.71				9830	1000	2.71	10	6160	- 6
181	375	38.3	6650	678	1.25	219	311	31.7	6290	641	1.25	10	6130	- 8
			6650	678	1.51				6290	641	1.51	10	6135	- 8
			10300	1050	1.73				9790	998	1.73	10	6140	- 8
			10300	1050	2.01				9790	998	2.01	10	6145	- 8
			11700	1190	2.63				11000	1120	2.63	10	6160	- 8
132	516	52.6	7570	771	1.25	159	428	43.6	7150	729	1.25	10	6130	- 11
			7570	771	1.51				7150	729	1.51	10	6135	- 11
			11600	1180	1.73				11000	1120	1.73	10	6140	- 11
			11600	1180	2.01				11000	1120	2.01	10	6145	- 11
			13200	1350	2.63				12500	1270	2.63	10	6160	- 11
			7860	801	1.25					1.25	10	6130	- 13	
			7860	801	1.36					1.51	10	6135	- 13	

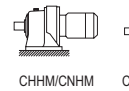

Output speed (r/min)

Service factor

[Input capacity symbol] - [Frame size] - [Reduction ratio]

*Note that "reduction ratio = normal ratio" for models with "SK" at the end of frame size (6000 SK Series with "3" on the side of reduction ratio). (Indicated reduction ratio is the same as actual reduction ratios for other models.)

GEARMOTORS
How to Select

Selection Example

Below is an example selection process following the model selection procedure in page B-4.

<ul style="list-style-type: none"> • Operation condition <ul style="list-style-type: none"> - Application: Chain conveyer - Operation hours per day: 24 hours/day - Operation pattern: Continuous operation - Load capacity: 0.7kW - Output speed: 33.7r/min - Connection with application: <ul style="list-style-type: none"> Chain sprocket Initial tension = 0 Sprocket pitch circle radius: R=61mm Load position: Midpoint of shaft - Level of shock load: None - Mounting direction (slow speed shaft direction), and mounting style: <ul style="list-style-type: none"> horizontal, foot mount 	<ul style="list-style-type: none"> - Motor specification <ul style="list-style-type: none"> Electric frequency: 50Hz Voltage: 200V Brake: None Others: Indoor type - Surrounding condition <ul style="list-style-type: none"> Ambient temperature 20°C for indoor use
---	--



The model is selected based on above operation conditions in this example.

Operation condition, selection, and calculation results	Reference pages
<ul style="list-style-type: none"> • Select load factor Load condition for chain conveyer application → Uniform load (U) Load factor = 1.2 (U, 24 hours/day operation) 	Page B-7~9 Table B-2: Reducer Load Classification Table B-1: Reducer Load Factor
<ul style="list-style-type: none"> • Select motor capacity Load capacity=0.7kW → Motor capacity=0.75kW 	Page A-7: Product Range of Motor
<ul style="list-style-type: none"> • Select output speed Power source frequency 50Hz, output speed 33.7r/min → 1450/33.7 = Reduction ratio 43 	Page B-38: CYCLO® GEARMOTORS Selection Tables
<ul style="list-style-type: none"> • Check output torque $T_L = \frac{9550 \times 0.7(kw)}{1450} \times 43 = 199 \text{ N}\cdot\text{m} \leq 202 \text{ N}\cdot\text{m} \rightarrow \text{OK}$ T_L=Load torque 	Page B-38: CYCLO® GEARMOTORS Selection Tables
<ul style="list-style-type: none"> • Determine reducer frame size Load factor = 1.2 ≤ 1.44 Reducer frame size & reduction ratio: 1-6105-43 	Page B-38: CYCLO® GEARMOTORS Selection Tables
<ul style="list-style-type: none"> • Check radial load Pr = TL/R ≤ Pro/Cf Pr = 199(N·m)/0.061(m) = 3262(N) ≤ 5400(N)/1 = 5400(N) → OK 	Page F-10: Allowable Radial and Axial Load
<ul style="list-style-type: none"> • Check slow speed shaft direction, mounting style, lubrication method Slow speed shaft direction: Horizontal, Mounting style: Foot mount → Nomenclature: CNHM (Grease lubrication method) 	Page B-38: CYCLO® GEARMOTORS Selection Tables
<ul style="list-style-type: none"> • Check dimension Check dimension using Dimension Tables. 	Page B-10: Nomenclature
<ul style="list-style-type: none"> • Check surrounding condition Ambient temperature: 20°C → OK 	Page B-101: Dimension Tables
<ul style="list-style-type: none"> • Check motor specification 200V, 50Hz, for indoor use → OK with standard specificationn 	Page B-3: Standard Specifications of Gearmotor
<ul style="list-style-type: none"> ■ Determine nomenclature Determine nomenclature: CNHM1-6105-43 	Page A-7: Product Range of Motor
<p>The selection is complete.</p>	Page B-10: Nomenclature

GEARMOTORS

How to Select

Selection of Load Factor

The Load Factor is rated for the characteristics of the driven machine.

The tabulated ratings are based on a running time of 10 hours per day with uniform load.

For your reference, please see method (1) and (2) shown below.

(1) Recommended Load Factor by the Driven Application.

[Load Factor] U: Uniform load M: Moderate shock H: Heavy shock

Table B-1 Reducer Load Factor

Daily duty	~3 hours/day			~10 hours/day			~24 hours/day		
	U	M	H	U	M	H	U	M	H
Load Factor	0.80	1.00	1.35	1.00	1.20	1.50	1.20	1.35	1.60

Table B-2 Recommended Load Classifications

Type of APPLICATION	Type of LOAD	Type of APPLICATION	Type of LOAD	Type of APPLICATION	Type of LOAD	Type of APPLICATION	Type of LOAD	
*Aerator		Elevators		slab conveyor	H	suction roll	U	
Agitators.		bucket - uniform load	U	small waste-conveyor-belt	U	washers & thickeners	M	
pure liquids	U	bucket - heavy load	M	small waste-conveyor-chain	M	winders	U	
liquids & solids	M	centrifugal discharge	U	sorting table	M	*Printing Presses		
liquids-variable density	M	escalators	U	tipple hoist conveyor	M	Pullers		
Blowers		freight	U	tipple hoist drive	M	barge haul		H
centrifugal	U	gravity discharge	U	transfer conveyors	M	Pumps		
lobe	M	*man lifts	M	transfer rolls	M	centrifugal		U
vane	U	*passenger	M	tray drive	M	proportioning		M
Brewing & Distilling		**Extruders(Plastics)		trimmer feed	M	reciprocating single acting, 3 or more cylinders		M
bottling machinery	U	blow molders	M	waste conveyor	M	double acting, 1 or 2 cylinders		M
brew kettles, cont. duty	U	coating	U	Machine Tools				
cookers-cont. duty	U	film	U	bending roll	M	double acting, 2 or more cylinders		M
mash tubs-cont. duty	U	pipe	U	punch press-gear driven	H	*single acting, 1 or 2 cylinders		M
scale hopper, frequent starts	M	pre-plasticizers	M	*notching press-belt driven	M	*double acting, single cylinder		M
Can Filling Machines	U	rods	U	plate planers	H	rotary-gear type		U
*Cane Knives	M	sheet	U	tapping machine	H	rotary-lobe, vane		U
Car Dumpers	H	tubing	U	other machine tools		Rubber & Plastics Industries		
Car Pullers	M	Fans		main drives	M	*crackers		H
Clarifiers	U	centrifugal	U	auxiliary drives	U	laboratory equipment		M
Classifiers	M	*cooling towers		Metal Mills				
Clay Working Machinery		induced draft	U	draw bench carriage & main drive	M	*mixing mills		H
brick press	H	*forced draft		forming machines	H	**refiners		M
briquette machine	H	induced draft	M	*pinch, dryer & scrubber rolls,		**rubber calendars		M
clay working machinery	M	large(mine, etc.)	M	reversing		**rubber mill(2 on line)		M
pug mill	M	large(industrial)	M	slitters	M	**rubber mill(3 on line)		U
Compressors		light(small diameter)	U	table conveyors-non-reversing group drives	M	**sheeter		M
centrifugal	U	Feeders		individual drives	H	*tire building machines		
lobe	M	apron	M	*table conveyors-reversing		*tire & tube press openers		
reciprocating, multi-cylinder	M	belt	M	wire drawing & flattening machine	M	*tubers & strainers		M
reciprocating, single-cylinder	H	disc	U	wire winding machine	M	**warming mills		M
Conveyors-Uniformly Loaded or Fed		reciprocating	H	Mills, Rotary Type				
apron	U	screw	M	*ball	M	Sand Muller		M
assembly	U	Food industry		**cement kilns	M	Screens		
belt	U	beet slicer	M	**dryers & coolers	M	air washing		U
bucket	U	cereal cooker	U	kilns	M	rotary-stone or gravel		M
chain	U	dough mixer	M	**pebble	M	traveling water intake		U
flight	U	meat grinders	M	**rod, plain & wedge bar	M	Sewage Disposal Equipment		
oven	U	Generators(not welding)	U	tumbling barrels	H	bar screens		U
screw	U	Hammer mills	H	Mixers				
Conveyors-Heavy Duty Not Uniformly Fed		Hoists		concrete mixers, cont.	M	chemical feeders		U
apron	M	heavy duty	H	concrete mixers, intermittent	M	collectors, circuline or straightline		U
assembly	M	medium duty	M	constant density	U	dewatering screws		M
belt	M	skip hoist	M	variable density	M	grit collectors		U
bucket	M	Laundry Washers		Oil Industry				
chain	M	reversing	M	chillers	M	scum breakers		M
flight	M	Laundry Tumblers	M	*oil well pumping		slow or rapid mixers		M
*live roll	U	Line Shaft		paraffin filter press	M	sludge collectors		U
oven	M	driving processing equipment	M	rotary kilns	M	thickeners		M
reciprocating	H	light	U	Paper Mills				
screw	M	other line shafts	U	agitators(mixers)	M	vacuum filters		M
shaker	H	Lumber Industry		barker-auxiliaries-hydraulic	M	Slab Pushers		M
Cranes(Except for Dry Dock Cranes)		barkers-hydraulic		barker-mechanical	M	*Steering Gear		
main hoists	M	burner conveyor	M	barking drum	H	Stokers		U
*bridge travel	H	chain saw & drag saw	H	beater & pulper	M	Sugar Industry		
*trolley travel	H	chain transfer	H	bleacher	U	*cane knives		M
Crusher		craneway transfer	H	calendars	M	*crushers		M
ore	H	de-barking drum	H	calendars-super	H	**mills		H
stone	H	edger feed	M	converting machine, except cutters,		Textile Industry		
**sugar	M	gang feed	H	platers	M	batchers		M
Dredges		green chain	M	conveyors	U	calendars		M
cable reels	M	live rolls	H	couch	M	cards		M
conveyors	M	log haul-locline	H	cutters-platers	H	dry cans		M
cutter head drives	H	log haul-well type	H	cylinders	M	dryers		M
jig drives	H	log turning device	H	dryers	M	dyeing machinery		M
maneuvering winches	M	main log conveyor	H	Paper Mills				
pumps	M	off bearing rolls	M	felt stretcher	M	*knitting machines		
screen drive	H	planer feed chains	M	felt whipper	H	looms		M
stackers	M	planer floor chains	M	jordans	H	mangles		M
utility winches	M	planer tilting hoist	M	log haul	H	nappers		M
*Dry Dock Cranes		re-saw merry-go-round conveyor	M	presses	U	pads		M
		roll cases	H	pulp machine reel	M	*range drives		
				stock chests	M	slashers		M
						soapers		M
						spinners		M
						tenter frames		M
						washers		M
						winders		M
						*Windlass		

Remarks: * Refer to factory. ** To be selected on basis of 24hr. service only.

Note: Table above contains reference value. Names and mechanical characteristics of the actual machine may differ from the table above.

Selection of Load Factor

(2) Recommended Load Factor Modifications for Frequent Start-Stop Operation

Please see table B-3 and B-4.

Table B-3 Number of Starts-Stops and Load Factor

Number of starts-stops (times/hour)	~3 hours/day			~10 hours/day			~24 hours/day		
	I	II	III	I	II	III	I	II	III
~10	0.80	1.00	1.20	1.00	1.10	1.35	1.20	1.25	1.50
~200	0.85	1.10	1.30	1.10	1.30	1.50	1.25	1.50	1.65
~500	0.90	1.20	1.40	1.15	1.45	1.60	1.30	1.60	1.75

The ratio of Moment of Inertia (The ratio of GD²) = $\frac{\text{Total Moment of Inertia (GD}^2\text{) as seen from the motor shaft}}{\text{Moment of Inertia (GD}^2\text{) of motor}}$

- Load Factor
- 1: Allowable ratio of Moment of Inertia (GD²) ≤ 0.3
 - 2: Allowable ratio of Moment of Inertia (GD²) ≤ 3
 - 3: Allowable ratio of Moment of Inertia (GD²) ≤ 10

- Note:
- 1. The number of starts-stops includes brake or clutch operation times.
 - 2. Consult us when starting under loaded conditions.
 - 3. Consult us when start-stop frequency exceeds 500 times/hour. Brake for high frequency use may be necessary.

Table B-4 MOTOR THERMAL RATING (C × Z)

Motor Power kW	Allowable C × Z				Motor moment of inertia kg·m ²		Motor GD ² kgf·m ²	
	(35%ED)	(35%ED~50%ED)	(50%ED~80%ED)	(80%ED~100%ED)	Standard	With brake	Standard	With brake
0.1	3200	3000	2000	1200	0.00033	0.00035	0.0013	0.0014
0.2	2200	2800	2800	2500	0.00050	0.00055	0.002	0.0022
0.25	2200	2800	2800	2500	0.00050	0.00055	0.002	0.0022
0.4	1800	2200	1500	1500	0.00065	0.00068	0.0026	0.0027
0.55	1800	2200	1500	1500	0.00101	0.00111	0.00405	0.00445
0.75	1400	1400	800	500	0.00120	0.00130	0.0048	0.0052
1.1	1400	1400	800	500	0.00185	0.00208	0.0074	0.0083
1.5	1200	1200	500	400	0.00213	0.00235	0.0085	0.0094
2.2	1000	900	400	200	0.00333	0.00373	0.0133	0.0149
3.0	1000	900	400	200	0.00700	0.00810	0.0281	0.0325
3.7	800	800	800	700	0.00848	0.00958	0.0339	0.0383
5.5	300	300	200	150	0.01143	0.01253	0.0457	0.0501
7.5	400	350	300	300	0.02675	0.03025	0.1070	0.121
11	200	200	150	150	0.03750	0.04100	0.1500	0.164

C × Z calculated by below steps (1) ~ (3) must be less than allowable C × Z listed in Table B-4.

(1) Calculate C from formula below.

[SI units] $C = \frac{J_M + J_L}{J_M}$

[Gravitational units] $C = \frac{GD_M^2 + GD_L^2}{GD_M^2}$

J_M; Moment of inertia of motor (kg·m²)
J_L; Total moment of inertia (excluding motor) at motor shaft (kg·m²)

GD_M²; GD² of motor (kgf·m²)
GD_L²; Total GD² (excluding motor) at motor shaft (kgf·m²)

Continues to the next page.

Selection of Load Factor

(2) Calculate Z (number of startup times/hour).

- (a) Assume that one operating period consists of "on time" t_a (sec), "off time" t_b (sec) and the motor is started n_r (times/cycle)

$$Z_r = \frac{3600n_r}{t_a + t_b} \quad (\text{times/hr})$$

- (b) When inching, n_i (times/cycle) is included in 1 cycle ($t_a + t_b$), the number of inching times per hour Z_i , and then included in the number of starts.

$$Z_i = \frac{3600n_i}{t_a + t_b} \quad (\text{times/hr})$$

- (c) Calculate Z (times/hr) by (a) and (b).

$$Z = Z_r + \frac{1}{2} Z_i = \frac{3600n_r}{t_a + t_b} \cdot \left(n_r + \frac{1}{2} n_i \right) \quad (\text{times/hr})$$

(3) Calculate C multiplied by Z.

Use the C obtained in step (1) and Z in step (2).

(4) Obtain the duty cycle %ED and check with table above.

$$\%ED = \frac{t_a}{t_a + t_b} \times 100$$

Nomenclature

Slow Speed Shaft Direction	
Horizontal, slow speed shaft level	H
Vertical, slow speed shaft down	V
Vertically, slow speed shaft up	W
Universal mounting	N

Mounting style	
Foot	H
V flange	V
Flange	F

Type of Input	
Gearmotor	M
With adaptor	JM

Special Specifications	
Standard specification	blank
Special specification	S

		Motor Capacity Symbol					
4P	Capacity symbol	01	02	03	05	08	1
	kW (HP)	0.1 (1/8)	0.2 (1/4)	0.25 (1/3)	0.4 (1/2)	0.55 (3/4)	0.75 (1)
	Capacity symbol	1H	2	3	4	5	8
	kW (HP)	1.1 (1.5)	1.5 (2)	2.2 (3)	3.0 (4)	3.7 (5)	5.5 (7.5)
	Capacity symbol	10	15	20	25	30	40
	kW (HP)	7.5 (10)	11 (15)	15 (20)	18.5 (25)	22 (30)	30 (40)
6P	Capacity symbol	50	60	75	100		
	kW (HP)	37 (50)	45 (60)	55 (75)	75 (100)		
	Capacity symbol	016	026	036	056	086	16
	kW (HP)	0.1 (1/8)	0.2 (1/4)	0.25 (1/3)	0.4 (1/2)	0.55 (3/4)	0.75 (1)
	Capacity symbol	1H6	26	36	46	56	86
	kW (HP)	1.1 (1.5)	1.5 (2)	2.2 (3)	3.0 (4)	3.7 (5)	5.5 (7.5)
	Capacity symbol	106	156	206	256	306	406
	kW (HP)	7.5 (10)	11 (15)	15 (20)	18.5 (25)	22 (30)	30 (40)
	Capacity symbol	506	606	756	1006	1256	1506
	kW (HP)	37 (50)	45 (60)	55 (75)	75 (100)	90 (125)	110 (150)
	Capacity symbol	1756					
	kW (HP)	132 (175)					

Shaft specification	
Metric JIS (Standard)	-
Inch size	Y
Metric DIN	G

Suffix		
Standard	-	Low Backlash
Light Heavy Radial R1	With AF (inverter) motor	AV
High Cap. Brg. Ductile Casing R2	Servo Motor	SV
Baseplate BP	DC Motor	DV
HH Type Ceiling H1	High Efficiency Motor	ES
Modification Left Wall H2	Torque Limiter	TL
Modification Right Wall H3		

With or Without Brake	
Without brake	-
With brake	B

Frame size
(Refer to Selection Tables starting from page B-13.)

Nominal ratio

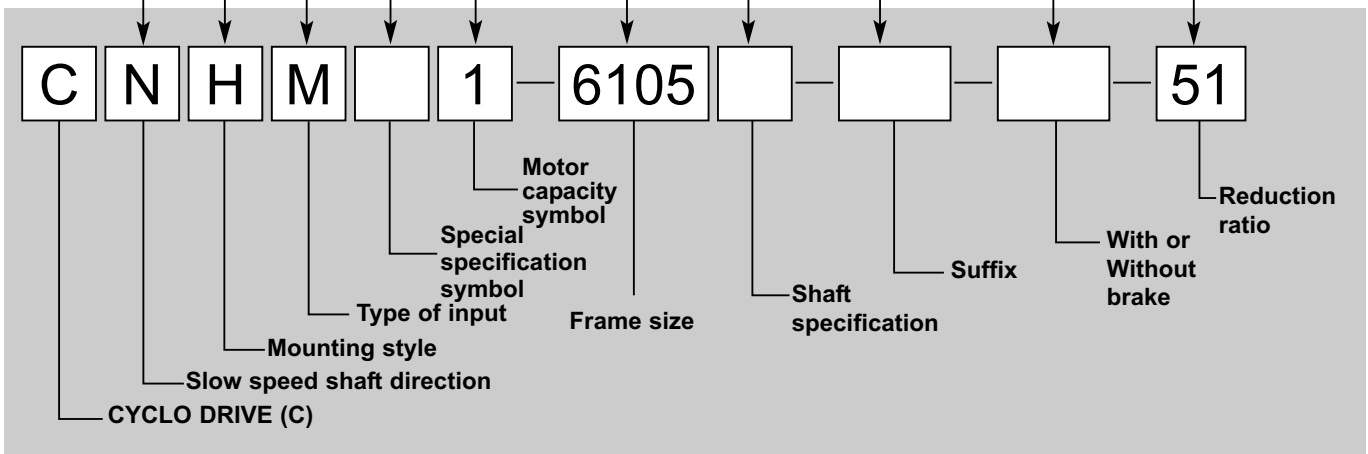

GEARMOTORS
How to Select

Nomenclature and Product Examples

Nomenclature Examples (Gearmotor)

Example 1. CNHM2 - 6115 - 29

C:	Model	- CYCLO® DRIVE
N:	Slow speed shaft direction	- Universal direction
H:	Mounting style	- Foot
M:	Type of input	- Gearmotor type
2:	Motor capacity	- 1.5kW
6115:	Frame size	- 6115
29:	Reduction ratio	- 29

Example 2. CVVM5 - 6195DA - B - 377

C:	Model	- CYCLO® DRIVE
V:	Slow speed shaft direction	- Vertical mounting
V:	Mounting style	- V flange
M:	Type of input	- Gearmotor type
5:	Motor capacity	- 3.7kW
6195DA:	Frame size	- 6115
B:	Brake	- With brake
377:	Reduction ratio	- 377

GEARMOTORS
How to Select

Product and Nomenclature Symbol Examples (Gearmotor)

Standard and various application products of CYCLO® GEARMOTOR are classified by their nomenclature symbol as below. Refer to specific catalogs or consult us for details on our application products.

CYCLO® GEARMOTORS

CHHM
(CNHM)

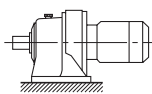

CHFM
(CNFM)

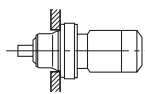

CHVM
(CNVM)

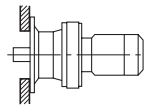

CVHM
(CNHM)

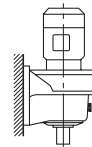

CVFM
(CNFM)

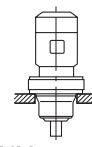

CVVM
(CNVM)

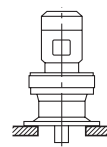

CWHM
(CNHM)

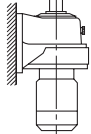

CWFM
(CNFM)

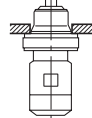

CWVM
(CNVM)

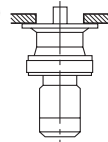

CHHJM
(CNHJM)

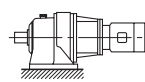

With Adaptor

CHFJM
(CNFJM)

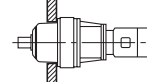

With Adaptor

CVVJM
(CNVJM)

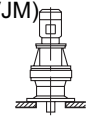

With Adaptor

CYCLO® GEARMOTOR Application Products

CHHXM
(CNHXM)

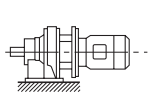

Input Side Hollow Shaft

CHFXM
(CNFXM)

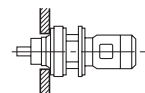

Input Side Hollow Shaft

CVVXM
(CNVXM)

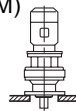

Input Side Hollow Shaft

CHHPM

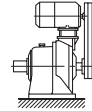

Top Mount Type

CVVPM

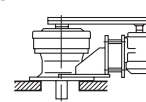

Side Mount Type

CPM

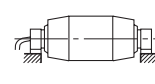

Cyclo Motor Pulley

CHHBM

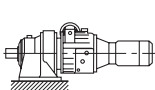

Beier Cyclo Variator

CHFBM

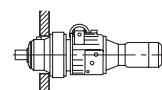

Beier Cyclo Variator

CVVBM



Beier Cyclo Variator

CHHCM



Cyclo Pack with Clutch Brake

C11WM

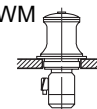

Cyclo Capstan

C10CM

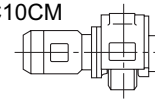

Cyclo Wheel

C14VM

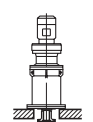

Vertical Special Base Mount

C15VM

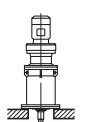

C17VM

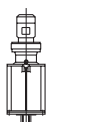

Vertical Special Base Mount

C18VM

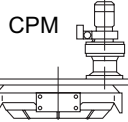
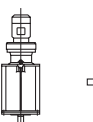

Center Post Type

M E M O

GEARMOTORS

How to
Select

B CYCLO® GEARMOTORS

2. Selection Tables

Selection Tables Gearmotors

0.1 kW		n ₁ : Motor Speed					
		Hz		50Hz		60Hz	
		P		4	6	4	6
n ₁		r/min		1450	980	1750	1165

50Hz						60Hz						Nomenclature			Page of Dimension Sheet		
Output Speed n ₂	Output Torque Tout		Allowable Radial Load Pro		SF	Output Speed n ₂	Output Torque Tout		Allowable Radial Load Pro		SF	Input Capacity Symbol	Frame Size	Reduction Ratio	CNHM	CNFM	CNVM
r/min	N·m	kgf·m	N	kgf		r/min	N·m	kgf·m	N	kgf					CHHM	CHFM	CVVM
242	3.75	0.383	804	82.0	2.00	292	3.11	0.317	756	77.1	2.00	01 -	6060	- 6	B-100	B-116	B-135
			804	82.0	2.86				756	77.1	2.86	01 -	6065	- 6	B-100	B-116	B-135
181	5.01	0.510	921	94	2.00	219	4.15	0.423	866	88	2.00	01 -	6060	- 8	B-100	B-116	B-135
			921	94	2.86				866	88	2.86	01 -	6065	- 8	B-100	B-116	B-135
132	6.88	0.702	1180	120	2.00	159	5.70	0.581	1180	120	2.00	01 -	6060	- 11	B-100	B-116	B-135
			1180	120	2.86				1180	120	2.86	01 -	6065	- 11	B-100	B-116	B-135
112	8.1	0.83	1180	120	2.00	135	6.7	0.69	1180	120	2.00	01 -	6060	- 13	B-100	B-116	B-135
			1180	120	2.86				1180	120	2.86	01 -	6065	- 13	B-100	B-116	B-135
96.7	9.4	0.96	1180	120	2.00	117	7.8	0.79	1180	120	2.00	01 -	6060	- 15	B-100	B-116	B-135
			1180	120	2.86				1180	120	2.86	01 -	6065	- 15	B-100	B-116	B-135
85.3	10.6	1.08	1180	120	2.00	103	8.8	0.90	1180	120	2.00	01 -	6060	- 17	B-100	B-116	B-135
			1180	120	2.82				1180	120	2.86	01 -	6065	- 17	B-100	B-116	B-135
69.0	13.1	1.34	1180	120	1.83	83.3	10.9	1.11	1180	120	2.00	01 -	6060	- 21	B-100	B-116	B-135
			1180	120	2.28				1180	120	2.34	01 -	6065	- 21	B-100	B-116	B-135
58.0	15.6	1.59	1180	120	1.10	70.0	13.0	1.32	1180	120	1.10	01 -	6060	- 25	B-100	B-116	B-135
			1180	120	1.66				1180	120	1.66	01 -	6065	- 25	B-100	B-116	B-135
			1770	180	2.30				1770	180	2.30	01 -	6070	- 25	B-100	B-116	B-135
			1770	180	2.94				1770	180	2.94	01 -	6075	- 25	B-100	B-116	B-135
50.0	18.1	1.85	1180	120	1.10	60.3	15.0	1.53	1180	120	1.10	01 -	6060	- 29	B-100	B-116	B-135
			1180	120	1.65				1180	120	1.66	01 -	6065	- 29	B-100	B-116	B-135
			1770	180	2.26				1770	180	2.26	01 -	6070	- 29	B-100	B-116	B-135
			1770	180	2.86				1770	180	2.86	01 -	6075	- 29	B-100	B-116	B-135
41.4	21.9	2.23	1180	120	1.10	50.0	18.1	1.85	1180	120	1.10	01 -	6060	- 35	B-100	B-116	B-135
			1180	120	1.37				1180	120	1.43	01 -	6065	- 35	B-100	B-116	B-135
			1770	180	2.05				1770	180	2.11	01 -	6070	- 35	B-100	B-116	B-135
			1770	180	2.72				1770	180	2.79	01 -	6075	- 35	B-100	B-116	B-135
33.7	26.9	2.74	1180	120	1.12	40.7	22.3	2.27	1180	120	1.13	01 -	6065	- 43	B-100	B-116	B-135
			1770	180	1.67				1770	180	1.70	01 -	6070	- 43	B-100	B-116	B-135
			1770	180	2.23				1770	180	2.26	01 -	6075	- 43	B-100	B-116	B-135
			2560	261	2.50				2560	261	2.50	01 -	6080	- 43	B-100	B-116	B-135
28.4	31.9	3.25	1770	180	1.00	34.3	26.4	2.70	1770	180	1.00	01 -	6070	- 51	B-100	B-116	B-135
			1770	180	1.43				1770	180	1.43	01 -	6075	- 51	B-100	B-116	B-135
			2560	261	1.92				2560	261	1.92	01 -	6080	- 51	B-100	B-116	B-135
			2560	261	2.41				2560	261	2.41	01 -	6085	- 51	B-100	B-116	B-135
24.6	36.9	3.76	1770	180	1.00	30.0	30.6	3.12	1770	180	1.00	01 -	6070	- 59	B-100	B-116	B-135
			1770	180	1.36				1770	180	1.36	01 -	6075	- 59	B-100	B-116	B-135
			2560	261	1.85				2560	261	1.85	01 -	6080	- 59	B-100	B-116	B-135
			2560	261	2.34				2560	261	2.34	01 -	6085	- 59	B-100	B-116	B-135
20.4	44.4	4.53	2560	261	1.20	24.6	36.8	3.75	2560	261	1.20	01 -	6080	- 71	B-100	B-116	B-135
			2560	261	1.65				2560	261	1.87	01 -	6085	- 71	B-100	B-116	B-135
			3340	340	2.52				3340	340	2.52	01 -	6090	- 71	B-100	B-116	B-135
			3340	340	2.78				3340	340	3.01	01 -	6095	- 71	B-100	B-116	B-135
16.7	54.4	5.55	2560	261	1.21	20.0	45.10	4.600	2560	261	1.21	01 -	6085	- 87	B-100	B-116	B-135
			3340	340	2.11				3340	340	2.11	01 -	6090	- 87	B-100	B-116	B-135
			3340	340	2.63				3340	340	3.01	01 -	6095	- 87	B-100	B-116	B-135
13.9	24.0	2.45	1180	120	*1	16.8	24.0	2.45	1180	120	*1	01 -	6060DA	- 104	B-108	B-124	B-143
	30.0	3.06	1180	120	*1		30.0	3.06	1180	120	*1	01 -	6065DA	- 104	B-108	B-124	B-143
	45.0	4.59	1770	180	*1		45.0	4.59	1770	180	*1	01 -	6070DA	- 104	B-108	B-124	B-143
			1770	180	0.97				1770	180	1.17	01 -	6075DA	- 104	B-108	B-124	B-143
	61.6	6.28	3340	340	2.43		51.1	5.21	3340	340	2.94	01 -	6090DA	- 104	B-108	B-124	B-143
		3340	340	2.93			3340	340	3.54	01 -	6095DA	- 104	B-108	B-124	B-143		

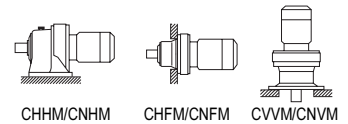

GEARMOTORS

Selection Tables
0.1 kW

1. Combinations in **bold** are the recommended models for operations for 10 hours/day with uniform load (service factor is about 1.0 for motor rating at 50Hz).
2. Motor slippage may affect n₁ and n₂. Refer to technical data for details.
3. CNHM, CHHM, CNFM, CHFM, CNVM, and CVVM indicate types. Refer to page B-10 for details.
4. Lubrication method is different for each model. Refer to "Lubrication" section in page F-4~F-5 for details.
5. "6" at the end of "input capacity symbol" indicates models with 6P motor. Other models come with 4P motor.

Selection Tables Gearmotors

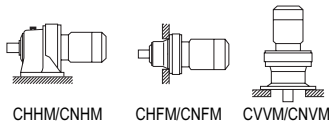

0.1 kW	Hz		50Hz		60Hz	
	P		4	6	4	6
	n ₁	r/min	1450	980	1750	1165



n₁: Motor Speed

50Hz						60Hz						Nomenclature			Page of Dimension Sheet		
Output Speed n ₂ r/min	Output Torque T _{out}		Allowable Radial Load Pro		SF	Output Speed n ₂ r/min	Output Torque T _{out}		Allowable Radial Load Pro		SF	Input Capacity - Symbol	Frame Size	Reduction Ratio	CNHM	CNFM	CNVM
	N·m	kgf·m	N	kgf			N·m	kgf·m	N	kgf							
12.2	74.5	7.59	3340	340	1.25	14.7	61.7	6.29	3340	340	1.51	01 - 6090	- 119	B-100	B-116	B-135	
			3340	340	1.45				3340	340		01 - 6095	- 119	B-100	B-116	B-135	
12.0	24.0	2.45	1180	120	*1	14.5	24.0	2.45	1180	120	*1	01 - 6060DA	- 121	B-108	B-124	B-143	
	30.0	3.06	1140	116	*1		30.0	3.06	1140	116	*1	01 - 6065DA	- 121	B-108	B-124	B-143	
	45.0	4.59	1770	180	*1		45.0	4.59	1770	180	*1	01 - 6070DA	- 121	B-108	B-124	B-143	
	50.8	5.18	1770	180	*1		50.8	5.18	1770	180	*1	01 - 6075DA	- 121	B-108	B-124	B-143	
	71.7	7.31	3340	340	2.09		59.4	6.06	3340	340	2.52	01 - 6090DA	- 121	B-108	B-124	B-143	
			3340	340	2.24				3340	340	2.70	01 - 6095DA	- 121	B-108	B-124	B-143	
10.1	24.0	2.45	1180	120	*1	12.2	24.0	2.45	1180	120	*1	01 - 6060DA	- 143	B-108	B-124	B-143	
	30.0	3.06	1180	120	*1		30.0	3.06	1180	120	*1	01 - 6065DA	- 143	B-108	B-124	B-143	
	45.0	4.59	1770	180	*1		45.0	4.59	1770	180	*1	01 - 6070DA	- 143	B-108	B-124	B-143	
	60.0	6.12	1770	180	*1		60.0	6.12	1770	180	*1	01 - 6075DA	- 143	B-108	B-124	B-143	
			3340	340	1.77				3340	340	2.14	01 - 6090DA	- 143	B-108	B-124	B-143	
	84.8	8.64	3340	340	2.16		70.2	7.16	3340	340	2.61	01 - 6095DA	- 143	B-108	B-124	B-143	
			5400	550	2.95				5400	550	3.56	01 - 6100DA	- 143	B-108	B-124	B-143	
8.79	24.0	2.45	1180	120	*1	10.6	24.0	2.45	1180	120	*1	01 - 6060DA	- 165	B-108	B-124	B-143	
	30.0	3.06	1180	120	*1		30.0	3.06	1180	120	*1	01 - 6065DA	- 165	B-108	B-124	B-143	
	45.0	4.59	1770	180	*1		45.0	4.59	1770	180	*1	01 - 6070DA	- 165	B-108	B-124	B-143	
	60.0	6.12	1770	180	*1		60.0	6.12	1770	180	*1	01 - 6075DA	- 165	B-108	B-124	B-143	
			3340	340	1.53				3340	340	1.85	01 - 6090DA	- 165	B-108	B-124	B-143	
	97.8	9.97	3340	340	2.04		81.0	8.26	3340	340	2.47	01 - 6095DA	- 165	B-108	B-124	B-143	
			5400	550	2.56				5400	550	3.08	01 - 6100DA	- 165	B-108	B-124	B-143	
7.44	24.0	2.45	1180	120	*1	8.97	24.0	2.45	1180	120	*1	01 - 6060DA	- 195	B-108	B-124	B-143	
	30.0	3.06	1180	120	*1		30.0	3.06	1180	120	*1	01 - 6065DA	- 195	B-108	B-124	B-143	
	45.0	4.59	1770	180	*1		45.0	4.59	1770	180	*1	01 - 6070DA	- 195	B-108	B-124	B-143	
	60.0	6.12	1770	180	*1		60.0	6.12	1770	180	*1	01 - 6075DA	- 195	B-108	B-124	B-143	
			3340	340	1.30				3340	340	1.57	01 - 6090DA	- 195	B-108	B-124	B-143	
	116	11.8	3340	340	1.73		95.8	9.76	3340	340	2.09	01 - 6095DA	- 195	B-108	B-124	B-143	
			5400	550	2.16				5400	550	2.61	01 - 6100DA	- 195	B-108	B-124	B-143	
			5400	550	2.60				5400	550	3.13	01 - 6105DA	- 195	B-108	B-124	B-143	
6.28	24.0	2.45	1180	120	*1	7.58	24.0	2.45	1180	120	*1	01 - 6060DA	- 231	B-108	B-124	B-143	
	30.0	3.06	1180	120	*1		30.0	3.06	1180	120	*1	01 - 6065DA	- 231	B-108	B-124	B-143	
	45.0	4.59	1770	180	*1		45.0	4.59	1770	180	*1	01 - 6070DA	- 231	B-108	B-124	B-143	
	60.0	6.12	1770	180	*1		60.0	6.12	1770	180	*1	01 - 6075DA	- 231	B-108	B-124	B-143	
			3340	340	1.10				3340	340	1.32	01 - 6090DA	- 231	B-108	B-124	B-143	
			3340	340	1.46				3340	340	1.76	01 - 6095DA	- 231	B-108	B-124	B-143	
	137	14.0	5400	550	1.83		113	11.6	5400	550	2.20	01 - 6100DA	- 231	B-108	B-124	B-143	
			5400	550	2.19				5400	550	2.64	01 - 6105DA	- 231	B-108	B-124	B-143	
5.31	24.0	2.45	1180	120	*1	6.41	24.0	2.45	1180	120	*1	01 - 6060DA	- 273	B-108	B-124	B-143	
	30.0	3.06	1180	120	*1		30.0	3.06	1180	120	*1	01 - 6065DA	- 273	B-108	B-124	B-143	
	45.0	4.59	1770	180	*1		45.0	4.59	1770	180	*1	01 - 6070DA	- 273	B-108	B-124	B-143	
	60.0	6.12	1770	180	*1		60.0	6.12	1770	180	*1	01 - 6075DA	- 273	B-108	B-124	B-143	
			3340	340	1.24				3340	340	1.49	01 - 6095DA	- 273	B-108	B-124	B-143	
	162	16.5	5400	550	1.54		134	13.7	5400	550	1.86	01 - 6100DA	- 273	B-108	B-124	B-143	
			5400	550	1.85				5400	550	2.24	01 - 6105DA	- 273	B-108	B-124	B-143	

GEARMOTORS
Selection Tables
0.1 kW

- "*2" indicate models manufactured with reducer and motor separately mounted on a common baseplate (horizontal shaft direction) or on an adaptor (vertical shaft direction). Consult us for details, including dimensions.
- Allowable radial load (Pro) is the value at the midpoint of the slow speed shaft.
- "*3" indicate models with reduction ratios equal to nominal ratio. Refer to Table A-3 "6000SK Series (Actual Reduction Ratio)" on page A-4 for actual reduction ratio. Indicated reduction ratio is the same as actual reduction ratio for other models.
- Maintain torque load during operation within "Output torque" in the table for models with "*" in the SF column. They cannot be operated with 100% motor rating.

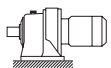
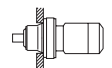
Selection Tables Gearmotors

0.1 kW		n ₁ : Motor Speed													
		Hz		50Hz		60Hz									
		P		4	6	4	6								
n ₁	r/min	1450	980	1750	1165										
		  					CHHM/CNHM		CHFM/CNFM		CVVM/CNVM				
50Hz					60Hz					Nomenclature			Page of Dimension Sheet		
Output Speed n ₂	Output Torque Tout	Allowable Radial Load Pro		SF	Output Speed n ₂	Output Torque Tout	Allowable Radial Load Pro		SF	Input Capacity Symbol	Frame Size	Reduction Ratio	CNHM	CNFM	CNVM
r/min	N·m	kgf·m	N	kgf	r/min	N·m	kgf·m	N	kgf				CHHM	CHFM	CVVM
4.55	24.0	2.45	1180	120	*1	5.49	24.0	2.45	1180	120	*1	01 - 6060DA - 319	B-108	B-124	B-143
	30.0	3.06	1180	120	*1		30.0	3.06	1180	120	*1	01 - 6065DA - 319	B-108	B-124	B-143
	45.0	4.59	1770	180	*1		45.0	4.59	1770	180	*1	01 - 6070DA - 319	B-108	B-124	B-143
	60.0	6.12	1770	180	*1		60.0	6.12	1770	180	*1	01 - 6075DA - 319	B-108	B-124	B-143
	150	15.3	3290	336	*1		150	15.3	3290	336	*1	01 - 6090DA - 319	B-108	B-124	B-143
			3220	328	1.06				3280	334	1.28	01 - 6095DA - 319	B-108	B-124	B-143
	189	19.3	5400	550	1.32	157	16.0	5400	550	1.60	01 - 6100DA - 319	B-108	B-124	B-143	
		5400	550	1.59	5400			550	1.91	01 - 6105DA - 319	B-108	B-124	B-143		
		9810	1000	2.75	9810			1000	3.32	01 - 6120DA - 319	B-108	B-124	B-143		
3.85	24.0	2.45	1180	120	*1	4.64	24.0	2.45	1180	120	*1	01 - 6060DA - 377	B-108	B-124	B-143
	30.0	3.06	1180	120	*1		30.0	3.06	1180	120	*1	01 - 6065DA - 377	B-108	B-124	B-143
	45.0	4.59	1770	180	*1		45.0	4.59	1770	180	*1	01 - 6070DA - 377	B-108	B-124	B-143
	60.0	6.12	1770	180	*1		60.0	6.12	1770	180	*1	01 - 6075DA - 377	B-108	B-124	B-143
	150	15.3	3290	336	*1		150	15.3	3290	336	*1	01 - 6090DA - 377	B-108	B-124	B-143
			3150	321	0.89				3230	329	1.08	01 - 6095DA - 377	B-108	B-124	B-143
		5400	550	1.12	185	18.9	5400	550	1.35	01 - 6100DA - 377	B-108	B-124	B-143		
		5400	550	1.34			5400	550	1.62	01 - 6105DA - 377	B-108	B-124	B-143		
223	22.8	9810	1000	2.33			9810	1000	2.81	01 - 6120DA - 377	B-108	B-124	B-143		
		9810	1000	2.33			9810	1000	2.81	01 - 6120DB - 377	B-108	B-124	B-143		
		9810	1000	2.82			9810	1000	3.40	01 - 6125DA - 377	B-108	B-124	B-143		
3.07	24.0	2.45	1180	120	*1	3.70	24.0	2.45	1180	120	*1	01 - 6060DA - 473	B-108	B-124	B-143
	30.0	3.06	1180	120	*1		30.0	3.06	1180	120	*1	01 - 6065DA - 473	B-108	B-124	B-143
	45.0	4.59	1770	180	*1		45.0	4.59	1770	180	*1	01 - 6070DA - 473	B-108	B-124	B-143
	60.0	6.12	1660	169	*1		60.0	6.12	1660	169	*1	01 - 6075DA - 473	B-108	B-124	B-143
	150	15.3	3310	338	*1		150	15.3	3310	338	*1	01 - 6090DA - 473	B-108	B-124	B-143
	200	20.4	3220	328	*1		200	20.4	3220	328	*1	01 - 6095DA - 473	B-108	B-124	B-143
		5400	550	1.07			5400	550	1.29	01 - 6105DA - 473	B-108	B-124	B-143		
	280	28.6	9810	1000	1.87	232	23.7	9810	1000	2.26	01 - 6120DA - 473	B-108	B-124	B-143	
		9810	1000	2.25	9810			1000	2.71	01 - 6125DA - 473	B-108	B-124	B-143		
2.59	24.0	2.45	1180	120	*1	3.13	24.0	2.45	1180	120	*1	01 - 6060DA - 559	B-108	B-124	B-143
	30.0	3.06	1180	120	*1		30.0	3.06	1180	120	*1	01 - 6065DA - 559	B-108	B-124	B-143
	45.0	4.59	1770	180	*1		45.0	4.59	1770	180	*1	01 - 6070DA - 559	B-108	B-124	B-143
	60.0	6.12	1660	169	*1		60.0	6.12	1660	169	*1	01 - 6075DA - 559	B-108	B-124	B-143
	150	15.3	3310	338	*1		150	15.3	3310	338	*1	01 - 6090DA - 559	B-108	B-124	B-143
	200	20.4	3220	328	*1		200	20.4	3220	328	*1	01 - 6095DA - 559	B-108	B-124	B-143
		5400	550	*1	250	25.5	5400	550	*1	01 - 6100DA - 559	B-108	B-124	B-143		
		4380	446	0.91			5400	550	1.09	01 - 6105DA - 559	B-108	B-124	B-143		
	331	33.8	9810	1000	1.58	275	28.0	9810	1000	1.91	01 - 6120DA - 559	B-108	B-124	B-143	
		9810	1000	1.90	9810			1000	2.29	01 - 6125DA - 559	B-108	B-124	B-143		
2.23	45.0	4.59	1770	180	*1	2.70	45.0	4.59	1770	180	*1	01 - 6070DA - 649	B-108	B-124	B-143
	57.4	5.85	1580	161	*1		57.4	5.85	1580	161	*1	01 - 6075DA - 649	B-108	B-124	B-143
	146	14.9	3300	336	*1		146	14.9	3300	336	*1	01 - 6090DA - 649	B-108	B-124	B-143
	250	25.5	5400	550	*1		250	25.5	5400	550	*1	01 - 6100DA - 649	B-108	B-124	B-143
	296	30.2	5090	519	*1		296	30.2	5090	519	*1	01 - 6105DA - 649	B-108	B-124	B-143
			9810	1000	1.36				9810	1000	1.65	01 - 6120DA - 649	B-108	B-124	B-143
	385	39.2	9810	1000	1.64	319	32.5	9810	1000	1.98	01 - 6125DA - 649	B-108	B-124	B-143	
1.98	24.0	2.45	1180	120	*1	2.39	24.0	2.45	1180	120	*1	01 - 6060DA - 731	B-108	B-124	B-143
	30.0	3.06	1180	120	*1		30.0	3.06	1180	120	*1	01 - 6065DA - 731	B-108	B-124	B-143
	45.0	4.59	1770	180	*1		45.0	4.59	1770	180	*1	01 - 6070DA - 731	B-108	B-124	B-143
	60.0	6.12	1660	169	*1		60.0	6.12	1660	169	*1	01 - 6075DA - 731	B-108	B-124	B-143
	150	15.3	3310	338	*1		150	15.3	3310	338	*1	01 - 6090DA - 731	B-108	B-124	B-143
	200	20.4	3220	328	*1		200	20.4	3220	328	*1	01 - 6095DA - 731	B-108	B-124	B-143
		5400	550	*1	250	25.5	5400	550	*1	01 - 6100DA - 731	B-108	B-124	B-143		
		5400	550	*1			5400	550	*1	01 - 6105DA - 731	B-108	B-124	B-143		
250	25.5	5400	550	*1			9810	1000	1.46	01 - 6120DA - 731	B-108	B-124	B-143		
300	30.6	5400	550	*1			9810	1000	1.75	01 - 6125DA - 731	B-108	B-124	B-143		
	433	44.2	9810	1000	1.21	359	36.6	9810	1000	1.46	01 - 6120DA - 731	B-108	B-124	B-143	
		9810	1000	1.45	9810			1000	1.75	01 - 6125DA - 731	B-108	B-124	B-143		

1. Combinations in **bold** are the recommended models for operations for 10 hours/day with uniform load (service factor is about 1.0 for motor rating at 50Hz).
2. Motor slippage may affect n₁ and n₂. Refer to technical data for details.
3. CNHM, CHHM, CNFM, CHFM, CNVM, and CVVM indicate types. Refer to page B-10 for details.
4. Lubrication method is different for each model. Refer to "Lubrication" section in page F-4~F-5 for details.
5. "6" at the end of "input capacity symbol" indicates models with 6P motor. Other models come with 4P motor.

Selection Tables Gearmotors

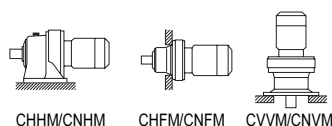



<h2>0.1 kW</h2>	Hz		50Hz		60Hz	
	P		4	6	4	6
	n ₁	r/min	1450	980	1750	1165



n₁: Motor Speed

50Hz					60Hz					Nomenclature			Page of Dimension Sheet				
Output Speed n ₂ r/min	Output Torque T _{out}		Allowable Radial Load Pro		SF	Output Speed n ₂ r/min	Output Torque T _{out}		Allowable Radial Load Pro		SF	Input Capacity - Symbol	Frame Size	Reduction Ratio	CNHM	CNFM	CNVM
	N·m	kgf·m	N	kgf			N·m	kgf·m	N	kgf							
1.72	24.0	2.45	1180	120	*1	2.08	24.0	2.45	1180	120	*1	01 - 6060DA	- 841	B-108	B-124	B-143	
	30.0	3.06	1180	120	*1		30.0	3.06	1180	120	*1	01 - 6065DA	- 841	B-108	B-124	B-143	
	45.0	4.59	1770	180	*1		45.0	4.59	1770	180	*1	01 - 6070DA	- 841	B-108	B-124	B-143	
	60.0	6.12	1770	180	*1		60.0	6.12	1770	180	*1	01 - 6075DA	- 841	B-108	B-124	B-143	
	150	15.3	3290	336	*1		150	15.3	3290	336	*1	01 - 6090DA	- 841	B-108	B-124	B-143	
	200	20.4	3200	326	*1		200	20.4	3200	326	*1	01 - 6095DA	- 841	B-108	B-124	B-143	
	250	25.5	5400	550	*1		250	25.5	5400	550	*1	01 - 6100DA	- 841	B-108	B-124	B-143	
300	30.6	5400	550	*1	300	30.6	5400	550	*1	01 - 6105DA	- 841	B-108	B-124	B-143			
	499	50.8	9810	1000	1.04		413	42.1	9810	1000	1.26	01 - 6120DA	- 841	B-108	B-124	B-143	
			9810	1000	1.26				9810	1000	1.53	01 - 6125DA	- 841	B-108	B-124	B-143	
1.45	45.0	4.59	1770	180	*1	1.74	45.0	4.59	1770	180	*1	01 - 6070DA	- 1003	B-108	B-124	B-143	
	57.4	5.85	1580	161	*1		57.4	5.85	1580	161	*1	01 - 6075DA	- 1003	B-108	B-124	B-143	
	146	14.9	3300	336	*1		146	14.9	3300	336	*1	01 - 6090DA	- 1003	B-108	B-124	B-143	
	250	25.5	5400	550	*1		250	25.5	5400	550	*1	01 - 6100DA	- 1003	B-108	B-124	B-143	
	296	30.2	5090	519	*1		296	30.2	5090	519	*1	01 - 6105DA	- 1003	B-108	B-124	B-143	
	595	60.6	9810	1000	1.06		493	50.2	9810	1000	1.28	01 - 6125DA	- 1003	B-108	B-124	B-143	
1.16	24.0	2.45	1180	120	*1	1.40	24.0	2.45	1180	120	*1	01 - 6060DA	- 1247	B-108	B-124	B-143	
	30.0	3.06	1180	120	*1		30.0	3.06	1180	120	*1	01 - 6065DA	- 1247	B-108	B-124	B-143	
	45.0	4.59	1770	180	*1		45.0	4.59	1770	180	*1	01 - 6070DA	- 1247	B-108	B-124	B-143	
	60.0	6.12	1660	169	*1		60.0	6.12	1660	169	*1	01 - 6075DA	- 1247	B-108	B-124	B-143	
	150	15.3	3310	338	*1		150	15.3	3310	338	*1	01 - 6090DA	- 1247	B-108	B-124	B-143	
	200	20.4	3220	328	*1		200	20.4	3220	328	*1	01 - 6095DA	- 1247	B-108	B-124	B-143	
	250	25.5	5400	550	*1		250	25.5	5400	550	*1	01 - 6100DA	- 1247	B-108	B-124	B-143	
	300	30.6	5400	550	*1		300	30.6	5400	550	*1	01 - 6105DA	- 1247	B-108	B-124	B-143	
	525	53.5	9810	1000	*1		525	53.5	9810	1000	*1	01 - 6120DA	- 1247	B-108	B-124	B-143	
739	75.3	9810	1000	0.85	612	62.4	9810	1000	1.03	01 - 6125DA	- 1247	B-108	B-124	B-143			
0.980	150	15.3	3310	338	*1	1.18	150	15.3	3310	338	*1	01 - 6090DA	- 1479	B-108	B-124	B-143	
	193	19.6	3240	330	*1		193	19.6	3240	330	*1	01 - 6095DA	- 1479	B-108	B-124	B-143	
	250	25.5	5400	550	*1		250	25.5	5400	550	*1	01 - 6100DA	- 1479	B-108	B-124	B-143	
	300	30.6	4780	488	*1		300	30.6	4780	488	*1	01 - 6105DA	- 1479	B-108	B-124	B-143	
	525	53.5	9780	997	*1		525	53.5	9780	997	*1	01 - 6120DA	- 1479	B-108	B-124	B-143	
	630	64.2	9560	974	*1		630	64.2	9560	974	*1	01 - 6125DA	- 1479	B-108	B-124	B-143	
0.784	24.0	2.45	1180	120	*1	0.946	24.0	2.45	1180	120	*1	01 - 6060DA	- 1849	B-108	B-124	B-143	
	30.0	3.06	1180	120	*1		30.0	3.06	1180	120	*1	01 - 6065DA	- 1849	B-108	B-124	B-143	
	45.0	4.59	1770	180	*1		45.0	4.59	1770	180	*1	01 - 6070DA	- 1849	B-108	B-124	B-143	
	60.0	6.12	1660	169	*1		60.0	6.12	1660	169	*1	01 - 6075DA	- 1849	B-108	B-124	B-143	
	150	15.3	3310	338	*1		150	15.3	3310	338	*1	01 - 6090DA	- 1849	B-108	B-124	B-143	
	200	20.4	3220	328	*1		200	20.4	3220	328	*1	01 - 6095DA	- 1849	B-108	B-124	B-143	
	250	25.5	5400	550	*1		250	25.5	5400	550	*1	01 - 6100DA	- 1849	B-108	B-124	B-143	
	300	30.6	5400	550	*1		300	30.6	5400	550	*1	01 - 6105DA	- 1849	B-108	B-124	B-143	
	525	53.5	9810	1000	*1		525	53.5	9810	1000	*1	01 - 6120DA	- 1849	B-108	B-124	B-143	
630	64.2	9810	1000	*1	630	64.2	9810	1000	*1	01 - 6125DA	- 1849	B-108	B-124	B-143			
0.702	45.0	4.59	1770	180	*1	0.847	45.0	4.59	1770	180	*1	01 - 6070DA	- 2065	B-108	B-124	B-143	
	57.4	5.85	1580	161	*1		57.4	5.85	1580	161	*1	01 - 6075DA	- 2065	B-108	B-124	B-143	
	146	14.9	3300	336	*1		146	14.9	3300	336	*1	01 - 6090DA	- 2065	B-108	B-124	B-143	
	250	25.5	5400	550	*1		250	25.5	5400	550	*1	01 - 6100DA	- 2065	B-108	B-124	B-143	
	296	30.2	5090	519	*1		296	30.2	5090	519	*1	01 - 6105DA	- 2065	B-108	B-124	B-143	
	525	53.5	9810	1000	*1		525	53.5	9810	1000	*1	01 - 6120DA	- 2065	B-108	B-124	B-143	
630	64.2	9810	1000	*1	630	64.2	9810	1000	*1	01 - 6125DA	- 2065	B-108	B-124	B-143			
0.572	45.0	4.59	1770	180	*1	0.690	45.0	4.59	1770	180	*1	01 - 6070DA	- 2537	B-108	B-124	B-143	
	57.4	5.85	1580	161	*1		57.4	5.85	1580	161	*1	01 - 6075DA	- 2537	B-108	B-124	B-143	
	146	14.9	3300	336	*1		146	14.9	3300	336	*1	01 - 6090DA	- 2537	B-108	B-124	B-143	
	250	25.5	5400	550	*1		250	25.5	5400	550	*1	01 - 6100DA	- 2537	B-108	B-124	B-143	
	296	30.2	5090	519	*1		296	30.2	5090	519	*1	01 - 6105DA	- 2537	B-108	B-124	B-143	
	525	53.5	9810	1000	*1		525	53.5	9810	1000	*1	01 - 6120DA	- 2537	B-108	B-124	B-143	
630	64.2	9810	1000	*1	630	64.2	9810	1000	*1	01 - 6125DA	- 2537	B-108	B-124	B-143			

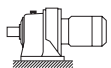
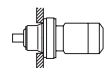
- "*2" indicate models manufactured with reducer and motor separately mounted on a common baseplate (horizontal shaft direction) or on an adaptor (vertical shaft direction). Consult us for details, including dimensions.
- Allowable radial load (Pro) is the value at the midpoint of the slow speed shaft.
- "*3" indicate models with reduction ratios equal to nominal ratio. Refer to Table A-3 "6000SK Series (Actual Reduction Ratio)" on page A-4 for actual reduction ratio. Indicated reduction ratio is the same as actual reduction ratio for other models.
- Maintain torque load during operation within "Output torque" in the table for models with "*" in the SF column. They cannot be operated with 100% motor rating.

Selection Tables Gearmotors

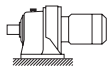
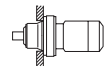
0.1 kW		n ₁ : Motor Speed														
		Hz		50Hz		60Hz										
		P	4	6	4	6										
n ₁	r/min	1450	980	1750	1165											
								 CHHM/CNHM  CHFM/CNFM  CVVM/CNVVM								
50Hz		60Hz				Nomenclature			Page of Dimension Sheet							
Output Speed n ₂	Output Torque Tout	Allowable Radial Load Pro		SF	Output Speed n ₂	Output Torque Tout	Allowable Radial Load Pro		SF	Input Capacity - Symbol	Frame Size	Reduction Ratio	CNHM	CNFM	CNVVM	
r/min	N·m	kgf·m	N	kgf	r/min	N·m	kgf·m	N	kgf				CHHM	CHFM	CVVM	
0.476	150	15.3	3310	338	*1	0.575	150	15.3	3310	338	*1	01 - 6090DA	- 3045	B-108	B-124	B-143
	192	19.6	3240	330	*1		192	19.6	3240	330	*1	01 - 6095DA	- 3045	B-108	B-124	B-143
	250	25.5	5400	550	*1		250	25.5	5400	550	*1	01 - 6100DA	- 3045	B-108	B-124	B-143
	300	30.6	4780	488	*1		300	30.6	4780	488	*1	01 - 6105DA	- 3045	B-108	B-124	B-143
	525	53.5	9780	997	*1		525	53.5	9780	997	*1	01 - 6120DA	- 3045	B-108	B-124	B-143
630	64.2	9560	974	*1	630	64.2	9560	974	*1	01 - 6125DA	- 3045	B-108	B-124	B-143		
0.417	146	14.9	3300	336	*1	0.503	146	14.9	3300	336	*1	01 - 6090DA	- 3481	B-108	B-124	B-143
	250	25.5	5400	550	*1		250	25.5	5400	550	*1	01 - 6100DA	- 3481	B-108	B-124	B-143
	296	30.2	5090	519	*1		296	30.2	5090	519	*1	01 - 6105DA	- 3481	B-108	B-124	B-143
	525	53.5	9810	1000	*1		525	53.5	9810	1000	*1	01 - 6120DA	- 3481	B-108	B-124	B-143
630	64.2	9810	1000	*1	630	64.2	9810	1000	*1	01 - 6125DA	- 3481	B-108	B-124	B-143		
0.327	150	15.3	3310	338	*1	0.394	150	15.3	3310	338	*1	01 - 6090DA	- 4437	B-108	B-124	B-143
	192	19.6	3240	330	*1		192	19.6	3240	330	*1	01 - 6095DA	- 4437	B-108	B-124	B-143
	250	25.5	5400	550	*1		250	25.5	5400	550	*1	01 - 6100DA	- 4437	B-108	B-124	B-143
	300	30.6	4780	488	*1		300	30.6	4780	488	*1	01 - 6105DA	- 4437	B-108	B-124	B-143
	525	53.5	9780	997	*1		525	53.5	9780	997	*1	01 - 6120DA	- 4437	B-108	B-124	B-143
630	64.2	9560	974	*1	630	64.2	9560	974	*1	01 - 6125DA	- 4437	B-108	B-124	B-143		
0.282	150	15.3	3310	338	*1	0.341	150	15.3	3310	338	*1	01 - 6090DA	- 5133	B-108	B-124	B-143
	192	19.6	3240	330	*1		192	19.6	3240	330	*1	01 - 6095DA	- 5133	B-108	B-124	B-143
	250	25.5	5400	550	*1		250	25.5	5400	550	*1	01 - 6100DA	- 5133	B-108	B-124	B-143
	300	30.6	4780	488	*1		300	30.6	4780	488	*1	01 - 6105DA	- 5133	B-108	B-124	B-143
	525	53.5	9780	997	*1		525	53.5	9780	997	*1	01 - 6120DA	- 5133	B-108	B-124	B-143
630	64.2	9560	974	*1	630	64.2	9560	974	*1	01 - 6125DA	- 5133	B-108	B-124	B-143		
0.235	525	53.5	9780	997	*1	0.283	525	53.5	9780	997	*1	01 - 6120DB	- 6177	B-108	B-124	B-143
	630	64.2	9560	974	*1		630	64.2	9560	974	*1	01 - 6125DB	- 6177	B-108	B-124	B-143
0.192	525	53.5	9780	997	*1	0.231	525	53.5	9780	997	*1	01 - 6120DB	- 7569	B-108	B-124	B-143
	630	64.2	9560	974	*1		630	64.2	9560	974	*1	01 - 6125DB	- 7569	B-108	B-124	B-143

0.2 kW		n ₁ : Motor Speed														
		Hz		50Hz		60Hz										
		P	4	6	4	6										
n ₁	r/min	1450	980	1750	1165											
								 CHHM/CNHM  CHFM/CNFM  CVVM/CNVVM								
50Hz		60Hz				Nomenclature			Page of Dimension Sheet							
Output Speed n ₂	Output Torque Tout	Allowable Radial Load Pro		SF	Output Speed n ₂	Output Torque Tout	Allowable Radial Load Pro		SF	Input Capacity - Symbol	Frame Size	Reduction Ratio	CNHM	CNFM	CNVVM	
r/min	N·m	kgf·m	N	kgf	r/min	N·m	kgf·m	N	kgf				CHHM	CHFM	CVVM	
242	7.51	0.765	798	81.4	1.00	292	6.22	0.634	751	76.6	1.00	02 - 6060	- 6	B-100	B-116	B-135
			798	81.4	1.43				751	76.6	1.43	02 - 6065	- 6	B-100	B-116	B-135
			1390	142	1.74				1310	134	1.74	02 - 6070	- 6	B-100	B-116	B-135
			1390	142	2.04				1310	134	2.04	02 - 6075	- 6	B-100	B-116	B-135
			1930	197	2.96				1820	185	2.96	02 - 6080	- 6	B-100	B-116	B-135
181	10.0	1.02	912	93.0	1.00	219	8.29	0.846	859	87.5	1.00	02 - 6060	- 8	B-100	B-116	B-135
			912	93	1.43				859	88	1.43	02 - 6065	- 8	B-100	B-116	B-135
			1540	157	1.74				1450	148	1.74	02 - 6070	- 8	B-100	B-116	B-135
			1540	157	2.04				1450	148	2.04	02 - 6075	- 8	B-100	B-116	B-135
			2100	214	2.96				1970	201	2.96	02 - 6080	- 8	B-100	B-116	B-135

1. Combinations in **bold** are the recommended models for operations for 10 hours/day with uniform load (service factor is about 1.0 for motor rating at 50Hz).
2. Motor slippage may affect n₁ and n₂. Refer to technical data for details.
3. CNHM, CHHM, CNFM, CHFM, CNVM, and CVVM indicate types. Refer to page B-10 for details.
4. Lubrication method is different for each model. Refer to "Lubrication" section in page F-4~F-5 for details.
5. "6" at the end of "input capacity symbol" indicates models with 6P motor. Other models come with 4P motor.

Selection Tables Gearmotors

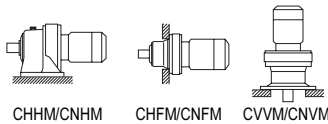

0.2 kW	Hz		50Hz		60Hz	
	P		4	6	4	6
	n ₁	r/min	1450	980	1750	1165

n₁: Motor Speed

50Hz					60Hz					Nomenclature			Page of Dimension Sheet												
Output Speed n ₂ r/min	Output Torque T _{out}		Allowable Radial Load Pro		SF	Output Speed n ₂ r/min	Output Torque T _{out}		Allowable Radial Load Pro		Input Capacity Symbol	Frame Size	Reduction Ratio	CNHM	CNFM	CNVM									
	N·m	kgf·m	N	kgf			N·m	kgf·m	N	kgf							CHHM	CHFM	CVVM						
132	13.8	1.40	1180	120	1.00	159	11.4	1.16	1170	119	1.00	02 -	6060	-	11	B-100	B-116	B-135							
			1180	120	1.43				1170	119	1.43								02 -	6065	-	11	B-100	B-116	B-135
			1730	176	1.74				1630	166	1.74								02 -	6070	-	11	B-100	B-116	B-135
			1730	176	2.04				1630	166	2.04								02 -	6075	-	11	B-100	B-116	B-135
			2320	236	2.96				2180	222	2.96								02 -	6080	-	11	B-100	B-116	B-135
112	16.3	1.66	1180	120	1.00	135	13.5	1.37	1180	120	1.00	02 -	6060	-	13	B-100	B-116	B-135							
			1180	120	1.43				1180	120	1.43								02 -	6065	-	13	B-100	B-116	B-135
			1770	180	1.74				1720	175	1.74								02 -	6070	-	13	B-100	B-116	B-135
			1770	180	2.04				1720	175	2.04								02 -	6075	-	13	B-100	B-116	B-135
			2500	254	2.96				2350	239	2.96								02 -	6080	-	13	B-100	B-116	B-135
96.7	18.8	1.91	1180	120	1.00	117	15.6	1.59	1180	120	1.00	02 -	6060	-	15	B-100	B-116	B-135							
			1180	120	1.43				1180	120	1.43								02 -	6065	-	15	B-100	B-116	B-135
			1770	180	1.74				1730	176	1.74								02 -	6070	-	15	B-100	B-116	B-135
			1770	180	2.04				1730	176	2.04								02 -	6075	-	15	B-100	B-116	B-135
			2560	261	2.96				2420	247	2.96								02 -	6080	-	15	B-100	B-116	B-135
85.3	21.3	2.17	1180	120	1.00	103	17.6	1.80	1180	120	1.00	02 -	6060	-	17	B-100	B-116	B-135							
			1180	120	1.41				1180	120	1.43								02 -	6065	-	17	B-100	B-116	B-135
			1770	180	1.74				1770	180	1.74								02 -	6070	-	17	B-100	B-116	B-135
			1770	180	2.04				1770	180	2.04								02 -	6075	-	17	B-100	B-116	B-135
			2560	261	2.96				2540	259	2.96								02 -	6080	-	17	B-100	B-116	B-135
69.0	26.3	2.68	1180	120	1.14	83.3	21.8	2.22	1180	120	1.17	02 -	6065	-	21	B-100	B-116	B-135							
			1770	180	1.60				1770	180	1.60								02 -	6070	-	21	B-100	B-116	B-135
			1770	180	2.04				1770	180	2.04								02 -	6075	-	21	B-100	B-116	B-135
			2560	261	2.39				2480	253	2.39								02 -	6080	-	21	B-100	B-116	B-135
			2560	261	2.75				2480	253	2.75								02 -	6085	-	21	B-100	B-116	B-135
58.0	31.3	3.19	1180	120	0.83	70.0	25.9	2.64	1180	120	0.83	02 -	6065	-	25	B-100	B-116	B-135							
			1770	180	1.15				1770	180	1.15								02 -	6070	-	25	B-100	B-116	B-135
			1770	180	1.47				1770	180	1.47								02 -	6075	-	25	B-100	B-116	B-135
			2560	261	1.70				2550	260	1.70								02 -	6080	-	25	B-100	B-116	B-135
			2560	261	2.38				2550	260	2.38								02 -	6085	-	25	B-100	B-116	B-135
50.0	36.3	3.70	1180	120	0.83	60.3	30.1	3.07	1180	120	0.83	02 -	6065	-	29	B-100	B-116	B-135							
			1770	180	1.13				1770	180	1.13								02 -	6070	-	29	B-100	B-116	B-135
			1770	180	1.43				1770	180	1.43								02 -	6075	-	29	B-100	B-116	B-135
			2560	261	1.70				2560	261	1.70								02 -	6080	-	29	B-100	B-116	B-135
			2560	261	2.34				2560	261	2.34								02 -	6085	-	29	B-100	B-116	B-135
41.4	43.8	4.46	1770	180	1.03	50.0	36.3	3.70	1770	180	1.06	02 -	6070	-	35	B-100	B-116	B-135							
			1770	180	1.36				1770	180	1.40								02 -	6075	-	35	B-100	B-116	B-135
			2560	261	1.45				2560	261	1.65								02 -	6080	-	35	B-100	B-116	B-135
			2560	261	1.64				2560	261	1.86								02 -	6085	-	35	B-100	B-116	B-135
			3340	340	3.06				3340	340	3.06								02 -	6090	-	35	B-100	B-116	B-135
33.7	53.8	5.49	1770	180	1.12	40.7	44.6	4.54	1770	180	1.13	02 -	6075	-	43	B-100	B-116	B-135							
			2560	261	1.25				2560	261	1.25								02 -	6080	-	43	B-100	B-116	B-135
			2560	261	1.47				2560	261	1.47								02 -	6085	-	43	B-100	B-116	B-135
			3340	340	2.18				3340	340	2.18								02 -	6090	-	43	B-100	B-116	B-135
			2560	261	1.21				2560	261	1.21								02 -	6085	-	51	B-100	B-116	B-135
28.4	63.8	6.51	3340	340	1.66	34.3	52.9	5.39	3340	340	1.66	02 -	6090	-	51	B-100	B-116	B-135							
			3340	340	2.04				3340	340	2.11								02 -	6095	-	51	B-100	B-116	B-135
			5400	550	2.80				5400	550	2.80								02 -	6100	-	51	B-101	B-117	B-136
			2560	261	1.17				2560	261	1.17								02 -	6085	-	59	B-100	B-116	B-135
			3340	340	1.55				3340	340	1.55								02 -	6090	-	59	B-100	B-116	B-135
24.6	73.8	7.53	3340	340	1.68	29.7	61.2	6.24	3340	340	1.87	02 -	6095	-	59	B-100	B-116	B-135							
			5400	550	2.58				5400	550	2.58								02 -	6100	-	59	B-101	B-117	B-136
			2380	243	0.83				2510	256	0.94								02 -	6085	-	71	B-100	B-116	B-135
			3340	340	1.26				3340	340	1.26								02 -	6090	-	71	B-100	B-116	B-135
			3340	340	1.39				3340	340	1.51								02 -	6095	-	71	B-100	B-116	B-135
20.4	88.8	9.06	5400	550	2.18	24.6	73.6	7.50	5400	550	2.18	02 -	6100	-	71	B-101	B-117	B-136							
			5400	550	2.53				5400	550	2.81								02 -	6105	-	71	B-101	B-117	B-136

- "*2" indicate models manufactured with reducer and motor separately mounted on a common baseplate (horizontal shaft direction) or on an adaptor (vertical shaft direction). Consult us for details, including dimensions.
- Allowable radial load (Pro) is the value at the midpoint of the slow speed shaft.
- "*3" indicate models with reduction ratios equal to nominal ratio. Refer to Table A-3 "6000SK Series (Actual Reduction Ratio)" on page A-4 for actual reduction ratio. Indicated reduction ratio is the same as actual reduction ratio for other models.
- Maintain torque load during operation within "Output torque" in the table for models with "*" in the SF column. They cannot be operated with 100% motor rating.

GEARMOTORS
Selection Tables
0.2 kW

Selection Tables Gearmotors

0.2 kW		n ₁ : Motor Speed					
		Hz		50Hz		60Hz	
		P	4	6	4	6	
n ₁ r/min		1450	980	1750	1165		

50Hz						60Hz						Nomenclature			Page of Dimension Sheet										
Output Speed n ₂ r/min	Output Torque Tout N·m kgf·m		Allowable Radial Load Pro N kgf		SF	Output Speed n ₂ r/min	Output Torque Tout N·m kgf·m		Allowable Radial Load Pro N kgf		SF	Input Capacity Symbol	Frame Size	Reduction Ratio	CNHM	CNFM	CNVM								
16.7	109	11.1	3340	340	1.06	20.1	90.2	9.20	3340	340	1.06	02 -	6090	- 87	B-100	B-116	B-135								
			3340	340	1.32				3340	340	1.51				02 -	6095	- 87	B-100	B-116	B-135					
			5400	550	2.17				5400	550	2.17				02 -	6100	- 87	B-101	B-117	B-136					
			5400	550	2.52				5400	550	2.83				02 -	6105	- 87	B-101	B-117	B-136					
13.9	123	12.6	60.0	6.12	1770	180	*1	16.8	102	10.4	*1	02 -	6075DA	- 104	B-108	B-124	B-143								
			3340	340	1.22	3340	340								1.47	02 -	6090DA	- 104	B-108	B-124	B-143				
			3340	340	1.47	3340	340								1.77	02 -	6095DA	- 104	B-108	B-124	B-143				
			5400	550	2.03	5400	550								2.15	02 -	6100DA	- 104	B-108	B-124	B-143				
12.2	149.0	15.2	5400	550	1.05	14.7	123	12.6	5400	550	1.05	02 -	6100	- 119	B-101	B-117	B-136								
			5400	550	1.43				5400	550	1.43				02 -	6105	- 119	B-101	B-117	B-136					
			3340	340	1.05				3340	340	1.26				02 -	6090DA	- 121	B-108	B-124	B-143					
			3340	340	1.12				3340	340	1.35				02 -	6095DA	- 121	B-108	B-124	B-143					
12.0	143	14.6	5400	550	1.74	14.5	119	12.1	5400	550	2.10	02 -	6100DA	- 121	B-108	B-124	B-143								
			5400	550	2.14				5400	550	2.15				02 -	6105DA	- 121	B-108	B-124	B-143					
			9810	1000	2.15				9810	1000	2.15				02 -	6120DA	- 121	B-108	B-124	B-143					
			3340	340	1.08				3340	340	1.30				02 -	6095DA	- 143	B-108	B-124	B-143					
10.1	170	17.3	5400	550	1.47	12.2	140	14.3	5400	550	1.78	02 -	6100DA	- 143	B-108	B-124	B-143								
			5400	550	1.77				5400	550	2.14				02 -	6105DA	- 143	B-108	B-124	B-143					
			5400	550	1.77				5400	550	2.14				02 -	6105DA	- 143	B-108	B-124	B-143					
			9810	1000	2.15				9810	1000	2.15				02 -	6120DA	- 143	B-108	B-124	B-143					
8.79	196	19.9	150	15.3	3340	340	*1	10.6	162	16.5	*1	02 -	6090DA	- 165	B-108	B-124	B-143								
			3340	340	1.02	3340	340								1.23	02 -	6095DA	- 165	B-108	B-124	B-143				
			5400	550	1.28	5400	550								1.54	02 -	6100DA	- 165	B-108	B-124	B-143				
			5400	550	1.53	5400	550								1.85	02 -	6105DA	- 165	B-108	B-124	B-143				
7.44	231	23.6	9810	1000	2.15	8.97	192	19.5	9810	1000	2.15	02 -	6120DA	- 195	B-108	B-124	B-143								
			9810	1000	2.27				9810	1000	2.74				02 -	6120DB	- 195	B-108	B-124	B-143					
			9810	1000	2.73				9810	1000	3.29				02 -	6125DB	- 195	B-108	B-124	B-143					
			3340	340	1.08				3340	340	1.30				02 -	6095DA	- 143	B-108	B-124	B-143					
6.28	274	27.9	150	15.3	3340	340	*1	7.58	227	23.1	*1	02 -	6090DA	- 231	B-108	B-124	B-143								
			200	20.4	3340	340	*1								200	20.4	3340	340	*1	02 -	6095DA	- 231	B-108	B-124	B-143
			5400	550	1.10	5400	550								1.32	02 -	6105DA	- 231	B-108	B-124	B-143				
			9810	1000	1.91	9810	1000								2.15	02 -	6120DA	- 231	B-108	B-124	B-143				
5.31	324	33.0	9810	1000	1.91	6.41	268	27.3	9810	1000	2.30	02 -	6120DB	- 231	B-108	B-124	B-143								
			9810	1000	2.15				9810	1000	2.15				02 -	6125DA	- 231	B-108	B-124	B-143					
			9810	1000	2.30				9810	1000	2.78				02 -	6125DB	- 231	B-108	B-124	B-143					
			14700	1500	2.85				14700	1500	3.44				02 -	6130DB	- 231	B-109	B-125	B-143					
5.31	324	33.0	150	15.3	3340	340	*1	6.41	268	27.3	*1	02 -	6090DA	- 273	B-108	B-124	B-143								
			200	20.4	3340	340	*1								200	20.4	3340	340	*1	02 -	6095DA	- 273	B-108	B-124	B-143
			250	25.5	5400	550	*1								250	25.5	5400	550	*1	02 -	6100DA	- 273	B-108	B-124	B-143
			5400	550	0.93	5400	550								1.12	02 -	6105DA	- 273	B-108	B-124	B-143				
5.31	324	33.0	9810	1000	1.61	6.41	268	27.3	9810	1000	1.95	02 -	6120DA	- 273	B-108	B-124	B-143								
			9810	1000	1.95				9810	1000	2.15				02 -	6125DA	- 273	B-108	B-124	B-143					
			9810	1000	1.95				9810	1000	2.35				02 -	6125DB	- 273	B-108	B-124	B-143					
			14700	1500	2.15				14700	1500	2.15				02 -	6130DA	- 273	B-109	B-125	B-144					
5.31	324	33.0	14700	1500	2.41	6.41	268	27.3	14700	1500	2.91	02 -	6130DB	- 273	B-109	B-125	B-143								
			14700	1500	2.41				14700	1500	2.91				02 -	6130DB	- 273	B-109	B-125	B-143					
			14700	1500	2.90				14700	1500	3.51				02 -	6135DB	- 273	B-109	B-125	B-144					

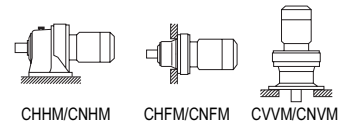

GEARMOTORS
Selection Tables
0.2 kW

1. Combinations in **bold** are the recommended models for operations for 10 hours/day with uniform load (service factor is about 1.0 for motor rating at 50Hz).
2. Motor slippage may affect n₁ and n₂. Refer to technical data for details.
3. CNHM, CHHM, CNFM, CHFM, CNVM, and CVVM indicate types. Refer to page B-10 for details.
4. Lubrication method is different for each model. Refer to "Lubrication" section in page F-4~F-5 for details.
5. "6" at the end of "input capacity symbol" indicates models with 6P motor. Other models come with 4P motor.

Selection Tables Gearmotors

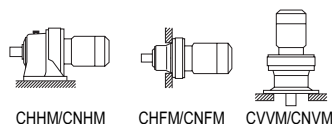

n₁: Motor Speed

0.2 kW	Hz		50Hz		60Hz	
	P		4	6	4	6
	n ₁	r/min	1450	980	1750	1165

50Hz					60Hz					Nomenclature			Page of Dimension Sheet					
Output Speed n ₂ r/min	Output Torque Tout		Allowable Radial Load Pro		SF	Output Speed n ₂ r/min	Output Torque Tout		Allowable Radial Load Pro		Input Capacity - Symbol	Frame Size	Reduction Ratio	CNHM	CNFM	CNVM		
	N·m	kgf·m	N	kgf			N·m	kgf·m	N	kgf							CHHM	CHFM
4.55	200	20.4	3200	326	*1	5.49	200	20.4	3200	326	*1	02 - 6095DA	- 319	B-108	B-124	B-143		
	250	25.5	5400	550	*1		250	25.5	5400	550	*1	02 - 6100DA	- 319	B-108	B-124	B-143		
	300	30.6	5400	550	*1		300	30.6	5400	550	*1	02 - 6105DA	- 319	B-108	B-124	B-143		
	378	38.6	9810	1000	1.38		9810	1000	1.66	02 - 6120DA	- 319	B-108	B-124	B-143				
			9810	1000	1.67		9810	1000	2.01	02 - 6125DA	- 319	B-108	B-124	B-143				
			14700	1500	2.06		14700	1500	2.15	02 - 6130DA	- 319	B-109	B-125	B-144				
			14700	1500	2.06		14700	1500	2.49	02 - 6130DB	- 319	B-109	B-125	B-143				
	3.85	200	20.4	3200	326		*1	4.64	200	20.4	3200	326	*1	02 - 6095DA	- 377	B-108	B-124	B-143
		250	25.5	5400	550		*1		250	25.5	5400	550	*1	02 - 6100DA	- 377	B-108	B-124	B-143
		300	30.6	5400	550		*1		300	30.6	5400	550	*1	02 - 6105DA	- 377	B-108	B-124	B-143
447		45.6	9810	1000	1.16	9810	1000		1.40	02 - 6120DA	- 377	B-108	B-124	B-143				
			9810	1000	1.41	9810	1000		1.70	02 - 6125DA	- 377	B-108	B-124	B-143				
			14700	1500	1.75	14700	1500		2.11	02 - 6130DA	- 377	B-109	B-125	B-144				
			14700	1500	2.10	14700	1500		2.15	02 - 6135DA	- 377	B-109	B-125	B-144				
3.07		250	25.5	5400	550	*1	3.70		250	25.5	5400	550	*1	02 - 6135DB	- 377	B-109	B-125	B-144
		300	30.6	5400	550	*1			300	30.6	5400	550	*1	02 - 6140DA	- 377	B-109	B-125	B-144
		561	57.2	9810	1000	1.12			9810	1000	1.36	02 - 6140DB	- 377	B-109	B-125	B-144		
	14700			1500	1.39	14700		1500	2.02	02 - 6145DA	- 377	B-109	B-125	B-144				
	14700			1500	1.68	14700		1500	2.15	02 - 6145DB	- 377	B-109	B-125	B-144				
	16000			1630	2.15	16000		1630	2.64	02 - 6140DA	- 473	B-108	B-124	B-143				
	2.59	250	25.5	5400	550	*1		3.13	250	25.5	5400	550	*1	02 - 6140DB	- 473	B-109	B-125	B-144
		300	30.6	5400	550	*1			300	30.6	5400	550	*1	02 - 6145DB	- 473	B-109	B-125	B-144
		663	67.6	9810	1000	0.95			9810	1000	1.15	02 - 6105DA	- 559	B-108	B-124	B-143		
				14700	1500	1.18			14700	1500	1.42	02 - 6125DA	- 559	B-108	B-124	B-143		
14700				1500	1.42	14700	1500		1.71	02 - 6130DA	- 559	B-109	B-125	B-144				
16000				1630	1.85	16000	1630		2.15	02 - 6135DA	- 559	B-109	B-125	B-144				
2.23		300	30.6	5400	550	*1	2.70		300	30.6	5400	550	*1	02 - 6140DA	- 559	B-109	B-125	B-144
		525	53.5	9810	1000	*1			525	53.5	9810	1000	*1	02 - 6140DB	- 559	B-109	B-125	B-144
		769	78.4	9810	1000	0.82			9810	1000	0.98	02 - 6145DA	- 559	B-109	B-125	B-144		
				14700	1500	1.19			14700	1500	1.43	02 - 6145DB	- 559	B-109	B-125	B-144		
	14700			1500	1.36	14700		1500	1.65	02 - 6105DA	- 649	B-108	B-124	B-143				
	16000			1630	1.59	16000		1630	1.92	02 - 6125DA	- 649	B-108	B-124	B-143				
	1.98	525	53.5	9810	1000	*1		2.39	525	53.5	9810	1000	*1	02 - 6130DA	- 649	B-109	B-125	B-144
		630	64.2	9810	1000	*1			630	64.2	9810	1000	*1	02 - 6135DA	- 649	B-109	B-125	B-144
		867	88.3	14700	1500	1.08			14700	1500	1.31	02 - 6140DA	- 649	B-109	B-125	B-144		
				16000	1630	1.41			16000	1630	1.71	02 - 6145DA	- 649	B-109	B-125	B-144		
16000				1630	1.58	16000	1630		1.91	02 - 6140DA	- 731	B-108	B-124	B-143				
16000				1630	1.58	16000	1630		1.91	02 - 6145DA	- 731	B-108	B-124	B-143				
1.72		520	53.0	9810	1000	*1	2.08		520	53.0	9810	1000	*1	02 - 6120DA	- 731	B-108	B-124	B-143
		630	64.2	9810	1000	*1			630	64.2	9810	1000	*1	02 - 6125DA	- 731	B-108	B-124	B-143
		780	79.5	14700	1500	*1			780	79.5	14700	1500	*1	02 - 6130DA	- 841	B-109	B-125	B-144
		997	102	14700	1500	0.94			14700	1500	1.14	02 - 6135DA	- 841	B-109	B-125	B-144		
	16000			1630	1.23	16000		1630	1.48	02 - 6140DA	- 841	B-109	B-125	B-144				
	16000	1630	1.37	16000	1630	1.51		02 - 6145DA	- 841	B-109	B-125	B-144						

- "*2" indicate models manufactured with reducer and motor separately mounted on a common baseplate (horizontal shaft direction) or on an adaptor (vertical shaft direction). Consult us for details, including dimensions.
- Allowable radial load (Pro) is the value at the midpoint of the slow speed shaft.
- "*3" indicate models with reduction ratios equal to nominal ratio. Refer to Table A-3 "6000SK Series (Actual Reduction Ratio)" on page A-4 for actual reduction ratio. Indicated reduction ratio is the same as actual reduction ratio for other models.
- Maintain torque load during operation within "Output torque" in the table for models with "*" in the SF column. They cannot be operated with 100% motor rating.

Selection Tables Gearmotors

0.2 kW		n ₁ : Motor Speed					
		Hz		50Hz		60Hz	
		P	4	6	4	6	
n ₁	r/min	1450	980	1750	1165		

		50Hz				60Hz				Nomenclature			Page of Dimension Sheet			
Output Speed n ₂ r/min	Output Torque T _{out}		Allowable Radial Load Pro		SF	Output Speed n ₂ r/min	Output Torque T _{out}		Allowable Radial Load Pro		Input Capacity Symbol	Frame Size	Reduction Ratio	CNHM	CNFM	CNVM
	N·m	kgf·m	N	kgf			N·m	kgf·m	N	kgf						
1.45	525	53.5	9810	1000	*1	1.74	525	53.5	9810	1000	*1	02 - 6120DA	- 1003	B-108	B-124	B-143
	630	64.2	9810	1000	*1		630	64.2	9810	1000	*1	02 - 6125DA	- 1003	B-108	B-124	B-143
	912	93.0	14700	1500	*1		912	93.0	14700	1500	*1	02 - 6130DA	- 1003	B-109	B-125	B-144
			14700	1500	0.88				14700	1500	1.07	02 - 6135DA	- 1003	B-109	B-125	B-144
	1190	121	16000	1630	1.03		985	100	16000	1630	1.24	02 - 6140DA	- 1003	B-109	B-125	B-144
		16000	1630	1.15			16000	1630	1.39	02 - 6145DA	- 1003	B-109	B-125	B-144		
1.16	630	64.2	9810	1000	*1	1.40	630	64.2	9810	1000	*1	02 - 6125DA	- 1247	B-108	B-124	B-143
	780	79.5	14700	1500	*1		780	79.5	14700	1500	*1	02 - 6130DA	- 1247	B-109	B-125	B-144
	940	95.8	14700	1500	*1		940	95.8	14700	1500	*1	02 - 6135DA	- 1247	B-109	B-125	B-144
	1230	125	16000	1630	*1		1230	125	16000	1630	*1	02 - 6140DA	- 1247	B-109	B-125	B-144
	1480	151	15200	1540	0.93		1220	125	16000	1630	1.12	02 - 6145DA	- 1247	B-109	B-125	B-144
0.980	848	86.5	14700	1500	*1	1.18	848	86.5	14700	1500	*1	02 - 6130DA	- 1479	B-109	B-125	B-144
	979	99.8	14700	1500	*1		979	99.8	14700	1500	*1	02 - 6135DA	- 1479	B-109	B-125	B-144
	1230	125	16000	1630	*1		1230	125	16000	1630	*1	02 - 6140DA	- 1479	B-109	B-125	B-144
	1250	127	16000	1630	*1		1250	127	16000	1630	*1	02 - 6145DA	- 1479	B-109	B-125	B-144
	780	79.5	14700	1500	*1		780	79.5	14700	1500	*1	02 - 6130DA	- 1849	B-109	B-125	B-144
940	95.8	14700	1500	*1	940	95.8	14700	1500	*1	02 - 6135DA	- 1849	B-109	B-125	B-144		
1230	125	16000	1630	*1	1230	125	16000	1630	*1	02 - 6140DA	- 1849	B-109	B-125	B-144		
1370	140	15700	1600	*1	1370	140	15700	1600	*1	02 - 6145DA	- 1849	B-109	B-125	B-144		
1740	177	22100	2250	*1	1740	177	22100	2250	*1	02 - 6160DA	- 1849	B-110	B-126	B-145		
0.702	912	93.0	14700	1500	*1	0.847	912	93.0	14700	1500	*1	02 - 6130DA	- 2065	B-109	B-125	B-144
	1050	107	14700	1500	*1		1050	107	14700	1500	*1	02 - 6135DA	- 2065	B-109	B-125	B-144
	1230	125	16000	1630	*1		1230	125	16000	1630	*1	02 - 6140DA	- 2065	B-109	B-125	B-144
	1370	140	16000	1630	*1		1370	140	16000	1630	*1	02 - 6145DA	- 2065	B-109	B-125	B-144
	1760	179	22100	2250	*1		1760	179	22100	2250	*1	02 - 6160DA	- 2065	B-110	B-126	B-145
	2450	250	22100	2250	0.86		2030	207	22100	2250	1.04	02 - 6165DA	- 2065	B-110	B-126	B-145
0.572	912	93.0	14700	1500	*1	0.690	912	93.0	14700	1500	*1	02 - 6130DA	- 2537	B-109	B-125	B-144
	1050	107	14700	1500	*1		1050	107	14700	1500	*1	02 - 6135DA	- 2537	B-109	B-125	B-144
	1230	125	16000	1630	*1		1230	125	16000	1630	*1	02 - 6140DA	- 2537	B-109	B-125	B-144
	1370	140	16000	1630	*1		1370	140	16000	1630	*1	02 - 6145DA	- 2537	B-109	B-125	B-144
	1760	179	22100	2250	*1		1760	179	22100	2250	*1	02 - 6160DA	- 2537	B-110	B-126	B-145
	2100	214	22100	2250	*1		2100	214	22100	2250	*1	02 - 6165DA	- 2537	B-110	B-126	B-145
	848	86.5	14700	1500	*1		848	86.5	14700	1500	*1	02 - 6130DA	- 3045	B-109	B-125	B-144
979	99.8	14700	1500	*1	979	99.8	14700	1500	*1	02 - 6135DA	- 3045	B-109	B-125	B-144		
1230	125	16000	1630	*1	1230	125	16000	1630	*1	02 - 6140DA	- 3045	B-109	B-125	B-144		
1250	127	16000	1630	*1	1250	127	16000	1630	*1	02 - 6145DA	- 3045	B-109	B-125	B-144		
1760	179	22100	2250	*1	1760	179	22100	2250	*1	02 - 6160DA	- 3045	B-110	B-126	B-145		
2050	209	21800	2220	*1	2050	209	21800	2220	*1	02 - 6165DA	- 3045	B-110	B-126	B-145		
2530	258	29500	3010	*1	2530	258	29500	3010	*1	02 - 6170DA	- 3045	B-110	B-126	B-145		
3610	368	29500	3010	0.87	2990	305	29500	3010	1.05	02 - 6175DA	- 3045	B-110	B-126	B-145		
0.417	912	93.0	14700	1500	*1	0.503	912	93.0	14700	1500	*1	02 - 6130DA	- 3481	B-109	B-125	B-144
	1050	107	14700	1500	*1		1050	107	14700	1500	*1	02 - 6135DA	- 3481	B-109	B-125	B-144
	1230	125	16000	1630	*1		1230	125	16000	1630	*1	02 - 6140DA	- 3481	B-109	B-125	B-144
	1370	140	16000	1630	*1		1370	140	16000	1630	*1	02 - 6145DA	- 3481	B-109	B-125	B-144
	1760	179	22100	2250	*1		1760	179	22100	2250	*1	02 - 6160DA	- 3481	B-110	B-126	B-145
	2100	214	22100	2250	*1		2100	214	22100	2250	*1	02 - 6165DA	- 3481	B-110	B-126	B-145
	2530	258	29500	3010	*1		2530	258	29500	3010	*1	02 - 6170DA	- 3481	B-110	B-126	B-145
	3150	321	29500	3010	*1		3150	321	29500	3010	*1	02 - 6175DA	- 3481	B-110	B-126	B-145

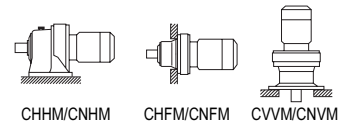

GEARMOTORS

Selection Tables
0.2 kW

1. Combinations in **bold** are the recommended models for operations for 10 hours/day with uniform load (service factor is about 1.0 for motor rating at 50Hz).
2. Motor slippage may affect n₁ and n₂. Refer to technical data for details.
3. CNHM, CHHM, CNFM, CHFM, CNVM, and CVVM indicate types. Refer to page B-10 for details.
4. Lubrication method is different for each model. Refer to "Lubrication" section in page F-4~F-5 for details.
5. "6" at the end of "input capacity symbol" indicates models with 6P motor. Other models come with 4P motor.

Selection Tables Gearmotors

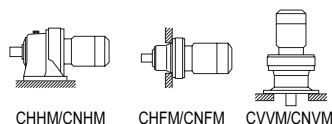

0.2 kW	Hz		50Hz		60Hz	
	P		4	6	4	6
	n ₁	r/min	1450	980	1750	1165

n: Motor Speed



50Hz					60Hz					Nomenclature			Page of Dimension Sheet			
Output Speed n ₂ r/min	Output Torque Tout		Allowable Radial Load Pro		SF	Output Speed n ₂ r/min	Output Torque Tout		Allowable Radial Load Pro		Input Capacity - Symbol	Frame Size	Reduction Ratio	CNHM	CNFM	CNVM
	N·m	kgf·m	N	kgf			N·m	kgf·m	N	kgf						
0.327	848	86.5	14700	1500	*1	0.394	848	86.5	14700	1500	*1	02 - 6130DA	- 4437	B-109	B-125	B-144
	979	99.8	14700	1500	*1		979	99.8	14700	1500	*1	02 - 6135DA	- 4437	B-109	B-125	B-144
	1230	125	16000	1630	*1		1230	125	16000	1630	*1	02 - 6140DA	- 4437	B-109	B-125	B-144
	1250	127	16000	1630	*1		1250	127	16000	1630	*1	02 - 6145DA	- 4437	B-109	B-125	B-144
	1760	179	22100	2250	*1		1760	179	22100	2250	*1	02 - 6160DA	- 4437	B-110	B-126	B-145
	2050	209	21800	2220	*1		2050	209	21800	2220	*1	02 - 6165DA	- 4437	B-110	B-126	B-145
	2530	258	29500	3010	*1		2530	258	29500	3010	*1	02 - 6170DA	- 4437	B-110	B-126	B-145
3150	321	29500	3010	*1	3150	321	29500	3010	*1	02 - 6175DA	- 4437	B-110	B-126	B-145		
0.282	848	86.5	14700	1500	*1	0.341	848	86.5	14700	1500	*1	02 - 6130DA	- 5133	B-109	B-125	B-144
	979	99.8	14700	1500	*1		979	99.8	14700	1500	*1	02 - 6135DA	- 5133	B-109	B-125	B-144
	1230	125	16000	1630	*1		1230	125	16000	1630	*1	02 - 6140DA	- 5133	B-109	B-125	B-144
	1250	127	16000	1630	*1		1250	127	16000	1630	*1	02 - 6145DA	- 5133	B-109	B-125	B-144
	1760	179	22100	2250	*1		1760	179	22100	2250	*1	02 - 6160DA	- 5133	B-110	B-126	B-145
	2050	209	21800	2220	*1		2050	209	21800	2220	*1	02 - 6165DA	- 5133	B-110	B-126	B-145
	2530	258	29500	3010	*1		2530	258	29500	3010	*1	02 - 6170DA	- 5133	B-110	B-126	B-145
3150	321	29500	3010	*1	3150	321	29500	3010	*1	02 - 6175DA	- 5133	B-110	B-126	B-145		
0.235	848	86.5	14700	1500	*1	0.283	848	86.5	14700	1500	*1	02 - 6130DB	- 6177	B-109	B-125	B-143
	979	99.8	14700	1500	*1		979	99.8	14700	1500	*1	02 - 6135DB	- 6177	B-109	B-125	B-144
	1230	125	16000	1630	*1		1230	125	16000	1630	*1	02 - 6140DB	- 6177	B-109	B-125	B-144
	1250	127	16000	1630	*1		1250	127	16000	1630	*1	02 - 6145DB	- 6177	B-109	B-125	B-144
	1760	179	22100	2250	*1		1760	179	22100	2250	*1	02 - 6160DA	- 6177	B-110	B-126	B-145
	2050	209	21800	2220	*1		2050	209	21800	2220	*1	02 - 6165DA	- 6177	B-110	B-126	B-145
	2530	258	29500	3010	*1		2530	258	29500	3010	*1	02 - 6170DA	- 6177	B-110	B-126	B-145
3150	321	29500	3010	*1	3150	321	29500	3010	*1	02 - 6175DA	- 6177	B-110	B-126	B-145		
0.192	848	86.5	14700	1500	*1	0.231	848	86.5	14700	1500	*1	02 - 6130DB	- 7569	B-109	B-125	B-143
	979	99.8	14700	1500	*1		979	99.8	14700	1500	*1	02 - 6135DB	- 7569	B-109	B-125	B-144
	1230	125	16000	1630	*1		1230	125	16000	1630	*1	02 - 6140DB	- 7569	B-109	B-125	B-144
	1250	127	16000	1630	*1		1250	127	16000	1630	*1	02 - 6145DB	- 7569	B-109	B-125	B-144
	1760	179	22100	2250	*1		1760	179	22100	2250	*1	02 - 6160DA	- 7569	B-110	B-126	B-145
	2050	209	21800	2220	*1		2050	209	21800	2220	*1	02 - 6165DA	- 7569	B-110	B-126	B-145
	2530	258	29500	3010	*1		2530	258	29500	3010	*1	02 - 6170DA	- 7569	B-110	B-126	B-145
3150	321	29500	3010	*1	3150	321	29500	3010	*1	02 - 6175DA	- 7569	B-110	B-126	B-145		

GEARMOTORS

Selection Tables
0.2 kW

- "*2" indicate models manufactured with reducer and motor separately mounted on a common baseplate (horizontal shaft direction) or on an adaptor (vertical shaft direction). Consult us for details, including dimensions.
- Allowable radial load (Pro) is the value at the midpoint of the slow speed shaft.
- "*3" indicate models with reduction ratios equal to nominal ratio. Refer to Table A-3 "6000SK Series (Actual Reduction Ratio)" on page A-4 for actual reduction ratio. Indicated reduction ratio is the same as actual reduction ratio for other models.
- Maintain torque load during operation within "Output torque" in the table for models with "*" in the SF column. They cannot be operated with 100% motor rating.

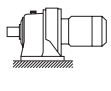
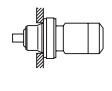
Selection Tables Gearmotors

0.25 kW		n ₁ : Motor Speed												
		Hz		50Hz		60Hz								
		P		4	6	4	6							
n ₁	r/min	1450	980	1750	1165									
		  					CHHM/CNHM		CHFM/CNFM		CVVM/CNVM			
50Hz			60Hz					Nomenclature			Page of Dimension Sheet			
Output Speed n ₂	Output Torque Tout	Allowable Radial Load Pro	SF	Output Speed n ₂	Output Torque Tout	Allowable Radial Load Pro	SF	Input Capacity Symbol	Frame Size	Reduction Ratio	CNHM	CNFM	CNVM	
r/min	N·m	kgf·m		r/min	N·m	kgf·m					CHHM	CHFM	CVVM	
242	9.39	0.957	795	81.1	1.14	292	7.78	0.793	03 -	6065	- 6	B-100	B-116	B-135
			1390	141	1.39							B-100	B-116	B-135
			1390	141	1.63							B-100	B-116	B-135
181	12.5	1.28	908	92.5	1.14	219	10.4	1.06	03 -	6065	- 8	B-100	B-116	B-135
			1530	156	1.39							B-100	B-116	B-135
			1530	156	1.63							B-100	B-116	B-135
132	17.2	1.75	1180	120	1.14	159	14.3	1.45	03 -	6075	- 11	B-100	B-116	B-135
			1720	175	1.39							B-100	B-116	B-135
			1720	175	1.63							B-100	B-116	B-135
112	20.3	2.07	1180	120	1.14	135	16.8	1.72	03 -	6065	- 13	B-100	B-116	B-135
			1770	180	1.39							B-100	B-116	B-135
			1770	180	1.63							B-100	B-116	B-135
96.7	23.5	2.39	1180	120	1.14	117	19.4	1.98	03 -	6065	- 15	B-100	B-116	B-135
			1770	180	1.39							B-100	B-116	B-135
			1770	180	1.63							B-100	B-116	B-135
85.3	26.6	2.71	1180	120	1.14	103	22.0	2.25	03 -	6065	- 17	B-100	B-116	B-135
			1770	180	1.39							B-100	B-116	B-135
			1770	180	1.63							B-100	B-116	B-135
69.0	32.8	3.35	1180	120	1.14	83.3	27.2	2.77	03 -	6075	- 21	B-100	B-116	B-135
			1770	180	1.63							B-100	B-116	B-135
			2560	261	2.37							B-100	B-116	B-135
58.0	39.1	3.99	1770	180	1.18	70.0	32.4	3.30	03 -	6075	- 25	B-100	B-116	B-135
			2560	261	1.36							B-100	B-116	B-135
			2560	261	1.90							B-100	B-116	B-135
50.0	45.4	4.62	1770	180	1.14	60.3	37.6	3.83	03 -	6075	- 29	B-100	B-116	B-135
			2560	261	1.36							B-100	B-116	B-135
			2560	261	1.87							B-100	B-116	B-135
41.4	54.7	5.58	1770	180	1.09	50.0	45.4	4.62	03 -	6075	- 35	B-100	B-116	B-135
			2560	261	1.16							B-100	B-116	B-135
			2560	261	1.31							B-100	B-116	B-135
33.7	67.3	6.86	1500	152	0.89	40.7	55.7	5.68	03 -	6075	- 43	B-100	B-116	B-135
			2560	261	1.00							B-100	B-116	B-135
			2560	261	1.18							B-100	B-116	B-135
28.4	79.8	8.13	3340	340	1.74	34.3	66.1	6.74	03 -	6090	- 43	B-100	B-116	B-135
			3340	340	2.41							B-100	B-116	B-135
			2490	253	0.96							B-100	B-116	B-135
24.6	92.3	9.41	3340	340	1.24	29.7	76.5	7.79	03 -	6095	- 51	B-100	B-116	B-135
			3340	340	1.34							B-100	B-116	B-135
			2390	244	0.94							B-100	B-116	B-135
			3340	340	1.24				03 -	6090	- 59	B-100	B-116	B-135
			3340	340	1.34				03 -	6095	- 59	B-100	B-116	B-135
			5400	550	2.06				03 -	6100	- 59	B-101	B-117	B-136
			5400	550	2.72				03 -	6105	- 59	B-101	B-117	B-136

1. Combinations in **bold** are the recommended models for operations for 10 hours/day with uniform load (service factor is about 1.0 for motor rating at 50Hz).
2. Motor slippage may affect n₁ and n₂. Refer to technical data for details.
3. CNHM, CHHM, CNFM, CHFM, CNVM, and CVVM indicate types. Refer to page B-10 for details.
4. Lubrication method is different for each model. Refer to "Lubrication" section in page F-4~F-5 for details.
5. "6" at the end of "input capacity symbol" indicates models with 6P motor. Other models come with 4P motor.

Selection Tables Gearmotors

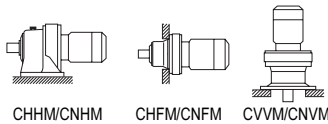

0.25 kW	Hz		50Hz		60Hz	
	P		4	6	4	6
	n ₁	r/min	1450	980	1750	1165

n: Motor Speed

50Hz						60Hz					Nomenclature			Page of Dimension Sheet									
Output Speed n ₂ r/min	Output Torque Tout		Allowable Radial Load Pro		SF	Output Speed n ₂ r/min	Output Torque Tout		Allowable Radial Load Pro		SF	Input Capacity Symbol	Frame Size	Reduction Ratio	CNHM	CNFM	CNVM						
	N·m	kgf·m	N	kgf			N·m	kgf·m	N	kgf								CHHM	CHFM	CVVM			
20.4	111	11.3	3340	340	1.01	24.6	92	9.4	3340	340	1.20	03	- 6090	- 71	B-100	B-116	B-135						
			3340	340	1.11				3340	340	1.20							03	- 6095	- 71	B-100	B-116	B-135
			5400	550	1.74				5400	550	1.74							03	- 6100	- 71	B-101	B-117	B-136
			5400	550	2.02				5400	550	2.24							03	- 6105	- 71	B-101	B-117	B-136
16.7	136	13.9	3340	340	1.05	20.1	113	11.5	3340	340	1.20	03	- 6095	- 87	B-100	B-116	B-135						
			5400	550	1.73				5400	550	1.73							03	- 6100	- 87	B-101	B-117	B-136
			5400	550	2.01				5400	550	2.26							03	- 6105	- 87	B-101	B-117	B-136
13.9	154	15.7	3340	340	1.17	16.8	128	13.0	3340	340	1.42	03	- 6095DA	- 104	B-108	B-124	B-143						
			5400	550	1.62				5400	550	1.72							03	- 6100DA	- 104	B-108	B-124	B-143
			5400	550	1.72				5400	550	1.72							03	- 6105DA	- 104	B-108	B-124	B-143
12.2	186	19.0	5400	550	1.14	14.7	154	15.7	5400	550	1.14	03	- 6105	- 119	B-101	B-117	B-136						
			3340	340	0.89				3340	340	1.08							03	- 6095DA	- 121	B-108	B-124	B-143
			5400	550	1.39				5400	550	1.68							03	- 6100DA	- 121	B-108	B-124	B-143
			5400	550	1.72				5400	550	1.72							03	- 6105DA	- 121	B-108	B-124	B-143
10.1	212	21.6	9810	1000	2.93	14.5	149	15.1	9810	1000	3.53	03	- 6120DB	- 121	B-108	B-124	B-143						
			150	15.3	3340				340	*1	03							- 6090DA	- 143	B-108	B-124	B-143	
			3340	340	0.87				3340	340	1.04							03	- 6095DA	- 143	B-108	B-124	B-143
			5400	550	1.18				5400	550	1.42							03	- 6100DA	- 143	B-108	B-124	B-143
			5400	550	1.42				5400	550	1.71							03	- 6105DA	- 143	B-108	B-124	B-143
			9810	1000	1.72				9810	1000	1.72							03	- 6120DA	- 143	B-108	B-124	B-143
8.79	245	24.9	9810	1000	2.48	12.2	176	17.9	9810	1000	2.99	03	- 6120DB	- 143	B-108	B-124	B-143						
			9810	1000	2.97				9810	1000	3.59							03	- 6125DB	- 143	B-108	B-124	B-143
			200	20.4	3340				340	*1	03							- 6095DA	- 165	B-108	B-124	B-143	
			3340	340	0.82				3340	340	0.98							03	- 6095DA	- 165	B-108	B-124	B-143
			5400	550	1.02				5400	550	1.23							03	- 6100DA	- 165	B-108	B-124	B-143
			5400	550	1.23				5400	550	1.48							03	- 6105DA	- 165	B-108	B-124	B-143
7.44	289	29.5	9810	1000	1.72	10.6	203	20.7	9810	1000	1.72	03	- 6120DA	- 165	B-108	B-124	B-143						
			9810	1000	2.15				9810	1000	2.59							03	- 6120DB	- 165	B-108	B-124	B-143
			9810	1000	2.58				9810	1000	3.11							03	- 6125DB	- 165	B-108	B-124	B-143
			200	20.4	3340				340	*1	03							- 6095DA	- 195	B-108	B-124	B-143	
			5400	550	1.04				5400	550	1.25							03	- 6105DA	- 195	B-108	B-124	B-143
			9810	1000	1.72				9810	1000	1.72							03	- 6120DA	- 195	B-108	B-124	B-143
6.28	342	34.9	9810	1000	1.82	8.97	239	24.4	9810	1000	2.19	03	- 6120DB	- 195	B-108	B-124	B-143						
			9810	1000	2.18				9810	1000	2.63							03	- 6125DB	- 195	B-108	B-124	B-143
			14700	1500	2.70				14700	1500	3.26							03	- 6130DB	- 195	B-109	B-125	B-144
			250	25.5	5400				550	*1	03							- 6100DA	- 231	B-108	B-124	B-143	
			4940	504	0.88				5400	550	1.06							03	- 6105DA	- 231	B-108	B-124	B-143
			9810	1000	1.52				9810	1000	1.72							03	- 6120DA	- 231	B-108	B-124	B-143
5.31	405	41.2	9810	1000	1.52	7.58	284	28.9	9810	1000	1.84	03	- 6120DB	- 231	B-108	B-124	B-143						
			9810	1000	1.56				9810	1000	1.72							03	- 6125DA	- 231	B-108	B-124	B-143
			9810	1000	1.56				9810	1000	1.72							03	- 6125DB	- 231	B-108	B-124	B-143
			14700	1500	1.72				14700	1500	2.22							03	- 6125DA	- 231	B-108	B-124	B-143
			14700	1500	2.28				14700	1500	2.75							03	- 6130DB	- 231	B-109	B-125	B-144
			14700	1500	2.75				14700	1500	3.31							03	- 6135DB	- 231	B-109	B-125	B-144
5.31	405	41.2	14700	1500	1.93	6.41	335	34.2	14700	1500	1.72	03	- 6105DA	- 273	B-108	B-124	B-143						
			14700	1500	2.32				14700	1500	1.56							03	- 6120DA	- 273	B-108	B-124	B-143
			14700	1500	1.93				14700	1500	1.72							03	- 6125DA	- 273	B-108	B-124	B-143
			14700	1500	2.33				14700	1500	1.88							03	- 6125DB	- 273	B-108	B-124	B-143
			14700	1500	2.32				14700	1500	1.72							03	- 6130DA	- 273	B-109	B-125	B-144
			14700	1500	2.80				14700	1500	2.33							03	- 6130DB	- 273	B-109	B-125	B-144
14700	1500	2.80	14700	1500	2.80	03	- 6135DB	- 273	B-109	B-125	B-144												

GEARMOTORS
Selection Tables
0.25 kW

- "*2" indicate models manufactured with reducer and motor separately mounted on a common baseplate (horizontal shaft direction) or on an adaptor (vertical shaft direction). Consult us for details, including dimensions.
- Allowable radial load (Pro) is the value at the midpoint of the slow speed shaft.
- "*3" indicate models with reduction ratios equal to nominal ratio. Refer to Table A-3 "6000SK Series (Actual Reduction Ratio)" on page A-4 for actual reduction ratio. Indicated reduction ratio is the same as actual reduction ratio for other models.
- Maintain torque load during operation within "Output torque" in the table for models with "*" in the SF column. They cannot be operated with 100% motor rating.

Selection Tables Gearmotors

0.25 kW	Hz		50Hz		60Hz	
	P		4	6	4	6
	n ₁	r/min	1450	980	1750	1165

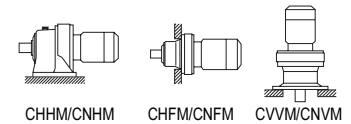

GEARMOTORS
Selection Tables
0.25 kW

50Hz						60Hz						Nomenclature			Page of Dimension Sheet					
Output Speed n ₂ r/min	Output Torque Tout N·m kgf·m		Allowable Radial Load Pro N kgf		SF	Output Speed n ₂ r/min	Output Torque Tout N·m kgf·m		Allowable Radial Load Pro N kgf		SF	Input Capacity - Symbol	Frame - Size	Reduction - Ratio	CNHM	CNFM	CNVM			
4.55	473	48.2	9810	1000	1.10	5.49	392	39.9	9810	1000	1.33	03 - 6120DA	-	319	B-108	B-124	B-143			
			9810	1000	1.33				9810	1000	1.61				03 - 6125DA	-	319	B-108	B-124	B-143
			14700	1500	1.65				14700	1500	1.72				03 - 6130DA	-	319	B-109	B-125	B-144
			14700	1500	1.65				14700	1500	1.99				03 - 6130DB	-	319	B-109	B-125	B-144
			14700	1500	1.72				14700	1500	1.72				03 - 6135DA	-	319	B-109	B-125	B-144
			14700	1500	1.99				14700	1500	2.40				03 - 6135DB	-	319	B-109	B-125	B-144
			16000	1630	2.59				16000	1630	3.13				03 - 6140DB	-	319	B-109	B-125	B-144
3.85	559	56.9	9810	1000	1.13	4.64	463	47.2	9810	1000	1.36	03 - 6125DA	-	377	B-108	B-124	B-143			
			14700	1500	1.40				14700	1500	1.69				03 - 6130DA	-	377	B-109	B-125	B-144
			14700	1500	1.68				14700	1500	1.72				03 - 6135DA	-	377	B-109	B-125	B-144
			14700	1500	1.68				14700	1500	2.03				03 - 6135DB	-	377	B-109	B-125	B-144
			16000	1630	1.72				16000	1630	1.72				03 - 6140DA	-	377	B-109	B-125	B-144
			16000	1630	2.19				16000	1630	2.65				03 - 6140DB	-	377	B-109	B-125	B-144
			16000	1630	2.45				16000	1630	2.96				03 - 6145DB	-	377	B-109	B-125	B-144
3.07	701	71.5	9810	1000	*1	3.70	581	59.2	9810	1000	*1	03 - 6120DA	-	473	B-108	B-124	B-143			
			9810	1000	0.90				9810	1000	1.08				03 - 6125DA	-	473	B-108	B-124	B-143
			14700	1500	1.11				14700	1500	1.34				03 - 6130DA	-	473	B-109	B-125	B-144
			14700	1500	1.34				14700	1500	1.62				03 - 6135DA	-	473	B-109	B-125	B-144
			16000	1630	1.72				16000	1630	1.72				03 - 6140DA	-	473	B-109	B-125	B-144
			16000	1630	1.75				16000	1630	2.11				03 - 6140DB	-	473	B-109	B-125	B-144
			16000	1630	1.95				16000	1630	2.36				03 - 6145DB	-	473	B-109	B-125	B-144
2.59	828	84.4	9810	1000	*1	3.13	686	70.0	9810	1000	*1	03 - 6125DA	-	559	B-108	B-124	B-143			
			14700	1500	1.13				14700	1500	1.37				03 - 6135DA	-	559	B-109	B-125	B-144
			16000	1630	1.48				16000	1630	1.72				03 - 6140DA	-	559	B-109	B-125	B-144
			16000	1630	1.48				16000	1630	1.78				03 - 6140DB	-	559	B-109	B-125	B-144
			16000	1630	1.65				16000	1630	1.72				03 - 6145DA	-	559	B-109	B-125	B-144
			16000	1630	1.65				16000	1630	2.00				03 - 6145DB	-	559	B-109	B-125	B-144
			14700	1500	1.09				14700	1500	1.32				03 - 6135DA	-	649	B-109	B-125	B-144
2.23	962	98.0	16000	1630	1.27	2.70	797	81.2	16000	1630	1.54	03 - 6140DA	-	649	B-109	B-125	B-144			
			16000	1630	1.42				16000	1630	1.72				03 - 6145DA	-	649	B-109	B-125	B-144
			14700	1500	*1				14700	1500	*1				03 - 6130DA	-	731	B-109	B-125	B-144
1.98	1080	110	14700	1500	0.87	2.39	898	91.5	14700	1500	1.05	03 - 6135DA	-	731	B-109	B-125	B-144			
			16000	1630	1.13				16000	1630	1.36				03 - 6140DA	-	731	B-109	B-125	B-144
			16000	1630	1.26				16000	1630	1.53				03 - 6145DA	-	731	B-109	B-125	B-144
1.72	940	95.8	14700	1500	*1	2.08	940	95.8	14700	1500	*1	03 - 6135DA	-	841	B-109	B-125	B-144			
			16000	1630	1.10				16000	1630	1.21				03 - 6145DA	-	841	B-109	B-125	B-144
			16000	1630	1.10				16000	1630	1.33				03 - 6145DB	-	841	B-109	B-125	B-144
1.45	1050	107	14700	1500	*1	1.74	1050	107	14700	1500	*1	03 - 6135DA	-	1003	B-109	B-125	B-144			
			16000	1630	*1				16000	1630	*1				03 - 6140DA	-	1003	B-109	B-125	B-144
			1490	152	16000				1630	0.92	1230				126	16000	1630	1.11	03 - 6145DA	-
1.16	1370	140	15700	1600	*1	1.40	1370	140	15700	1600	*1	03 - 6145DA	-	1247	B-109	B-125	B-144			
0.702	2100	214	22100	2250	*1	0.847	2100	214	22100	2250	*1	03 - 6165DA	-	2065	B-110	B-126	B-145			
0.572	2530	258	29500	3010	*1	0.690	2530	258	29500	3010	*1	03 - 6170DA	-	2537	B-110	B-126	B-145			
0.476	3150	321	29500	3010	*1	0.575	3150	321	29500	3010	*1	03 - 6175DA	-	3045	B-110	B-126	B-145			

1. Combinations in **bold** are the recommended models for operations for 10 hours/day with uniform load (service factor is about 1.0 for motor rating at 50Hz).
2. Motor slippage may affect n₁ and n₂. Refer to technical data for details.
3. CNHM, CHHM, CNFM, CHFM, CNVM, and CVVM indicate types. Refer to page B-10 for details.
4. Lubrication method is different for each model. Refer to "Lubrication" section in page F-4~F-5 for details.
5. "6" at the end of "input capacity symbol" indicates models with 6P motor. Other models come with 4P motor.

Selection Tables Gearmotors

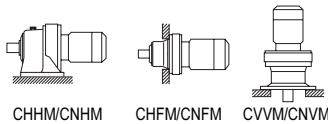

0.4 kW	Hz		50Hz		60Hz	
	P		4	6	4	6
	n ₁	r/min	1450	980	1750	1165

n₁: Motor Speed

50Hz					60Hz					Nomenclature			Page of Dimension Sheet								
Output Speed n ₂ r/min	Output Torque Tout		Allowable Radial Load Pro		SF	Output Speed n ₂ r/min	Output Torque Tout		Allowable Radial Load Pro		SF	Input Capacity Symbol	Frame Size	Reduction Ratio	CNHM	CNFM	CNVM				
	N·m	kgf·m	N	kgf			N·m	kgf·m	N	kgf								CHHM	CHFM	CVVM	
580	6.26	0.638	1180	120	2.78	700	5.18	0.528	1120	114	2.78	05 - 6070SK	- 2.5 *3	B-98	-	B-133					
			1180	120	3.47				1120	114	3.47						05 - 6075SK	- 2.5 *3	B-98	-	B-133
			1310	134	4.12				1250	127	4.12						05 - 6080SK	- 2.5 *3	B-98	-	B-133
483	7.51	0.765	1240	126	2.65	583	6.22	0.634	1180	120	2.65	05 - 6070SK	- 3 *3	B-98	-	B-133					
			1240	126	3.31				1180	120	3.31						05 - 6075SK	- 3 *3	B-98	-	B-133
			1380	141	4.12				1300	133	4.12						05 - 6080SK	- 3 *3	B-98	-	B-133
363	10.0	1.02	1340	137	2.34	438	8.29	0.846	1290	131	2.34	05 - 6070SK	- 4 *3	B-98	-	B-133					
			1340	137	2.92				1290	131	2.92						05 - 6075SK	- 4 *3	B-98	-	B-133
			1500	153	4.12				1420	145	4.12						05 - 6080SK	- 4 *3	B-98	-	B-133
290	12.5	1.28	1370	140	2.22	350	10.4	1.06	1290	132	2.22	05 - 6070SK	- 5 *3	B-98	-	B-133					
			1370	140	2.78				1290	132	2.78						05 - 6075SK	- 5 *3	B-98	-	B-133
			1640	167	3.88				1550	158	3.88						05 - 6080SK	- 5 *3	B-98	-	B-133
242	15.0	1.53	1370	140	1.96	292	12.4	1.27	1290	132	1.96	05 - 6070SK	- 6 *3	B-98	-	B-133					
			1370	140	2.45				1290	132	2.45						05 - 6075SK	- 6 *3	B-98	-	B-133
			1720	175	3.24				1630	166	3.24						05 - 6080SK	- 6 *3	B-98	-	B-133
			1720	175	4.05				1630	166	4.05						05 - 6085SK	- 6 *3	B-98	-	B-133
			1370	140	1.02				1290	132	1.02						05 - 6075	- 6	B-100	B-116	B-135
			1920	196	1.48				1810	184	1.48						05 - 6080	- 6	B-100	B-116	B-135
1920	196	1.95	1810	184	1.95	05 - 6085	- 6	B-100	B-116	B-135											
2860	292	2.88	2690	275	2.88	05 - 6090	- 6	B-100	B-116	B-135											
181	20.0	2.04	1510	154	1.47	219	16.6	1.69	1430	145	1.47	05 - 6070SK	- 8 *3	B-98	-	B-133					
			1510	154	1.84				1430	145	1.84						05 - 6075SK	- 8 *3	B-98	-	B-133
			1820	186	2.74				1730	176	2.74						05 - 6080SK	- 8 *3	B-98	-	B-133
			1820	186	3.43				1730	176	3.43						05 - 6085SK	- 8 *3	B-98	-	B-133
			3280	334	3.76				3110	317	3.76						05 - 6090SK	- 8 *3	B-98	-	B-133
			3280	334	4.43				3110	317	4.43						05 - 6095SK	- 8 *3	B-98	-	B-133
1510	154	1.02	1430	145	1.02	05 - 6075	- 8	B-100	B-116	B-135											
2080	212	1.48	1960	200	1.48	05 - 6080	- 8	B-100	B-116	B-135											
2080	212	1.95	1960	200	1.95	05 - 6085	- 8	B-100	B-116	B-135											
3190	326	2.88	3000	306	2.88	05 - 6090	- 8	B-100	B-116	B-135											
145	25.0	2.55	1680	171	1.13	175	20.7	2.11	1590	162	1.13	05 - 6070SK	- 10 *3	B-98	-	B-133					
			1680	171	1.42				1590	162	1.42						05 - 6075SK	- 10 *3	B-98	-	B-133
			1930	197	2.20				1840	188	2.20						05 - 6080SK	- 10 *3	B-98	-	B-133
			1930	197	2.75				1840	188	2.75						05 - 6085SK	- 10 *3	B-98	-	B-133
			3590	366	3.50				3390	346	3.50						05 - 6090SK	- 10 *3	B-98	-	B-133
			3590	366	4.43				3390	346	4.43						05 - 6095SK	- 10 *3	B-98	-	B-133
132	27.5	2.81	1680	171	1.02	159	22.8	2.33	1590	162	1.02	05 - 6075	- 11	B-100	B-116	B-135					
			2300	234	1.48				2160	220	1.48						05 - 6080	- 11	B-100	B-116	B-135
			2300	234	1.95				2160	220	1.95						05 - 6085	- 11	B-100	B-116	B-135
			3340	340	2.88				3340	340	2.88						05 - 6090	- 11	B-100	B-116	B-135
112	32.5	3.32	1770	180	1.02	135	27.0	2.75	1680	171	1.02	05 - 6075	- 13	B-100	B-116	B-135					
			2470	251	1.48				2320	237	1.48						05 - 6080	- 13	B-100	B-116	B-135
			2470	251	1.95				2320	237	1.95						05 - 6085	- 13	B-100	B-116	B-135
			3340	340	2.88				3340	340	2.88						05 - 6090	- 13	B-100	B-116	B-135
96.7	37.5	3.83	1770	180	1.02	117	31.1	3.17	1680	171	1.02	05 - 6075	- 15	B-100	B-116	B-135					
			2550	260	1.48				2400	245	1.48						05 - 6080	- 15	B-100	B-116	B-135
			2550	260	1.95				2400	245	1.95						05 - 6085	- 15	B-100	B-116	B-135
			3340	340	2.88				3340	340	2.88						05 - 6090	- 15	B-100	B-116	B-135
85.3	42.5	4.34	1770	180	1.02	103	35.3	3.59	1770	180	1.02	05 - 6075	- 17	B-100	B-116	B-135					
			2560	261	1.48				2510	256	1.48						05 - 6080	- 17	B-100	B-116	B-135
			2560	261	1.95				2510	256	1.95						05 - 6085	- 17	B-100	B-116	B-135
			3340	340	2.88				3340	340	2.88						05 - 6090	- 17	B-100	B-116	B-135
69.0	52.6	5.36	1770	180	1.02	83.3	43.5	4.44	1770	180	1.02	05 - 6075	- 21	B-100	B-116	B-135					
			2560	261	1.20				2450	250	1.20						05 - 6080	- 21	B-100	B-116	B-135
			2560	261	1.38				2450	250	1.38						05 - 6085	- 21	B-100	B-116	B-135
			3340	340	1.90				3340	340	1.90						05 - 6090	- 21	B-100	B-116	B-135

GEARMOTORS
Selection Tables
0.4 kW

- "*2" indicate models manufactured with reducer and motor separately mounted on a common baseplate (horizontal shaft direction) or on an adaptor (vertical shaft direction). Consult us for details, including dimensions.
- Allowable radial load (Pro) is the value at the midpoint of the slow speed shaft.
- "*3" indicate models with reduction ratios equal to nominal ratio. Refer to Table A-3 "6000SK Series (Actual Reduction Ratio)" on page A-4 for actual reduction ratio. Indicated reduction ratio is the same as actual reduction ratio for other models.
- Maintain torque load during operation within "Output torque" in the table for models with "*" in the SF column. They cannot be operated with 100% motor rating.

Selection Tables Gearmotors

0.4 kW		n ₁ : Motor Speed							
		Hz		50Hz		60Hz			
		P		4	6	4	6		
n ₁ r/min		1450		980		1750		1165	

50Hz						60Hz						Nomenclature			Page of Dimension Sheet								
Output Speed n ₂ r/min	Output Torque Tout		Allowable Radial Load Pro		SF	Output Speed n ₂ r/min	Output Torque Tout		Allowable Radial Load Pro		SF	Input Capacity Symbol	Frame Size	Reduction Ratio	CNHM	CNFM	CNVM	CHHM	CHFM	CVVM			
	N·m	kgf·m	N	kgf			N·m	kgf·m	N	kgf													
58.0	62.6	6.38	2560	261	1.19	70.0	51.8	5.28	2520	256	1.19	05 -	6085	- 25	B-100	B-116	B-135	B-100	B-116	B-135			
			3340	340	1.68				3340	340	1.68										05 -	6090	- 25
			3340	340	2.17				3340	340	2.17										05 -	6095	- 25
50.0	72.6	7.40	2560	261	1.17	60.3	60.1	6.13	2560	261	1.17	05 -	6085	- 29	B-100	B-116	B-135	B-100	B-116	B-135			
			3340	340	1.56				3340	340	1.56										05 -	6090	- 29
			3340	340	1.96				3340	340	1.96										05 -	6095	- 29
41.4	87.6	8.93	2560	261	0.82	50.0	72.6	7.40	2560	261	0.93	05 -	6085	- 35	B-100	B-116	B-135	B-100	B-116	B-135			
			3340	340	1.53				3340	340	1.53										05 -	6090	- 35
			3340	340	1.90				3340	340	1.90										05 -	6095	- 35
			5400	550	2.44				5400	550	2.44										05 -	6100	- 35
33.7	108	11.0	3340	340	1.09	40.7	89.2	9.09	3340	340	1.09	05 -	6090	- 43	B-100	B-116	B-135	B-100	B-116	B-135			
			3340	340	1.51				3340	340	1.51										05 -	6095	- 43
			5400	550	1.95				5400	550	1.95										05 -	6100	- 43
			5400	550	2.70				5400	550	2.70										05 -	6105	- 43
28.4	128	13.0	3320	339	1.02	34.3	106	10.8	3340	340	1.06	05 -	6095	- 51	B-100	B-116	B-135	B-101	B-117	B-136			
			5400	550	1.40				5400	550	1.40										05 -	6100	- 51
			5400	550	1.94				5400	550	1.94										05 -	6105	- 51
			7610	776	2.36				7610	776	2.36										05 -	6110	- 51
24.6	148	15.1	3300	336	0.84	29.7	122	12.5	3340	340	0.93	05 -	6095	- 59	B-100	B-116	B-135	B-101	B-117	B-136			
			5400	550	1.29				5400	550	1.29										05 -	6100	- 59
			5400	550	1.70				5400	550	1.77										05 -	6105	- 59
			7610	776	2.15				7610	776	2.15										05 -	6110	- 59
20.4	178	18.1	5400	550	1.09	24.6	147	15.0	5400	550	1.09	05 -	6100	- 71	B-101	B-117	B-136	B-101	B-117	B-136			
			5400	550	1.27				5400	550	1.40										05 -	6105	- 71
			7610	776	1.67				7610	776	1.67										05 -	6110	- 71
			7610	776	1.90				7610	776	1.90										05 -	6115	- 71
16.7	218	22.2	9810	1000	2.39	20.1	180	18.4	9810	1000	2.39	05 -	6120	- 71	B-101	B-117	B-136	B-101	B-117	B-136			
			9810	1000	2.85				9810	1000	3.00										05 -	6125	- 71
			5400	550	1.08				5400	550	1.08										05 -	6100	- 87
			5400	550	1.26				5400	550	1.41										05 -	6105	- 87
13.9	150	15.3	3340	340	*1	16.8	150	15.3	3340	340	*1	05 -	6090DA	- 104	B-108	B-124	B-143	B-108	B-124	B-143			
			3340	340	*1				3340	340	*1										05 -	6095DA	- 104
			5400	550	1.01				5400	550	1.07										05 -	6100DA	- 104
			5400	550	1.07				5400	550	1.07										05 -	6105DA	- 104
12.0	150	15.3	3340	340	*1	14.5	150	15.3	3340	340	*1	05 -	6090DA	- 121	B-108	B-124	B-143	B-108	B-124	B-143			
			3340	340	*1				3340	340	*1										05 -	6095DA	- 121
			5400	550	1.07				5400	550	1.07										05 -	6105DA	- 121
			9810	1000	1.83				9810	1000	2.21										05 -	6120DB	- 121
12.0	160	16.4	3340	340	*1	14.5	160	16.4	3340	340	*1	05 -	6095DA	- 121	B-108	B-124	B-143	B-108	B-124	B-143			
			9810	1000	2.17				9810	1000	2.62										05 -	6125DB	- 121
			9810	1000	2.17				9810	1000	2.62										05 -	6125DB	- 121
			14700	1500	2.72				14700	1500	3.28										05 -	6130DB	- 121

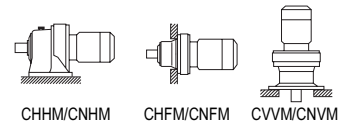

GEARMOTORS

Selection Tables
0.4 kW

1. Combinations in **bold** are the recommended models for operations for 10 hours/day with uniform load (service factor is about 1.0 for motor rating at 50Hz).
2. Motor slippage may affect n₁ and n₂. Refer to technical data for details.
3. CNHM, CHHM, CNFM, CHFM, CNVM, and CVVM indicate types. Refer to page B-10 for details.
4. Lubrication method is different for each model. Refer to "Lubrication" section in page F-4~F-5 for details.
5. "6" at the end of "input capacity symbol" indicates models with 6P motor. Other models come with 4P motor.

Selection Tables Gearmotors

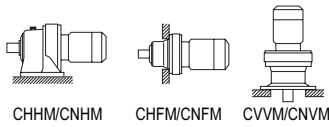

0.4 kW	Hz		50Hz		60Hz	
	P		4	6	4	6
	n ₁	r/min	1450	980	1750	1165

n₁: Motor Speed

50Hz					60Hz					Nomenclature			Page of Dimension Sheet			
Output Speed n ₂ r/min	Output Torque Tout		Allowable Radial Load Pro		SF	Output Speed n ₂ r/min	Output Torque Tout		Allowable Radial Load Pro		Input Capacity - Symbol	Frame Size - Ratio	Reduction Ratio	CNHM	CNFM	CNVM
	N·m	kgf·m	N	kgf			N·m	kgf·m	N	kgf						
10.1	183	18.7	3340	340	*1	12.2	183	18.7	3340	340	*1	05 - 6095DA	- 143	B-108	B-124	B-143
	250	25.5	5400	550	*1		250	25.5	5400	550	*1	05 - 6100DA	- 143	B-108	B-124	B-143
			5400	550	0.88				5400	550	1.07	05 - 6105DA	- 143	B-108	B-124	B-143
			9810	1000	1.07				9810	1000	1.07	05 - 6120DA	- 143	B-108	B-124	B-143
			9810	1000	1.55				9810	1000	1.87	05 - 6120DB	- 143	B-108	B-124	B-143
	339	34.6	9810	1000	1.86		281	28.6	9810	1000	2.24	05 - 6125DB	- 143	B-108	B-124	B-143
		14700	1500	2.30			14700	1500	2.78	05 - 6130DB	- 143	B-109	B-125	B-144		
		14700	1500	2.77			14700	1500	3.35	05 - 6135DB	- 143	B-109	B-125	B-144		
8.79	250	25.5	5400	550	*1	10.6	250	25.5	5400	550	*1	05 - 6100DA	- 165	B-108	B-124	B-143
	300	30.6	5400	550	*1		300	30.6	5400	550	*1	05 - 6105DA	- 165	B-108	B-124	B-143
			9810	1000	1.07				9810	1000	1.07	05 - 6120DA	- 165	B-108	B-124	B-143
			9810	1000	1.34				9810	1000	1.62	05 - 6120DB	- 165	B-108	B-124	B-143
	391	39.9	9810	1000	1.61		324	33.0	9810	1000	1.94	05 - 6125DB	- 165	B-108	B-124	B-143
			14700	1500	1.99				14700	1500	2.41	05 - 6130DB	- 165	B-109	B-125	B-144
		14700	1500	2.40			14700	1500	2.90	05 - 6135DB	- 165	B-109	B-125	B-144		
7.44	250	25.5	5400	550	*1	8.97	250	25.5	5400	550	*1	05 - 6100DA	- 195	B-108	B-124	B-143
	300	30.6	5400	550	*1		300	30.6	5400	550	*1	05 - 6105DA	- 195	B-108	B-124	B-143
			9810	1000	1.07				9810	1000	1.07	05 - 6120DA	- 195	B-108	B-124	B-143
			9810	1000	1.14				9810	1000	1.37	05 - 6120DB	- 195	B-108	B-124	B-143
			9810	1000	1.36				9810	1000	1.64	05 - 6125DB	- 195	B-108	B-124	B-143
	462	47.1	14700	1500	1.69		383	39.1	14700	1500	2.04	05 - 6130DB	- 195	B-109	B-125	B-144
		14700	1500	2.03			14700	1500	2.45	05 - 6135DB	- 195	B-109	B-125	B-144		
		16000	1630	2.65			16000	1630	3.20	05 - 6140DB	- 195	B-109	B-125	B-144		
		16000	1630	2.94			16000	1630	3.54	05 - 6145DB	- 195	B-109	B-125	B-144		
6.28	300	30.6	5400	550	*1	7.58	300	30.6	5400	550	*1	05 - 6105DA	- 231	B-108	B-124	B-143
			9810	1000	1.07				9810	1000	1.07	05 - 6125DA	- 231	B-108	B-124	B-143
			9810	1000	1.15				9810	1000	1.39	05 - 6125DB	- 231	B-108	B-124	B-143
			14700	1500	1.42				14700	1500	1.72	05 - 6130DB	- 231	B-109	B-125	B-144
	548	55.8	14700	1500	1.72		454	46.3	14700	1500	2.07	05 - 6135DB	- 231	B-109	B-125	B-144
			16000	1630	2.24				16000	1630	2.70	05 - 6140DB	- 231	B-109	B-125	B-144
		16000	1630	2.44			16000	1630	2.95	05 - 6145DB	- 231	B-109	B-125	B-144		
5.31	522	53.2	9810	1000	*1	6.41	522	53.2	9810	1000	*1	05 - 6120DA	- 273	B-108	B-124	B-143
			9810	1000	0.97				9810	1000	1.07	05 - 6125DA	- 273	B-108	B-124	B-143
			9810	1000	0.97				9810	1000	1.17	05 - 6125DB	- 273	B-108	B-124	B-143
			14700	1500	1.07				14700	1500	1.07	05 - 6130DA	- 273	B-109	B-125	B-144
			14700	1500	1.21				14700	1500	1.45	05 - 6130DB	- 273	B-109	B-125	B-144
	647	66.0	14700	1500	1.45		536	54.7	14700	1500	1.75	05 - 6135DB	- 273	B-109	B-125	B-144
		16000	1630	1.89			16000	1630	2.28	05 - 6140DB	- 273	B-109	B-125	B-144		
		16000	1630	2.07			16000	1630	2.49	05 - 6145DB	- 273	B-109	B-125	B-144		
		22100	2250	2.71			22100	2250	3.27	05 - 6160DA	- 273	B-110	B-126	B-145		
4.55	520	53.0	9810	1000	*1	5.49	520	53.0	9810	1000	*1	05 - 6120DA	- 319	B-108	B-124	B-143
			9810	1000	0.83				9810	1000	1.01	05 - 6125DA	- 319	B-108	B-124	B-143
			14700	1500	1.03				14700	1500	1.07	05 - 6130DA	- 319	B-109	B-125	B-144
			14700	1500	1.03				14700	1500	1.24	05 - 6130DB	- 319	B-109	B-125	B-144
			14700	1500	1.07				14700	1500	1.07	05 - 6135DA	- 319	B-109	B-125	B-144
	756	77.1	14700	1500	1.24		627	63.9	14700	1500	1.50	05 - 6135DB	- 319	B-109	B-125	B-144
		16000	1630	1.62			16000	1630	1.95	05 - 6140DB	- 319	B-109	B-125	B-144		
		16000	1630	1.81			16000	1630	2.19	05 - 6145DB	- 319	B-109	B-125	B-144		
		22100	2250	2.32			22100	2250	2.80	05 - 6160DA	- 319	B-110	B-126	B-145		
		22100	2250	2.78			22100	2250	3.35	05 - 6165DA	- 319	B-110	B-126	B-145		

GEARMOTORS
Selection Tables
0.4 kW

- "*2" indicate models manufactured with reducer and motor separately mounted on a common baseplate (horizontal shaft direction) or on an adaptor (vertical shaft direction). Consult us for details, including dimensions.
- Allowable radial load (Pro) is the value at the midpoint of the slow speed shaft.
- "*3" indicate models with reduction ratios equal to nominal ratio. Refer to Table A-3 "6000SK Series (Actual Reduction Ratio)" on page A-4 for actual reduction ratio. Indicated reduction ratio is the same as actual reduction ratio for other models.
- Maintain torque load during operation within "Output torque" in the table for models with "*" in the SF column. They cannot be operated with 100% motor rating.

Selection Tables Gearmotors

0.4 kW	Hz		50Hz		60Hz	
	P		4	6	4	6
	n ₁	r/min	1450	980	1750	1165

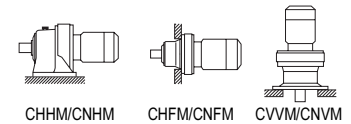

50Hz						60Hz						Nomenclature			Page of Dimension Sheet			
Output Speed n ₂ r/min	Output Torque Tout		Allowable Radial Load Pro		SF	Output Speed n ₂ r/min	Output Torque Tout		Allowable Radial Load Pro		SF	Input Capacity Symbol	Frame Size	Reduction Ratio	CNHM	CNFM	CNVM	
	N·m	kgf·m	N	kgf			N·m	kgf·m	N	kgf								
3.85	520	53.0	9810	1000	*1	4.64	520	53.0	9810	1000	*1	05 - 6120DA	- 377	B-108	B-124	B-143		
	630	64.2	9810	1000	*1		630	64.2	9810	1000	*1	05 - 6125DA	- 377	B-108	B-124	B-143		
			14700	1500	1.05					14700	1500	1.07	05 - 6135DA	- 377	B-109	B-125	B-144	
			14700	1500	1.05					14700	1500	1.27	05 - 6135DB	- 377	B-109	B-125	B-144	
			16000	1630	1.07					16000	1630	1.07	05 - 6140DA	- 377	B-109	B-125	B-144	
	894	91.1	16000	1630	1.37		741	75.5	16000	1630	1.65	05 - 6140DB	- 377	B-109	B-125	B-144		
			16000	1630	1.53				16000	1630	1.85	05 - 6145DB	- 377	B-109	B-125	B-144		
			22100	2250	1.96				22100	2250	2.37	05 - 6160DA	- 377	B-110	B-126	B-145		
			22100	2250	2.35				22100	2250	2.84	05 - 6165DA	- 377	B-110	B-126	B-145		
			29500	3010	2.83				29500	3010	3.42	05 - 6170DA	- 377	B-110	B-126	B-145		
3.07	630	64.2	9810	1000	*1	3.70	630	64.2	9810	1000	*1	05 - 6125DA	- 473	B-108	B-124	B-143		
	780	79.5	14700	1500	*1		780	79.5	14700	1500	*1	05 - 6130DA	- 473	B-109	B-125	B-144		
			14700	1500	0.84					14700	1500	1.01	05 - 6135DA	- 473	B-109	B-125	B-144	
			16000	1630	1.07					16000	1630	1.07	05 - 6140DA	- 473	B-109	B-125	B-144	
			16000	1630	1.09					16000	1630	1.32	05 - 6140DB	- 473	B-109	B-125	B-144	
	1120	114	16000	1630	1.22		929	94.7	16000	1630	1.47	05 - 6145DB	- 473	B-109	B-125	B-144		
			22100	2250	1.55				22100	2250	1.87	05 - 6160DA	- 473	B-110	B-126	B-145		
			22100	2250	1.87				22100	2250	2.26	05 - 6165DA	- 473	B-110	B-126	B-145		
			29500	3010	2.26				29500	3010	2.72	05 - 6170DA	- 473	B-110	B-126	B-145		
			29500	3010	2.81				29500	3010	3.39	05 - 6175DA	- 473	B-110	B-126	B-145		
2.59	780	79.5	14700	1500	*1	3.13	780	79.5	14700	1500	*1	05 - 6130DA	- 559	B-109	B-125	B-144		
	940	95.8	14700	1500	*1		940	95.8	14700	1500	*1	05 - 6135DA	- 559	B-109	B-125	B-144		
			15900	1620	1.03					16000	1630	1.07	05 - 6145DA	- 559	B-109	B-125	B-144	
			15900	1620	1.03					16000	1630	1.25	05 - 6145DB	- 559	B-109	B-125	B-144	
			22100	2250	1.31					22100	2250	1.58	05 - 6160DA	- 559	B-110	B-126	B-145	
	1330	135	22100	2250	1.58		1100	112	22100	2250	1.91	05 - 6165DA	- 559	B-110	B-126	B-145		
			29500	3010	1.91				29500	3010	2.30	05 - 6170DA	- 559	B-110	B-126	B-145		
			29500	3010	2.38				29500	3010	2.87	05 - 6175DA	- 559	B-110	B-126	B-145		
2.23	912	93.0	14700	1500	*1	2.70	912	93.0	14700	1500	*1	05 - 6130DA	- 649	B-109	B-125	B-144		
	1050	107	14700	1500	*1		1050	107	14700	1500	*1	05 - 6135DA	- 649	B-109	B-125	B-144		
	1230	125	16000	1630	*1		1230	125	16000	1630	*1	05 - 6140DA	- 649	B-109	B-125	B-144		
			16000	1630	0.89					16000	1630	1.07	05 - 6145DA	- 649	B-109	B-125	B-144	
			22100	2250	1.14					22100	2250	1.38	05 - 6160DA	- 649	B-110	B-126	B-145	
	1540	157	22100	2250	1.36		1280	130	22100	2250	1.65	05 - 6165DA	- 649	B-110	B-126	B-145		
			29500	3010	1.64				29500	3010	1.98	05 - 6170DA	- 649	B-110	B-126	B-145		
			29500	3010	2.05				29500	3010	2.47	05 - 6175DA	- 649	B-110	B-126	B-145		
1.98	940	95.8	14700	1500	*1	2.39	940	95.8	14700	1500	*1	05 - 6135DA	- 731	B-109	B-125	B-144		
	1230	125	16000	1630	*1		1230	125	16000	1630	*1	05 - 6140DA	- 731	B-109	B-125	B-144		
	1370	140	15700	1600	*1		1370	140	15700	1600	*1	05 - 6145DA	- 731	B-109	B-125	B-144		
			22100	2250	1.00					22100	2250	1.21	05 - 6160DA	- 731	B-110	B-126	B-145	
			22100	2250	1.21					22100	2250	1.46	05 - 6165DA	- 731	B-110	B-126	B-145	
	1730	177	29500	3010	1.46		1440	146	29500	3010	1.76	05 - 6170DA	- 731	B-110	B-126	B-145		
			29500	3010	1.82				29500	3010	2.19	05 - 6175DA	- 731	B-110	B-126	B-145		
1.72	1230	125	16000	1630	*1	2.08	1230	125	16000	1630	*1	05 - 6140DA	- 841	B-109	B-125	B-144		
	1370	140	15800	1610	*1		1250	127	16000	1630	*1	05 - 6145DA	- 841	B-109	B-125	B-144		
			22100	2250	1.05					22100	2250	1.27	05 - 6165DA	- 841	B-110	B-126	B-145	
	1990	203	29500	3010	1.27		1650	168	29500	3010	1.53	05 - 6170DA	- 841	B-110	B-126	B-145		
			29500	3010	1.58				29500	3010	1.91	05 - 6175DA	- 841	B-110	B-126	B-145		
1.45	1370	140	16000	1630	*1	1.74	1370	140	16000	1630	*1	05 - 6145DA	- 1003	B-109	B-125	B-144		
	1760	179	22100	2250	*1		1760	179	22100	2250	*1	05 - 6160DA	- 1003	B-110	B-126	B-145		
			22100	2250	0.88					22100	2250	1.07	05 - 6165DA	- 1003	B-110	B-126	B-145	
	2380	242	29500	3010	1.06		1970	201	29500	3010	1.28	05 - 6170DA	- 1003	B-110	B-126	B-145		
			29500	3010	1.32				29500	3010	1.60	05 - 6175DA	- 1003	B-110	B-126	B-145		
1.16	1740	177	22100	2250	*1	1.40	1740	177	22100	2250	*1	05 - 6160DA	- 1247	B-110	B-126	B-145		
	2100	214	22100	2250	*1		2100	214	22100	2250	*1	05 - 6165DA	- 1247	B-110	B-126	B-145		
	2960	301	29500	3010	1.07		2450	250	29500	3010	1.29	05 - 6175DA	- 1247	B-110	B-126	B-145		

1. Combinations in **bold** are the recommended models for operations for 10 hours/day with uniform load (service factor is about 1.0 for motor rating at 50Hz).
2. Motor slippage may affect n₁ and n₂. Refer to technical data for details.
3. CNHM, CHHM, CNFM, CHFM, CNVM, and CVVM indicate types. Refer to page B-10 for details.
4. Lubrication method is different for each model. Refer to "Lubrication" section in page F-4~F-5 for details.
5. "6" at the end of "input capacity symbol" indicates models with 6P motor. Other models come with 4P motor.

Selection Tables Gearmotors

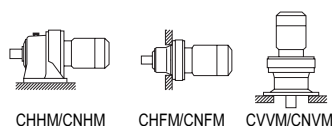

0.4 kW	Hz		50Hz		60Hz	
	P		4	6	4	6
	n ₁	r/min	1450	980	1750	1165

50Hz						60Hz					Nomenclature			Page of Dimension Sheet			
Output Speed n ₂ r/min	Output Torque Tout		Allowable Radial Load Pro		SF	Output Speed n ₂ r/min	Output Torque Tout		Allowable Radial Load Pro		SF	Input Capacity Symbol	Frame Size	Reduction Ratio	CNHM	CNFM	CNVM
	N·m	kgf·m	N	kgf			N·m	kgf·m	N	kgf							
0.980	1760	179	22100	2250	*1	1.18	1760	179	22100	2250	*1	05 - 6160DA	-1479	B-110	B-126	B-145	
	2050	209	21800	2220	*1		2050	209	21800	2220	*1	05 - 6165DA	-1479	B-110	B-126	B-145	
	2530	258	29500	3010	*1		2530	258	29500	3010	*1	05 - 6170DA	-1479	B-110	B-126	B-145	
	3510	357	29500	3010	0.90		2910	296	29500	3010	1.08	05 - 6175DA	-1479	B-110	B-126	B-145	
0.784	2100	214	22100	2250	*1	0.946	2100	214	22100	2250	*1	05 - 6165DA	-1849	B-110	B-126	B-145	
	2530	258	29500	3010	*1		2530	258	29500	3010	*1	05 - 6170DA	-1849	B-110	B-126	B-145	
	3150	321	29500	3010	*1		3150	321	29500	3010	*1	05 - 6175DA	-1849	B-110	B-126	B-145	
	4380	447	41700	4250	0.93		3630	370	41700	4250	1.12	05 - 6180DA	-1849	B-110	B-126	B-145	
0.702	2530	258	29500	3010	*1	0.847	2530	258	29500	3010	*1	05 - 6170DA	-2065	B-110	B-126	B-145	
	3150	321	29500	3010	*1		3150	321	29500	3010	*1	05 - 6175DA	-2065	B-110	B-126	B-145	
	4050	413	41700	4250	*1		4050	413	41700	4250	*1	05 - 6180DA	-2065	B-110	B-126	B-145	
0.572	3150	321	29500	3010	*1	0.690	3150	321	29500	3010	*1	05 - 6175DA	-2537	B-110	B-126	B-145	
	4050	413	41700	4250	*1		4050	413	41700	4250	*1	05 - 6180DA	-2537	B-110	B-126	B-145	
	5000	510	41600	4240	*1		5000	510	41600	4240	*1	05 - 6185DA	-2537	B-110	B-126	B-145	
	6020	613	41200	4200	0.83		4980	508	41600	4240	1.00	05 - 6185DA	-2537	B-110	B-126	B-145	
0.476	4060	414	41700	4250	*1	0.575	4060	414	41700	4250	*1	05 - 6180DA	-3045	B-110	B-126	B-145	
	5000	510	41700	4250	*1		5000	510	41700	4250	*1	05 - 6185DA	-3045	B-110	B-126	B-145	
0.417	4050	413	41700	4250	*1	0.503	4050	413	41700	4250	*1	05 - 6180DA	-3481	B-110	B-126	B-145	
	5000	510	41600	4240	*1		5000	510	41600	4240	*1	05 - 6185DA	-3481	B-110	B-126	B-145	
0.327	4060	414	41700	4250	*1	0.394	4060	414	41700	4250	*1	05 - 6180DA	-4437	B-110	B-126	B-145	
	5000	510	41700	4250	*1		5000	510	41700	4250	*1	05 - 6185DA	-4437	B-110	B-126	B-145	
0.282	4060	414	41700	4250	*1	0.341	4060	414	41700	4250	*1	05 - 6180DA	-5133	B-110	B-126	B-145	
	5000	510	41700	4250	*1		5000	510	41700	4250	*1	05 - 6185DA	-5133	B-110	B-126	B-145	
0.235	4060	414	41700	4250	*1	0.283	4060	414	41700	4250	*1	05 - 6180DA	-6177	B-110	B-126	B-145	
	5000	510	41700	4250	*1		5000	510	41700	4250	*1	05 - 6185DA	-6177	B-110	B-126	B-145	
0.192	4060	414	41700	4250	*1	0.231	4060	414	41700	4250	*1	05 - 6180DA	-7569	B-110	B-126	B-145	
	5000	510	41700	4250	*1		5000	510	41700	4250	*1	05 - 6185DA	-7569	B-110	B-126	B-145	

GEARMOTORS

Selection Tables
0.4 kW

- "*2" indicate models manufactured with reducer and motor separately mounted on a common baseplate (horizontal shaft direction) or on an adaptor (vertical shaft direction). Consult us for details, including dimensions.
- Allowable radial load (Pro) is the value at the midpoint of the slow speed shaft.
- "*3" indicate models with reduction ratios equal to nominal ratio. Refer to Table A-3 "6000SK Series (Actual Reduction Ratio)" on page A-4 for actual reduction ratio. Indicated reduction ratio is the same as actual reduction ratio for other models.
- Maintain torque load during operation within "Output torque" in the table for models with "*" in the SF column. They cannot be operated with 100% motor rating.

Selection Tables Gearmotors

0.55 kW	Hz		50Hz		60Hz	
	P		4	6	4	6
	n ₁	r/min	1450	980	1750	1165
	n ₁ : Motor Speed					

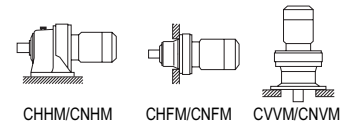

50Hz					60Hz					Nomenclature			Page of Dimension Sheet						
Output Speed n ₂ r/min	Output Torque T _{out} N·m kgf·m		Allowable Radial Load Pro N kgf		SF	Output Speed n ₂ r/min	Output Torque T _{out} N·m kgf·m		Allowable Radial Load Pro N kgf		SF	Input Capacity Symbol	Frame Size	Reduction Ratio	CNHM	CNFM	CNVM		
															CHHM	CHFM	CVVM		
580	8.60	0.877	1170	119	2.02	700	7.13	0.727	1100	112	2.02	08 -	6070SK	- 2.5 *3	B-98	-	B-133		
			1170	119	2.53				1100	112	2.53				08 - 6075SK	- 2.5 *3	B-98	-	B-133
			1290	131	3.00				1220	124	3.00				08 - 6080SK	- 2.5 *3	B-98	-	B-133
			1290	131	3.75				1220	124	3.75				08 - 6085SK	- 2.5 *3	B-98	-	B-133
			2280	232	4.36				2150	219	4.36				08 - 6090SK	- 2.5 *3	B-98	-	B-133
483	10.3	1.05	1220	124	1.93	583	8.55	0.872	1150	117	1.93	08 -	6070SK	- 3 *3	B-98	-	B-133		
			1220	124	2.41				1150	117	2.41				08 - 6075SK	- 3 *3	B-98	-	B-133
			1350	138	3.00				1290	131	3.00				08 - 6080SK	- 3 *3	B-98	-	B-133
			1350	138	3.75				1290	131	3.75				08 - 6085SK	- 3 *3	B-98	-	B-133
			2380	243	4.25				2250	229	4.25				08 - 6090SK	- 3 *3	B-98	-	B-133
363	13.8	1.40	1320	135	1.70	438	11.4	1.16	1260	128	1.70	08 -	6070SK	- 4 *3	B-98	-	B-133		
			1320	135	2.12				1260	128	2.12				08 - 6075SK	- 4 *3	B-98	-	B-133
			1470	150	3.00				1390	142	3.00				08 - 6080SK	- 4 *3	B-98	-	B-133
			1470	150	3.75				1390	142	3.75				08 - 6085SK	- 4 *3	B-98	-	B-133
			2670	272	4.25				2560	261	4.25				08 - 6090SK	- 4 *3	B-98	-	B-133
290	17.2	1.75	1370	140	1.61	350	14.3	1.45	1290	132	1.61	08 -	6070SK	- 5 *3	B-98	-	B-133		
			1370	140	2.02				1290	132	2.02				08 - 6075SK	- 5 *3	B-98	-	B-133
			1590	162	2.82				1510	154	2.82				08 - 6080SK	- 5 *3	B-98	-	B-133
			1590	162	3.31				1510	154	3.31				08 - 6085SK	- 5 *3	B-98	-	B-133
			2880	294	4.06				2730	278	4.06				08 - 6090SK	- 5 *3	B-98	-	B-133
242	20.6	2.10	1370	140	1.42	292	17.1	1.74	1290	132	1.42	08 -	6070SK	- 6 *3	B-98	-	B-133		
			1370	140	1.78				1290	132	1.78				08 - 6075SK	- 6 *3	B-98	-	B-133
			1660	169	2.36				1580	161	2.36				08 - 6080SK	- 6 *3	B-98	-	B-133
			1660	169	2.95				1580	161	2.95				08 - 6085SK	- 6 *3	B-98	-	B-133
			2950	301	3.47				2810	286	3.47				08 - 6090SK	- 6 *3	B-98	-	B-133
			2950	301	4.13				2810	286	4.13				08 - 6095SK	- 6 *3	B-98	-	B-133
			1910	195	1.08				1800	183	1.08				08 - 6080	- 6	B-100	B-116	B-135
			1910	195	1.41				1800	183	1.41				08 - 6085	- 6	B-100	B-116	B-135
			2850	291	2.09				2690	274	2.09				08 - 6090	- 6	B-100	B-116	B-135
			2850	291	2.76				2690	274	2.76				08 - 6095	- 6	B-100	B-116	B-135
181	27.5	2.81	1510	154	1.07	219	22.8	2.33	1420	145	1.07	08 -	6070SK	- 8 *3	B-98	-	B-133		
			1510	154	1.34				1420	145	1.34				08 - 6075SK	- 8 *3	B-98	-	B-133
			1750	178	1.99				1670	170	1.99				08 - 6080SK	- 8 *3	B-98	-	B-133
			1750	178	2.49				1670	170	2.49				08 - 6085SK	- 8 *3	B-98	-	B-133
			3300	336	2.74				3140	320	2.74				08 - 6090SK	- 8 *3	B-98	-	B-133
			3300	336	3.22				3140	320	3.22				08 - 6095SK	- 8 *3	B-98	-	B-133
			3300	336	3.85				3140	320	3.85				08 - 6100SK	- 8 *3	B-99	-	B-134
			2070	211	1.08				1950	198	1.08				08 - 6080	- 8	B-100	B-116	B-135
			2070	211	1.41				1950	198	1.41				08 - 6085	- 8	B-100	B-116	B-135
			3180	324	2.09				2990	305	2.09				08 - 6090	- 8	B-100	B-116	B-135
3180	324	2.76	2990	305	2.76	08 - 6095	- 8	B-100	B-116	B-135									
145	34.4	3.51	1680	171	1.03	175	28.5	2.91	1590	162	1.03	08 -	6075SK	- 10 *3	B-98	-	B-133		
			1840	188	1.60				1770	180	1.60				08 - 6080SK	- 10 *3	B-98	-	B-133
			1840	188	2.00				1770	180	2.00				08 - 6085SK	- 10 *3	B-98	-	B-133
			3490	356	2.55				3330	339	2.55				08 - 6090SK	- 10 *3	B-98	-	B-133
			3490	356	3.22				3330	339	3.22				08 - 6095SK	- 10 *3	B-98	-	B-133
			3490	356	3.60				3330	339	3.60				08 - 6100SK	- 10 *3	B-99	-	B-134
			3490	356	4.00				3330	339	4.00				08 - 6105SK	- 10 *3	B-99	-	B-134
132	37.9	3.86	2280	232	1.08	159	31.4	3.20	2150	219	1.08	08 -	6080	- 11	B-100	B-116	B-135		
			2280	232	1.41				2150	219	1.41				08 - 6085	- 11	B-100	B-116	B-135
			3340	340	2.09				3340	340	2.09				08 - 6090	- 11	B-100	B-116	B-135
			3340	340	2.76				3340	340	2.76				08 - 6095	- 11	B-100	B-116	B-135
112	44.7	4.56	2450	249	1.08	135	37.1	3.78	2310	235	1.08	08 -	6080	- 13	B-100	B-116	B-135		
			2450	249	1.41				2310	235	1.41				08 - 6085	- 13	B-100	B-116	B-135
			3340	340	2.09				3340	340	2.09				08 - 6090	- 13	B-100	B-116	B-135
			3340	340	2.76				3340	340	2.76				08 - 6095	- 13	B-100	B-116	B-135

1. Combinations in **bold** are the recommended models for operations for 10 hours/day with uniform load (service factor is about 1.0 for motor rating at 50Hz).
2. Motor slippage may affect n₁ and n₂. Refer to technical data for details.
3. CNHM, CHHM, CNFM, CHFM, CNVM, and CVVM indicate types. Refer to page B-10 for details.
4. Lubrication method is different for each model. Refer to "Lubrication" section in page F-4~F-5 for details.
5. "6" at the end of "input capacity symbol" indicates models with 6P motor. Other models come with 4P motor.

Selection Tables Gearmotors

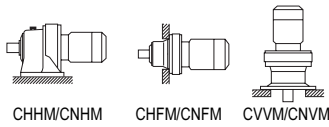

0.55 kW	Hz		50Hz		60Hz	
	P		4	6	4	6
	n ₁	r/min	1450	980	1750	1165

n₁: Motor Speed

50Hz						60Hz						Nomenclature			Page of Dimension Sheet					
Output Speed n ₂ r/min	Output Torque T _{out}		Allowable Radial Load Pro		SF	Output Speed n ₂ r/min	Output Torque T _{out}		Allowable Radial Load Pro		SF	Input Capacity Symbol	Frame Size	Reduction Ratio	CNHM	CNFM	CNVM			
	N·m	kgf·m	N	kgf			N·m	kgf·m	N	kgf								CHHM	CHFM	CVVM
96.7	51.6	5.26	2520	257	1.08	117	42.8	4.36	2380	242	1.08	08 -	6080	- 15	B-100	B-116	B-135			
			2520	257	1.41				2380	242	1.41				08 -	6085	- 15	B-100	B-116	B-135
			3340	340	2.09				3340	340	2.09				08 -	6090	- 15	B-100	B-116	B-135
			3340	340	2.76				3340	340	2.76				08 -	6095	- 15	B-100	B-116	B-135
85.3	58.5	5.96	2560	261	1.08	103	48.5	4.94	2490	254	1.08	08 -	6080	- 17	B-100	B-116	B-135			
			2560	261	1.41				2490	254	1.41				08 -	6085	- 17	B-100	B-116	B-135
			3340	340	2.09				3340	340	2.09				08 -	6090	- 17	B-100	B-116	B-135
			3340	340	2.76				3340	340	2.76				08 -	6095	- 17	B-100	B-116	B-135
69.0	72.3	7.37	2560	261	1.00	83.3	59.9	6.10	2430	247	1.00	08 -	6085	- 21	B-100	B-116	B-135			
			3340	340	1.38				3340	340	1.38				08 -	6090	- 21	B-100	B-116	B-135
			3340	340	2.75				3340	340	2.76				08 -	6095	- 21	B-100	B-116	B-135
58.0	86.0	8.77	2510	256	0.86	70.0	71.3	7.27	2490	254	0.86	08 -	6085	- 25	B-100	B-116	B-135			
			3340	340	1.22				3340	340	1.22				08 -	6090	- 25	B-100	B-116	B-135
			3340	340	1.57				3340	340	1.57				08 -	6095	- 25	B-100	B-116	B-135
			5400	550	2.31				5400	550	2.31				08 -	6100	- 25	B-101	B-117	B-136
50.0	99.8	10.2	2300	235	0.85	60.3	82.7	8.43	2480	253	0.85	08 -	6085	- 29	B-100	B-116	B-135			
			3340	340	1.14				3340	340	1.14				08 -	6090	- 29	B-100	B-116	B-135
			3340	340	1.43				3340	340	1.43				08 -	6095	- 29	B-100	B-116	B-135
			5400	550	2.20				5400	550	2.20				08 -	6100	- 29	B-101	B-117	B-136
41.4	120	12.3	3340	340	1.11	50.0	99.8	10.2	3340	340	1.11	08 -	6090	- 35	B-100	B-116	B-135			
			3340	340	1.38				3340	340	1.38				08 -	6095	- 35	B-100	B-116	B-135
			5400	550	1.77				5400	550	1.77				08 -	6100	- 35	B-101	B-117	B-136
			5400	550	2.18				5400	550	2.18				08 -	6105	- 35	B-101	B-117	B-136
33.7	148	15.1	3320	338	1.10	40.7	123	12.5	3340	340	1.10	08 -	6095	- 43	B-100	B-116	B-135			
			5400	550	1.42				5400	550	1.42				08 -	6100	- 43	B-101	B-117	B-136
			5400	550	1.96				5400	550	1.96				08 -	6105	- 43	B-101	B-117	B-136
			7610	776	2.36				7610	776	2.36				08 -	6110	- 43	B-101	B-117	B-136
28.4	176	17.9	5400	550	1.02	34.3	145	14.8	5400	550	1.02	08 -	6100	- 51	B-101	B-117	B-136			
			5400	550	1.41				5400	550	1.41				08 -	6105	- 51	B-101	B-117	B-136
			7610	776	1.72				7610	776	1.72				08 -	6110	- 51	B-101	B-117	B-136
			7610	776	2.02				7610	776	2.02				08 -	6115	- 51	B-101	B-117	B-136
24.6	203	20.7	9810	1000	2.96	29.7	168	17.1	9810	1000	3.13	08 -	6120	- 51	B-101	B-117	B-136			
			5400	550	1.24				5400	550	1.29				08 -	6105	- 59	B-101	B-117	B-136
			7610	776	1.56				7610	776	1.56				08 -	6110	- 59	B-101	B-117	B-136
			7610	776	1.84				7610	776	1.84				08 -	6115	- 59	B-101	B-117	B-136
20.4	244	24.9	9810	1000	2.36	24.6	202	20.6	9810	1000	2.36	08 -	6120	- 59	B-101	B-117	B-136			
			9810	1000	2.95				9810	1000	2.95				08 -	6125	- 59	B-101	B-117	B-136
			5380	549	0.92				5400	550	1.02				08 -	6105	- 71	B-101	B-117	B-136
			7610	776	1.22				7610	776	1.22				08 -	6110	- 71	B-101	B-117	B-136
16.7	299	30.5	7610	776	1.38	20.1	248	25.3	7610	776	1.38	08 -	6115	- 71	B-101	B-117	B-136			
			9810	1000	1.74				9810	1000	1.74				08 -	6120	- 71	B-101	B-117	B-136
			9810	1000	2.07				9810	1000	2.18				08 -	6125	- 71	B-101	B-117	B-136
			4800	489	0.91				5400	550	1.03				08 -	6105	- 87	B-101	B-117	B-136
16.7	299	30.5	7610	776	1.20	20.1	248	25.3	7610	776	1.20	08 -	6110	- 87	B-101	B-117	B-136			
			7610	776	1.38				7610	776	1.38				08 -	6115	- 87	B-101	B-117	B-136
			9810	1000	1.72				9810	1000	1.72				08 -	6120	- 87	B-101	B-117	B-136
			9810	1000	1.87				9810	1000	2.05				08 -	6125	- 87	B-101	B-117	B-136
			14700	1500	2.58				14200	1450	2.58				08 -	6130	- 87	B-102	B-118	B-137
14700	1500	3.00	14200	1450	3.47	08 -	6135	- 87	B-102	B-118	B-137									

GEARMOTORS
Selection Tables
0.55 kW

- "*2" indicate models manufactured with reducer and motor separately mounted on a common baseplate (horizontal shaft direction) or on an adaptor (vertical shaft direction). Consult us for details, including dimensions.
- Allowable radial load (Pro) is the value at the midpoint of the slow speed shaft.
- "*3" indicate models with reduction ratios equal to nominal ratio. Refer to Table A-3 "6000SK Series (Actual Reduction Ratio)" on page A-4 for actual reduction ratio. Indicated reduction ratio is the same as actual reduction ratio for other models.
- Maintain torque load during operation within "Output torque" in the table for models with "*" in the SF column. They cannot be operated with 100% motor rating.

Selection Tables Gearmotors

0.55 kW	Hz		50Hz		60Hz	
	P		4	6	4	6
	n ₁	r/min	1450	980	1750	1165

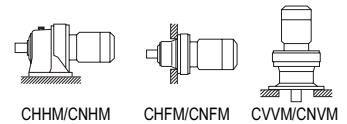

50Hz						60Hz						Nomenclature			Page of Dimension Sheet						
Output Speed n ₂ r/min	Output Torque Tout N·m kgf·m		Allowable Radial Load Pro N kgf		SF	Output Speed n ₂ r/min	Output Torque Tout N·m kgf·m		Allowable Radial Load Pro N kgf		SF	Input Capacity Symbol	Frame Size	Reduction Ratio	CNHM	CNFM	CNVM				
13.9	339	34.6	9810	1000	1.55	16.8	281	28.6	9810	1000	1.87	08 - 6120DB - 104	- 104	- 104	B-108	B-124	B-143				
			9810	1000	1.86				9810	1000	2.24				08 - 6125DB - 104	B-108	B-124	B-143			
			14700	1500	2.30				14700	1500	2.78				08 - 6130DB - 104	B-109	B-125	B-144			
			14700	1500	2.77				14700	1500	2.91				08 - 6135DB - 104	B-109	B-125	B-144			
			14700	1500	2.77				14700	1500	3.35				08 - 6135DC - 104	B-109	B-125	B-144			
			16000	1630	2.91				16000	1630	2.91				08 - 6140DB - 104	B-109	B-125	B-144			
12.0	394	40.2	9810	1000	1.33	14.5	327	33.3	9810	1000	1.61	08 - 6120DB - 121	- 121	- 121	B-108	B-124	B-143				
			9810	1000	1.58				9810	1000	1.90				08 - 6125DB - 121	B-108	B-124	B-143			
			14700	1500	1.98				14700	1500	2.39				08 - 6130DB - 121	B-109	B-125	B-144			
			14700	1500	2.38				14700	1500	2.88				08 - 6135DB - 121	B-109	B-125	B-144			
			16000	1630	2.91				16000	1630	2.91				08 - 6140DB - 121	B-109	B-125	B-144			
10.1	466	47.5	9810	1000	1.13	12.2	386	39.4	9810	1000	1.36	08 - 6120DB - 143	- 143	- 143	B-108	B-124	B-143				
			9810	1000	1.35				9810	1000	1.63				08 - 6125DB - 143	B-108	B-124	B-143			
			14700	1500	1.67				14700	1500	2.02				08 - 6130DB - 143	B-109	B-125	B-144			
			14700	1500	2.02				14700	1500	2.43				08 - 6135DB - 143	B-109	B-125	B-144			
			16000	1630	2.63				16000	1630	2.91				08 - 6140DB - 143	B-109	B-125	B-144			
			16000	1630	2.63				16000	1630	3.17				08 - 6140DC - 143	B-109	B-125	B-144			
			16000	1630	2.91				16000	1630	2.91				08 - 6145DB - 143	B-109	B-125	B-144			
			16000	1630	2.94				16000	1630	3.55				08 - 6145DC - 143	B-109	B-125	B-144			
8.79	538	54.8	9810	1000	1.17	10.6	446	45.4	9810	1000	1.41	08 - 6125DB - 165	- 165	- 165	B-108	B-124	B-143				
			14700	1500	1.45				14700	1500	1.75				08 - 6130DB - 165	B-109	B-125	B-144			
			14700	1500	1.75				14700	1500	2.11				08 - 6135DB - 165	B-109	B-125	B-144			
			16000	1630	2.28				16000	1630	2.75				08 - 6140DB - 165	B-109	B-125	B-144			
			16000	1630	2.52				16000	1630	2.91				08 - 6145DB - 165	B-109	B-125	B-144			
			16000	1630	2.52				16000	1630	3.05				08 - 6145DC - 165	B-109	B-125	B-144			
			22100	2250	2.91				22100	2250	2.91				08 - 6160DA - 165	B-110	B-126	B-145			
7.44	636	64.8	525	53.5	9810	1000	*1	8.97	527	53.7	525	53.5	9810	1000	*1	08 - 6120DB - 195	- 195	- 195	B-108	B-124	B-143
			9810	1000	0.98	9810	1000				1.20	08 - 6125DB - 195	B-108	B-124	B-143						
			14700	1500	1.23	14700	1500				1.48	08 - 6130DB - 195	B-109	B-125	B-144						
			14700	1500	1.48	14700	1500				1.78	08 - 6135DB - 195	B-109	B-125	B-144						
			16000	1630	1.93	16000	1630				2.33	08 - 6140DB - 195	B-109	B-125	B-144						
			16000	1630	2.14	16000	1630				2.58	08 - 6145DB - 195	B-109	B-125	B-144						
			22100	2250	2.76	22100	2250				2.91	08 - 6160DA - 195	B-110	B-126	B-145						
			22100	2250	2.76	22100	2250				3.33	08 - 6160DB - 195	B-110	B-126	B-145						
			22100	2250	2.91	22100	2250				2.91	08 - 6165DA - 195	B-110	B-126	B-145						
6.28	753	76.8	522	53.2	9810	1000	*1	7.58	624	63.6	522	53.2	9810	1000	*1	08 - 6120DB - 231	- 231	- 231	B-108	B-124	B-143
			9810	1000	0.84	9810	1000				1.01	08 - 6125DB - 231	B-108	B-124	B-143						
			14700	1500	1.04	14700	1500				1.25	08 - 6130DB - 231	B-109	B-125	B-144						
			14700	1500	1.25	14700	1500				1.51	08 - 6135DB - 231	B-109	B-125	B-144						
			16000	1630	1.63	16000	1630				1.96	08 - 6140DB - 231	B-109	B-125	B-144						
			16000	1630	1.78	16000	1630				2.14	08 - 6145DB - 231	B-109	B-125	B-144						
			22100	2250	2.33	22100	2250				2.81	08 - 6160DA - 231	B-110	B-126	B-145						
			22100	2250	2.79	22100	2250				2.91	08 - 6165DA - 231	B-110	B-126	B-145						
			22100	2250	2.79	22100	2250				3.37	08 - 6165DB - 231	B-110	B-126	B-145						
			29500	3010	2.91	29500	3010				2.91	08 - 6170DA - 231	B-110	B-126	B-145						

- Combinations in **bold** are the recommended models for operations for 10 hours/day with uniform load (service factor is about 1.0 for motor rating at 50Hz).
- Motor slippage may affect n₁ and n₂. Refer to technical data for details.
- CNHM, CHHM, CNFM, CHFM, CNVM, and CVVM indicate types. Refer to page B-10 for details.
- Lubrication method is different for each model. Refer to "Lubrication" section in page F-4~F-5 for details.
- "6" at the end of "input capacity symbol" indicates models with 6P motor. Other models come with 4P motor.

Selection Tables Gearmotors

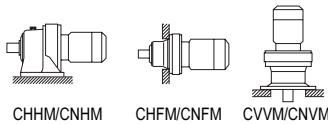

0.55 kW	Hz		50Hz		60Hz	
	P		4	6	4	6
	n ₁	r/min	1450	980	1750	1165

n₁: Motor Speed

50Hz					60Hz					Nomenclature			Page of Dimension Sheet									
Output Speed n ₂ r/min	Output Torque Tout		Allowable Radial Load Pro		SF	Output Speed n ₂ r/min	Output Torque Tout		Allowable Radial Load Pro		Input Capacity - Symbol	Frame Size - Ratio	Reduction Ratio	CNHM	CNFM	CNVM						
	N·m	kgf·m	N	kgf			N·m	kgf·m	N	kgf							CHHM	CHFM	CVVM			
5.31	890	90.7	14700	1500	1.06	6.41	737	75.2	14700	1500	1.27	08 - 6135DB	- 273	B-109	B-125	B-144						
			16000	1630	1.38				16000	1630	1.66	08 - 6140DB	- 273	B-109	B-125	B-144						
			16000	1630	1.50				16000	1630	1.81	08 - 6145DB	- 273	B-109	B-125	B-144						
			22100	2250	1.97				22100	2250	2.38	08 - 6160DA	- 273	B-110	B-126	B-145						
			22100	2250	2.36				22100	2250	2.85	08 - 6165DA	- 273	B-110	B-126	B-145						
			29500	3010	2.84				29500	3010	2.91	08 - 6170DA	- 273	B-110	B-126	B-145						
			29500	3010	2.84				29500	3010	3.43	08 - 6170DB	- 273	B-110	B-126	B-145						
4.55	1040	106	9810	1000	*1	5.49	862	87.8	9810	1000	*1	08 - 6125DB	- 319	B-108	B-124	B-143						
			14700	1500	0.90				14700	1500	*1	08 - 6130DB	- 319	B-109	B-125	B-144						
			16000	1630	1.18				14700	1500	1.09	08 - 6135DB	- 319	B-109	B-125	B-144						
			16000	1630	1.32				16000	1630	1.42	08 - 6140DB	- 319	B-109	B-125	B-144						
			22100	2250	1.69				16000	1630	1.59	08 - 6145DB	- 319	B-109	B-125	B-144						
			22100	2250	2.02				22100	2250	2.04	08 - 6160DA	- 319	B-110	B-126	B-145						
			29500	3010	2.43				22100	2250	2.44	08 - 6165DA	- 319	B-110	B-126	B-145						
3.85	1230	125	14700	1500	*1	4.64	1020	104	14700	1500	*1	08 - 6170DA	- 319	B-110	B-126	B-145						
			14700	1500	*1				29500	3010	2.91	08 - 6175DA	- 319	B-110	B-126	B-145						
			16000	1630	1.00				29500	3010	2.94	08 - 6170DB	- 319	B-110	B-126	B-145						
			16000	1630	1.11				29500	3010	2.91	08 - 6175DA	- 319	B-110	B-126	B-145						
			22100	2250	1.43				29500	3010	2.91	08 - 6175DB	- 377	B-109	B-125	B-144						
			22100	2250	1.71				16000	1630	1.20	08 - 6140DB	- 377	B-109	B-125	B-144						
			29500	3010	2.06				16000	1630	1.35	08 - 6145DB	- 377	B-109	B-125	B-144						
3.07	1540	157	14700	1500	*1	3.70	1280	130	14700	1500	*1	08 - 6160DA	- 377	B-110	B-126	B-145						
			16000	1630	1.11				16000	1630	1.36	08 - 6165DA	- 473	B-110	B-126	B-145						
			22100	2250	1.43				22100	2250	1.64	08 - 6170DA	- 473	B-110	B-126	B-145						
			22100	2250	1.36				29500	3010	1.98	08 - 6175DA	- 473	B-110	B-126	B-145						
			29500	3010	1.64				29500	3010	2.47	08 - 6175DB	- 473	B-110	B-126	B-145						
			29500	3010	2.04				16000	1630	1.07	08 - 6145DB	- 473	B-109	B-125	B-144						
			2.59	1820	186				14700	1500	*1	3.13	1510	154	14700	1500	*1	08 - 6160DA	- 559	B-110	B-126	B-145
16000	1630	*1				16000	1630	*1	08 - 6145DB	- 559	B-109				B-125	B-144						
16000	1630	*1				16000	1630	*1	08 - 6140DB	- 559	B-109				B-125	B-144						
22100	2250	1.15				22100	2250	1.39	08 - 6165DA	- 559	B-110				B-126	B-145						
29500	3010	1.39				22100	2250	1.68	08 - 6170DA	- 559	B-110				B-126	B-145						
29500	3010	1.73				29500	3010	2.09	08 - 6175DA	- 559	B-110				B-126	B-145						
2.23	2120	216				16000	1630	*1	2.70	1750	179				16000	1630	*1	08 - 6175DB	- 559	B-110	B-126	B-145
			22100	2250	*1	16000	1630	*1				08 - 6145DB	- 649	B-109	B-125	B-144						
			22100	2250	0.98	16000	1630	*1				08 - 6160DA	- 649	B-110	B-126	B-145						
			29500	3010	1.20	22100	2250	1.20				08 - 6165DA	- 649	B-110	B-126	B-145						
			29500	3010	1.49	29500	3010	1.44				08 - 6170DA	- 649	B-110	B-126	B-145						
			1.98	2380	243	22100	2250	*1				2.39	1970	201	22100	2250	*1	08 - 6175DA	- 649	B-110	B-126	B-145
						22100	2250	0.88							1740	177	22100	2250	*1	08 - 6160DA	- 731	B-110
29500	3010	1.06				22100	2250	1.06	08 - 6165DA	- 731	B-110				B-126	B-145						
29500	3010	1.32				29500	3010	1.28	08 - 6170DA	- 731	B-110				B-126	B-145						
29500	3010	1.60				29500	3010	1.60	08 - 6175DA	- 731	B-110				B-126	B-145						

GEARMOTORS
Selection Tables
0.55 kW

- "*2" indicate models manufactured with reducer and motor separately mounted on a common baseplate (horizontal shaft direction) or on an adaptor (vertical shaft direction). Consult us for details, including dimensions.
- Allowable radial load (Pro) is the value at the midpoint of the slow speed shaft.
- "*3" indicate models with reduction ratios equal to nominal ratio. Refer to Table A-3 "6000SK Series (Actual Reduction Ratio)" on page A-4 for actual reduction ratio. Indicated reduction ratio is the same as actual reduction ratio for other models.
- Maintain torque load during operation within "Output torque" in the table for models with "*" in the SF column. They cannot be operated with 100% motor rating.

Selection Tables Gearmotors

0.55 kW	Hz		50Hz		60Hz	
	P		4	6	4	6
	n ₁	r/min	1450	980	1750	1165

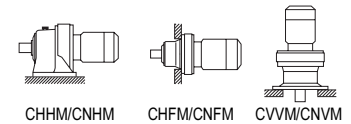

50Hz						60Hz						Nomenclature			Page of Dimension Sheet		
Output Speed n ₂	Output Torque Tout		Allowable Radial Load Pro		SF	Output Speed n ₂	Output Torque Tout		Allowable Radial Load Pro		SF	Input Capacity Symbol	Frame Size	Reduction Ratio	CNHM	CNFM	CNVM
r/min	N·m	kgf·m	N	kgf		r/min	N·m	kgf·m	N	kgf					CHHM	CHF	CVVM
1.72	1760	179	22100	2250	*1	2.08	1760	179	22100	2250	*1	08 -	6160DA	- 841	B-110	B-126	B-145
	2100	214	22100	2250	*1		2100	214	22100	2250	*1	08 -	6165DA	- 841	B-110	B-126	B-145
	2740	279	29500	3010	1.15		2270	232	29500	3010	1.39	08 -	6175DA	- 841	B-110	B-126	B-145
1.45	2100	214	22100	2250	*1	1.74	2100	214	22100	2250	*1	08 -	6165DA	- 1003	B-110	B-126	B-145
	2530	258	29500	3010	*1		2530	258	29500	3010	*1	08 -	6170DA	- 1003	B-110	B-126	B-145
	3270	333	29500	3010	0.96		2710	276	29500	3010	1.16	08 -	6175DA	- 1003	B-110	B-126	B-145
1.16	2530	258	29500	3010	*1	1.40	2530	258	29500	3010	*1	08 -	6170DA	- 1247	B-110	B-126	B-145
	3150	321	29500	3010	*1		3150	321	29500	3010	*1	08 -	6175DA	- 1247	B-110	B-126	B-145
0.980	3150	321	29500	3010	*1	1.18	3150	321	29500	3010	*1	08 -	6175DA	- 1479	B-110	B-126	B-145
0.784	4060	414	41700	4250	*1	0.946	4060	414	41700	4250	*1	08 -	6180DA	- 1849	B-110	B-126	B-145

Selection Tables
0.55 kW, 0.75 kW

0.75 kW	Hz		50Hz		60Hz	
	P		4	6	4	6
	n ₁	r/min	1450	980	1750	1165

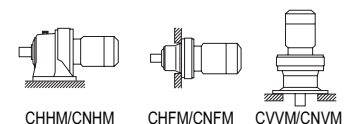

50Hz						60Hz						Nomenclature			Page of Dimension Sheet					
Output Speed n ₂	Output Torque Tout		Allowable Radial Load Pro		SF	Output Speed n ₂	Output Torque Tout		Allowable Radial Load Pro		SF	Input Capacity Symbol	Frame Size	Reduction Ratio	CNHM	CNFM	CNVM			
r/min	N·m	kgf·m	N	kgf		r/min	N·m	kgf·m	N	kgf					CHHM	CHF	CVVM			
580	11.7	1.20	1130	115	1.48	700	9.72	0.991	1080	110	1.48	1 -	6070SK	- 2.5 *3	B-98	-	B-133			
			1130	115	1.85				1080	110	1.85				1 -	6075SK	- 2.5 *3	B-98	-	B-133
			1260	128	2.20				1190	121	2.20				1 -	6080SK	- 2.5 *3	B-98	-	B-133
			1260	128	2.75				1190	121	2.75				1 -	6085SK	- 2.5 *3	B-98	-	B-133
			2250	229	3.20				2130	217	3.20				1 -	6090SK	- 2.5 *3	B-98	-	B-133
2250	229	3.61	2130	217	3.61	1 -	6095SK	- 2.5 *3	B-98	-	B-133									
483	14.1	1.44	1180	120	1.41	583	11.7	1.19	1120	114	1.41	1 -	6070SK	- 3 *3	B-98	-	B-133			
			1180	120	1.77				1120	114	1.77				1 -	6075SK	- 3 *3	B-98	-	B-133
			1310	134	2.20				1250	127	2.20				1 -	6080SK	- 3 *3	B-98	-	B-133
			1310	134	2.75				1250	127	2.75				1 -	6085SK	- 3 *3	B-98	-	B-133
			2340	239	3.12				2220	226	3.12				1 -	6090SK	- 3 *3	B-98	-	B-133
2340	239	3.51	2220	226	3.51	1 -	6095SK	- 3 *3	B-98	-	B-133									
363	18.8	1.91	1270	129	1.25	438	15.6	1.59	1220	124	1.25	1 -	6070SK	- 4 *3	B-98	-	B-133			
			1270	129	1.56				1220	124	1.56				1 -	6075SK	- 4 *3	B-98	-	B-133
			1420	145	2.20				1350	138	2.20				1 -	6080SK	- 4 *3	B-98	-	B-133
			1420	145	2.75				1350	138	2.75				1 -	6085SK	- 4 *3	B-98	-	B-133
			2660	271	3.12				2520	257	3.12				1 -	6090SK	- 4 *3	B-98	-	B-133
2660	271	3.51	2520	257	3.51	1 -	6095SK	- 4 *3	B-98	-	B-133									
290	23.5	2.39	1370	140	1.18	350	19.4	1.98	1290	132	1.18	1 -	6070SK	- 5 *3	B-98	-	B-133			
			1370	140	1.48				1290	132	1.48				1 -	6075SK	- 5 *3	B-98	-	B-133
			1530	156	2.07				1460	149	2.07				1 -	6080SK	- 5 *3	B-98	-	B-133
			1530	156	2.47				1460	149	2.43				1 -	6085SK	- 5 *3	B-98	-	B-133
			2820	287	2.98				2680	273	2.98				1 -	6090SK	- 5 *3	B-98	-	B-133
2820	287	3.51	2680	273	3.51	1 -	6095SK	- 5 *3	B-98	-	B-133									

1. Combinations in **bold** are the recommended models for operations for 10 hours/day with uniform load (service factor is about 1.0 for motor rating at 50Hz).
2. Motor slippage may affect n₁ and n₂. Refer to technical data for details.
3. CNHM, CHHM, CNFM, CHF, CNVM, and CVVM indicate types. Refer to page B-10 for details.
4. Lubrication method is different for each model. Refer to "Lubrication" section in page F-4~F-5 for details.
5. "6" at the end of "input capacity symbol" indicates models with 6P motor. Other models come with 4P motor.

Selection Tables Gearmotors

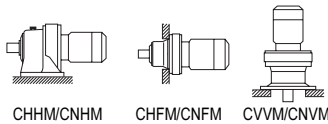

0.75 kW	Hz		50Hz		60Hz	
	P		4	6	4	6
	n ₁	r/min	1450	980	1750	1165

n₁: Motor Speed

50Hz					60Hz					Nomenclature			Page of Dimension Sheet			
Output Speed n ₂ r/min	Output Torque Tout		Allowable Radial Load Pro		SF	Output Speed n ₂ r/min	Output Torque Tout		Allowable Radial Load Pro		Input Capacity Symbol	Frame Size	Reduction Ratio	CNHM	CNFM	CNVM
	N·m	kgf·m	N	kgf			N·m	kgf·m	N	kgf						
242	28.2	2.87	1370	140	1.04	292	23.3	2.38	1290	132	1.04	1 - 6070SK	- 6 *3	B-98	-	B-133
			1370	140	1.30				1290	132	1.30	1 - 6075SK	- 6 *3	B-98	-	B-133
			1580	161	1.73				1520	155	1.73	1 - 6080SK	- 6 *3	B-98	-	B-133
			1580	161	2.16				1520	155	2.16	1 - 6085SK	- 6 *3	B-98	-	B-133
			2880	294	2.55				2750	280	2.55	1 - 6090SK	- 6 *3	B-98	-	B-133
			2880	294	3.03				2750	280	3.03	1 - 6095SK	- 6 *3	B-98	-	B-133
			2880	294	3.56				2750	280	3.56	1 - 6100SK	- 6 *3	B-99	-	B-134
			1900	193	1.04				1790	182	1.04	1 - 6085	- 6	B-100	B-116	B-135
			2840	290	1.53				2670	273	1.53	1 - 6090	- 6	B-100	B-116	B-135
			2840	290	2.03				2670	273	2.03	1 - 6095	- 6	B-100	B-116	B-135
181	37.5	3.83	1510	154	0.98	219	31.1	3.17	1420	145	0.98	1 - 6075SK	- 8 *3	B-98	-	B-133
			1660	169	1.46				1590	162	1.46	1 - 6080SK	- 8 *3	B-98	-	B-133
			1660	169	1.83				1590	162	1.83	1 - 6085SK	- 8 *3	B-98	-	B-133
			3210	327	2.01				3060	312	2.01	1 - 6090SK	- 8 *3	B-98	-	B-133
			3210	327	2.36				3060	312	2.36	1 - 6095SK	- 8 *3	B-98	-	B-133
			3210	327	2.82				3060	312	2.82	1 - 6100SK	- 8 *3	B-99	-	B-134
			3210	327	3.32				3060	312	3.32	1 - 6105SK	- 8 *3	B-99	-	B-134
			2050	209	1.04				1930	197	1.04	1 - 6085	- 8	B-100	B-116	B-135
			3160	322	1.53				2980	304	1.53	1 - 6090	- 8	B-100	B-116	B-135
			3160	322	2.03				2980	304	2.03	1 - 6095	- 8	B-100	B-116	B-135
145	46.9	4.78	1740	177	1.17	175	38.9	3.96	1680	171	1.17	1 - 6080SK	- 10 *3	B-98	-	B-133
			1740	177	1.47				1680	171	1.47	1 - 6085SK	- 10 *3	B-98	-	B-133
			3380	345	1.87				3240	330	1.87	1 - 6090SK	- 10 *3	B-98	-	B-133
			3380	345	2.36				3240	330	2.36	1 - 6095SK	- 10 *3	B-98	-	B-133
			3380	345	2.64				3240	330	2.64	1 - 6100SK	- 10 *3	B-99	-	B-134
			3380	345	2.93				3240	330	2.93	1 - 6105SK	- 10 *3	B-99	-	B-134
132	51.6	5.26	2250	230	1.04	159	42.8	4.36	2130	217	1.04	1 - 6085	- 11	B-100	B-116	B-135
			3340	340	1.53				3340	340	1.53	1 - 6090	- 11	B-100	B-116	B-135
			3340	340	2.03				3340	340	2.03	1 - 6095	- 11	B-100	B-116	B-135
112	61.0	6.22	2410	246	1.04	135	50.5	5.15	2280	233	1.04	1 - 6085	- 13	B-100	B-116	B-135
			3340	340	1.53				3340	340	1.53	1 - 6090	- 13	B-100	B-116	B-135
			3340	340	2.03				3340	340	2.03	1 - 6095	- 13	B-100	B-116	B-135
96.7	70.4	7.18	2490	253	1.04	117	58.3	5.95	2350	240	1.04	1 - 6085	- 15	B-100	B-116	B-135
			3340	340	1.53				3340	340	1.53	1 - 6090	- 15	B-100	B-116	B-135
			3340	340	2.03				3340	340	2.03	1 - 6095	- 15	B-100	B-116	B-135
85.3	79.8	8.13	2560	261	1.04	103	66.1	6.74	2460	251	1.04	1 - 6085	- 17	B-100	B-116	B-135
			3340	340	1.53				3340	340	1.53	1 - 6090	- 17	B-100	B-116	B-135
			3340	340	2.03				3340	340	2.03	1 - 6095	- 17	B-100	B-116	B-135
			5400	550	2.65				5400	550	2.65	1 - 6100	- 17	B-101	B-117	B-136
69.0	98.5	10.0	3340	340	1.01	83.3	81.7	8.32	3340	340	1.01	1 - 6090	- 21	B-100	B-116	B-135
			3340	340	2.01				3340	340	2.03	1 - 6095	- 21	B-100	B-116	B-135
			5400	550	2.53				5400	550	2.57	1 - 6100	- 21	B-101	B-117	B-136
58.0	117	12.0	3340	340	1.15	70.0	97.2	9.91	3340	340	1.15	1 - 6095	- 25	B-100	B-116	B-135
			5400	550	1.69				5400	550	1.69	1 - 6100	- 25	B-101	B-117	B-136
			5400	550	2.23				5400	550	2.23	1 - 6105	- 25	B-101	B-117	B-136
			7240	738	2.55				6810	694	2.55	1 - 6110	- 25	B-101	B-117	B-136
			7240	738	2.96				6810	694	2.96	1 - 6115	- 25	B-101	B-117	B-136
50.0	136	13.9	3320	338	1.05	60.3	113	11.5	3340	340	1.05	1 - 6095	- 29	B-100	B-116	B-135
			5400	550	1.61				5400	550	1.61	1 - 6100	- 29	B-101	B-117	B-136
			5400	550	2.12				5400	550	2.12	1 - 6105	- 29	B-101	B-117	B-136
			7410	756	2.53				7000	714	2.53	1 - 6110	- 29	B-101	B-117	B-136
			7410	756	2.96				7000	714	2.96	1 - 6115	- 29	B-101	B-117	B-136

GEARMOTORS
Selection Tables
0.75 kW

- "*2" indicate models manufactured with reducer and motor separately mounted on a common baseplate (horizontal shaft direction) or on an adaptor (vertical shaft direction). Consult us for details, including dimensions.
- Allowable radial load (Pro) is the value at the midpoint of the slow speed shaft.
- "*3" indicate models with reduction ratios equal to nominal ratio. Refer to Table A-3 "6000SK Series (Actual Reduction Ratio)" on page A-4 for actual reduction ratio. Indicated reduction ratio is the same as actual reduction ratio for other models.
- Maintain torque load during operation within "Output torque" in the table for models with "*"1" in the SF column. They cannot be operated with 100% motor rating.

Selection Tables Gearmotors

0.75 kW	Hz		50Hz		60Hz	
	P		4	6	4	6
	n ₁	r/min	1450	980	1750	1165

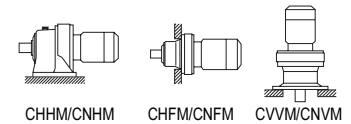

GEARMOTORS
Selection Tables
1.1 kW

50Hz						60Hz						Nomenclature			Page of Dimension Sheet					
Output Speed n ₂ r/min	Output Torque Tout N·m kgf·m		Allowable Radial Load Pro N kgf		SF	Output Speed n ₂ r/min	Output Torque Tout N·m kgf·m		Allowable Radial Load Pro N kgf		SF	Input Capacity Symbol	Frame Size	Reduction Ratio	CNHM CHHM	CNFM CHFM	CNVM CVVM			
41.4	164	16.7	3270	334	1.01	50.0	136	13.9	3330	339	1.01	1 -	6095	- 35	B-100	B-116	B-135			
			5400	550	1.30				5400	550	1.30				1 -	6100	- 35	B-101	B-117	B-136
			5400	550	1.60				5400	550	1.60				1 -	6105	- 35	B-101	B-117	B-136
			7470	761	2.00				7490	764	2.00				1 -	6110	- 35	B-101	B-117	B-136
			7470	761	2.41				7490	764	2.41				1 -	6115	- 35	B-101	B-117	B-136
33.7	202	20.6	3210	328	0.80	40.7	167	17.0	3280	334	0.80	1 -	6095	- 43	B-100	B-116	B-135			
			5400	550	1.04				5400	550	1.04				1 -	6100	- 43	B-101	B-117	B-136
			5400	550	1.44				5400	550	1.44				1 -	6105	- 43	B-101	B-117	B-136
			7610	776	1.73				7610	776	1.73				1 -	6110	- 43	B-101	B-117	B-136
			7610	776	2.03				7610	776	2.03				1 -	6115	- 43	B-101	B-117	B-136
28.4	239	24.4	9810	1000	2.55	34.3	198	20.2	9640	983	2.55	1 -	6120	- 43	B-101	B-117	B-136			
			5400	550	1.03				5390	549	1.03				1 -	6105	- 51	B-101	B-117	B-136
			7610	776	1.26				7610	776	1.26				1 -	6110	- 51	B-101	B-117	B-136
			7610	776	1.48				7610	776	1.48				1 -	6115	- 51	B-101	B-117	B-136
			9810	1000	2.17				9810	1000	2.29				1 -	6120	- 51	B-101	B-117	B-136
24.6	277	28.2	9810	1000	2.63	29.7	229	23.4	9810	1000	3.04	1 -	6125	- 51	B-101	B-117	B-136			
			5400	550	0.91				5370	548	0.94				1 -	6105	- 59	B-101	B-117	B-136
			7610	776	1.15				7610	776	1.15				1 -	6110	- 59	B-101	B-117	B-136
			7610	776	1.35				7610	776	1.35				1 -	6115	- 59	B-101	B-117	B-136
			9810	1000	1.73				9810	1000	1.73				1 -	6120	- 59	B-101	B-117	B-136
20.4	333	34.0	9810	1000	2.16	24.6	276	28.1	9810	1000	2.16	1 -	6125	- 59	B-101	B-117	B-136			
			13200	1340	2.81				12400	1270	2.92				1 -	6130	- 59	B-102	B-118	B-137
			7610	775	1.01				7610	776	1.01				1 -	6115	- 71	B-101	B-117	B-136
			9810	1000	1.28				9810	1000	1.28				1 -	6120	- 71	B-101	B-117	B-136
			9810	1000	1.52				9810	1000	1.60				1 -	6125	- 71	B-101	B-117	B-136
16.7	408	41.6	14000	1420	2.35	20.1	338	34.5	13100	1340	2.44	1 -	6135	- 71	B-102	B-118	B-137			
			14000	1420	2.71				13100	1340	2.89				1 -	6135	- 71	B-102	B-118	B-137
			7550	770	1.01				7610	776	1.01				1 -	6115	- 87	B-101	B-117	B-136
			9810	1000	1.26				9810	1000	1.26				1 -	6120	- 87	B-101	B-117	B-136
			9810	1000	1.37				9810	1000	1.51				1 -	6125	- 87	B-101	B-117	B-136
13.9	462	47.1	14700	1500	1.89	16.8	383	39.1	14200	1440	1.89	1 -	6130	- 87	B-102	B-118	B-137			
			14700	1500	2.20				14200	1440	2.55				1 -	6135	- 87	B-102	B-118	B-137
			16000	1630	2.64				16000	1630	2.64				1 -	6140	- 87	B-102	B-118	B-137
			16000	1630	2.88				16000	1630	3.31				1 -	6145	- 87	B-102	B-118	B-137
			9810	1000	1.14				9810	1000	1.37				1 -	6120DB	- 104	B-108	B-124	B-143
12.0	538	54.8	9810	1000	1.36	14.5	446	45.4	9810	1000	1.64	1 -	6125DB	- 104	B-108	B-124	B-143			
			14700	1500	1.69				14700	1500	2.04				1 -	6130DB	- 104	B-109	B-125	B-144
			14700	1500	2.03				14700	1500	2.13				1 -	6135DB	- 104	B-109	B-125	B-144
			14700	1500	2.03				14700	1500	2.45				1 -	6135DC	- 104	B-109	B-125	B-144
			16000	1630	2.13				16000	1630	2.13				1 -	6140DB	- 104	B-109	B-125	B-144
12.0	538	54.8	16000	1630	2.65	14.5	446	45.4	16000	1630	3.20	1 -	6140DC	- 104	B-109	B-125	B-144			
			16000	1630	2.96				16000	1630	3.58				1 -	6145DC	- 104	B-109	B-125	B-144
			9810	1000	1.16				9810	1000	1.40				1 -	6125DB	- 121	B-108	B-124	B-143
			14700	1500	1.45				14700	1500	1.75				1 -	6130DB	- 121	B-109	B-125	B-144
			14700	1500	1.75				14700	1500	2.11				1 -	6135DB	- 121	B-109	B-125	B-144
12.0	538	54.8	16000	1630	2.13	14.5	446	45.4	16000	1630	2.13	1 -	6140DB	- 121	B-109	B-125	B-144			
			16000	1630	2.28				16000	1630	2.75				1 -	6140DC	- 121	B-109	B-125	B-144
			16000	1630	2.28				16000	1630	2.75				1 -	6140DC	- 121	B-109	B-125	B-144
			16000	1630	2.40				16000	1630	2.90				1 -	6145DC	- 121	B-109	B-125	B-144

1. Combinations in **bold** are the recommended models for operations for 10 hours/day with uniform load (service factor is about 1.0 for motor rating at 50Hz).
2. Motor slippage may affect n₁ and n₂. Refer to technical data for details.
3. CNHM, CHHM, CNFM, CHFM, CNVM, and CVVM indicate types. Refer to page B-10 for details.
4. Lubrication method is different for each model. Refer to "Lubrication" section in page F-4~F-5 for details.
5. "6" at the end of "input capacity symbol" indicates models with 6P motor. Other models come with 4P motor.

Selection Tables Gearmotors

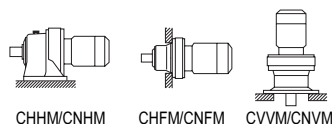

0.75 kW	Hz		50Hz		60Hz	
	P		4	6	4	6
	n ₁	r/min	1450	980	1750	1165

n₁: Motor Speed

50Hz					60Hz					Nomenclature			Page of Dimension Sheet					
Output Speed n ₂ r/min	Output Torque Tout		Allowable Radial Load Pro		SF	Output Speed n ₂ r/min	Output Torque Tout		Allowable Radial Load Pro		SF	Input Capacity - Symbol	Frame Size - -	Reduction Ratio - -	CNHM	CNFM	CNVM	
	N·m	kgf·m	N	kgf			N·m	kgf·m	N	kgf								CHHM
10.1	525	53.5	9810	1000	*1	12.2	525	53.5	9810	1000	*1	1 - 6120DB	- 143		B-108	B-124	B-143	
			9810	1000	0.98				9810	1000	1.20	1 - 6125DB	- 143		B-108	B-124	B-143	
	636	64.8	14700	1500	1.23		14700	1500	1.48	1 - 6130DB	- 143		1 - 6130DB	- 143		B-109	B-125	B-144
			14700	1500	1.48		14700	1500	1.78	1 - 6135DB	- 143		1 - 6135DB	- 143		B-109	B-125	B-144
			16000	1630	1.93		16000	1630	2.13	1 - 6140DB	- 143		1 - 6140DB	- 143		B-109	B-125	B-144
			16000	1630	1.93		16000	1630	2.33	1 - 6140DC	- 143		1 - 6140DC	- 143		B-109	B-125	B-144
			16000	1630	2.13		16000	1630	2.13	1 - 6145DB	- 143		1 - 6145DB	- 143		B-109	B-125	B-144
			16000	1630	2.15		16000	1630	2.60	1 - 6145DC	- 143		1 - 6145DC	- 143		B-109	B-125	B-144
			22100	2250	2.76		22100	2250	3.33	1 - 6160DB	- 143		1 - 6160DB	- 143		B-110	B-126	B-145
			22100	2250	2.76		22100	2250	3.33	1 - 6160DB	- 143		1 - 6160DB	- 143		B-110	B-126	B-145
8.79	525	53.5	9810	1000	*1	10.6	525	53.5	9810	1000	*1	1 - 6120DB	- 165		B-108	B-124	B-143	
			9810	1000	0.86				9810	1000	1.04	1 - 6125DB	- 165		B-108	B-124	B-143	
	734	74.8	14700	1500	1.06		14700	1500	1.28	1 - 6130DB	- 165		1 - 6130DB	- 165		B-109	B-125	B-144
			14700	1500	1.28		14700	1500	1.55	1 - 6135DB	- 165		1 - 6135DB	- 165		B-109	B-125	B-144
			16000	1630	1.67		16000	1630	2.02	1 - 6140DB	- 165		1 - 6140DB	- 165		B-109	B-125	B-144
			16000	1630	1.85		16000	1630	2.13	1 - 6145DB	- 165		1 - 6145DB	- 165		B-109	B-125	B-144
			16000	1630	1.85		16000	1630	2.23	1 - 6145DC	- 165		1 - 6145DC	- 165		B-109	B-125	B-144
			22100	2250	2.13		22100	2250	2.13	1 - 6160DA	- 165		1 - 6160DA	- 165		B-110	B-126	B-145
			22100	2250	2.39		22100	2250	2.89	1 - 6160DB	- 165		1 - 6160DB	- 165		B-110	B-126	B-145
			22100	2250	2.86		22100	2250	3.46	1 - 6165DB	- 165		1 - 6165DB	- 165		B-110	B-126	B-145
7.44	630	64.2	9810	1000	*1	8.97	630	64.2	9810	1000	*1	1 - 6125DB	- 195		B-108	B-124	B-143	
			14700	1500	1.08				14700	1500	1.31	1 - 6135DB	- 195		1 - 6135DB	- 195		B-109
	867	88.4	16000	1630	1.41		16000	1630	1.71	1 - 6140DB	- 195		1 - 6140DB	- 195		B-109	B-125	B-144
			16000	1630	1.57		16000	1630	1.89	1 - 6145DB	- 195		1 - 6145DB	- 195		B-109	B-125	B-144
			22100	2250	2.02		22100	2250	2.13	1 - 6160DA	- 195		1 - 6160DA	- 195		B-110	B-126	B-145
			22100	2250	2.02		22100	2250	2.44	1 - 6160DB	- 195		1 - 6160DB	- 195		B-110	B-126	B-145
			22100	2250	2.13		22100	2250	2.13	1 - 6165DA	- 195		1 - 6165DA	- 195		B-110	B-126	B-145
			22100	2250	2.42		22100	2250	2.92	1 - 6165DB	- 195		1 - 6165DB	- 195		B-110	B-126	B-145
			29500	3010	2.92		29500	3010	3.52	1 - 6170DB	- 195		1 - 6170DB	- 195		B-110	B-126	B-145
			6.28	630	64.2		9810	1000	*1	7.58	630	64.2	9810	1000	*1	1 - 6125DB	- 231	
14700	1500	0.92				14700	1500	1.10	1 - 6135DB				- 231		1 - 6135DB	- 231		B-109
1030	105	16000		1630	1.19	16000	1630	1.44	1 - 6140DB		- 231		1 - 6140DB	- 231		B-109	B-125	B-144
		16000		1630	1.30	16000	1630	1.57	1 - 6145DB		- 231		1 - 6145DB	- 231		B-109	B-125	B-144
		22100		2250	1.71	22100	2250	2.06	1 - 6160DA		- 231		1 - 6160DA	- 231		B-110	B-126	B-145
		22100		2250	2.04	22100	2250	2.13	1 - 6165DA		- 231		1 - 6165DA	- 231		B-110	B-126	B-145
		22100		2250	2.04	22100	2250	2.47	1 - 6165DB		- 231		1 - 6165DB	- 231		B-110	B-126	B-145
		29500		3010	2.13	29500	3010	2.13	1 - 6170DA		- 231		1 - 6170DA	- 231		B-110	B-126	B-145
		29500		3010	2.46	29500	3010	2.97	1 - 6170DB		- 231		1 - 6170DB	- 231		B-110	B-126	B-145
		5.31		780	79.5	14700	1500	*1	6.41		780	79.5	14700	1500	*1	1 - 6130DB	- 273	
14700	1500		*1			14700	1500	*1		1 - 6135DB			- 273		1 - 6135DB	- 273		B-109
1210	124		16000	1630	1.01	16000	1630	1.22		1 - 6140DB	- 273		1 - 6140DB	- 273		B-109	B-125	B-144
			16000	1630	1.10	16000	1630	1.33		1 - 6145DB	- 273		1 - 6145DB	- 273		B-109	B-125	B-144
			22100	2250	1.45	22100	2250	1.75		1 - 6160DA	- 273		1 - 6160DA	- 273		B-110	B-126	B-145
			22100	2250	1.73	22100	2250	2.09		1 - 6165DA	- 273		1 - 6165DA	- 273		B-110	B-126	B-145
			29500	3010	2.08	29500	3010	2.13		1 - 6170DA	- 273		1 - 6170DA	- 273		B-110	B-126	B-145
			29500	3010	2.08	29500	3010	2.52		1 - 6170DB	- 273		1 - 6170DB	- 273		B-110	B-126	B-145
			29500	3010	2.13	29500	3010	2.13		1 - 6175DA	- 273		1 - 6175DA	- 273		B-110	B-126	B-145
			29500	3010	2.60	29500	3010	3.13		1 - 6175DB	- 273		1 - 6175DB	- 273		B-110	B-126	B-145

GEARMOTORS
Selection Tables
1.5 kW

- "*2" indicate models manufactured with reducer and motor separately mounted on a common baseplate (horizontal shaft direction) or on an adaptor (vertical shaft direction). Consult us for details, including dimensions.
- Allowable radial load (Pro) is the value at the midpoint of the slow speed shaft.
- "*3" indicate models with reduction ratios equal to nominal ratio. Refer to Table A-3 "6000SK Series (Actual Reduction Ratio)" on page A-4 for actual reduction ratio. Indicated reduction ratio is the same as actual reduction ratio for other models.
- Maintain torque load during operation within "Output torque" in the table for models with "*" in the SF column. They cannot be operated with 100% motor rating.

Selection Tables Gearmotors

0.75 kW	Hz		50Hz		60Hz	
	P		4	6	4	6
	n ₁	r/min	1450	980	1750	1165

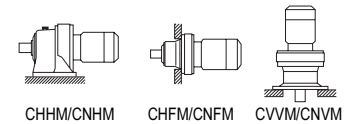

50Hz					60Hz					Nomenclature			Page of Dimension Sheet				
Output Speed n ₂ r/min	Output Torque Tout		Allowable Radial Load Pro		SF	Output Speed n ₂ r/min	Output Torque Tout		Allowable Radial Load Pro		SF	Input Capacity Symbol	Frame Size	Reduction Ratio	CNHM	CNFM	CNVM
	N·m	kgf·m	N	kgf			N·m	kgf·m	N	kgf							
4.55	940	95.8	14700	1500	*1	5.49	940	95.8	14700	1500	*1	1 - 6135DB	- 319	B-109	B-125	B-144	
			15500	1580	0.97				16000	1630	1.17	1 - 6145DB	- 319	B-109	B-125	B-144	
	22100	2250	1.24	22100	2250		1.49	1 - 6160DA	- 319	B-110	B-126	B-145					
	22100	2250	1.48	22100	2250		1.79	1 - 6165DA	- 319	B-110	B-126	B-145					
	29500	3010	1.78	29500	3010		2.13	1 - 6170DA	- 319	B-110	B-126	B-145					
	29500	3010	1.78	29500	3010		2.15	1 - 6170DB	- 319	B-110	B-126	B-145					
	29500	3010	2.13	29500	3010		2.13	1 - 6175DA	- 319	B-110	B-126	B-145					
	29500	3010	2.22	29500	3010		2.68	1 - 6175DB	- 319	B-110	B-126	B-145					
41700	4250	2.86	41700	4250	3.45	1 - 6180DA	- 319	B-110	B-126	B-145							
3.85	1230	125	16000	1630	*1	4.64	1230	125	16000	1630	*1	1 - 6140DB	- 377	B-109	B-125	B-144	
			15800	1610	*1				15800	1610	*1	1 - 6145DB	- 377	B-109	B-125	B-144	
	14100	1440	0.82	15700	1600		0.98	1 - 6145DB	- 377	B-109	B-125	B-144					
	22100	2250	1.05	22100	2250		1.26	1 - 6160DA	- 377	B-110	B-126	B-145					
	22100	2250	1.25	22100	2250		1.51	1 - 6165DA	- 377	B-110	B-126	B-145					
	29500	3010	1.51	29500	3010		1.82	1 - 6170DA	- 377	B-110	B-126	B-145					
	29500	3010	1.88	29500	3010		2.13	1 - 6175DA	- 377	B-110	B-126	B-145					
	29500	3010	1.88	29500	3010		2.27	1 - 6175DB	- 377	B-110	B-126	B-145					
41700	4250	2.42	41700	4250	2.92	1 - 6180DA	- 377	B-110	B-126	B-145							
41700	4250	2.98	41700	4250	3.60	1 - 6185DA	- 377	B-110	B-126	B-145							
3.07	1370	140	15700	1600	*1	3.70	1370	140	15700	1600	*1	1 - 6145DB	- 473	B-109	B-125	B-144	
			22100	2250	*1				22100	2250	*1	1 - 6160DA	- 473	B-110	B-126	B-145	
	29500	3010	1.20	22100	2250		1.21	1 - 6165DA	- 473	B-110	B-126	B-145					
	29500	3010	1.50	29500	3010		1.45	1 - 6170DA	- 473	B-110	B-126	B-145					
	2100	214	29500	3010	1.81		1 - 6175DA	- 473	B-110	B-126	B-145						
	41700	4250	1.93	41700	4250		2.33	1 - 6180DA	- 473	B-110	B-126	B-145					
41700	4250	2.38	41700	4250	2.87	1 - 6185DA	- 473	B-110	B-126	B-145							
2.59	1740	177	22100	2250	*1	3.13	1740	177	22100	2250	*1	1 - 6160DA	- 559	B-110	B-126	B-145	
			22100	2250	0.85				22100	2250	1.02	1 - 6165DA	- 559	B-110	B-126	B-145	
	29500	3010	1.02	29500	3010		1.23	1 - 6170DA	- 559	B-110	B-126	B-145					
	29500	3010	1.27	29500	3010		1.53	1 - 6175DA	- 559	B-110	B-126	B-145					
	41700	4250	1.63	41700	4250		1.97	1 - 6180DA	- 559	B-110	B-126	B-145					
	41700	4250	2.01	41700	4250		2.43	1 - 6185DA	- 559	B-110	B-126	B-145					
59000	6010	2.57	59000	6010	3.10	1 - 6190DA	- 559	B-111	B-128	B-147							
2.23	2100	214	22100	2250	*1	2.70	2100	214	22100	2250	*1	1 - 6165DA	- 649	B-110	B-126	B-145	
			29500	3010	1.09				29500	3010	1.32	1 - 6175DA	- 649	B-110	B-126	B-145	
	41700	4250	1.40	41700	4250		1.69	1 - 6180DA	- 649	B-110	B-126	B-145					
	41700	4250	1.73	41700	4250		2.09	1 - 6185DA	- 649	B-110	B-126	B-145					
	59000	6010	2.21	59000	6010		2.67	1 - 6190DA	- 649	B-111	B-128	B-147					
	59000	6010	2.76	59000	6010		3.33	1 - 6195DA	- 649	B-111	B-128	B-147					
1.98	2100	214	22100	2250	*1	2.39	2100	214	22100	2250	*1	1 - 6165DA	- 731	B-110	B-126	B-145	
			29500	3010	*1				29500	3010	*1	1 - 6170DA	- 731	B-110	B-126	B-145	
	29500	3010	0.97	29500	3010		1.17	1 - 6175DA	- 731	B-110	B-126	B-145					
	41700	4250	1.25	41700	4250		1.51	1 - 6180DA	- 731	B-110	B-126	B-145					
	41700	4250	1.54	41700	4250		1.86	1 - 6185DA	- 731	B-110	B-126	B-145					
	59000	6010	1.96	59000	6010		2.37	1 - 6190DA	- 731	B-111	B-128	B-147					
59000	6010	2.45	59000	6010	2.96	1 - 6195DA	- 731	B-111	B-128	B-147							
1.72	2530	258	29500	3010	*1	2.08	2530	258	29500	3010	*1	1 - 6170DA	- 841	B-110	B-126	B-145	
			29500	3010	0.84				29500	3010	1.02	1 - 6175DA	- 841	B-110	B-126	B-145	
	41700	4250	1.08	41700	4250		1.31	1 - 6180DA	- 841	B-110	B-126	B-145					
	41700	4250	1.34	41700	4250		1.61	1 - 6185DA	- 841	B-110	B-126	B-145					
	59000	6010	1.71	59000	6010		2.06	1 - 6190DA	- 841	B-111	B-128	B-147					
	59000	6010	2.13	59000	6010		2.57	1 - 6195DA	- 841	B-111	B-128	B-147					
1.45	3150	321	29500	3010	*1	1.74	3150	321	29500	3010	*1	1 - 6175DA	- 1003	B-110	B-126	B-145	
			41700	4250	1.12				41700	4250	1.35	1 - 6185DA	- 1003	B-110	B-126	B-145	
	4460	455	59000	6010	1.43		1 - 6190DA	- 1003	B-111	B-128	B-147						
	59000	6010	1.79	59000	6010		2.15	1 - 6195DA	- 1003	B-111	B-128	B-147					

1. Combinations in **bold** are the recommended models for operations for 10 hours/day with uniform load (service factor is about 1.0 for motor rating at 50Hz).
2. Motor slippage may affect n₁ and n₂. Refer to technical data for details.
3. CNHM, CHHM, CNFM, CHFM, CNVM, and CVVM indicate types. Refer to page B-10 for details.
4. Lubrication method is different for each model. Refer to "Lubrication" section in page F-4~F-5 for details.
5. "6" at the end of "input capacity symbol" indicates models with 6P motor. Other models come with 4P motor.

Selection Tables Gearmotors

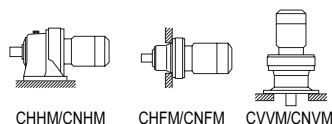

0.75 kW	Hz		50Hz		60Hz	
	P		4	6	4	6
	n ₁	r/min	1450	980	1750	1165

50Hz						60Hz					Nomenclature			Page of Dimension Sheet				
Output Speed n ₂ r/min	Output Torque Tout		Allowable Radial Load Pro		SF	Output Speed n ₂ r/min	Output Torque Tout		Allowable Radial Load Pro		SF	Input Capacity - Symbol	Frame Size - Ratio	Reduction Ratio	CNHM	CNFM	CNVM	
	N·m	kgf·m	N	kgf			N·m	kgf·m	N	kgf								CHHM
1.16	4060	414	41700	4250	*1	1.40	4060	414	41700	4250	*1	1 -	6180DA	-1247	B-110	B-126	B-145	
			41700	4250	0.90					41700	4250	1.09	1 -	6185DA	-1247	B-110	B-126	B-145
	5540	565	59000	6010	1.15		4590	468	59000	6010	1.39	1 -	6190DA	-1247	B-111	B-128	B-147	
			59000	6010	1.44					59000	6010	1.73	1 -	6195DA	-1247	B-111	B-128	B-147
0.980	4060	414	41700	4250	*1	1.18	4060	414	41700	4250	*1	1 -	6180DA	-1479	B-110	B-126	B-145	
	5000	510	41700	4250	*1		5000	510	41700	4250	*1	1 -	6185DA	-1479	B-110	B-126	B-145	
	6580	670	58800	5990	1.21		5450	555	59000	6010	1.46	1 -	6195DA	-1479	B-111	B-128	B-147	
0.784	5000	510	41700	4250	*1	0.946	5000	510	41700	4250	*1	1 -	6185DA	-1849	B-110	B-126	B-145	
	6380	650	59000	6010	*1		6380	650	59000	6010	*1	1 -	6190DA	-1849	B-111	B-128	B-147	
	8220	838	58900	6000	0.97		6810	694	59000	6010	1.17	1 -	6195DA	-1849	B-111	B-128	B-147	
0.702	5000	510	41600	4240	*1	0.847	5000	510	41600	4240	*1	1 -	6185DA	-2065	B-110	B-126	B-145	
	6380	650	58600	5970	*1		6380	650	58600	5970	*1	1 -	6190DA	-2065	B-111	B-128	B-147	
	9180	936	57800	5890	0.87		7610	775	58200	5940	1.05	1 -	6195DA	-2065	B-111	B-128	B-147	
0.572	6380	650	58600	5970	*1	0.690	6380	650	58600	5970	*1	1 -	6190DA	-2537	B-111	B-128	B-147	
	7960	811	58100	5930	*1		7960	811	58100	5930	*1	1 -	6195DA	-2537	B-111	B-128	B-147	
	9300	948	84100	8570	*1		9300	948	84100	8570	*1	1 -	6205DA	-2537	B-112	B-129	B-148	
	11300	1150	84100	8570	0.82		9350	953	84100	8570	1.00	1 -	6205DA	-2537	B-112	B-129	B-148	
0.476	6380	650	58900	6000	*1	0.575	6380	650	58900	6000	*1	1 -	6190DA	-3045	B-111	B-128	B-147	
	7960	811	58400	5950	*1		7960	811	58400	5950	*1	1 -	6195DA	-3045	B-111	B-128	B-147	
	8760	893	84100	8570	*1		8760	893	84100	8570	*1	1 -	6205DA	-3045	B-112	B-129	B-148	
0.417	6380	650	58600	5970	*1	0.503	6380	650	58600	5970	*1	1 -	6190DA	-3481	B-111	B-128	B-147	
	7960	811	58100	5930	*1		7960	811	58100	5930	*1	1 -	6195DA	-3481	B-111	B-128	B-147	
	9300	948	84100	8570	*1		9300	948	84100	8570	*1	1 -	6205DA	-3481	B-112	B-129	B-148	
0.327	6380	650	58900	6000	*1	0.394	6380	650	58900	6000	*1	1 -	6190DA	-4437	B-111	B-128	B-147	
	7960	811	58400	5950	*1		7960	811	58400	5950	*1	1 -	6195DA	-4437	B-111	B-128	B-147	
	8760	893	84100	8570	*1		8760	893	84100	8570	*1	1 -	6205DA	-4437	B-112	B-129	B-148	
0.282	6380	650	58900	6000	*1	0.341	6380	650	58900	6000	*1	1 -	6190DA	-5133	B-111	B-128	B-147	
	7960	811	58400	5950	*1		7960	811	58400	5950	*1	1 -	6195DA	-5133	B-111	B-128	B-147	
	9300	948	84100	8570	*1		9300	948	84100	8570	*1	1 -	6205DA	-5133	B-112	B-129	B-148	
0.235	6380	650	58900	6000	*1	0.283	6380	650	58900	6000	*1	1 -	6190DA	-6177	B-111	B-128	B-147	
	7960	811	58400	5950	*1		7960	811	58400	5950	*1	1 -	6195DA	-6177	B-111	B-128	B-147	
	8760	893	84100	8570	*1		8760	893	84100	8570	*1	1 -	6205DA	-6177	B-112	B-129	B-148	
0.192	6380	650	58900	6000	*1	0.231	6380	650	58900	6000	*1	1 -	6190DA	-7569	B-111	B-128	B-147	
	7960	811	58400	5950	*1		7960	811	58400	5950	*1	1 -	6195DA	-7569	B-111	B-128	B-147	
	8760	893	84100	8570	*1		8760	893	84100	8570	*1	1 -	6205DA	-7569	B-112	B-129	B-148	

SELECTION TABLES
GEARMOTORS
0.75 kW

- "*2" indicate models manufactured with reducer and motor separately mounted on a common baseplate (horizontal shaft direction) or on an adaptor (vertical shaft direction). Consult us for details, including dimensions.
- Allowable radial load (Pro) is the value at the midpoint of the slow speed shaft.
- "*3" indicate models with reduction ratios equal to nominal ratio. Refer to Table A-3 "6000SK Series (Actual Reduction Ratio)" on page A-4 for actual reduction ratio. Indicated reduction ratio is the same as actual reduction ratio for other models.
- Maintain torque load during operation within "Output torque" in the table for models with "*" in the SF column. They cannot be operated with 100% motor rating.

Selection Tables Gearmotors

1.1 kW		n ₁ : Motor Speed					
		Hz		50Hz		60Hz	
		P	4	6	4	6	
n ₁	r/min	1450	980	1750	1165		

50Hz					60Hz					Nomenclature			Page of Dimension Sheet				
Output Speed n ₂ r/min	Output Torque Tout N·m	kgf·m	Allowable Radial Load Pro N	SF	Output Speed n ₂ r/min	Output Torque Tout N·m	kgf·m	Allowable Radial Load Pro N	SF	Input Capacity Symbol	Frame Size	Reduction Ratio	CNHM	CNFM	CNVM		
			kgf					kgf					CHHM	CHFM	CVVM		
580	17.2	1.75	1200	1.50	700	14.3	1.45	1140	1.50	1H - 6080SK	- 2.5 *3	B-98	-	B-133			
			1200	1.87				1140	1.87	1H - 6085SK	- 2.5 *3	B-98	-	B-133			
			2230	2.18				2120	2.18	1H - 6090SK	- 2.5 *3	B-98	-	B-133			
			2230	2.46				2120	2.46	1H - 6095SK	- 2.5 *3	B-98	-	B-133			
			2230	2.90				2120	2.90	1H - 6100SK	- 2.5 *3	B-99	-	B-134			
			2230	3.41				2120	3.41	1H - 6105SK	- 2.5 *3	B-99	-	B-134			
483	20.6	2.10	1250	1.50	583	17.1	1.74	1200	1.50	1H - 6080SK	- 3 *3	B-98	-	B-133			
			1250	1.87				1200	1.87	1H - 6085SK	- 3 *3	B-98	-	B-133			
			2310	2.13				2210	2.13	1H - 6090SK	- 3 *3	B-98	-	B-133			
			2310	2.39				2210	2.39	1H - 6095SK	- 3 *3	B-98	-	B-133			
			2310	3.00				2210	3.00	1H - 6100SK	- 3 *3	B-99	-	B-134			
363	27.5	2.81	1330	1.50	438	22.8	2.33	1290	1.50	1H - 6080SK	- 4 *3	B-98	-	B-133			
			1330	1.87				1290	1.87	1H - 6085SK	- 4 *3	B-98	-	B-133			
			2560	2.13				2450	2.13	1H - 6090SK	- 4 *3	B-98	-	B-133			
			2560	2.39				2450	2.39	1H - 6095SK	- 4 *3	B-98	-	B-133			
			2560	2.93				2450	2.93	1H - 6100SK	- 4 *3	B-99	-	B-134			
			2560	3.45				2450	3.45	1H - 6105SK	- 4 *3	B-99	-	B-134			
290	34.4	3.51	1420	1.41	350	28.5	2.91	1370	1.41	1H - 6080SK	- 5 *3	B-98	-	B-133			
			1420	1.65				1370	1.65	1H - 6085SK	- 5 *3	B-98	-	B-133			
			2740	2.03				2600	2.03	1H - 6090SK	- 5 *3	B-98	-	B-133			
			2740	2.39				2600	2.39	1H - 6095SK	- 5 *3	B-98	-	B-133			
			2740	2.86				2600	2.86	1H - 6100SK	- 5 *3	B-99	-	B-134			
			2740	3.36				2600	3.36	1H - 6105SK	- 5 *3	B-99	-	B-134			
242	41.3	4.21	1450	1.18	292	34.2	3.49	1410	1.18	1H - 6080SK	- 6 *3	B-98	-	B-133			
			1450	1.47				1410	1.47	1H - 6085SK	- 6 *3	B-98	-	B-133			
			2800	1.74				2670	1.74	1H - 6090SK	- 6 *3	B-98	-	B-133			
			2800	2.06				2670	2.06	1H - 6095SK	- 6 *3	B-98	-	B-133			
			2800	2.43				2670	2.43	1H - 6100SK	- 6 *3	B-99	-	B-134			
			2800	2.85				2670	2.85	1H - 6105SK	- 6 *3	B-99	-	B-134			
			2820	1.05				2650	1.05	1H - 6090	- 6	B-100	B-116	B-135			
			2820	1.38				2650	1.38	1H - 6095	- 6	B-100	B-116	B-135			
			4140	2.14				3900	2.14	1H - 6100	- 6	B-101	B-117	B-136			
			4140	2.89				3900	2.89	1H - 6105	- 6	B-101	B-117	B-136			
			1490	1.00				219	45.6	4.65	1450	1.00	1H - 6080SK	- 8 *3	B-98	-	B-133
			1490	1.25							1450	1.25	1H - 6085SK	- 8 *3	B-98	-	B-133
3060	1.37	2930	1.37	1H - 6090SK	- 8 *3	B-98	-				B-133						
3060	1.61	2930	1.61	1H - 6095SK	- 8 *3	B-98	-				B-133						
3060	1.92	2930	1.92	1H - 6100SK	- 8 *3	B-99	-				B-134						
3060	2.26	2930	2.26	1H - 6105SK	- 8 *3	B-99	-				B-134						
4080	3.37	3870	3.37	1H - 6110SK	- 8 *3	B-99	-				B-134						
3130	1.05	2950	1.05	1H - 6090	- 8	B-100	B-116				B-135						
3130	1.38	2950	1.38	1H - 6095	- 8	B-100	B-116				B-135						
4620	2.14	4350	2.14	1H - 6100	- 8	B-101	B-117				B-136						
4620	2.89	4350	2.89	1H - 6105	- 8	B-101	B-117				B-136						
145	68.8	7.02	1540	1.00	175	57.0	5.81				1510	1.00	1H - 6085SK	- 10 *3	B-98	-	B-133
			3220	1.27				3070	1.27	1H - 6090SK	- 10 *3	B-98	-	B-133			
			3220	1.61				3070	1.61	1H - 6095SK	- 10 *3	B-98	-	B-133			
			3220	1.80				3070	1.80	1H - 6100SK	- 10 *3	B-99	-	B-134			
			3220	2.00				3070	2.00	1H - 6105SK	- 10 *3	B-99	-	B-134			
			4400	2.78				4180	2.78	1H - 6110SK	- 10 *3	B-99	-	B-134			
			4400	3.47				4180	3.47	1H - 6115SK	- 10 *3	B-99	-	B-134			
			3340	1.05				159	62.7	6.39	3340	1.05	1H - 6090	- 11	B-100	B-116	B-135
3340	1.38	3340	1.38	1H - 6095	- 11	B-100	B-116				B-135						
5250	2.14	4950	2.14	1H - 6100	- 11	B-101	B-117				B-136						
5250	2.89	4950	2.89	1H - 6105	- 11	B-101	B-117				B-136						

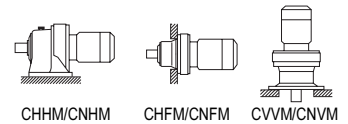

GEARMOTORS
Selection Tables
1.1 kW

- Combinations in **bold** are the recommended models for operations for 10 hours/day with uniform load (service factor is about 1.0 for motor rating at 50Hz).
- Motor slippage may affect n₁ and n₂. Refer to technical data for details.
- CNHM, CHHM, CNFM, CHFM, CNVM, and CVVM indicate types. Refer to page B-10 for details.
- Lubrication method is different for each model. Refer to "Lubrication" section in page F-4~F-5 for details.
- "6" at the end of "input capacity symbol" indicates models with 6P motor. Other models come with 4P motor.

Selection Tables Gearmotors

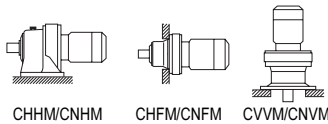

1.1 kW	Hz		50Hz		60Hz	
	P		4	6	4	6
	n ₁	r/min	1450	980	1750	1165

n₁: Motor Speed

50Hz					60Hz					Nomenclature			Page of Dimension Sheet							
Output Speed n ₂ r/min	Output Torque T _{out}		Allowable Radial Load Pro		SF	Output Speed n ₂ r/min	Output Torque T _{out}		Allowable Radial Load Pro		Input Capacity Symbol	Frame Size	Reduction Ratio	CNHM	CNFM	CNVM				
	N·m	kgf·m	N	kgf			N·m	kgf·m	N	kgf							CHHM	CHFM	CVVM	
112	89.5	9.12	3340	340	1.05	135	74.1	7.56	3340	340	1.38	1H -	6090	- 13	B-100	B-116	B-135			
			3340	340	1.38				3340	340	1.38				1H -	6095	- 13	B-100	B-116	B-135
			5400	550	2.14				5140	524	2.14				1H -	6100	- 13	B-101	B-117	B-136
			5400	550	2.89				5140	524	2.89				1H -	6105	- 13	B-101	B-117	B-136
96.7	103	10.5	3340	340	1.05	117	85.5	8.72	3340	340	1.38	1H -	6090	- 15	B-100	B-116	B-135			
			3340	340	1.38				3340	340	1.38				1H -	6095	- 15	B-100	B-116	B-135
			5400	550	2.14				5400	550	2.14				1H -	6100	- 15	B-101	B-117	B-136
			5400	550	2.89				5400	550	2.89				1H -	6105	- 15	B-101	B-117	B-136
85.3	117	11.9	3340	340	1.05	103	96.9	9.88	3340	340	1.38	1H -	6090	- 17	B-100	B-116	B-135			
			3340	340	1.38				3340	340	1.38				1H -	6095	- 17	B-100	B-116	B-135
			5400	550	1.81				5400	550	1.81				1H -	6100	- 17	B-101	B-117	B-136
			5400	550	2.24				5400	550	2.24				1H -	6105	- 17	B-101	B-117	B-136
69.0	145	14.7	3340	340	1.37	83.3	120	12.2	3340	340	1.38	1H -	6095	- 21	B-100	B-116	B-135			
			5400	550	1.73				5400	550	1.75				1H -	6100	- 21	B-101	B-117	B-136
			5400	550	2.07				5400	550	2.13				1H -	6105	- 21	B-101	B-117	B-136
			7080	722	2.47				6670	679	2.47				1H -	6110	- 21	B-101	B-117	B-136
58.0	172	17.5	5400	550	1.15	70.0	143	14.5	5400	550	1.52	1H -	6100	- 25	B-101	B-117	B-136			
			5400	550	1.52				5400	550	1.52				1H -	6105	- 25	B-101	B-117	B-136
			7180	732	1.74				6770	690	1.74				1H -	6110	- 25	B-101	B-117	B-136
			7180	732	2.02				6770	690	2.02				1H -	6115	- 25	B-101	B-117	B-136
50.0	200	20.3	5400	550	1.10	60.3	165	16.9	5400	550	1.45	1H -	6100	- 29	B-101	B-117	B-136			
			5400	550	1.45				5400	550	1.45				1H -	6105	- 29	B-101	B-117	B-136
			7350	750	1.73				6960	709	1.73				1H -	6110	- 29	B-101	B-117	B-136
			7350	750	2.02				6960	709	2.02				1H -	6115	- 29	B-101	B-117	B-136
41.4	241	24.6	5400	550	1.09	50.0	200	20.3	5400	550	1.36	1H -	6105	- 35	B-101	B-117	B-136			
			5400	550	1.09				5400	550	1.09				1H -	6110	- 35	B-101	B-117	B-136
			7400	754	1.36				7430	758	1.36				1H -	6110	- 35	B-101	B-117	B-136
			7400	754	1.65				7430	758	1.65				1H -	6115	- 35	B-101	B-117	B-136
33.7	296	30.2	5400	550	0.98	40.7	245	25.0	5400	550	1.09	1H -	6105	- 43	B-101	B-117	B-136			
			5400	550	0.98				5400	550	0.98				1H -	6110	- 43	B-101	B-117	B-136
			7610	776	1.18				7610	776	1.18				1H -	6115	- 43	B-101	B-117	B-136
			7610	776	1.38				7610	776	1.38				1H -	6115	- 43	B-101	B-117	B-136
28.4	351	35.8	9810	1000	1.74	34.3	291	29.6	9580	976	1.74	1H -	6120	- 43	B-101	B-117	B-136			
			9810	1000	1.79				9580	976	2.16				1H -	6125	- 43	B-101	B-117	B-136
			12500	1270	2.22				11300	1150	2.72				1H -	6130	- 43	B-102	B-118	B-137
			12500	1270	2.32				11800	1200	2.31				1H -	6135	- 51	B-102	B-118	B-137
24.6	406	41.4	7570	772	0.92	29.7	336	34.3	7610	776	0.92	1H -	6115	- 59	B-101	B-117	B-136			
			9810	1000	1.47				9810	1000	1.47				1H -	6125	- 59	B-101	B-117	B-136
			9810	1000	1.47				9810	1000	1.47				1H -	6125	- 59	B-101	B-117	B-136
			13100	1340	1.92				12300	1260	1.99				1H -	6130	- 59	B-102	B-118	B-137
20.4	489	49.8	13100	1340	2.22	24.6	405	41.3	12300	1260	2.29	1H -	6135	- 59	B-102	B-118	B-137			
			16000	1630	2.69				16000	1630	2.69				1H -	6140	- 59	B-102	B-118	B-137
			16000	1630	2.89				16000	1630	3.32				1H -	6145	- 59	B-102	B-118	B-137
			16000	1630	2.21				13900	1410	1.60				1H -	6130	- 71	B-102	B-118	B-137
20.4	489	49.8	13900	1410	1.85	24.6	405	41.3	13100	1330	1.66	1H -	6130	- 71	B-102	B-118	B-137			
			13900	1410	1.85				13100	1330	1.97				1H -	6135	- 71	B-102	B-118	B-137
			16000	1630	2.21				16000	1630	2.21				1H -	6140	- 71	B-102	B-118	B-137
			16000	1630	2.38				16000	1630	2.75				1H -	6145	- 71	B-102	B-118	B-137

GEARMOTORS
Selection Tables
1.1 kW

- "*2" indicate models manufactured with reducer and motor separately mounted on a common baseplate (horizontal shaft direction) or on an adaptor (vertical shaft direction). Consult us for details, including dimensions.
- Allowable radial load (Pro) is the value at the midpoint of the slow speed shaft.
- "*3" indicate models with reduction ratios equal to nominal ratio. Refer to Table A-3 "6000SK Series (Actual Reduction Ratio)" on page A-4 for actual reduction ratio. Indicated reduction ratio is the same as actual reduction ratio for other models.
- Maintain torque load during operation within "Output torque" in the table for models with "*" in the SF column. They cannot be operated with 100% motor rating.

Selection Tables Gearmotors

1.1 kW	Hz		50Hz		60Hz	
	P		4	6	4	6
	n ₁	r/min	1450	980	1750	1165

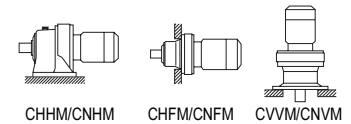

50Hz						60Hz						Nomenclature			Page of Dimension Sheet		
Output Speed n ₂ r/min	Output Torque Tout N·m kgf·m		Allowable Radial Load Pro N kgf		SF	Output Speed n ₂ r/min	Output Torque Tout N·m kgf·m		Allowable Radial Load Pro N kgf		SF	Input Capacity Symbol	Frame Size	Reduction Ratio	CNHM CHHM	CNFM CHFM	CNVM CVVM
16.7	599	61.0	9620	981	0.94	20.1	496	50.6	9810	1000	1.03	1H -	6125	- 87	B-101	B-117	B-136
			14700	1500	1.29				14100	1430	1.29	1H -	6130	- 87	B-102	B-118	B-137
			14700	1500	1.50				14100	1430	1.74	1H -	6135	- 87	B-102	B-118	B-137
			16000	1630	1.80				16000	1630	1.80	1H -	6140	- 87	B-102	B-118	B-137
			16000	1630	1.96				16000	1630	2.25	1H -	6145	- 87	B-102	B-118	B-137
			22100	2250	2.93				22100	2250	3.15	1H -	6160	- 87	B-103	B-119	B-138
13.9	678	69.1	525	53.5	*1	16.8	562	57.3	525	53.5	*1	1H -	6120DB	- 104	B-108	B-124	B-143
			9810	1000	0.93				9810	1000	1.12	1H -	6125DB	- 104	B-108	B-124	B-143
			14700	1500	1.15				14700	1500	1.39	1H -	6130DB	- 104	B-109	B-125	B-144
			14700	1500	1.39				14700	1500	1.45	1H -	6135DB	- 104	B-109	B-125	B-144
			16000	1630	1.45				16000	1630	1.45	1H -	6140DB	- 104	B-109	B-125	B-144
			16000	1630	1.81				16000	1630	2.18	1H -	6140DC	- 104	B-109	B-125	B-144
			16000	1630	2.02				16000	1630	2.44	1H -	6145DC	- 104	B-109	B-125	B-144
			22100	2250	2.59				22100	2250	3.05	1H -	6160DB	- 104	B-110	B-126	B-145
12.0	789	80.4	525	53.5	*1	14.5	654	66.6	525	53.5	*1	1H -	6120DB	- 121	B-108	B-124	B-143
			622	63.4	*1				622	63.4	*1	1H -	6125DB	- 121	B-108	B-124	B-143
			14700	1500	1.19				14700	1500	1.44	1H -	6135DB	- 121	B-109	B-125	B-144
			16000	1630	1.45				16000	1630	1.45	1H -	6140DB	- 121	B-109	B-125	B-144
			16000	1630	1.55				16000	1630	1.87	1H -	6140DC	- 121	B-109	B-125	B-144
			16000	1630	1.64				16000	1630	1.98	1H -	6145DC	- 121	B-109	B-125	B-144
			22100	2250	2.22				22100	2250	2.68	1H -	6160DB	- 121	B-110	B-126	B-145
			22100	2250	2.66				22100	2250	3.05	1H -	6165DB	- 121	B-110	B-126	B-145
10.1	932	95.0	630	64.2	*1	12.2	773	78.8	630	64.2	*1	1H -	6125DB	- 143	B-108	B-124	B-143
			14700	1500	1.01				14700	1500	1.22	1H -	6135DB	- 143	B-109	B-125	B-144
			16000	1630	1.31				16000	1630	1.45	1H -	6140DB	- 143	B-109	B-125	B-144
			16000	1630	1.31				16000	1630	1.59	1H -	6140DC	- 143	B-109	B-125	B-144
			16000	1630	1.45				16000	1630	1.45	1H -	6145DB	- 143	B-109	B-125	B-144
			16000	1630	1.47				16000	1630	1.77	1H -	6145DC	- 143	B-109	B-125	B-144
			22100	2250	1.88				22100	2250	2.27	1H -	6160DB	- 143	B-110	B-126	B-145
			22100	2250	2.25				22100	2250	2.72	1H -	6165DB	- 143	B-110	B-126	B-145
8.79	1080	110	630	64.2	*1	10.6	891	90.9	630	64.2	*1	1H -	6125DB	- 165	B-108	B-124	B-143
			780	79.5	*1				780	79.5	*1	1H -	6130DB	- 165	B-109	B-125	B-144
			14700	1500	0.87				14700	1500	1.05	1H -	6135DB	- 165	B-109	B-125	B-144
			16000	1630	1.14				16000	1630	1.37	1H -	6140DB	- 165	B-109	B-125	B-144
			16000	1630	1.26				16000	1630	1.45	1H -	6145DB	- 165	B-109	B-125	B-144
			16000	1630	1.26				16000	1630	1.52	1H -	6145DC	- 165	B-109	B-125	B-144
			22100	2250	1.45				22100	2250	1.45	1H -	6160DA	- 165	B-110	B-126	B-145
			22100	2250	1.63				22100	2250	1.97	1H -	6160DB	- 165	B-110	B-126	B-145
			22100	2250	1.95				22100	2250	2.36	1H -	6165DB	- 165	B-110	B-126	B-145
			29500	3010	2.35				29500	3010	2.84	1H -	6170DB	- 165	B-110	B-126	B-145
29500	3010	2.93	29500	3010	3.05	1H -	6175DB	- 165	B-110	B-126	B-145						
29500	3010	2.93	29500	3010	3.53	1H -	6175DC	- 165	B-111	B-127	B-146						

1. Combinations in **bold** are the recommended models for operations for 10 hours/day with uniform load (service factor is about 1.0 for motor rating at 50Hz).
2. Motor slippage may affect n₁ and n₂. Refer to technical data for details.
3. CNHM, CHHM, CNFM, CHFM, CNVM, and CVVM indicate types. Refer to page B-10 for details.
4. Lubrication method is different for each model. Refer to "Lubrication" section in page F-4~F-5 for details.
5. "6" at the end of "input capacity symbol" indicates models with 6P motor. Other models come with 4P motor.

Selection Tables Gearmotors

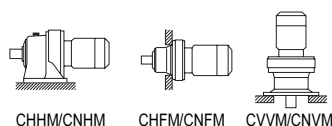

1.1 kW	Hz		50Hz		60Hz	
	P		4	6	4	6
	n ₁	r/min	1450	980	1750	1165

n₁: Motor Speed

50Hz					60Hz					Nomenclature			Page of Dimension Sheet				
Output Speed n ₂ r/min	Output Torque Tout		Allowable Radial Load Pro		SF	Output Speed n ₂ r/min	Output Torque Tout		Allowable Radial Load Pro		Input Capacity - Symbol	Frame Size - Ratio	Reduction Ratio	CNHM	CNFM	CNVM	
	N·m	kgf·m	N	kgf			N·m	kgf·m	N	kgf							CHHM
7.44	780	79.5	14700	1500	*1	8.97	780	79.5	14700	1500	*1	1H - 6130DB	- 195	B-109	B-125	B-144	
	940	95.8	14700	1500	*1		940	95.8	14700	1500	*1	1H - 6135DB	- 195	B-109	B-125	B-144	
			16000	1630	1.07					16000	1630	1.29	1H - 6145DB	- 195	B-109	B-125	B-144
			22100	2250	1.38					22100	2250	1.45	1H - 6160DA	- 195	B-110	B-126	B-145
			22100	2250	1.38					22100	2250	1.67	1H - 6160DB	- 195	B-110	B-126	B-145
	1270	130	22100	2250	1.45		1050	107	22100	2250	1.45	1H - 6165DA	- 195	B-110	B-126	B-145	
			22100	2250	1.65				22100	2250	1.99	1H - 6165DB	- 195	B-110	B-126	B-145	
			29500	3010	1.99				29500	3010	2.40	1H - 6170DB	- 195	B-110	B-126	B-145	
		29500	3010	2.48			29500	3010	2.99	1H - 6175DB	- 195	B-110	B-126	B-145			
6.28	940	95.8	14700	1500	*1	7.58	940	95.8	14700	1500	*1	1H - 6135DB	- 231	B-109	B-125	B-144	
	1230	125	16000	1630	*1		1230	125	16000	1630	*1	1H - 6140DB	- 231	B-109	B-125	B-144	
			15500	1580	0.89					16000	1630	1.07	1H - 6145DB	- 231	B-109	B-125	B-144
			22100	2250	1.17					22100	2250	1.41	1H - 6160DA	- 231	B-110	B-126	B-145
			22100	2250	1.39					22100	2250	1.45	1H - 6165DA	- 231	B-110	B-126	B-145
			22100	2250	1.39				22100	2250	1.68	1H - 6165DB	- 231	B-110	B-126	B-145	
	1510	154	29500	3010	1.45		1250	127	29500	3010	1.45	1H - 6170DA	- 231	B-110	B-126	B-145	
			29500	3010	1.68				29500	3010	2.03	1H - 6170DB	- 231	B-110	B-126	B-145	
		29500	3010	2.09			29500	3010	2.52	1H - 6175DB	- 231	B-110	B-126	B-145			
		41700	4250	2.69			41700	4250	3.05	1H - 6180DA	- 231	B-110	B-126	B-145			
		41700	4250	2.69			41700	4250	3.25	1H - 6180DB	- 231	B-111	B-127	B-146			
5.31	1230	125	16000	1630	*1	6.41	1230	125	16000	1630	*1	1H - 6140DB	- 273	B-109	B-125	B-144	
	1340	136	16000	1630	*1		1340	136	16000	1630	*1	1H - 6145DB	- 273	B-109	B-125	B-144	
			22100	2250	1.18					22100	2250	1.42	1H - 6165DA	- 273	B-110	B-126	B-145
			29500	3010	1.42					29500	3010	1.45	1H - 6170DA	- 273	B-110	B-126	B-145
			29500	3010	1.42					29500	3010	1.72	1H - 6170DB	- 273	B-110	B-126	B-145
			29500	3010	1.45				29500	3010	1.45	1H - 6175DA	- 273	B-110	B-126	B-145	
	1780	181	29500	3010	1.77		1470	150	29500	3010	2.14	1H - 6175DB	- 273	B-110	B-126	B-145	
			41700	4250	2.28				41700	4250	2.75	1H - 6180DA	- 273	B-110	B-126	B-145	
		41700	4250	2.81			41700	4250	3.05	1H - 6185DA	- 273	B-110	B-126	B-145			
		41700	4250	2.81			41700	4250	3.39	1H - 6185DB	- 273	B-111	B-127	B-146			
4.55	1230	125	16000	1630	*1	5.49	1230	125	16000	1630	*1	1H - 6140DB	- 319	B-109	B-125	B-144	
	1370	140	15800	1610	*1		1370	140	15800	1610	*1	1H - 6145DB	- 319	B-109	B-125	B-144	
			22100	2250	1.01					22100	2250	1.22	1H - 6165DA	- 319	B-110	B-126	B-145
			29500	3010	1.22					29500	3010	1.45	1H - 6170DA	- 319	B-110	B-126	B-145
			29500	3010	1.22					29500	3010	1.47	1H - 6170DB	- 319	B-110	B-126	B-145
			29500	3010	1.45				29500	3010	1.45	1H - 6175DA	- 319	B-110	B-126	B-145	
	2080	212	29500	3010	1.51		1720	176	29500	3010	1.83	1H - 6175DB	- 319	B-110	B-126	B-145	
			41700	4250	1.95				41700	4250	2.35	1H - 6180DA	- 319	B-110	B-126	B-145	
		41700	4250	2.40			41700	4250	2.90	1H - 6185DA	- 319	B-110	B-126	B-145			
3.85	1760	179	22100	2250	*1	4.64	1760	179	22100	2250	*1	1H - 6160DA	- 377	B-110	B-126	B-145	
			22100	2250	0.85					22100	2250	1.03	1H - 6165DA	- 377	B-110	B-126	B-145
			29500	3010	1.03					29500	3010	1.24	1H - 6170DA	- 377	B-110	B-126	B-145
			29500	3010	1.28					29500	3010	1.45	1H - 6175DA	- 377	B-110	B-126	B-145
			29500	3010	1.28				29500	3010	1.55	1H - 6175DB	- 377	B-110	B-126	B-145	
	2460	251	41700	4250	1.65		2040	208	41700	4250	1.99	1H - 6180DA	- 377	B-110	B-126	B-145	
			41700	4250	2.03				41700	4250	2.45	1H - 6185DA	- 377	B-110	B-126	B-145	
			59000	6010	2.60				59000	6010	3.13	1H - 6190DA	- 377	B-111	B-128	B-147	

GEARMOTORS

Selection Tables
1.1 kW

- "*2" indicate models manufactured with reducer and motor separately mounted on a common baseplate (horizontal shaft direction) or on an adaptor (vertical shaft direction). Consult us for details, including dimensions.
- Allowable radial load (Pro) is the value at the midpoint of the slow speed shaft.
- "*3" indicate models with reduction ratios equal to nominal ratio. Refer to Table A-3 "6000SK Series (Actual Reduction Ratio)" on page A-4 for actual reduction ratio. Indicated reduction ratio is the same as actual reduction ratio for other models.
- Maintain torque load during operation within "Output torque" in the table for models with "*" in the SF column. They cannot be operated with 100% motor rating.

Selection Tables Gearmotors

1.1 kW	Hz		50Hz		60Hz	
	P		4	6	4	6
	n ₁	r/min	1450	980	1750	1165

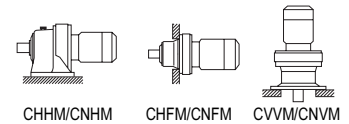

50Hz						60Hz					Nomenclature			Page of Dimension Sheet			
Output Speed n ₂ r/min	Output Torque T _{out}		Allowable Radial Load Pro		SF	Output Speed n ₂ r/min	Output Torque T _{out}		Allowable Radial Load Pro		SF	Input Capacity Symbol	Frame Size	Reduction Ratio	CNHM	CNFM	CNVM
	N·m	kgf·m	N	kgf			N·m	kgf·m	N	kgf							
3.07	2100	214	22100	2250	*1	3.70	2100	214	22100	2250	*1	1H - 6165DA	- 473	B-110	B-126	B-145	
	2530	258	29500	3010	*1		2530	258	29500	3010	*1	1H - 6170DA	- 473	B-110	B-126	B-145	
			29500	3010	1.02				29500	3010	1.23	1H - 6175DA	- 473	B-110	B-126	B-145	
			41700	4250	1.32				41700	4250	1.59	1H - 6180DA	- 473	B-110	B-126	B-145	
	3080	314	41700	4250	1.62		2560	260	41700	4250	1.96	1H - 6185DA	- 473	B-110	B-126	B-145	
			59000	6010	2.07				59000	6010	2.50	1H - 6190DA	- 473	B-111	B-128	B-147	
		59000	6010	2.58			59000	6010	3.11	1H - 6195DA	- 473	B-111	B-128	B-147			
2.59	2100	214	22100	2250	*1	3.13	2100	214	22100	2250	*1	1H - 6165DA	- 559	B-110	B-126	B-145	
	2530	258	29500	3010	*1		2530	258	29500	3010	*1	1H - 6170DA	- 559	B-110	B-126	B-145	
			29500	3010	0.86				29500	3010	1.04	1H - 6175DA	- 559	B-110	B-126	B-145	
			41700	4250	1.11				41700	4250	1.34	1H - 6180DA	- 559	B-110	B-126	B-145	
	3640	372	41700	4250	1.37		3020	308	41700	4250	1.66	1H - 6185DA	- 559	B-110	B-126	B-145	
			59000	6010	1.75				59000	6010	2.11	1H - 6190DA	- 559	B-111	B-128	B-147	
		59000	6010	2.18			59000	6010	2.64	1H - 6195DA	- 559	B-111	B-128	B-147			
2.23	2530	258	29500	3010	*1	2.70	2530	258	29500	3010	*1	1H - 6170DA	- 649	B-110	B-126	B-145	
	3150	321	29500	3010	*1		3150	321	29500	3010	*1	1H - 6175DA	- 649	B-110	B-126	B-145	
			41700	4250	1.18				41700	4250	1.43	1H - 6185DA	- 649	B-110	B-126	B-145	
	4230	431	59000	6010	1.51		3510	357	59000	6010	1.82	1H - 6190DA	- 649	B-111	B-128	B-147	
			59000	6010	1.88				59000	6010	2.27	1H - 6195DA	- 649	B-111	B-128	B-147	
			59000	6010	1.88				59000	6010	2.27	1H - 6195DA	- 649	B-111	B-128	B-147	
1.98	3150	321	29500	3010	*1	2.39	3150	321	29500	3010	*1	1H - 6175DA	- 731	B-110	B-126	B-145	
			41700	4250	1.05				41700	4250	1.27	1H - 6185DA	- 731	B-110	B-126	B-145	
	4770	486	59000	6010	1.34		3950	403	59000	6010	1.62	1H - 6190DA	- 731	B-111	B-128	B-147	
			59000	6010	1.67				59000	6010	2.02	1H - 6195DA	- 731	B-111	B-128	B-147	
1.72	3150	321	29500	3010	*1	2.08	3150	321	29500	3010	*1	1H - 6175DA	- 841	B-110	B-126	B-145	
	4050	413	41700	4250	*1		4050	413	41700	4250	*1	1H - 6180DA	- 841	B-110	B-126	B-145	
			41700	4250	0.91				41700	4250	1.10	1H - 6185DA	- 841	B-110	B-126	B-145	
	5480	559	59000	6010	1.16		4540	463	59000	6010	1.40	1H - 6190DA	- 841	B-111	B-128	B-147	
		59000	6010	1.45			59000	6010	1.75	1H - 6195DA	- 841	B-111	B-128	B-147			
1.45	4050	413	41700	4250	*1	1.74	4050	413	41700	4250	*1	1H - 6180DA	- 1003	B-110	B-126	B-145	
	5000	510	41600	4240	*1		5000	510	41600	4240	*1	1H - 6185DA	- 1003	B-110	B-126	B-145	
	6540	667	58500	5970	1.22		5420	552	58800	6000	1.47	1H - 6195DA	- 1003	B-111	B-128	B-147	
1.16	5000	510	41700	4250	*1	1.40	5000	510	41700	4250	*1	1H - 6185DA	- 1247	B-110	B-126	B-145	
	6380	650	59000	6010	*1		6380	650	59000	6010	*1	1H - 6190DA	- 1247	B-111	B-128	B-147	
	8130	829	58900	6010	0.98		6740	687	59000	6010	1.18	1H - 6195DA	- 1247	B-111	B-128	B-147	
0.980	6380	650	58900	6000	*1	1.18	6380	650	58900	6000	*1	1H - 6190DA	- 1479	B-111	B-128	B-147	
	7960	811	58400	5950	*1		7960	811	58400	5950	*1	1H - 6195DA	- 1479	B-111	B-128	B-147	
	9640	983	57800	5900	0.83		7990	815	58400	5950	1.00	1H - 6195DA	- 1479	B-111	B-128	B-147	
0.784	7960	811	59000	6010	*1	0.946	7960	811	59000	6010	*1	1H - 6195DA	- 1849	B-111	B-128	B-147	
0.702	7960	811	58100	5930	*1	0.847	7960	811	58100	5930	*1	1H - 6195DA	- 2065	B-111	B-128	B-147	

1. Combinations in **bold** are the recommended models for operations for 10 hours/day with uniform load (service factor is about 1.0 for motor rating at 50Hz).
2. Motor slippage may affect n₁ and n₂. Refer to technical data for details.
3. CNHM, CHHM, CNFM, CHFM, CNVM, and CVVM indicate types. Refer to page B-10 for details.
4. Lubrication method is different for each model. Refer to "Lubrication" section in page F-4~F-5 for details.
5. "6" at the end of "input capacity symbol" indicates models with 6P motor. Other models come with 4P motor.

Selection Tables Gearmotors

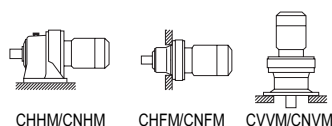

1.5 kW	Hz		50Hz		60Hz	
	P		4	6	4	6
	n ₁	r/min	1450	980	1750	1165

n₁: Motor Speed

50Hz					60Hz					Nomenclature			Page of Dimension Sheet			
Output Speed n ₂ r/min	Output Torque Tout		Allowable Radial Load Pro		SF	Output Speed n ₂ r/min	Output Torque Tout		Allowable Radial Load Pro		Input Capacity Symbol	Frame Size	Reduction Ratio	CNHM	CNFM	CNVM
	N·m	kgf·m	N	kgf			N·m	kgf·m	N	kgf						
580	23.5	2.39	1130	115	1.10	700	19.4	1.98	1090	111	1.10	2 - 6080SK	- 2.5 *3	B-98	-	B-133
			1130	115	1.37				1090	111	1.37	2 - 6085SK	- 2.5 *3	B-98	-	B-133
			2140	218	1.60				2050	209	1.60	2 - 6090SK	- 2.5 *3	B-98	-	B-133
			2140	218	1.81				2050	209	1.81	2 - 6095SK	- 2.5 *3	B-98	-	B-134
			2140	218	2.12				2050	209	2.12	2 - 6100SK	- 2.5 *3	B-99	-	B-134
			2140	218	2.50				2050	209	2.50	2 - 6105SK	- 2.5 *3	B-99	-	B-134
483	28.2	2.87	1170	119	1.10	583	23.3	2.38	1130	115	1.10	2 - 6080SK	- 3 *3	B-98	-	B-133
			1170	119	1.37				1130	115	1.37	2 - 6085SK	- 3 *3	B-98	-	B-133
			2230	227	1.56				2120	216	1.56	2 - 6090SK	- 3 *3	B-98	-	B-133
			2230	227	1.75				2120	216	1.75	2 - 6095SK	- 3 *3	B-98	-	B-133
			2230	227	2.20				2120	216	2.20	2 - 6100SK	- 3 *3	B-99	-	B-134
			2230	227	2.59				2120	216	2.59	2 - 6105SK	- 3 *3	B-99	-	B-134
363	37.5	3.83	1250	127	1.10	438	31.1	3.17	1210	123	1.10	2 - 6080SK	- 4 *3	B-98	-	B-133
			1250	127	1.37				1210	123	1.37	2 - 6085SK	- 4 *3	B-98	-	B-133
			2470	252	1.56				2370	242	1.56	2 - 6090SK	- 4 *3	B-98	-	B-133
			2470	252	1.75				2370	242	1.75	2 - 6095SK	- 4 *3	B-98	-	B-133
			2470	252	2.15				2370	242	2.15	2 - 6100SK	- 4 *3	B-99	-	B-134
			3280	334	3.57				2370	242	2.53	2 - 6105SK	- 4 *3	B-99	-	B-134
290	46.9	4.78	1290	132	1.21	350	38.9	3.96	1270	129	1.21	2 - 6080SK	- 5 *3	B-98	-	B-133
			2590	264	1.49				2490	254	1.49	2 - 6090SK	- 5 *3	B-98	-	B-133
			2590	264	1.75				2490	254	1.75	2 - 6095SK	- 5 *3	B-98	-	B-133
			2590	264	2.10				2490	254	2.10	2 - 6100SK	- 5 *3	B-99	-	B-134
			2590	264	2.47				2490	254	2.47	2 - 6105SK	- 5 *3	B-99	-	B-134
			3460	353	3.07				3290	335	3.07	2 - 6110SK	- 5 *3	B-99	-	B-134
242	56.3	5.74	1290	132	1.08	292	46.7	4.76	1290	131	1.08	2 - 6085SK	- 6 *3	B-98	-	B-133
			2660	271	1.27				2530	258	1.27	2 - 6090SK	- 6 *3	B-98	-	B-133
			2660	271	1.51				2530	258	1.51	2 - 6095SK	- 6 *3	B-98	-	B-133
			2660	271	1.78				2530	258	1.78	2 - 6100SK	- 6 *3	B-99	-	B-134
			2660	271	2.09				2530	258	2.09	2 - 6105SK	- 6 *3	B-99	-	B-134
			3700	377	2.82				3510	358	2.82	2 - 6110SK	- 6 *3	B-99	-	B-134
			2790	284	1.01				2630	268	1.01	2 - 6095	- 6	B-100	B-116	B-135
			4130	421	1.57				3880	396	1.57	2 - 6100	- 6	B-101	B-117	B-136
			4130	421	2.12				3880	396	2.12	2 - 6105	- 6	B-101	B-117	B-136
			4670	476	2.37				4390	447	2.37	2 - 6110	- 6	B-101	B-117	B-136
4670	476	2.61	4390	447	2.61	2 - 6115	- 6	B-101	B-117	B-136						
181	75.1	7.65	1290	132	0.91	219	62.2	6.34	1290	132	0.91	2 - 6085SK	- 8 *3	B-98	-	B-133
			2870	293	1.00				2780	283	1.00	2 - 6090SK	- 8 *3	B-98	-	B-133
			2870	293	1.18				2780	283	1.18	2 - 6095SK	- 8 *3	B-98	-	B-133
			2870	293	1.41				2780	283	1.41	2 - 6100SK	- 8 *3	B-99	-	B-134
			2870	293	1.66				2780	283	1.66	2 - 6105SK	- 8 *3	B-99	-	B-134
			3950	403	2.47				3770	384	2.47	2 - 6110SK	- 8 *3	B-99	-	B-134
			3950	403	3.09				3770	384	3.09	2 - 6115SK	- 8 *3	B-99	-	B-134
			3090	315	1.01				2920	297	1.01	2 - 6095	- 8	B-100	B-116	B-135
			4600	469	1.57				4330	441	1.57	2 - 6100	- 8	B-101	B-117	B-136
			4600	469	2.12				4330	441	2.12	2 - 6105	- 8	B-101	B-117	B-136
			5210	531	2.37				4900	499	2.37	2 - 6110	- 8	B-101	B-117	B-136
			5210	531	2.61				4900	499	2.61	2 - 6115	- 8	B-101	B-117	B-136
145	93.9	9.57	2990	305	1.18	175	77.8	7.93	2900	296	1.18	2 - 6095SK	- 10 *3	B-98	-	B-133
			2990	305	1.32				2900	296	1.32	2 - 6100SK	- 10 *3	B-99	-	B-134
			2990	305	1.47				2900	296	1.47	2 - 6105SK	- 10 *3	B-99	-	B-134
			4250	433	2.04				4050	413	2.04	2 - 6110SK	- 10 *3	B-99	-	B-134
			4250	433	2.55				4050	413	2.55	2 - 6115SK	- 10 *3	B-99	-	B-134

GEARMOTORS
Selection Tables
1.5 kW

- "*2" indicate models manufactured with reducer and motor separately mounted on a common baseplate (horizontal shaft direction) or on an adaptor (vertical shaft direction). Consult us for details, including dimensions.
- Allowable radial load (Pro) is the value at the midpoint of the slow speed shaft.
- "*3" indicate models with reduction ratios equal to nominal ratio. Refer to Table A-3 "6000SK Series (Actual Reduction Ratio)" on page A-4 for actual reduction ratio. Indicated reduction ratio is the same as actual reduction ratio for other models.
- Maintain torque load during operation within "Output torque" in the table for models with "*" in the SF column. They cannot be operated with 100% motor rating.

Selection Tables Gearmotors

1.5 kW	Hz		50Hz		60Hz	
	P		4	6	4	6
	n ₁	r/min	1450	980	1750	1165

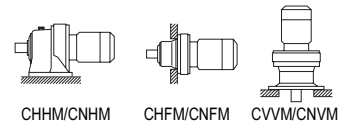

50Hz					60Hz					Nomenclature			Page of Dimension Sheet			
Output Speed n ₂ r/min	Output Torque Tout N·m	kgf·m	Allowable Radial Load Pro N	SF	Output Speed n ₂ r/min	Output Torque Tout N·m	kgf·m	Allowable Radial Load Pro N	SF	Input Capacity Symbol	Frame Size	Reduction Ratio	CNHM CHHM	CNFM CHFM	CNVM CVVM	
132	103	10.5	3340	340	1.01	159	85.5	8.72	3300	336	1.01	2 - 6095	- 11	B-100	B-116	B-135
			5220	532	1.57				4920	501	1.57	2 - 6100	- 11	B-101	B-117	B-136
			5220	532	2.12				4920	501	2.12	2 - 6105	- 11	B-101	B-117	B-136
			5950	606	2.37				5600	571	2.37	2 - 6110	- 11	B-101	B-117	B-136
			5950	606	2.61				5600	571	2.61	2 - 6115	- 11	B-101	B-117	B-136
112	122	12.4	3340	340	1.01	135	101	10.3	3300	336	1.01	2 - 6095	- 13	B-100	B-116	B-135
			5400	550	1.57				5110	521	1.57	2 - 6100	- 13	B-101	B-117	B-136
			5400	550	2.12				5110	521	2.12	2 - 6105	- 13	B-101	B-117	B-136
			6150	627	2.37				5790	591	2.37	2 - 6110	- 13	B-101	B-117	B-136
			6150	627	2.60				5790	591	2.60	2 - 6115	- 13	B-101	B-117	B-136
96.7	141	14.4	3340	340	1.01	117	117	11.9	3280	335	1.01	2 - 6095	- 15	B-100	B-116	B-135
			5400	550	1.57				5400	550	1.57	2 - 6100	- 15	B-101	B-117	B-136
			5400	550	2.12				5400	550	2.12	2 - 6105	- 15	B-101	B-117	B-136
			6560	669	2.37				6180	630	2.37	2 - 6110	- 15	B-101	B-117	B-136
			6560	669	2.60				6180	630	2.60	2 - 6115	- 15	B-101	B-117	B-136
85.3	160	16.3	3340	340	1.01	103	132	13.5	3290	336	1.01	2 - 6095	- 17	B-100	B-116	B-135
			5400	550	1.33				5400	550	1.33	2 - 6100	- 17	B-101	B-117	B-136
			5400	550	1.64				5400	550	1.64	2 - 6105	- 17	B-101	B-117	B-136
			6620	675	2.12				6240	636	2.12	2 - 6110	- 17	B-101	B-117	B-136
			6620	675	2.60				6240	636	2.60	2 - 6115	- 17	B-101	B-117	B-136
69.0	197	20.1	3340	340	1.01	83.3	163	16.6	3260	332	1.01	2 - 6095	- 21	B-100	B-116	B-135
			5400	550	1.27				5400	550	1.29	2 - 6100	- 21	B-101	B-117	B-136
			5400	550	1.52				5400	550	1.56	2 - 6105	- 21	B-101	B-117	B-136
			7020	716	1.81				6620	675	1.81	2 - 6110	- 21	B-101	B-117	B-136
			7020	716	2.07				6620	675	2.07	2 - 6115	- 21	B-101	B-117	B-136
8260	842	2.64	7780	793	2.64	2 - 6120	- 21	B-101	B-117	B-136						
58.0	235	23.9	5400	550	1.11	70.0	194	19.8	5400	550	1.11	2 - 6105	- 25	B-101	B-117	B-136
			7120	726	1.27				6720	685	1.27	2 - 6110	- 25	B-101	B-117	B-136
			7120	726	1.48				6720	685	1.48	2 - 6115	- 25	B-101	B-117	B-136
			8650	882	2.06				8150	831	2.06	2 - 6120	- 25	B-101	B-117	B-136
			8650	882	2.64				8150	831	2.64	2 - 6125	- 25	B-101	B-117	B-136
50.0	272	27.7	5400	550	1.06	60.3	226	23.0	5400	550	1.06	2 - 6105	- 29	B-101	B-117	B-136
			7290	743	1.27				6900	703	1.27	2 - 6110	- 29	B-101	B-117	B-136
			7290	743	1.48				6900	703	1.48	2 - 6115	- 29	B-101	B-117	B-136
			8990	916	1.91				8470	863	1.99	2 - 6120	- 29	B-101	B-117	B-136
			8990	916	2.31				8470	863	2.51	2 - 6125	- 29	B-101	B-117	B-136
10500	1070	2.87	9920	1010	2.99	2 - 6130	- 29	B-102	B-118	B-137						
41.4	328	33.5	4820	491	0.80	50.0	272	27.7	5330	544	0.80	2 - 6105	- 35	B-101	B-117	B-136
			7310	745	1.00				7360	751	1.00	2 - 6110	- 35	B-101	B-117	B-136
			7310	745	1.21				7360	751	1.21	2 - 6115	- 35	B-101	B-117	B-136
			9490	967	1.58				8940	912	1.66	2 - 6120	- 35	B-101	B-117	B-136
			9490	967	1.92				8940	912	2.12	2 - 6125	- 35	B-101	B-117	B-136
11100	1130	2.37	10400	1060	2.47	2 - 6130	- 35	B-102	B-118	B-137						
11100	1130	2.74	10400	1060	2.83	2 - 6135	- 35	B-102	B-118	B-137						
33.7	404	41.1	7540	769	1.01	40.7	334	34.1	7610	776	1.01	2 - 6115	- 43	B-101	B-117	B-136
			9810	1000	1.27				9510	969	1.27	2 - 6120	- 43	B-101	B-117	B-136
			9810	1000	1.56				9510	969	1.59	2 - 6125	- 43	B-101	B-117	B-136
			11900	1210	1.93				11200	1140	1.99	2 - 6130	- 43	B-102	B-118	B-137
			11900	1210	2.23				11200	1140	2.51	2 - 6135	- 43	B-102	B-118	B-137
16000	1630	2.63	15900	1620	2.63	2 - 6140	- 43	B-102	B-118	B-137						
28.4	479	48.8	9810	1000	1.09	34.3	397	40.4	9810	1000	1.15	2 - 6120	- 51	B-101	B-117	B-136
			9810	1000	1.31				9810	1000	1.52	2 - 6125	- 51	B-101	B-117	B-136
			12400	1260	1.63				11700	1190	1.69	2 - 6130	- 51	B-102	B-118	B-137
			12400	1260	1.70				11700	1190	1.95	2 - 6135	- 51	B-102	B-118	B-137
			16000	1630	2.29				16000	1630	2.29	2 - 6140	- 51	B-102	B-118	B-137
16000	1630	2.47	16000	1630	2.81	2 - 6145	- 51	B-102	B-118	B-137						

1. Combinations in **bold** are the recommended models for operations for 10 hours/day with uniform load (service factor is about 1.0 for motor rating at 50Hz).
2. Motor slippage may affect n₁ and n₂. Refer to technical data for details.
3. CNHM, CHHM, CNFM, CHFM, CNVM, and CVVM indicate types. Refer to page B-10 for details.
4. Lubrication method is different for each model. Refer to "Lubrication" section in page F-4~F-5 for details.
5. "6" at the end of "input capacity symbol" indicates models with 6P motor. Other models come with 4P motor.

Selection Tables Gearmotors

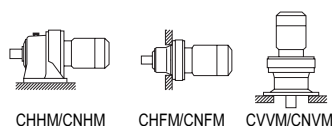

1.5 kW	Hz		50Hz		60Hz	
	P		4	6	4	6
	n ₁	r/min	1450	980	1750	1165

50Hz						60Hz						Nomenclature			Page of Dimension Sheet								
Output Speed n ₂ r/min	Output Torque Tout		Allowable Radial Load Pro		SF	Output Speed n ₂ r/min	Output Torque Tout		Allowable Radial Load Pro		SF	Input Capacity Symbol	Frame Size	Reduction Ratio	CNHM	CNFM	CNVM						
	N·m	kgf·m	N	kgf			N·m	kgf·m	N	kgf													
24.6	554	56.4	9810	1000	1.08	29.7	459	46.8	9810	1000	1.08	2 -	6125	- 59	B-101	B-117	B-136						
			13000	1320	1.41				12200	1250	1.46							2 -	6130	- 59	B-102	B-118	B-137
			13000	1320	1.63				12200	1250	1.68							2 -	6135	- 59	B-102	B-118	B-137
			16000	1630	1.97				16000	1630	1.97							2 -	6140	- 59	B-102	B-118	B-137
			16000	1630	2.12				16000	1630	2.43							2 -	6145	- 59	B-102	B-118	B-137
			22100	2250	2.95				22100	2250	2.95							2 -	6160	- 59	B-103	B-119	B-138
20.4	666	67.9	13700	1400	1.17	24.6	552	56.3	12900	1320	1.22	2 -	6130	- 71	B-102	B-118	B-137						
			13700	1400	1.35				12900	1320	1.45							2 -	6135	- 71	B-102	B-118	B-137
			16000	1630	1.62				16000	1630	1.62							2 -	6140	- 71	B-102	B-118	B-137
			16000	1630	1.75				16000	1630	2.02							2 -	6145	- 71	B-102	B-118	B-137
			22100	2250	2.31				22100	2250	2.31							2 -	6160	- 71	B-103	B-119	B-138
16.7	817	83.2	14700	1500	1.10	20.1	677	69.0	13900	1420	1.27	2 -	6135	- 87	B-102	B-118	B-137						
			16000	1630	1.32				16000	1630	1.32							2 -	6140	- 87	B-102	B-118	B-137
			16000	1630	1.44				16000	1630	1.65							2 -	6145	- 87	B-102	B-118	B-137
			22100	2250	2.15				22100	2250	2.31							2 -	6160	- 87	B-103	B-119	B-138
			22100	2250	2.51				22100	2250	2.60							2 -	6165	- 87	B-103	B-119	B-138
13.9	925	94.3	630	64.2	9810	1000	*1	630	64.2	9810	1000	*1	2 -	6125DB	- 104	B-108	B-124	B-143					
			14700	1500	1.02	14700	1500	1.07	2 -	6135DB	- 104	B-109	B-125	B-144									
			14700	1500	1.02	14700	1500	1.23	2 -	6135DC	- 104	B-109	B-125	B-144									
			16000	1630	1.07	16000	1630	1.07	2 -	6140DB	- 104	B-109	B-125	B-144									
			16000	1630	1.32	16000	1630	1.60	2 -	6140DC	- 104	B-109	B-125	B-144									
			16000	1630	1.48	16000	1630	1.79	2 -	6145DC	- 104	B-109	B-125	B-144									
			22100	2250	1.90	22100	2250	2.24	2 -	6160DB	- 104	B-110	B-126	B-145									
			22100	2250	1.90	22100	2250	2.29	2 -	6160DC	- 104	B-111	B-127	B-146									
			22100	2250	2.24	22100	2250	2.24	2 -	6165DB	- 104	B-110	B-126	B-145									
			22100	2250	2.27	22100	2250	2.74	2 -	6165DC	- 104	B-111	B-127	B-146									
29500	3010	2.73	29500	3010	3.30	2 -	6170DC	- 104	B-111	B-127	B-146												
12.0	1080	110	780	79.5	14700	1500	*1	780	79.5	14700	1500	*1	2 -	6130DB	- 121	B-109	B-125	B-144					
			14700	1500	0.87	14700	1500	1.05	2 -	6135DB	- 121	B-109	B-125	B-144									
			16000	1630	1.07	16000	1630	1.07	2 -	6140DB	- 121	B-109	B-125	B-144									
			16000	1630	1.14	16000	1630	1.37	2 -	6140DC	- 121	B-109	B-125	B-144									
			16000	1630	1.20	16000	1630	1.45	2 -	6145DC	- 121	B-109	B-125	B-144									
			22100	2250	1.63	22100	2250	1.97	2 -	6160DB	- 121	B-110	B-126	B-145									
			22100	2250	1.95	22100	2250	2.24	2 -	6165DB	- 121	B-110	B-126	B-145									
			22100	2250	1.95	22100	2250	2.36	2 -	6165DC	- 121	B-111	B-127	B-146									
			29500	3010	2.24	29500	3010	2.24	2 -	6170DB	- 121	B-110	B-126	B-145									
			29500	3010	2.35	29500	3010	2.84	2 -	6170DC	- 121	B-111	B-127	B-146									
29500	3010	2.93	29500	3010	3.53	2 -	6175DC	- 121	B-111	B-127	B-146												
10.1	1270	130	780	79.5	14700	1500	*1	780	79.5	14700	1500	*1	2 -	6130DB	- 143	B-109	B-125	B-144					
			940	95.8	14700	1500	*1	940	95.8	14700	1500	*1	2 -	6135DB	- 143	B-109	B-125	B-144					
			16000	1630	1.07	16000	1630	1.07	2 -	6145DB	- 143	B-109	B-125	B-144									
			16000	1630	1.08	16000	1630	1.30	2 -	6145DC	- 143	B-109	B-125	B-144									
			22100	2250	1.38	22100	2250	1.67	2 -	6160DB	- 143	B-110	B-126	B-145									
			22100	2250	1.65	22100	2250	1.99	2 -	6165DB	- 143	B-110	B-126	B-145									
			29500	3010	1.99	29500	3010	2.24	2 -	6170DB	- 143	B-110	B-126	B-145									
			29500	3010	1.99	29500	3010	2.40	2 -	6170DC	- 143	B-111	B-127	B-146									
			29500	3010	2.24	29500	3010	2.24	2 -	6175DB	- 143	B-110	B-126	B-145									
			29500	3010	2.48	29500	3010	2.99	2 -	6175DC	- 143	B-111	B-127	B-146									

- "*2" indicate models manufactured with reducer and motor separately mounted on a common baseplate (horizontal shaft direction) or on an adaptor (vertical shaft direction). Consult us for details, including dimensions.
- Allowable radial load (Pro) is the value at the midpoint of the slow speed shaft.
- "*3" indicate models with reduction ratios equal to nominal ratio. Refer to Table A-3 "6000SK Series (Actual Reduction Ratio)" on page A-4 for actual reduction ratio. Indicated reduction ratio is the same as actual reduction ratio for other models.
- Maintain torque load during operation within "Output torque" in the table for models with "*" in the SF column. They cannot be operated with 100% motor rating.

Selection Tables Gearmotors

1.5 kW	Hz		50Hz		60Hz	
	P		4	6	4	6
	n ₁	r/min	1450	980	1750	1165

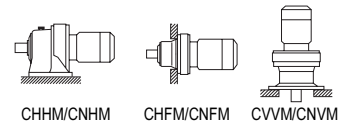

50Hz						60Hz					Nomenclature			Page of Dimension Sheet			
Output Speed n ₂ r/min	Output Torque Tout		Allowable Radial Load Pro		SF	Output Speed n ₂ r/min	Output Torque Tout		Allowable Radial Load Pro		SF	Input Capacity Symbol	Frame Size	Reduction Ratio	CNHM	CNFM	CNVM
	N·m	kgf·m	N	kgf			N·m	kgf·m	N	kgf							
8.79	940	95.8	14700	1500	*1	10.6	1220	124	14700	1500	*1	2 -	6135DB	- 165	B-109	B-125	B-144
	15500	1580	16000	1630	1.12		6145DC	- 165	B-109	B-125	B-144						
	22100	2250	22100	2250	1.07		2 - 6160DA	- 165	B-110	B-126	B-145						
	22100	2250	22100	2250	1.20		2 - 6160DB	- 165	B-110	B-126	B-145						
	22100	2250	22100	2250	1.43		2 - 6165DB	- 165	B-110	B-126	B-145						
	29500	3010	29500	3010	1.72		2 - 6170DB	- 165	B-110	B-126	B-145						
	29500	3010	29500	3010	2.15		2 - 6175DB	- 165	B-110	B-126	B-145						
	41700	4250	41700	4250	2.24		2 - 6180DA	- 165	B-110	B-126	B-145						
	41700	4250	41700	4250	2.77		2 - 6180DB	- 165	B-111	B-127	B-146						
7.44	1230	125	16000	1630	*1	8.97	1440	146	16000	1630	*1	2 -	6140DB	- 195	B-109	B-125	B-144
	22100	2250	22100	2250	1.01		2 - 6160DA	- 195	B-110	B-126	B-145						
	22100	2250	22100	2250	1.01		2 - 6160DB	- 195	B-110	B-126	B-145						
	22100	2250	22100	2250	1.07		2 - 6165DA	- 195	B-110	B-126	B-145						
	22100	2250	22100	2250	1.21		2 - 6165DB	- 195	B-110	B-126	B-145						
	29500	3010	29500	3010	1.46		2 - 6170DB	- 195	B-110	B-126	B-145						
	29500	3010	29500	3010	1.82		2 - 6175DB	- 195	B-110	B-126	B-145						
	41700	4250	41700	4250	2.24		2 - 6180DA	- 195	B-110	B-126	B-145						
	41700	4250	41700	4250	2.34		2 - 6180DB	- 195	B-111	B-127	B-146						
41700	4250	41700	4250	2.84	2 - 6185DB	- 195	B-111	B-127	B-146								
6.28	1340	136	16000	1630	*1	7.58	1700	173	16000	1630	*1	2 -	6145DB	- 231	B-109	B-125	B-144
	22100	2250	22100	2250	1.02		2 - 6165DB	- 231	B-110	B-126	B-145						
	29500	3010	29500	3010	1.07		2 - 6170DA	- 231	B-110	B-126	B-145						
	29500	3010	29500	3010	1.23		2 - 6170DB	- 231	B-110	B-126	B-145						
	29500	3010	29500	3010	1.53		2 - 6175DB	- 231	B-110	B-126	B-145						
	41700	4250	41700	4250	1.97		2 - 6180DA	- 231	B-110	B-126	B-145						
	41700	4250	41700	4250	1.97		2 - 6180DB	- 231	B-111	B-127	B-146						
	41700	4250	41700	4250	2.24		2 - 6185DA	- 231	B-110	B-126	B-145						
	41700	4250	41700	4250	2.43		2 - 6185DB	- 231	B-111	B-127	B-146						
5.31	1760	179	22100	2250	*1	6.41	2010	205	22100	2250	*1	2 -	6160DA	- 273	B-110	B-126	B-145
	29500	3010	29500	3010	1.04		2 - 6170DB	- 273	B-110	B-126	B-145						
	29500	3010	29500	3010	1.07		2 - 6175DA	- 273	B-110	B-126	B-145						
	29500	3010	29500	3010	1.30		2 - 6175DB	- 273	B-110	B-126	B-145						
	41700	4250	41700	4250	1.67		2 - 6180DA	- 273	B-110	B-126	B-145						
	41700	4250	41700	4250	2.06		2 - 6185DA	- 273	B-110	B-126	B-145						
	41700	4250	41700	4250	2.06		2 - 6185DB	- 273	B-111	B-127	B-146						
	59000	6010	59000	6010	2.63		2 - 6190DA	- 273	B-111	B-128	B-147						
	4.55	1760	179	22100	2250		*1	5.49	2350	240	22100						
29500						3010						29500	3010	1.07	2 - 6175DA	- 319	B-110
29500		3010	29500	3010	1.11	2 - 6175DB	- 319		B-110	B-126	B-145						
41700		4250	41700	4250	1.43	2 - 6180DA	- 319		B-110	B-126	B-145						
41700		4250	41700	4250	1.76	2 - 6185DA	- 319		B-110	B-126	B-145						
59000		6010	59000	6010	2.25	2 - 6190DA	- 319		B-111	B-128	B-147						
59000		6010	59000	6010	2.81	2 - 6195DA	- 319		B-111	B-128	B-147						

1. Combinations in **bold** are the recommended models for operations for 10 hours/day with uniform load (service factor is about 1.0 for motor rating at 50Hz).
2. Motor slippage may affect n₁ and n₂. Refer to technical data for details.
3. CNHM, CHHM, CNFM, CHFM, CNVM, and CVVM indicate types. Refer to page B-10 for details.
4. Lubrication method is different for each model. Refer to "Lubrication" section in page F-4~F-5 for details.
5. "6" at the end of "input capacity symbol" indicates models with 6P motor. Other models come with 4P motor.

Selection Tables Gearmotors

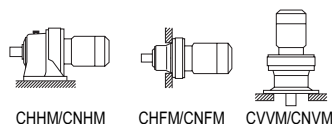

1.5 kW	Hz		50Hz		60Hz	
	P		4	6	4	6
	n ₁	r/min	1450	980	1750	1165

n₁: Motor Speed

50Hz						60Hz					Nomenclature			Page of Dimension Sheet			
Output Speed n ₂ r/min	Output Torque T _{out}		Allowable Radial Load Pro		SF	Output Speed n ₂ r/min	Output Torque T _{out}		Allowable Radial Load Pro		SF	Input Capacity - Symbol	Frame Size	Reduction Ratio	CNHM	CNFM	CNVM
	N·m	kgf·m	N	kgf			N·m	kgf·m	N	kgf							
3.85	2100	214	22100	2250	*1	4.64	2100	214	22100	2250	*1	2 -	6165DA	- 377	B-110	B-126	B-145
	2530	258	29500	3010	*1		2530	258	29500	3010	*1	2 -	6170DA	- 377	B-110	B-126	B-145
	3350	342	29500	3010	0.94		29500	3010	1.07	2 -	6175DA	- 377	B-110	B-126	B-145		
			29500	3010	0.94		29500	3010	1.13	2 -	6175DB	- 377	B-110	B-126	B-145		
			41700	4250	1.21		41700	4250	1.46	2 -	6180DA	- 377	B-110	B-126	B-145		
			41700	4250	1.49		41700	4250	1.80	2 -	6185DA	- 377	B-110	B-126	B-145		
59000	6010	1.90	59000	6010	2.30	2 -	6190DA	- 377	B-111	B-128	B-147						
59000	6010	2.37	59000	6010	2.87	2 -	6195DA	- 377	B-111	B-128	B-147						
3.07	3150	321	29500	3010	*1	3.70	3150	321	29500	3010	*1	2 -	6175DA	- 473	B-110	B-126	B-145
	4210	429	41700	4250	1.19		41700	4250	1.43	2 -	6185DA	- 473	B-110	B-126	B-145		
			59000	6010	1.52		59000	6010	1.83	2 -	6190DA	- 473	B-111	B-128	B-147		
59000	6010	1.89	59000	6010	2.28	2 -	6195DA	- 473	B-111	B-128	B-147						
2.59	3150	321	29500	3010	*1	3.13	3150	321	29500	3010	*1	2 -	6175DA	- 559	B-110	B-126	B-145
	4060	414	41700	4250	*1		4060	414	41700	4250	*1	2 -	6180DA	- 559	B-110	B-126	B-145
	4970	507	41700	4250	1.01		41700	4250	1.21	2 -	6185DA	- 559	B-110	B-126	B-145		
59000			6010	1.28	59000	6010	1.55	2 -	6190DA	- 559	B-111	B-128	B-147				
59000			6010	1.60	59000	6010	1.93	2 -	6195DA	- 559	B-111	B-128	B-147				
2.23	4050	413	41700	4250	*1	2.70	4050	413	41700	4250	*1	2 -	6180DA	- 649	B-110	B-126	B-145
	5770	588	41300	4210	0.87		41700	4250	1.05	2 -	6185DA	- 649	B-110	B-126	B-145		
			58700	5990	1.11		59000	6010	1.33	2 -	6190DA	- 649	B-111	B-128	B-147		
58700	5990	1.38	59000	6010	1.66	2 -	6195DA	- 649	B-111	B-128	B-147						
1.98	4060	414	41700	4250	*1	2.39	4060	414	41700	4250	*1	2 -	6180DA	- 731	B-110	B-126	B-145
	5000	510	41700	4250	*1		5000	510	41700	4250	*1	2 -	6185DA	- 731	B-110	B-126	B-145
	6500	663	59000	6010	1.22		5390	549	59000	6010	1.48	2 -	6195DA	- 731	B-111	B-128	B-147
1.72	5000	510	41700	4250	*1	2.08	5000	510	41700	4250	*1	2 -	6185DA	- 841	B-110	B-126	B-145
	7480	762	59000	6010	1.06		59000	6010	1.28	2 -	6195DA	- 841	B-111	B-128	B-147		
			59000	6010	1.06		59000	6010	1.28	2 -	6195DB	- 841	B-112	B-128	B-147		
6380	650	58600	5970	*1	1.74	6380	650	58600	5970	*1	2 -	6190DA	- 1003	B-111	B-128	B-147	
8920	909	57900	5900	0.89		7390	753	58300	5940	1.08	2 -	6195DA	- 1003	B-111	B-128	B-147	
1.16	7960	811	59000	6010	*1	1.40	7960	811	59000	6010	*1	2 -	6195DA	- 1247	B-111	B-128	B-147
	8760	893	84100	8570	*1		8360	853	84100	8570	*1	2 -	6205DA	- 1479	B-112	B-129	B-148
0.980	13200	1340	104000	10600	0.86	1.18	10900	1110	104000	10600	1.03	2 -	6215DA	- 1479	B-112	B-129	B-148
0.784	9300	948	84100	8570	*1		9300	948	84100	8570	*1	2 -	6205DA	- 1849	B-112	B-129	B-148
	12700	1290	104000	10600	*1	0.946	12700	1290	104000	10600	*1	2 -	6215DA	- 1849	B-112	B-129	B-148
16400	1680	145000	14800	0.97	13600		1390	145000	14800	1.17	2 -	6225DA	- 1849	B-113	B-130	B-149	
0.702	9300	948	84100	8570	*1	0.847	9300	948	84100	8570	*1	2 -	6205DA	- 2065	B-112	B-129	B-148
	12700	1290	104000	10600	*1		12700	1290	104000	10600	*1	2 -	6215DA	- 2065	B-112	B-129	B-148
	18400	1870	145000	14800	0.86		15200	1550	145000	14800	1.04	2 -	6225DA	- 2065	B-113	B-130	B-149
0.572	12700	1290	104000	10600	*1	0.690	12700	1290	104000	10600	*1	2 -	6215DA	- 2537	B-112	B-129	B-148
	15900	1620	145000	14800	*1		15900	1620	145000	14800	*1	2 -	6225DA	- 2537	B-113	B-130	B-149
0.476	11300	1150	104000	10600	*1	0.575	11300	1150	104000	10600	*1	2 -	6215DA	- 3045	B-112	B-129	B-148
	15100	1540	145000	14800	*1		15100	1540	145000	14800	*1	2 -	6225DA	- 3045	B-113	B-130	B-149
0.417	12700	1290	104000	10600	*1	0.503	12700	1290	104000	10600	*1	2 -	6215DA	- 3481	B-112	B-129	B-148
	15900	1620	145000	14800	*1		15900	1620	145000	14800	*1	2 -	6225DA	- 3481	B-113	B-130	B-149
0.327	11300	1150	104000	10600	*1	0.394	11300	1150	104000	10600	*1	2 -	6215DA	- 4437	B-112	B-129	B-148
	15100	1540	145000	14800	*1		15100	1540	145000	14800	*1	2 -	6225DA	- 4437	B-113	B-130	B-149
0.282	12700	1290	104000	10600	*1	0.341	12700	1290	104000	10600	*1	2 -	6215DA	- 5133	B-112	B-129	B-148
	15900	1620	145000	14800	*1		15900	1620	145000	14800	*1	2 -	6225DA	- 5133	B-113	B-130	B-149

GEARMOTORS
Selection Tables
1.5 kW

- "*2" indicate models manufactured with reducer and motor separately mounted on a common baseplate (horizontal shaft direction) or on an adaptor (vertical shaft direction). Consult us for details, including dimensions.
- Allowable radial load (Pro) is the value at the midpoint of the slow speed shaft.
- "*3" indicate models with reduction ratios equal to nominal ratio. Refer to Table A-3 "6000SK Series (Actual Reduction Ratio)" on page A-4 for actual reduction ratio. Indicated reduction ratio is the same as actual reduction ratio for other models.
- Maintain torque load during operation within "Output torque" in the table for models with "*" in the SF column. They cannot be operated with 100% motor rating.

Selection Tables Gearmotors

GEARMOTORS

Selection Tables
1.5 kW, 2.2 kW

1.5 kW	Hz		50Hz		60Hz	
	P		4	6	4	6
	n ₁	r/min	1450	980	1750	1165

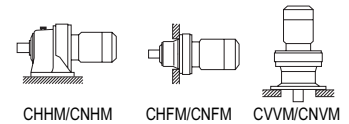

50Hz						60Hz					Nomenclature			Page of Dimension Sheet			
Output Speed n ₂	Output Torque Tout		Allowable Radial Load Pro		SF	Output Speed n ₂	Output Torque Tout		Allowable Radial Load Pro		SF	Input Capacity Symbol	Frame Size	Reduction Ratio	CNHM	CNFM	CNVM
r/min	N·m	kgf·m	N	kgf		r/min	N·m	kgf·m	N	kgf							
0.235	11300	1150	104000	10600	*1	0.283	11300	1150	104000	10600	*1	2 -	6215DA	-6177	B-112	B-129	B-148
	15100	1540	145000	14800	*1		15100	1540	145000	14800	*1		2 -	6225DA	-6177	B-113	B-130
0.192	11300	1150	104000	10600	*1	0.231	11300	1150	104000	10600	*1	2 -	6215DA	-7569	B-112	B-129	B-148
	15100	1540	145000	14800	*1		15100	1540	145000	14800	*1		2 -	6225DA	-7569	B-113	B-130

2.2 kW	Hz		50Hz		60Hz	
	P		4	6	4	6
	n ₁	r/min	1450	980	1750	1165

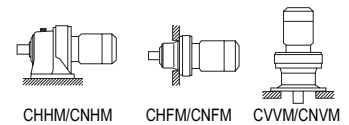

50Hz						60Hz					Nomenclature			Page of Dimension Sheet						
Output Speed n ₂	Output Torque Tout		Allowable Radial Load Pro		SF	Output Speed n ₂	Output Torque Tout		Allowable Radial Load Pro		SF	Input Capacity Symbol	Frame Size	Reduction Ratio	CNHM	CNFM	CNVM			
r/min	N·m	kgf·m	N	kgf		r/min	N·m	kgf·m	N	kgf										
580	34.4	3.51	2050	209	1.09	700	28.5	2.91	1970	201	1.09	3 -	6090SK	- 2.5 *3	B-98	-	B-133			
			2050	209	1.23				1970	201	1.23				3 -	6095SK	- 2.5 *3	B-98	-	B-133
			2050	209	1.45				1970	201	1.45				3 -	6100SK	- 2.5 *3	B-99	-	B-134
			2050	209	1.70				1970	201	1.70				3 -	6105SK	- 2.5 *3	B-99	-	B-134
			2790	284	2.34				2650	270	2.34				3 -	6110SK	- 2.5 *3	B-99	-	B-134
			2790	284	2.93				2650	270	2.93				3 -	6115SK	- 2.5 *3	B-99	-	B-134
483	41.3	4.21	2120	216	1.06	583	34.2	3.49	2040	208	1.06	3 -	6090SK	- 3 *3	B-98	-	B-133			
			2120	216	1.20				2040	208	1.20				3 -	6095SK	- 3 *3	B-98	-	B-133
			2120	216	1.50				2040	208	1.50				3 -	6100SK	- 3 *3	B-99	-	B-134
			2120	216	1.76				2040	208	1.76				3 -	6105SK	- 3 *3	B-99	-	B-134
			2960	302	2.40				2820	287	2.40				3 -	6110SK	- 3 *3	B-99	-	B-134
2960	302	3.00	2820	287	3.00	3 -	6115SK	- 3 *3	B-99	-	B-134									
363	55.1	5.61	2300	234	1.06	438	45.6	4.65	2240	228	1.06	3 -	6090SK	- 4 *3	B-98	-	B-133			
			2300	234	1.20				2240	228	1.20				3 -	6095SK	- 4 *3	B-98	-	B-133
			2300	234	1.46				2240	228	1.46				3 -	6100SK	- 4 *3	B-99	-	B-134
			2300	234	1.72				2240	228	1.72				3 -	6105SK	- 4 *3	B-99	-	B-134
			3170	323	2.43				3010	307	2.43				3 -	6110SK	- 4 *3	B-99	-	B-134
3170	323	3.04	3010	307	3.04	3 -	6115SK	- 4 *3	B-99	-	B-134									
290	68.8	7.02	2420	247	1.02	350	57.0	5.81	2330	238	1.02	3 -	6090SK	- 5 *3	B-98	-	B-133			
			2420	247	1.20				2330	238	1.20				3 -	6095SK	- 5 *3	B-98	-	B-133
			2420	247	1.43				2330	238	1.43				3 -	6100SK	- 5 *3	B-99	-	B-134
			2420	247	1.68				2330	238	1.68				3 -	6105SK	- 5 *3	B-99	-	B-134
			3330	339	2.09				3180	324	2.09				3 -	6110SK	- 5 *3	B-99	-	B-134
3330	339	2.62	3180	324	2.62	3 -	6115SK	- 5 *3	B-99	-	B-134									
242	82.6	8.42	2410	246	1.03	292	68.4	6.98	2370	242	1.03	3 -	6095SK	- 6 *3	B-98	-	B-133			
			2410	246	1.21				2370	242	1.21				3 -	6100SK	- 6 *3	B-99	-	B-134
			2410	246	1.43				2370	242	1.43				3 -	6105SK	- 6 *3	B-99	-	B-134
			3520	359	1.92				3370	344	1.92				3 -	6110SK	- 6 *3	B-99	-	B-134
			3520	359	2.40				3370	344	2.40				3 -	6115SK	- 6 *3	B-99	-	B-134
			4090	417	1.07				3860	393	1.07				3 -	6100	- 6	B-101	B-117	B-136
			4090	417	1.45				3860	393	1.45				3 -	6105	- 6	B-101	B-117	B-136
			4640	473	1.61				4370	445	1.61				3 -	6110	- 6	B-101	B-117	B-136
			4640	473	1.78				4370	445	1.78				3 -	6115	- 6	B-101	B-117	B-136
5260	536	2.30	4950	505	2.30	3 -	6120	- 6	B-101	B-117	B-136									

1. Combinations in **bold** are the recommended models for operations for 10 hours/day with uniform load (service factor is about 1.0 for motor rating at 50Hz).
2. Motor slippage may affect n₁ and n₂. Refer to technical data for details.
3. CNHM, CHHM, CNFM, CHFM, CNVM, and CVVM indicate types. Refer to page B-10 for details.
4. Lubrication method is different for each model. Refer to "Lubrication" section in page F-4~F-5 for details.
5. "6" at the end of "input capacity symbol" indicates models with 6P motor. Other models come with 4P motor.

Selection Tables Gearmotors

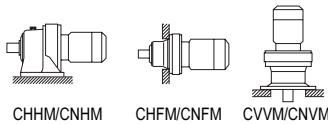

2.2 kW	Hz		50Hz		60Hz	
	P		4	6	4	6
	n ₁	r/min	1450	980	1750	1165

n₁: Motor Speed

50Hz						60Hz						Nomenclature			Page of Dimension Sheet								
Output Speed n ₂ r/min	Output Torque Tout		Allowable Radial Load Pro		SF	Output Speed n ₂ r/min	Output Torque Tout		Allowable Radial Load Pro		SF	Input Capacity Symbol	Frame Size	Reduction Ratio	CNHM	CNFM	CNVM						
	N·m	kgf·m	N	kgf			N·m	kgf·m	N	kgf								CHHM	CHFM	CVVM			
181	110	11.2	2540	259	0.80	219	91.2	9.30	2500	255	0.80	3	- 6095SK	- 8 *3	B-98	-	B-133						
			2540	259	1.13				2500	255	1.13							3	- 6105SK	- 8 *3	B-99	-	B-134
			3730	380	1.68				3580	365	1.68							3	- 6110SK	- 8 *3	B-99	-	B-134
			3730	380	2.10				3580	365	2.10							3	- 6115SK	- 8 *3	B-99	-	B-134
			4560	465	1.07				4300	438	1.07							3	- 6100	- 8	B-101	B-117	B-136
			4560	465	1.45				4300	438	1.45							3	- 6105	- 8	B-101	B-117	B-136
			5170	527	1.61				4870	496	1.61							3	- 6110	- 8	B-101	B-117	B-136
145	138	14.0	2610	266	0.80	175	114	11.6	2580	263	0.80	3	- 6095SK	- 10 *3	B-98	-	B-133						
			2610	266	1.00				2580	263	1.00							3	- 6105SK	- 10 *3	B-99	-	B-134
			3960	404	1.39				3820	389	1.39							3	- 6110SK	- 10 *3	B-99	-	B-134
			3960	404	1.74				3820	389	1.74							3	- 6115SK	- 10 *3	B-99	-	B-134
			5170	527	1.07				4870	497	1.07							3	- 6100	- 11	B-101	B-117	B-136
			5170	527	1.45				4870	497	1.45							3	- 6105	- 11	B-101	B-117	B-136
			5900	601	1.61				5560	567	1.61							3	- 6110	- 11	B-101	B-117	B-136
132	151	15.4	5900	601	1.61	159	125	12.8	5560	567	1.78	3	- 6115	- 11	B-101	B-117	B-136						
			6670	680	2.30				6280	640	2.30							3	- 6120	- 11	B-101	B-117	B-136
			6670	680	2.69				6280	640	2.69							3	- 6125	- 11	B-101	B-117	B-136
			5360	547	1.07				5060	516	1.07							3	- 6100	- 13	B-101	B-117	B-136
			5360	547	1.45				5060	516	1.45							3	- 6105	- 13	B-101	B-117	B-136
			6090	621	1.61				5740	586	1.61							3	- 6110	- 13	B-101	B-117	B-136
			6090	621	1.77				5740	586	1.77							3	- 6115	- 13	B-101	B-117	B-136
112	179	18.2	6890	702	2.30	135	148	15.1	6490	662	2.30	3	- 6120	- 13	B-101	B-117	B-136						
			6890	702	2.69				6490	662	2.69							3	- 6125	- 13	B-101	B-117	B-136
			5400	550	1.07				5340	544	1.07							3	- 6100	- 15	B-101	B-117	B-136
			5400	550	1.45				5340	544	1.45							3	- 6105	- 15	B-101	B-117	B-136
			6490	662	1.61				6120	624	1.61							3	- 6110	- 15	B-101	B-117	B-136
			6490	662	1.77				6120	624	1.77							3	- 6115	- 15	B-101	B-117	B-136
			7390	753	2.30				6960	710	2.30							3	- 6120	- 15	B-101	B-117	B-136
96.7	206	21.0	7390	753	2.69	117	171	17.4	6960	710	2.69	3	- 6125	- 15	B-101	B-117	B-136						
			5400	550	1.12				5400	550	1.12							3	- 6105	- 17	B-101	B-117	B-136
			6550	668	1.45				6180	630	1.45							3	- 6110	- 17	B-101	B-117	B-136
			6550	668	1.77				6180	630	1.77							3	- 6115	- 17	B-101	B-117	B-136
			7460	760	2.22				7030	716	2.30							3	- 6120	- 17	B-101	B-117	B-136
			7460	760	2.57				7030	716	2.57							3	- 6125	- 17	B-101	B-117	B-136
			5400	550	1.04				5400	550	1.06							3	- 6105	- 21	B-101	B-117	B-136
69.0	289	29.5	6920	706	1.24	83.3	240	24.4	6540	667	1.24	3	- 6110	- 21	B-101	B-117	B-136						
			6920	706	1.41				6540	667	1.41							3	- 6115	- 21	B-101	B-117	B-136
			8180	834	1.80				7710	786	1.80							3	- 6120	- 21	B-101	B-117	B-136
			8180	834	2.18				7710	786	2.22							3	- 6125	- 21	B-101	B-117	B-136
			9580	976	2.70				9020	919	2.79							3	- 6130	- 21	B-102	B-118	B-137
			7010	715	1.01				6620	675	1.01							3	- 6115	- 25	B-101	B-117	B-136
			8560	873	1.40				8070	823	1.40							3	- 6120	- 25	B-101	B-117	B-136
58.0	344	35.1	8560	873	1.80	70.0	285	29.1	8070	823	1.80	3	- 6125	- 25	B-101	B-117	B-136						
			9950	1010	2.27				9370	955	2.35							3	- 6130	- 25	B-102	B-118	B-137
			9950	1010	2.61				9370	955	2.70							3	- 6135	- 25	B-102	B-118	B-137
			7160	730	1.01				6800	693	1.01							3	- 6115	- 29	B-101	B-117	B-136
			8880	905	1.30				8380	854	1.36							3	- 6120	- 29	B-101	B-117	B-136
			8880	905	1.58				8380	854	1.71							3	- 6125	- 29	B-101	B-117	B-136
			10500	1070	1.95				9850	1000	2.04							3	- 6130	- 29	B-102	B-118	B-137
50.0	399	40.7	10500	1070	2.22	60.3	331	33.7	9850	1000	2.56	3	- 6135	- 29	B-102	B-118	B-137						
			15000	1530	2.70				14200	1450	2.70							3	- 6140	- 29	B-102	B-118	B-137

GEARMOTORS
Selection Tables
2.2 kW

- "*2" indicate models manufactured with reducer and motor separately mounted on a common baseplate (horizontal shaft direction) or on an adaptor (vertical shaft direction). Consult us for details, including dimensions.
- Allowable radial load (Pro) is the value at the midpoint of the slow speed shaft.
- "*3" indicate models with reduction ratios equal to nominal ratio. Refer to Table A-3 "6000SK Series (Actual Reduction Ratio)" on page A-4 for actual reduction ratio. Indicated reduction ratio is the same as actual reduction ratio for other models.
- Maintain torque load during operation within "Output torque" in the table for models with "*" in the SF column. They cannot be operated with 100% motor rating.

Selection Tables Gearmotors

2.2 kW		n ₁ : Motor Speed							
		Hz		50Hz		60Hz			
		P		4	6	4	6		
n ₁ r/min		1450		980		1750		1165	

50Hz					60Hz					Nomenclature			Page of Dimension Sheet				
Output Speed n ₂ r/min	Output Torque Tout N·m	kgf·m	Allowable Radial Load Pro N	SF	Output Speed n ₂ r/min	Output Torque Tout N·m	kgf·m	Allowable Radial Load Pro N	SF	Input Capacity Symbol	Frame Size	Reduction Ratio	CNHM	CNFM	CNVM		
			kgf					kgf					CHHM	CHFM	CVVM		
41.4	482	49.1	4960	0.82	50.0	399	40.7	7230	0.82	3 -	6115	- 35	B-101	B-117	B-136		
			9350	1.08				8830	1.13				6120	35	B-101	B-117	B-136
			9350	1.31				8830	1.45				6125	35	B-101	B-117	B-136
			11000	1.62				10300	1.69				6130	35	B-102	B-118	B-137
			11000	1.87				10300	1.93				6135	35	B-102	B-118	B-137
			16000	2.37				15200	2.37				6140	35	B-102	B-118	B-137
33.7	592	60.3	16000	2.85	40.7	490	50.0	15200	3.42	3 -	6145	- 35	B-102	B-118	B-137		
			9810	1.06				9380	1.08				6125	43	B-101	B-117	B-136
			11800	1.32				11100	1.36				6130	43	B-102	B-118	B-137
			11800	1.52				11100	1.71				6135	43	B-102	B-118	B-137
			16000	1.79				15900	1.79				6140	43	B-102	B-118	B-137
			16000	2.12				15900	2.45				6145	43	B-102	B-118	B-137
28.4	702	71.6	20600	2.93	34.3	582	59.3	19300	3.39	3 -	6160	- 43	B-103	B-119	B-138		
			9810	0.90				9760	1.04				6125	51	B-101	B-117	B-136
			12200	1.11				11500	1.15				6130	51	B-102	B-118	B-137
			12200	1.16				11500	1.33				6135	51	B-102	B-118	B-137
			16000	1.56				16000	1.56				6140	51	B-102	B-118	B-137
			16000	1.68				16000	1.92				6145	51	B-102	B-118	B-137
24.6	812	82.8	21300	2.50	29.7	673	68.6	20100	2.61	3 -	6160	- 51	B-103	B-119	B-138		
			21300	2.99				20100	3.42				6165	51	B-103	B-119	B-138
			12800	1.11				12100	1.15				6135	59	B-102	B-118	B-137
			16000	1.35				16000	1.35				6140	59	B-102	B-118	B-137
			16000	1.45				16000	1.66				6145	59	B-102	B-118	B-137
			22100	2.01				22100	2.01				6160	59	B-103	B-119	B-138
20.4	977	99.6	22100	2.59	24.6	810	82.5	22100	2.61	3 -	6165	- 59	B-103	B-119	B-138		
			13500	0.92				12800	0.98				6135	71	B-102	B-118	B-137
			16000	1.10				16000	1.10				6140	71	B-102	B-118	B-137
			16000	1.19				16000	1.38				6145	71	B-102	B-118	B-137
			22100	1.58				22100	1.58				6160	71	B-103	B-119	B-138
			22100	2.15				22100	2.57				6165	71	B-103	B-119	B-138
16.7	1200	122	16000	0.98	20.1	992	101	16000	1.13	3 -	6145	- 87	B-102	B-118	B-137		
			22100	1.46				22100	1.58				6160	87	B-103	B-119	B-138
			22100	1.71				22100	1.77				6165	87	B-103	B-119	B-138
			780	*1				780	*1				6130DC	104	B-109	B-125	B-144
			940	*1				940	*1				6135DC	104	B-109	B-125	B-144
			16000	1.01				16000	1.22				6145DC	104	B-109	B-125	B-144
13.9	1360	138	22100	1.29	16.8	1120	115	22100	1.53	3 -	6160DB	- 104	B-110	B-126	B-145		
			22100	1.29				22100	1.56				6160DC	104	B-111	B-127	B-146
			22100	1.53				22100	1.53				6165DB	104	B-110	B-126	B-145
			22100	1.55				22100	1.87				6165DC	104	B-111	B-127	B-146
			29500	1.86				29400	2.25				6170DC	104	B-111	B-127	B-146
			29500	2.32				29400	2.80				6175DC	104	B-111	B-127	B-146
41300	2.99	38800	3.61	6180DB	104	B-111	B-127	B-146									

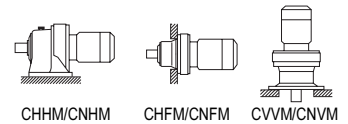

GEARMOTORS
Selection Tables
2.2 kW

1. Combinations in **bold** are the recommended models for operations for 10 hours/day with uniform load (service factor is about 1.0 for motor rating at 50Hz).
2. Motor slippage may affect n₁ and n₂. Refer to technical data for details.
3. CNHM, CHHM, CNFM, CHFM, and CVVM indicate types. Refer to page B-10 for details.
4. Lubrication method is different for each model. Refer to "Lubrication" section in page F-4~F-5 for details.
5. "6" at the end of "input capacity symbol" indicates models with 6P motor. Other models come with 4P motor.

Selection Tables Gearmotors

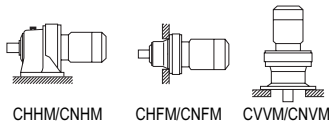

2.2 kW	Hz		50Hz		60Hz	
	P		4	6	4	6
	n ₁	r/min	1450	980	1750	1165

n₁: Motor Speed

50Hz					60Hz					Nomenclature			Page of Dimension Sheet			
Output Speed n ₂ r/min	Output Torque Tout		Allowable Radial Load Pro		SF	Output Speed n ₂ r/min	Output Torque Tout		Allowable Radial Load Pro		Input Capacity Symbol	Frame Size	Reduction Ratio	CNHM	CNFM	CNVM
	N·m	kgf·m	N	kgf			N·m	kgf·m	N	kgf						
12.0	940	95.8	14700	1500	*1	14.5	940	95.8	14700	1500	*1	3 - 6135DC	- 121	B-109	B-125	B-144
	1230	125	16000	1630	*1		1230	125	16000	1630	*1	3 - 6140DC	- 121	B-109	B-125	B-144
	1290	132	16000	1630	*1		1290	132	16000	1630	*1	3 - 6145DC	- 121	B-109	B-125	B-144
			15300	1560	0.82				16000	1630	0.98	3 - 6145DC	- 121	B-109	B-125	B-144
			22100	2250	1.11				22100	2250	1.34	3 - 6160DB	- 121	B-110	B-126	B-145
			22100	2250	1.11				22100	2250	1.34	3 - 6160DC	- 121	B-111	B-127	B-146
			22100	2250	1.33				22100	2250	1.53	3 - 6165DB	- 121	B-110	B-126	B-145
	1580	161	22100	2250	1.33		1310	133	22100	2250	1.61	3 - 6165DC	- 121	B-111	B-127	B-146
			29500	3010	1.53				29500	3010	1.53	3 - 6170DB	- 121	B-110	B-126	B-145
			29500	3010	1.60				29500	3010	1.94	3 - 6170DC	- 121	B-111	B-127	B-146
		29500	3010	2.00			29500	3010	2.41	3 - 6175DC	- 121	B-111	B-127	B-146		
		41700	4250	2.57			41300	4210	3.11	3 - 6180DB	- 121	B-111	B-127	B-146		
10.1	1230	125	16000	1630	*1	12.2	1230	125	16000	1630	*1	3 - 6140DC	- 143	B-109	B-125	B-144
	1370	140	15900	1620	*1		1370	140	15900	1620	*1	3 - 6145DC	- 143	B-109	B-125	B-144
			22100	2250	1.13				22100	2250	1.36	3 - 6165DB	- 143	B-110	B-126	B-145
			29500	3010	1.35				29500	3010	1.53	3 - 6170DB	- 143	B-110	B-126	B-145
			29500	3010	1.35				29500	3010	1.64	3 - 6170DC	- 143	B-111	B-127	B-146
	1860	190	29500	3010	1.53		1550	158	29500	3010	1.53	3 - 6175DB	- 143	B-110	B-126	B-145
			29500	3010	1.69				29500	3010	2.04	3 - 6175DC	- 143	B-111	B-127	B-146
			41700	4250	2.18				41700	4250	2.63	3 - 6180DB	- 143	B-111	B-127	B-146
			41700	4250	2.63				41700	4250	3.17	3 - 6185DB	- 143	B-111	B-127	B-146
			59000	6010	2.84				59000	6010	2.84	3 - 6190DA	- 143	B-111	B-128	B-147
8.79	1230	125	16000	1630	*1	10.6	1230	125	16000	1630	*1	3 - 6140DC	- 165	B-109	B-125	B-144
	1360	138	16000	1630	*1		1360	138	16000	1630	*1	3 - 6145DC	- 165	B-109	B-125	B-144
	1760	179	22100	2250	*1		1760	179	22100	2250	*1	3 - 6160DB	- 165	B-110	B-126	B-145
			22100	2250	0.98				22100	2250	1.18	3 - 6165DB	- 165	B-110	B-126	B-145
			29500	3010	1.18				29500	3010	1.42	3 - 6170DB	- 165	B-110	B-126	B-145
			29500	3010	1.46				29500	3010	1.53	3 - 6175DB	- 165	B-110	B-126	B-145
			29500	3010	1.46				29500	3010	1.77	3 - 6175DC	- 165	B-111	B-127	B-146
	2150	219	41700	4250	1.53		1780	182	41700	4250	1.53	3 - 6180DA	- 165	B-110	B-126	B-145
			41700	4250	1.89				41700	4250	2.28	3 - 6180DB	- 165	B-111	B-127	B-146
			41700	4250	2.29				41700	4250	2.76	3 - 6185DB	- 165	B-111	B-127	B-146
		59000	6010	2.84			59000	6010	2.84	3 - 6190DA	- 165	B-111	B-128	B-147		
		59000	6010	2.97			59000	6010	3.58	3 - 6190DB	- 165	B-112	B-128	B-147		
7.44	1760	179	22100	2250	*1	8.97	1760	179	22100	2250	*1	3 - 6160DB	- 195	B-110	B-126	B-145
	2100	214	22100	2250	*1		2100	214	22100	2250	*1	3 - 6165DB	- 195	B-110	B-126	B-145
			22100	2250	0.83				22100	2250	1.00	3 - 6165DB	- 195	B-110	B-126	B-145
			29500	3010	0.98				29500	3010	1.20	3 - 6170DB	- 195	B-110	B-126	B-145
			29500	3010	1.24				29500	3010	1.50	3 - 6175DB	- 195	B-110	B-126	B-145
			41700	4250	1.53				41700	4250	1.53	3 - 6180DA	- 195	B-110	B-126	B-145
	2540	259	41700	4250	1.60		2110	215	41700	4250	1.93	3 - 6180DB	- 195	B-111	B-127	B-146
			41700	4250	1.94				41700	4250	2.34	3 - 6185DB	- 195	B-111	B-127	B-146
			59000	6010	2.51				59000	6010	2.84	3 - 6190DA	- 195	B-111	B-128	B-147
			59000	6010	2.51				59000	6010	3.03	3 - 6190DB	- 195	B-112	B-128	B-147
			59000	6010	2.56				59000	6010	2.84	3 - 6195DA	- 195	B-111	B-128	B-147
			84100	8570	2.84				84100	8570	2.84	3 - 6205DA	- 195	B-112	B-129	B-148

GEARMOTORS
Selection Tables
2.2 kW

- "*2" indicate models manufactured with reducer and motor separately mounted on a common baseplate (horizontal shaft direction) or on an adaptor (vertical shaft direction). Consult us for details, including dimensions.
- Allowable radial load (Pro) is the value at the midpoint of the slow speed shaft.
- "*3" indicate models with reduction ratios equal to nominal ratio. Refer to Table A-3 "6000SK Series (Actual Reduction Ratio)" on page A-4 for actual reduction ratio. Indicated reduction ratio is the same as actual reduction ratio for other models.
- Maintain torque load during operation within "Output torque" in the table for models with "*" in the SF column. They cannot be operated with 100% motor rating.

Selection Tables Gearmotors

2.2 kW	Hz		50Hz		60Hz	
	P		4	6	4	6
	n ₁	r/min	1450	980	1750	1165

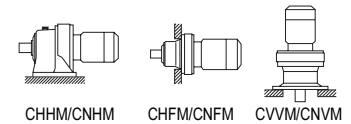

50Hz						60Hz						Nomenclature			Page of Dimension Sheet																	
Output Speed n ₂ r/min	Output Torque Tout		Allowable Radial Load Pro		SF	Output Speed n ₂ r/min	Output Torque Tout		Allowable Radial Load Pro		SF	Input Capacity Symbol	Frame Size	Reduction Ratio	CNHM	CNFM	CNVM															
	N·m	kgf·m	N	kgf			N·m	kgf·m	N	kgf																						
6.28	1760	179	22100	2250	*1	7.58	1760	179	22100	2250	*1	3 -	6160DB	- 231	B-110	B-126	B-145															
	2100	214	22100	2250	*1		2100	214	22100	2250	*1				3 -	6165DB	- 231	B-110	B-126	B-145												
			29500	3010	1.05					29500	3010				1.26	3 -	6175DB	- 231	B-110	B-126	B-145											
			41700	4250	1.34					41700	4250				1.53	3 -	6180DA	- 231	B-110	B-126	B-145											
			41700	4250	1.34					41700	4250				1.62	3 -	6180DB	- 231	B-111	B-127	B-146											
			41700	4250	1.53					41700	4250				1.53	3 -	6185DA	- 231	B-110	B-126	B-145											
	3010	307	41700	4250	1.66		2500	254	41700	4250	2.00				2.00	3 -	6185DB	- 231	B-111	B-127	B-146											
			59000	6010	2.12														59000	6010	2.56	3 -	6190DA	- 231	B-111	B-128	B-147					
			59000	6010	2.64														59000	6010	2.84	3 -	6195DA	- 231	B-111	B-128	B-147					
			59000	6010	2.64														59000	6010	3.19	3 -	6195DB	- 231	B-112	B-128	B-147					
		2100	214	22100	2250	*1						6.41	2100	214					22100	2250	*1	3 -	6165DB	- 273	B-110	B-126	B-145					
2530	258	29500	3010	*1	2530	258							29500	3010					*1	3 -	6170DB				- 273	B-110	B-126	B-145				
		29500	3010	0.88			29500	3010	1.07	3 -	6175DB		- 273	B-110	B-126	B-145																
		41700	4250	1.14			41700	4250	1.37	3 -	6180DA		- 273	B-110	B-126	B-145																
		41700	4250	1.40			41700	4250	1.53	3 -	6185DA		- 273	B-110	B-126	B-145																
		41700	4250	1.40	2950	301	41700	4250	1.70	1.70	3 -		6185DB	- 273	B-111	B-127	B-146															
3560	363	41700	4250	1.40											59000	6010	2.16	3 -	6190DA	- 273	B-111				B-128	B-147						
		59000	6010	1.79											59000	6010	2.16	3 -	6190DA	- 273	B-111				B-128	B-147						
		59000	6010	2.24											59000	6010	2.70	3 -	6195DA	- 273	B-111				B-128	B-147						
		84100	8570	2.35											84100	8570	2.66	3 -	6205DA	- 273	B-112				B-129	B-148						
		84100	8570	2.61								84100			8570	3.14	3 -	6205DB	- 273	B-112	B-129	B-148										
4.55	2530	258	29500	3010	*1	5.49	2530	258	29500	3010	*1	3 -	6170DB	- 319	B-110	B-126	B-145															
	3150	321	29500	3010	*1		3150	321	29500	3010	*1				3 -	6175DB	- 319	B-110	B-126	B-145												
			41700	4250	1.20				41700	4250	1.45				3 -	6185DA	- 319	B-110	B-126	B-145												
			59000	6010	1.53				59000	6010	1.85				3 -	6190DA	- 319	B-111	B-128	B-147												
			59000	6010	1.91		3450	351	59000	6010	2.31				2.31	3 -	6195DA	- 319	B-111	B-128	B-147											
	4160	424	59000	6010	1.91														84100	8570	2.20	3 -	6205DA	- 319	B-112	B-129	B-148					
			84100	8570	1.94														84100	8570	2.20	3 -	6205DA	- 319	B-112	B-129	B-148					
			84100	8570	2.22														84100	8570	2.68	3 -	6205DB	- 319	B-112	B-129	B-148					
			3150	321	29500														3010	*1	4.64	3150	321	29500	3010	*1	3 -	6175DB	- 377	B-110	B-126	B-145
	4050	413	41700	4250	*1														4050	413		41700	4250	*1	3 -	6180DA				- 377	B-110	B-126
		41700	4250	1.02			41700	4250	1.23	3 -	6185DA	- 377	B-110	B-126	B-145																	
		59000	6010	1.30			59000	6010	1.57	3 -	6190DA	- 377	B-111	B-128	B-147																	
		59000	6010	1.62	4070	415	59000	6010	1.95	1.95	3 -	6195DA	- 377	B-111	B-128	B-147																
4920	501	59000	6010	1.62										84100	8570	1.97	3 -	6205DA	- 377	B-112		B-129	B-148									
		84100	8570	1.74										84100	8570	1.97	3 -	6205DA	- 377	B-112		B-129	B-148									
		84100	8570	1.88										84100	8570	2.27	3 -	6205DB	- 377	B-112		B-129	B-148									
		104000	10600	2.57										104000	10600	3.11	3 -	6215DA	- 377	B-112		B-129	B-148									
		4060	414	41700										4250	*1	3.70	4060	414	41700	4250		*1	3 -	6180DA	- 473	B-110				B-126	B-145	
5000	510	41700	4250	*1	5000	510	41700	4250	*1	3 -	6185DA	- 473	B-110	B-126	B-145																	
		41700	4250	0.81			41700	4250	0.98	3 -	6185DA	- 473	B-110	B-126	B-145																	
		59000	6010	1.03			59000	6010	1.25	3 -	6190DA	- 473	B-111	B-128	B-147																	
		59000	6010	1.29	5110	521	59000	6010	1.56	1.56	3 -	6195DA	- 473	B-111	B-128		B-147															
6170	629	84100	8570	1.34										84100	8570		1.52	3 -	6205DA	- 473	B-112	B-129				B-148						
		84100	8570	1.51										84100	8570		1.82	3 -	6205DB	- 473	B-112	B-129				B-148						
		104000	10600	2.05										104000	10600		2.48	3 -	6215DA	- 473	B-112	B-129				B-148						
		145000	14800	2.59										145000	14800		3.13	3 -	6225DA	- 473	B-113	B-130				B-149						
		5000	510	41700										4250	*1		3.13	5000	510	41700	4250	*1				3 -	6185DA	- 559	B-110	B-126	B-145	
		59000	6010	1.09			59000	6010	1.32	3 -	6195DA	- 559	B-111	B-128	B-147																	
		84100	8570	1.20			84100	8570	1.36	3 -	6205DA	- 559	B-112	B-129	B-148																	
		84100	8570	1.28	6040	616	84100	8570	1.54	1.54	3 -	6205DB	- 559	B-112	B-129	B-148																
7290	743	104000	10600	1.74										104000	10600	2.09		3 -	6215DA	- 559	B-112	B-129	B-148									
		145000	14800	2.19										145000	14800	2.65		3 -	6225DA	- 559	B-113	B-130	B-149									
		179000	18200	2.81										179000	18200	3.39		3 -	6235DA	- 559	B-114	B-131	B-150									

1. Combinations in **bold** are the recommended models for operations for 10 hours/day with uniform load (service factor is about 1.0 for motor rating at 50Hz).
2. Motor slippage may affect n₁ and n₂. Refer to technical data for details.
3. CNHM, CHHM, CNFM, CHFM, CNVM, and CVVM indicate types. Refer to page B-10 for details.
4. Lubrication method is different for each model. Refer to "Lubrication" section in page F-4~F-5 for details.
5. "6" at the end of "input capacity symbol" indicates models with 6P motor. Other models come with 4P motor.

Selection Tables Gearmotors

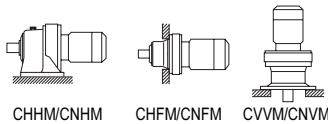

2.2 kW	Hz		50Hz		60Hz	
	P		4	6	4	6
	n ₁	r/min	1450	980	1750	1165

n₁: Motor Speed



50Hz					60Hz					Nomenclature			Page of Dimension Sheet									
Output Speed n ₂ r/min	Output Torque T _{out}		Allowable Radial Load Pro		SF	Output Speed n ₂ r/min	Output Torque T _{out}		Allowable Radial Load Pro		Input Capacity Symbol	Frame Size	Reduction Ratio	CNHM	CNFM	CNVM						
	N·m	kgf·m	N	kgf			N·m	kgf·m	N	kgf							CHHM	CHFM	CVVM			
2.23	5000	510	41600	4240	*1	2.70	5000	510	41600	4240	*1	3 - 6185DA	- 649	B-110	B-126	B-145						
	6380	650	58600	5970	*1		6380	650	58600	5970	*1	3 - 6190DA	- 649	B-111	B-128	B-147						
	8460	863	58000	5910	0.94		7010	715	58400	5950	1.14	3 - 6195DA	- 649	B-111	B-128	B-147						
			84100	8570	0.98				84100	8570	1.11	3 - 6205DA	- 649	B-112	B-129	B-148						
			84100	8570	1.10				84100	8570	1.33	3 - 6205DB	- 649	B-112	B-129	B-148						
			104000	10600	1.49				104000	10600	1.80	3 - 6215DA	- 649	B-112	B-129	B-148						
145000	14800	1.88	145000	14800	2.26	3 - 6225DA	- 649	B-113	B-130	B-149												
179000	18200	2.42	179000	18200	2.92	3 - 6235DA	- 649	B-114	B-131	B-150												
1.98	6380	650	59000	6010	*1	2.39	6380	650	59000	6010	*1	3 - 6190DA	- 731	B-111	B-128	B-147						
	9530	972	58500	5970	0.84		7900	805	59000	6010	1.01	3 - 6195DA	- 731	B-111	B-128	B-147						
			84100	8570	0.98				84100	8570	1.15	3 - 6205DA	- 731	B-112	B-129	B-148						
			84100	8570	0.98				84100	8570	1.18	3 - 6205DB	- 731	B-112	B-129	B-148						
			104000	10600	1.33				104000	10600	1.60	3 - 6215DA	- 731	B-112	B-129	B-148						
	145000	14800	1.68	145000	14800		2.03	3 - 6225DA	- 731	B-113	B-130	B-149										
179000	18200	2.15	179000	18200	2.60	3 - 6235DA	- 731	B-114	B-131	B-150												
208000	21200	2.71	208000	21200	3.27	3 - 6245DA	- 731	B-114	B-131	B-150												
1.72	6380	650	59000	6010	*1	2.08	6380	650	59000	6010	*1	3 - 6190DA	- 841	B-111	B-128	B-147						
	7960	811	59000	6010	*1		7960	811	59000	6010	*1	3 - 6195DA	- 841	B-111	B-128	B-147						
	11000	1120	84100	8570	0.84		9090	926	84100	8570	1.02	3 - 6205DA	- 841	B-112	B-129	B-148						
			104000	10600	1.15				104000	10600	1.39	3 - 6215DA	- 841	B-112	B-129	B-148						
			145000	14800	1.37				145000	14800	1.65	3 - 6225DA	- 841	B-113	B-130	B-149						
			179000	18200	1.72				179000	18200	2.08	3 - 6235DA	- 841	B-114	B-131	B-150						
208000	21200	2.35	208000	21200	2.84	3 - 6245DA	- 841	B-114	B-131	B-150												
1.45	7960	811	58100	5930	*1	1.74	7960	811	58100	5930	*1	3 - 6195DA	- 1003	B-111	B-128	B-147						
	9300	948	84100	8570	*1		9060	923	84100	8570	*1	3 - 6205DA	- 1003	B-112	B-129	B-148						
	13100	1330	104000	10600	0.97		10800	1100	104000	10600	1.17	3 - 6215DA	- 1003	B-112	B-129	B-148						
			145000	14800	1.21				145000	14800	1.46	3 - 6225DA	- 1003	B-113	B-130	B-149						
			179000	18200	1.57				179000	18200	1.89	3 - 6235DA	- 1003	B-114	B-131	B-150						
			208000	21200	1.97				208000	21200	2.38	3 - 6245DA	- 1003	B-114	B-131	B-150						
1.16	9300	948	84100	8570	*1	1.40	9300	948	84100	8570	*1	3 - 6205DA	- 1247	B-112	B-129	B-148						
	12700	1290	104000	10600	*1		12700	1290	104000	10600	*1	3 - 6215DA	- 1247	B-112	B-129	B-148						
	16300	1660	145000	14800	0.98		13500	1370	145000	14800	1.19	3 - 6225DA	- 1247	B-113	B-130	B-149						
			179000	18200	1.26				179000	18200	1.52	3 - 6235DA	- 1247	B-114	B-131	B-150						
			208000	21200	1.59				208000	21200	1.91	3 - 6245DA	- 1247	B-114	B-131	B-150						
			0.980	11300	1150				104000	10600	*1	1.18	11300	1150	104000	10600	*1	3 - 6215DA	- 1479	B-112	B-129	B-148
15100	1540	145000		14800	*1	15100	1540	145000	14800	*1	3 - 6225DA		- 1479	B-113	B-130	B-149						
19300	1970	179000		18200	0.89	16000	1630	179000	18200	1.07	3 - 6235DA		- 1479	B-114	B-131	B-150						
		208000		21200	1.17			208000	21200	1.42	3 - 6245DA		- 1479	B-114	B-131	B-150						
		0.784		16000	1630			145000	14800	*1	0.946		16000	1630	145000	14800	*1	3 - 6225DA	- 1849	B-113	B-130	B-149
				24100	2460			179000	18200	0.85			20000	2040	179000	18200	1.03	3 - 6235DA	- 1849	B-114	B-131	B-150
208000	21200		1.07	208000	21200	1.29	3 - 6245DA	- 1849	B-114	B-131		B-150										
0.702	15900		1620	145000	14800	*1	0.847	15900	1620	145000		14800	*1	3 - 6225DA	- 2065	B-113	B-130	B-149				
	20500		2090	179000	18200	*1		20500	2090	179000		18200	*1	3 - 6235DA	- 2065	B-114	B-131	B-150				
	26900		2750	208000	21200	0.96		22300	2270	208000		21200	1.16	3 - 6245DA	- 2065	B-114	B-131	B-150				
	0.572	20500	2090	179000	18200	*1		0.690	20500	2090	179000	18200	*1	3 - 6235DA	- 2537	B-114	B-131	B-150				
		25800	2630	208000	21200	*1			25800	2630	208000	21200	*1	3 - 6245DA	- 2537	B-114	B-131	B-150				
		0.476	17200	1750	179000	18200			*1	0.575	17200	1750	179000	18200	*1	3 - 6235DA	- 3045	B-114	B-131	B-150		
22600			2310	208000	21200	*1	22600		2310		208000	21200	*1	3 - 6245DA	- 3045	B-114	B-131	B-150				
0.417			20500	2090	179000	18200	*1		0.503		20500	2090	179000	18200	*1	3 - 6235DA	- 3481	B-114	B-131	B-150		
			25800	2630	208000	21200	*1				25800	2630	208000	21200	*1	3 - 6245DA	- 3481	B-114	B-131	B-150		
	0.327		17200	1750	179000	18200	*1	0.394			17200	1750	179000	18200	*1	3 - 6235DA	- 4437	B-114	B-131	B-150		
			22600	2310	208000	21200	*1				22600	2310	208000	21200	*1	3 - 6245DA	- 4437	B-114	B-131	B-150		
		0.282	20500	2090	179000	18200	*1			0.341	20500	2090	179000	18200	*1	3 - 6235DA	- 5133	B-114	B-131	B-150		
			25800	2630	208000	21200	*1				25800	2630	208000	21200	*1	3 - 6245DA	- 5133	B-114	B-131	B-150		
0.235			17200	1750	179000	18200	*1		0.283		17200	1750	179000	18200	*1	3 - 6235DA	- 6177	B-114	B-131	B-150		
			22600	2310	208000	21200	*1				22600	2310	208000	21200	*1	3 - 6245DA	- 6177	B-114	B-131	B-150		

- "*2" indicate models manufactured with reducer and motor separately mounted on a common baseplate (horizontal shaft direction) or on an adaptor (vertical shaft direction). Consult us for details, including dimensions.
- Allowable radial load (Pro) is the value at the midpoint of the slow speed shaft.
- "*3" indicate models with reduction ratios equal to nominal ratio. Refer to Table A-3 "6000SK Series (Actual Reduction Ratio)" on page A-4 for actual reduction ratio. Indicated reduction ratio is the same as actual reduction ratio for other models.
- Maintain torque load during operation within "Output torque" in the table for models with "*"1" in the SF column. They cannot be operated with 100% motor rating.

GEARMOTORS
Selection Tables
2.2 kW

Selection Tables Gearmotors

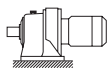
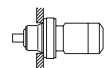
2.2 kW		n ₁ : Motor Speed							
		Hz		50Hz		60Hz			
		P		4	6	4	6		
n ₁ r/min		1450		980		1750		1165	



CHHM/CNHM CHFM/CNFM CVVM/CNVM

50Hz					60Hz					Nomenclature			Page of Dimension Sheet				
Output Speed n ₂	Output Torque Tout		Allowable Radial Load Pro		SF	Output Speed n ₂	Output Torque Tout		Allowable Radial Load Pro		SF	Input Capacity - Symbol	Frame - Size	Reduction - Ratio	CNHM	CNFM	CNVM
r/min	N·m	kgf·m	N	kgf		r/min	N·m	kgf·m	N	kgf							
0.192	17200	1750	179000	18200	*1	0.231	17200	1750	179000	18200	*1	3 -	6235DA	- 7569	B-114	B-131	B-150
	22600	2310	208000	21200	*1		22600	2310	208000	21200	*1	3 -	6245DA	- 7569	B-114	B-131	B-150

GEARMOTORS

Selection Tables
2.2 kW, 3.0 kW

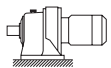
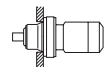
3.0 kW		n ₁ : Motor Speed							
		Hz		50Hz		60Hz			
		P		4	6	4	6		
n ₁ r/min		1450		980		1750		1165	





CHHM/CNHM CHFM/CNFM CVVM/CNVM

50Hz					60Hz					Nomenclature			Page of Dimension Sheet				
Output Speed n ₂	Output Torque Tout		Allowable Radial Load Pro		SF	Output Speed n ₂	Output Torque Tout		Allowable Radial Load Pro		SF	Input Capacity - Symbol	Frame - Size	Reduction - Ratio	CNHM	CNFM	CNVM
r/min	N·m	kgf·m	N	kgf		r/min	N·m	kgf·m	N	kgf							
580	46.9	4.78	1930	197	1.06	700	38.9	3.96	1870	191	1.06	4 -	6100SK	- 2.5 *3	B-99	-	B-134
			1930	197	1.25				1870	191	1.25	4 -	6105SK	- 2.5 *3	B-99	-	B-134
			2700	275	1.72				2570	262	1.72	4 -	6110SK	- 2.5 *3	B-99	-	B-134
			2700	275	2.15				2570	262	2.15	4 -	6115SK	- 2.5 *3	B-99	-	B-134
483	56.3	5.74	1980	202	1.10	583	46.7	4.76	1920	196	1.10	4 -	6100SK	- 3 *3	B-99	-	B-134
			1980	202	1.29				1920	196	1.29	4 -	6105SK	- 3 *3	B-99	-	B-134
			2850	291	1.76				2730	278	1.76	4 -	6110SK	- 3 *3	B-99	-	B-134
			2850	291	2.20				2730	278	2.20	4 -	6115SK	- 3 *3	B-99	-	B-134
363	75.1	7.65	2130	217	1.07	583	62.2	6.34	2080	212	1.07	4 -	6100SK	- 4 *3	B-99	-	B-134
			2130	217	1.26				2080	212	1.26	4 -	6105SK	- 4 *3	B-99	-	B-134
			3040	310	1.78				2900	296	1.78	4 -	6110SK	- 4 *3	B-99	-	B-134
			3040	310	2.23				2900	296	2.23	4 -	6115SK	- 4 *3	B-99	-	B-134
290	93.9	9.57	2210	225	1.23	350	77.8	7.93	2160	220	1.23	4 -	6105SK	- 5 *3	B-99	-	B-134
			2160	220	1.26				2160	220	1.26	4 -	6110SK	- 5 *3	B-99	-	B-134
			3180	324	1.54				3040	310	1.54	4 -	6115SK	- 5 *3	B-99	-	B-134
			3180	324	1.92				3040	310	1.92	4 -	6115SK	- 5 *3	B-99	-	B-134
242	113	11.5	2190	223	1.05	292	93.3	9.51	2160	220	1.05	4 -	6105SK	- 6 *3	B-99	-	B-134
			2190	223	1.41				2160	220	1.41	4 -	6110SK	- 6 *3	B-99	-	B-134
			3330	339	1.76				3210	327	1.76	4 -	6115SK	- 6 *3	B-99	-	B-134
			3330	339	1.76				3210	327	1.76	4 -	6115SK	- 6 *3	B-99	-	B-134
			4610	470	1.18				4340	443	1.18	4 -	6110	- 6	B-101	B-117	B-136
			4610	470	1.31				4340	443	1.31	4 -	6115	- 6	B-101	B-117	B-136
			5230	534	1.69				4930	502	1.69	4 -	6120	- 6	B-101	B-117	B-136
			5230	534	2.32				4930	502	1.94	4 -	6125	- 6	B-101	B-117	B-136
181	150	15.3	2170	221	0.83	219	124	12.7	2190	223	0.83	4 -	6105SK	- 8 *3	B-99	-	B-134
			3470	354	1.23				3370	344	1.23	4 -	6110SK	- 8 *3	B-99	-	B-134
			3470	354	1.54				3370	344	1.54	4 -	6115SK	- 8 *3	B-99	-	B-134
			5130	523	1.18				4830	493	1.18	4 -	6110	- 8	B-101	B-117	B-136
			5130	523	1.31				4830	493	1.31	4 -	6115	- 8	B-101	B-117	B-136
			5830	595	1.69				5490	560	1.69	4 -	6120	- 8	B-101	B-117	B-136
5830	595	2.32	5490	560	2.32	4 -	6125	- 8	B-101	B-117	B-136						
145	188	19.1	3650	372	1.02	175	156	15.9	3550	362	1.02	4 -	6110SK	- 10 *3	B-99	-	B-134
			3650	372	1.27				3550	362	1.27	4 -	6115SK	- 10 *3	B-99	-	B-134
132	206	21.0	5840	595	1.18	159	171	17.4	5510	561	1.18	4 -	6110	- 11	B-101	B-117	B-136
			5840	595	1.31				5510	561	1.31	4 -	6115	- 11	B-101	B-117	B-136
			6620	675	1.69				6240	636	1.69	4 -	6120	- 11	B-101	B-117	B-136
			6620	675	1.97				6240	636	1.97	4 -	6125	- 11	B-101	B-117	B-136

1. Combinations in **bold** are the recommended models for operations for 10 hours/day with uniform load (service factor is about 1.0 for motor rating at 50Hz).
2. Motor slippage may affect n₁ and n₂. Refer to technical data for details.
3. CNHM, CHHM, CNFM, CHFM, CNVM, and CVVM indicate types. Refer to page B-10 for details.
4. Lubrication method is different for each model. Refer to "Lubrication" section in page F-4~F-5 for details.
5. "6" at the end of "input capacity symbol" indicates models with 6P motor. Other models come with 4P motor.

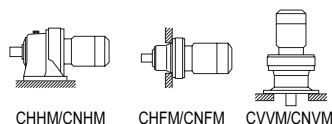
Selection Tables Gearmotors



3.0 kW	Hz		50Hz		60Hz	
	P		4	6	4	6
	n ₁	r/min	1450	980	1750	1165

n₁: Motor Speed

50Hz					60Hz					Nomenclature			Page of Dimension Sheet							
Output Speed n ₂ r/min	Output Torque Tout		Allowable Radial Load Pro		SF	Output Speed n ₂ r/min	Output Torque Tout		Allowable Radial Load Pro		SF	Input Capacity Symbol	Frame Size	Reduction Ratio	CNHM	CNFM	CNVM			
	N·m	kgf·m	N	kgf			N·m	kgf·m	N	kgf								CHHM	CHFM	CVVM
112	244	24.9	6020	614	1.18	135	202	20.6	5690	580	1.18	4 -	6110	- 13	B-101	B-117	B-136			
			6020	614	1.30				5690	580	1.30				4 -	6115	- 13	B-101	B-117	B-136
			6830	696	1.69				6440	657	1.69				4 -	6120	- 13	B-101	B-117	B-136
			6830	696	1.97				6440	657	1.97				4 -	6125	- 13	B-101	B-117	B-136
96.7	282	28.7	6410	653	1.18	117	233	23.8	6050	617	1.18	4 -	6110	- 15	B-101	B-117	B-136			
			6410	653	1.30				6050	617	1.30				4 -	6115	- 15	B-101	B-117	B-136
			7320	747	1.69				6910	704	1.69				4 -	6120	- 15	B-101	B-117	B-136
			7320	747	1.97				6910	704	1.97				4 -	6125	- 15	B-101	B-117	B-136
			8290	845	2.59				7810	796	2.59				4 -	6130	- 15	B-102	B-118	B-137
			8290	845	2.99				7810	796	2.99				4 -	6135	- 15	B-102	B-118	B-137
85.3	319	32.5	6460	659	1.06	103	264	27.0	6110	622	1.06	4 -	6110	- 17	B-101	B-117	B-136			
			6460	659	1.30				6110	622	1.30				4 -	6115	- 17	B-101	B-117	B-136
			7390	753	1.63				6970	710	1.69				4 -	6120	- 17	B-101	B-117	B-136
			7390	753	1.89				6970	710	1.89				4 -	6125	- 17	B-101	B-117	B-136
			8900	907	2.42				8380	854	2.42				4 -	6130	- 17	B-102	B-118	B-137
			8900	907	2.76				8380	854	2.76				4 -	6135	- 17	B-102	B-118	B-137
69.0	394	40.2	6800	693	1.04	83.3	327	33.3	6440	657	1.04	4 -	6115	- 21	B-101	B-117	B-136			
			8090	825	1.32				7640	779	1.32				4 -	6120	- 21	B-101	B-117	B-136
			8090	825	1.60				7640	779	1.63				4 -	6125	- 21	B-101	B-117	B-136
			9500	969	1.98				8960	913	2.05				4 -	6130	- 21	B-102	B-118	B-137
			9500	969	2.24				8960	913	2.51				4 -	6135	- 21	B-102	B-118	B-137
			14000	1430	2.89				13200	1350	2.89				4 -	6140	- 21	B-102	B-118	B-137
58.0	469	47.8	8450	861	1.03	70.0	389	39.6	7980	814	1.03	4 -	6120	- 25	B-101	B-117	B-136			
			8450	861	1.32				7980	814	1.32				4 -	6125	- 25	B-101	B-117	B-136
			9860	1010	1.66				9300	948	1.72				4 -	6130	- 25	B-102	B-118	B-137
			9860	1010	1.92				9300	948	1.98				4 -	6135	- 25	B-102	B-118	B-137
			14700	1490	2.30				13900	1410	2.30				4 -	6140	- 25	B-102	B-118	B-137
			14700	1490	2.64				13900	1410	2.64				4 -	6145	- 25	B-102	B-118	B-137
50.0	544	55.5	8750	892	1.16	60.3	451	46.0	8280	844	1.26	4 -	6125	- 29	B-101	B-117	B-136			
			10400	1060	1.43				9770	996	1.49				4 -	6130	- 29	B-102	B-118	B-137
			10400	1060	1.63				9770	996	1.88				4 -	6135	- 29	B-102	B-118	B-137
			15000	1530	1.98				14200	1450	1.98				4 -	6140	- 29	B-102	B-118	B-137
			15000	1530	2.51				14200	1450	2.51				4 -	6145	- 29	B-102	B-118	B-137
			9190	937	0.96				8700	887	1.06				4 -	6125	- 35	B-101	B-117	B-136
41.4	657	67.0	10900	1110	1.19	50.0	544	55.5	10300	1050	1.24	4 -	6130	- 35	B-102	B-118	B-137			
			10900	1110	1.37				10300	1050	1.42				4 -	6135	- 35	B-102	B-118	B-137
			16000	1630	1.74				15200	1550	1.74				4 -	6140	- 35	B-102	B-118	B-137
			16000	1630	2.09				15200	1550	2.51				4 -	6145	- 35	B-102	B-118	B-137
			19100	1950	2.67				18000	1840	3.22				4 -	6160	- 35	B-103	B-119	B-138
			11600	1180	1.12				11000	1120	1.26				4 -	6135	- 43	B-102	B-118	B-137
33.7	807	82.3	16000	1630	1.31	40.7	669	68.2	15800	1610	1.31	4 -	6140	- 43	B-102	B-118	B-137			
			16000	1630	1.56				15800	1610	1.80	4 -	6145	- 43	B-102	B-118	B-137			
			20400	2080	2.15				19200	1960	2.48	4 -	6160	- 43	B-103	B-119	B-138			
			20400	2080	2.60				19200	1960	2.64	4 -	6165	- 43	B-103	B-119	B-138			
28.4	957	97.6	12000	1220	0.85	34.3	793	80.9	11400	1160	0.98	4 -	6135	- 51	B-102	B-118	B-137			
			16000	1630	1.14				16000	1630	1.14	4 -	6140	- 51	B-102	B-118	B-137			
			16000	1630	1.23				16000	1630	1.41	4 -	6145	- 51	B-102	B-118	B-137			
			21200	2160	1.83				20000	2040	1.92	4 -	6160	- 51	B-103	B-119	B-138			
			21200	2160	2.19				20000	2040	2.51	4 -	6165	- 51	B-103	B-119	B-138			
			24100	2450	2.55				22700	2310	2.80	4 -	6170	- 51	B-103	B-119	B-138			

GEARMOTORS
Selection Tables
3.0 kW

- "*2" indicate models manufactured with reducer and motor separately mounted on a common baseplate (horizontal shaft direction) or on an adaptor (vertical shaft direction). Consult us for details, including dimensions.
- Allowable radial load (Pro) is the value at the midpoint of the slow speed shaft.
- "*3" indicate models with reduction ratios equal to nominal ratio. Refer to Table A-3 "6000SK Series (Actual Reduction Ratio)" on page A-4 for actual reduction ratio. Indicated reduction ratio is the same as actual reduction ratio for other models.
- Maintain torque load during operation within "Output torque" in the table for models with "*" in the SF column. They cannot be operated with 100% motor rating.

Selection Tables Gearmotors

3.0 kW	Hz		50Hz		60Hz	
	P		4	6	4	6
	n ₁	r/min	1450	980	1750	1165

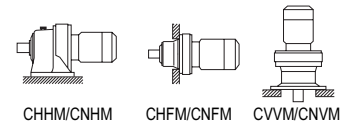

50Hz						60Hz						Nomenclature			Page of Dimension Sheet							
Output Speed n ₂ r/min	Output Torque Tout N·m kgf·m		Allowable Radial Load Pro N kgf		SF	Output Speed n ₂ r/min	Output Torque Tout N·m kgf·m		Allowable Radial Load Pro N kgf		SF	Input Capacity Symbol	Frame Size	Reduction Ratio	CNHM CHHM	CNFM CHFM	CNVM CVVM					
24.6	1110	113	12600	1280	0.81	29.7	918	93.5	11900	1210	0.84	4 -	6135	- 59	B-102	B-118	B-137					
			16000	1630	0.98				16000	1630	0.98				4 -	6140	- 59	B-102	B-118	B-137		
			16000	1630	1.06				16000	1630	1.22				4 -	6145	- 59	B-102	B-118	B-137		
			22100	2250	1.47				22100	2250	1.47				4 -	6160	- 59	B-103	B-119	B-138		
			22100	2250	1.90				22100	2250	1.92				4 -	6165	- 59	B-103	B-119	B-138		
			25200	2570	2.21				23800	2420	2.38				4 -	6170	- 59	B-103	B-119	B-138		
			25200	2570	2.76				23800	2420	2.76	4 -	6175	- 59	B-103	B-119	B-138					
20.4	1330	136	16000	1630	0.87	24.6	1100	113	16000	1630	1.01	4 -	6145	- 71	B-102	B-118	B-137					
			22100	2250	1.16				22100	2250	1.16				4 -	6160	- 71	B-103	B-119	B-138		
			22100	2250	1.58				22100	2250	1.88				4 -	6165	- 71	B-103	B-119	B-138		
			26700	2720	1.83				25100	2560	1.97				4 -	6170	- 71	B-103	B-119	B-138		
			26700	2720	2.33				25100	2560	2.38				4 -	6175	- 71	B-103	B-119	B-138		
			35900	3650	2.93				33700	3440	2.93				4 -	6180	- 71	B-104	B-120	B-139		
16.7	1630	166	22100	2250	1.07	20.1	1350	138	21900	2230	1.16	4 -	6160	- 87	B-103	B-119	B-138					
			22100	2250	1.26				21900	2230	1.30				4 -	6165	- 87	B-103	B-119	B-138		
			28600	2910	1.52				26900	2750	1.60				4 -	6170	- 87	B-103	B-119	B-138		
			28600	2910	1.87				26900	2750	1.87				4 -	6175	- 87	B-103	B-119	B-138		
			38600	3930	2.38				36300	3700	2.38				4 -	6180	- 87	B-104	B-120	B-139		
			38600	3930	2.86				36300	3700	2.86				4 -	6185	- 87	B-104	B-120	B-139		
13.9	1850	189	22100	2250	1.14	16.8	1530	156	22100	2250	1.37	4 -	6165DC	- 104	B-111	B-127	B-146					
			29500	3010	1.37				29200	2970	1.65				4 -	6170DC	- 104	B-111	B-127	B-146		
			29500	3010	1.70				29200	2970	2.06				4 -	6175DC	- 104	B-111	B-127	B-146		
			41100	4190	2.20				38700	3940	2.65				4 -	6180DB	- 104	B-111	B-127	B-146		
			41100	4190	2.65				38700	3940	3.20				4 -	6185DB	- 104	B-111	B-127	B-146		
			57400	5850	2.44				53900	5500	2.44				4 -	6190DA	- 104	B-111	B-128	B-147		
			57400	5850	2.44				53900	5500	2.44	4 -	6195DA	- 104	B-111	B-128	B-147					
12.0	2150	219	1760	179	22100	2250	*1	14.5	1780	182	22100	2250	*1	4 -	6160DC	- 121	B-111	B-127	B-146			
					22100	2250	0.98				22100	2250	1.18				4 -	6165DC	- 121	B-111	B-127	B-146
					29500	3010	1.18				29500	3010	1.42				4 -	6170DC	- 121	B-111	B-127	B-146
					29500	3010	1.46				29500	3010	1.77				4 -	6175DC	- 121	B-111	B-127	B-146
					41700	4250	1.89				41200	4200	2.28				4 -	6180DB	- 121	B-111	B-127	B-146
					41700	4250	2.23				41200	4200	2.70				4 -	6185DB	- 121	B-111	B-127	B-146
		59000	6010	2.97	57500	5860	3.58	4 -	6190DB	- 121	B-112	B-128	B-147									
10.1	1760	179	22100	2250	*1	12.2	2110	215	22100	2250	*1	4 -	6160DC	- 143	B-111	B-127	B-146					
			2100	214	22100				2250	*1	2100				214	22100	2250	*1	4 -	6165DC	- 143	B-111
			22100	2250	0.83					22100	2250				1.00	4 -	6165DC	- 143	B-111	B-127	B-146	
			29500	3010	0.98					29500	3010				1.20	4 -	6170DC	- 143	B-111	B-127	B-146	
			29500	3010	1.24					29500	3010				1.50	4 -	6175DC	- 143	B-111	B-127	B-146	
		2540	259	41700	4250		1.60		2110	215	41700				4250	1.93	4 -	6180DB	- 143	B-111	B-127	B-146
	41700			4250	1.93		41700	4250			2.33				4 -	6185DB	- 143	B-111	B-127	B-146		
	59000			6010	2.08		59000	6010			2.08				4 -	6190DA	- 143	B-111	B-128	B-147		
	59000			6010	2.51		59000	6010			3.03				4 -	6190DB	- 143	B-112	B-128	B-147		
	59000			6010	3.00		59000	6010			3.62				4 -	6195DB	- 143	B-112	B-128	B-147		

1. Combinations in **bold** are the recommended models for operations for 10 hours/day with uniform load (service factor is about 1.0 for motor rating at 50Hz).
2. Motor slippage may affect n₁ and n₂. Refer to technical data for details.
3. CNHM, CHHM, CNFM, CHFM, CNVM, and CVVM indicate types. Refer to page B-10 for details.
4. Lubrication method is different for each model. Refer to "Lubrication" section in page F-4~F-5 for details.
5. "6" at the end of "input capacity symbol" indicates models with 6P motor. Other models come with 4P motor.

Selection Tables Gearmotors

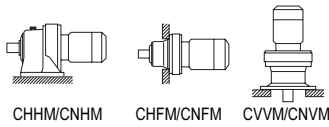

3.0 kW	Hz		50Hz		60Hz	
	P		4	6	4	6
	n ₁	r/min	1450	980	1750	1165

n₁: Motor Speed

50Hz						60Hz					Nomenclature			Page of Dimension Sheet							
Output Speed n ₂ r/min	Output Torque Tout		Allowable Radial Load Pro		SF	Output Speed n ₂ r/min	Output Torque Tout		Allowable Radial Load Pro		SF	Input Capacity - Symbol	Frame Size	Reduction Ratio	CNHM	CNFM	CNVM				
	N·m	kgf·m	N	kgf			N·m	kgf·m	N	kgf								CHHM	CHFM	CVVM	
8.79	2100	214	22100	2250	*1	10.6	2100	214	22100	2250	*1	4 -	6165DC	- 165	B-111	B-127	B-146				
			29500	3010	1.07				29500	3010	1.30				6175DC	- 165	B-111	B-127	B-146		
			41700	4250	1.38				41700	4250	1.67				6180DB	- 165	B-111	B-127	B-146		
	2930	299	41700	4250	1.68		41700	4250	2.02	4 -	6185DB				- 165	B-111	B-127	B-146			
			59000	6010	2.08		59000	6010	2.08	4 -	6190DA				- 165	B-111	B-128	B-147			
			59000	6010	2.17		59000	6010	2.62	4 -	6190DB				- 165	B-112	B-128	B-147			
			59000	6010	2.70		59000	6010	3.25	4 -	6195DB				- 165	B-112	B-128	B-147			
7.44	2530	258	29500	3010	*1	8.97	2530	258	29500	3010	*1	4 -	6170DC	- 195	B-111	B-127	B-146				
			29500	3010	0.91				29500	3010	1.10				6175DC	- 195	B-111	B-127	B-146		
			41700	4250	1.17				41700	4250	1.41				6180DB	- 195	B-111	B-127	B-146		
	3470	353	41700	4250	1.42		41700	4250	1.71	4 -	6185DB				- 195	B-111	B-127	B-146			
			59000	6010	1.84		59000	6010	2.08	4 -	6190DA				- 195	B-111	B-128	B-147			
			59000	6010	1.84		59000	6010	2.22	4 -	6190DB				- 195	B-112	B-128	B-147			
			59000	6010	1.88		59000	6010	2.08	4 -	6195DA				- 195	B-111	B-128	B-147			
59000	6010	2.28	59000	6010	2.75	4 -	6195DB	- 195	B-112	B-128	B-147										
		2.67	84100	8570	3.23	4 -	6205DB	- 195	B-112	B-129	B-148										
		6.28	2530	258	29500	3010	*1	7.58	2530	258	29500	3010	*1	4 -	6170DC	- 231	B-111	B-127	B-146		
					3150	321	29500				3010	*1	3150				321	29500	3010	*1	6175DC
			4110	419	41700	4250	1.22		41700	4250	1.47	4 -	6185DB				- 231	B-111	B-127	B-146	
59000	6010				1.55	59000	6010		1.87	4 -	6190DA	- 231	B-111				B-128	B-147			
59000	6010				1.94	59000	6010		2.08	4 -	6195DA	- 231	B-111				B-128	B-147			
59000	6010				1.94	59000	6010		2.34	4 -	6195DB	- 231	B-112				B-128	B-147			
84100	8570	2.26	84100	8570	2.72	4 -	6205DB	- 231	B-112	B-129	B-148										
		5.31	3150	321	29500	3010	*1	6.41	3150	321	29500	3010	*1	4 -	6175DC	- 273	B-111	B-127	B-146		
41700	4250				1.03	41700	4250				1.24	4 -	6185DB				- 273	B-111	B-127	B-146	
59000	6010		1.31	59000	6010	1.59	4 -		6190DA	- 273	B-111	B-128	B-147								
59000	6010		1.64	59000	6010	1.98	4 -		6195DA	- 273	B-111	B-128	B-147								
84100	8570		1.72	84100	8570	1.95	4 -		6205DA	- 273	B-112	B-129	B-148								
84100	8570		1.91	84100	8570	2.31	4 -		6205DB	- 273	B-112	B-129	B-148								
104000	10600		2.57	104000	10600	3.11	4 -		6215DA	- 273	B-112	B-129	B-148								
4.55	4050	413	41700	4250	*1	5.49	4050	413	41700	4250	*1	4 -	6180DB	- 319	B-111	B-127	B-146				
			41700	4250	0.88				41700	4250	1.06				6185DB	- 319	B-111	B-127	B-146		
	59000	6010	1.12	59000	6010		1.36	4 -	6190DA	- 319	B-111				B-128	B-147					
	59000	6010	1.40	59000	6010		1.69	4 -	6195DA	- 319	B-111				B-128	B-147					
	84100	8570	1.42	84100	8570		1.61	4 -	6205DA	- 319	B-112				B-129	B-148					
	84100	8570	1.63	84100	8570		1.96	4 -	6205DB	- 319	B-112				B-129	B-148					
	104000	10600	2.23	104000	10600		2.69	4 -	6215DA	- 319	B-112				B-129	B-148					
145000	14800	2.65	144000	14700	3.20	4 -	6225DA	- 319	B-113	B-130	B-149										
3.85	5000	510	41700	4250	*1	4.64	5000	510	41700	4250	*1	4 -	6185DB	- 377	B-111	B-127	B-146				
			59000	6010	1.19				59000	6010	1.43				4 -	6195DA	- 377	B-111	B-128	B-147	
	84100	8570	1.28	84100	8570		1.45	4 -	6205DA	- 377	B-112				B-129	B-148					
	84100	8570	1.38	84100	8570		1.66	4 -	6205DB	- 377	B-112				B-129	B-148					
	104000	10600	1.89	104000	10600		2.28	4 -	6215DA	- 377	B-112				B-129	B-148					
	145000	14800	2.24	145000	14800		2.71	4 -	6225DA	- 377	B-113				B-130	B-149					
	179000	18200	2.82	179000	18200		3.40	4 -	6235DA	- 377	B-114				B-131	B-150					
3.07	6380	650	59000	6010	*1	3.70	6380	650	59000	6010	*1	4 -	6190DA	- 473	B-111	B-128	B-147				
			58800	6000	0.95				59000	6010	1.14				6195DA	- 473	B-111	B-128	B-147		
	84100	8570	0.98	84100	8570		1.12	4 -	6205DA	- 473	B-112				B-129	B-148					
	84100	8570	1.11	84100	8570		1.33	4 -	6205DB	- 473	B-112				B-129	B-148					
	104000	10600	1.50	104000	10600		1.82	4 -	6215DA	- 473	B-112				B-129	B-148					
	145000	14800	1.90	145000	14800		2.30	4 -	6225DA	- 473	B-113				B-130	B-149					
	179000	18200	2.44	179000	18200		2.94	4 -	6235DA	- 473	B-114				B-131	B-150					

GEARMOTORS
Selection Tables
3.0 kW

- "*2" indicate models manufactured with reducer and motor separately mounted on a common baseplate (horizontal shaft direction) or on an adaptor (vertical shaft direction). Consult us for details, including dimensions.
- Allowable radial load (Pro) is the value at the midpoint of the slow speed shaft.
- "*3" indicate models with reduction ratios equal to nominal ratio. Refer to Table A-3 "6000SK Series (Actual Reduction Ratio)" on page A-4 for actual reduction ratio. Indicated reduction ratio is the same as actual reduction ratio for other models.
- Maintain torque load during operation within "Output torque" in the table for models with "*" in the SF column. They cannot be operated with 100% motor rating.

Selection Tables Gearmotors

3.0 kW	Hz		50Hz		60Hz	
	P		4	6	4	6
	n ₁	r/min	1450	980	1750	1165

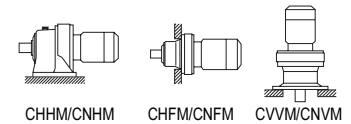

50Hz					60Hz					Nomenclature			Page of Dimension Sheet			
Output Speed n ₂ r/min	Output Torque Tout N·m	kgf·m	Allowable Radial Load Pro N	SF	Output Speed n ₂ r/min	Output Torque Tout N·m	kgf·m	Allowable Radial Load Pro N	SF	Input Capacity Symbol	Frame Size	Reduction Ratio	CNHM	CNFM	CNVM	
2.59	6380	650	59000	6010	*1	6380	650	59000	6010	*1	4 - 6190DA	- 559	B-111	B-128	B-147	
	7960	811	59000	6010	*1	7960	811	59000	6010	*1	4 - 6195DA	- 559	B-111	B-128	B-147	
	8760	893	84100	8570	*1	8230	839	84100	8570	*1	4 - 6205DA	- 559	B-112	B-129	B-148	
			58400	5950	0.80			58900	6000	0.97	4 - 6195DA	- 559	B-111	B-128	B-147	
			84100	8570	0.88			84100	8570	1.00	4 - 6205DA	- 559	B-112	B-129	B-148	
			84100	8570	0.94			84100	8570	1.13	4 - 6205DB	- 559	B-112	B-129	B-148	
		9940	1010	104000	10600	1.27	8240	840	104000	10600	1.54	4 - 6215DA	- 559	B-112	B-129	B-148
				145000	14800	1.61			145000	14800	1.94	4 - 6225DA	- 559	B-113	B-130	B-149
				179000	18200	2.06			179000	18200	2.49	4 - 6235DA	- 559	B-114	B-131	B-150
				208000	21200	2.60			208000	21200	3.13	4 - 6245DA	- 559	B-114	B-131	B-150
2.23	7960	811	58100	5930	*1	7960	811	58100	5930	*1	4 - 6195DA	- 649	B-111	B-128	B-147	
	8300	846	84100	8570	*1	7790	794	84100	8570	*1	4 - 6205DA	- 649	B-112	B-129	B-148	
			84100	8570	0.81			84100	8570	0.97	4 - 6205DB	- 649	B-112	B-129	B-148	
			104000	10600	1.10			104000	10600	1.32	4 - 6215DA	- 649	B-112	B-129	B-148	
	11500	1180	145000	14800	1.38	9560	975	145000	14800	1.66	4 - 6225DA	- 649	B-113	B-130	B-149	
			179000	18200	1.78			179000	18200	2.14	4 - 6235DA	- 649	B-114	B-131	B-150	
		208000	21200	2.24			208000	21200	2.70	4 - 6245DA	- 649	B-114	B-131	B-150		
1.98	7960	811	59000	6010	*1	7960	811	59000	6010	*1	4 - 6195DA	- 731	B-111	B-128	B-147	
	9300	948	84100	8570	*1	9060	923	84100	8570	*1	4 - 6205DA	- 731	B-112	B-129	B-148	
			104000	10600	0.97			104000	10600	1.17	4 - 6215DA	- 731	B-112	B-129	B-148	
			145000	14800	1.23			145000	14800	1.49	4 - 6225DA	- 731	B-113	B-130	B-149	
	13000	1330	179000	18200	1.58	10800	1100	179000	18200	1.90	4 - 6235DA	- 731	B-114	B-131	B-150	
		208000	21200	1.98			208000	21200	2.40	4 - 6245DA	- 731	B-114	B-131	B-150		
1.72	9230	941	84100	8570	*1	9230	941	84100	8570	*1	4 - 6205DA	- 841	B-112	B-129	B-148	
			104000	10600	0.85			104000	10600	1.02	4 - 6215DA	- 841	B-112	B-129	B-148	
			145000	14800	1.01			145000	14800	1.21	4 - 6225DA	- 841	B-113	B-130	B-149	
	15000	1520	179000	18200	1.26	12400	1260	179000	18200	1.53	4 - 6235DA	- 841	B-114	B-131	B-150	
		208000	21200	1.73			208000	21200	2.08	4 - 6245DA	- 841	B-114	B-131	B-150		
1.45	12700	1290	104000	10600	*1	12700	1290	104000	10600	*1	4 - 6215DA	- 1003	B-112	B-129	B-148	
			145000	14800	0.89			145000	14800	1.07	4 - 6225DA	- 1003	B-113	B-130	B-149	
	17800	1820	179000	18200	1.15	14800	1510	179000	18200	1.39	4 - 6235DA	- 1003	B-114	B-131	B-150	
		208000	21200	1.45			208000	21200	1.75	4 - 6245DA	- 1003	B-114	B-131	B-150		
1.16	16000	1630	145000	14800	*1	16000	1630	145000	14800	*1	4 - 6225DA	- 1247	B-113	B-130	B-149	
	22200	2260	179000	18200	0.92	18400	1870	179000	18200	1.12	4 - 6235DA	- 1247	B-114	B-131	B-150	
		208000	21200	1.16			208000	21200	1.40	4 - 6245DA	- 1247	B-114	B-131	B-150		
0.980	17200	1750	179000	18200	*1	17200	1750	179000	18200	*1	4 - 6235DA	- 1479	B-114	B-131	B-150	
	26300	2680	208000	21200	0.86	21800	2220	208000	21200	1.04	4 - 6245DA	- 1479	B-114	B-131	B-150	
0.784	20500	2090	179000	18200	*1	20500	2090	179000	18200	*1	4 - 6235DA	- 1849	B-114	B-131	B-150	
	25800	2630	208000	21200	*1	25800	2630	208000	21200	*1	4 - 6245DA	- 1849	B-114	B-131	B-150	
0.702	25800	2630	208000	21200	*1	0.847	25800	2630	208000	21200	*1	4 - 6245DA	- 2065	B-114	B-131	B-150

1. Combinations in **bold** are the recommended models for operations for 10 hours/day with uniform load (service factor is about 1.0 for motor rating at 50Hz).
2. Motor slippage may affect n₁ and n₂. Refer to technical data for details.
3. CNHM, CHHM, CNFM, CHFM, CNVM, and CVVM indicate types. Refer to page B-10 for details.
4. Lubrication method is different for each model. Refer to "Lubrication" section in page F-4~F-5 for details.
5. "6" at the end of "input capacity symbol" indicates models with 6P motor. Other models come with 4P motor.

Selection Tables Gearmotors

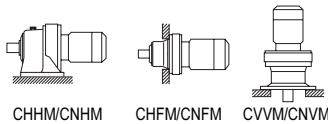

3.7 kW	Hz		50Hz		60Hz	
	P		4	6	4	6
	n ₁	r/min	1450	980	1750	1165

n₁: Motor Speed

50Hz					60Hz					Nomenclature			Page of Dimension Sheet			
Output Speed n ₂ r/min	Output Torque Tout		Allowable Radial Load Pro		SF	Output Speed n ₂ r/min	Output Torque Tout		Allowable Radial Load Pro		Input Capacity Symbol	Frame Size	Reduction Ratio	CNHM	CNFM	CNVM
	N·m	kgf·m	N	kgf			N·m	kgf·m	N	kgf						
580	57.9	5.90	1820	186	1.01	700	48.0	4.89	1790	182	1.01	5 - 6105SK	- 2.5 *3	B-99	-	B-134
			2620	267	1.39				2500	255	1.39	5 - 6110SK	- 2.5 *3	B-99	-	B-134
			2620	267	1.74				2500	255	1.74	5 - 6115SK	- 2.5 *3	B-99	-	B-134
483	69.5	7.08	1850	189	1.05	583	57.5	5.87	1810	185	1.05	5 - 6105SK	- 3 *3	B-99	-	B-134
			2770	282	1.43				2650	270	1.43	5 - 6110SK	- 3 *3	B-99	-	B-134
			2770	282	1.78				2650	270	1.78	5 - 6115SK	- 3 *3	B-99	-	B-134
363	92.6	9.44	1960	200	1.02	438	76.7	7.82	1940	198	1.02	5 - 6105SK	- 4 *3	B-99	-	B-134
			2920	298	1.45				2820	287	1.45	5 - 6110SK	- 4 *3	B-99	-	B-134
			2920	298	1.81				2820	287	1.81	5 - 6115SK	- 4 *3	B-99	-	B-134
290	116	11.8	2010	205	1.00	350	95.9	9.78	2000	204	1.00	5 - 6105SK	- 5 *3	B-99	-	B-134
			3040	310	1.25				2930	299	1.25	5 - 6110SK	- 5 *3	B-99	-	B-134
			3040	310	1.56				2930	299	1.56	5 - 6115SK	- 5 *3	B-99	-	B-134
242	139	14.2	1960	200	0.85	292	115	11.7	1970	201	0.85	5 - 6105SK	- 6 *3	B-99	-	B-134
			3160	322	1.14				3060	312	1.14	5 - 6110SK	- 6 *3	B-99	-	B-134
			3160	322	1.43				3060	312	1.43	5 - 6115SK	- 6 *3	B-99	-	B-134
			4580	467	1.06				4320	440	1.06	5 - 6115	- 6	B-101	B-117	B-136
			5210	531	1.37				4910	500	1.37	5 - 6120	- 6	B-101	B-117	B-136
181	185	18.9	5210	531	1.88	219	153	15.6	4910	500	1.57	5 - 6125	- 6	B-101	B-117	B-136
			6120	624	2.54				5760	587	2.54	5 - 6130	- 6	B-102	B-118	B-137
			3260	332	1.00				3190	325	1.00	5 - 6110SK	- 8 *3	B-99	-	B-134
			3260	332	1.25				3190	325	1.25	5 - 6115SK	- 8 *3	B-99	-	B-134
			5090	519	1.06				4800	489	1.06	5 - 6115	- 8	B-101	B-117	B-136
145	232	23.6	5800	591	1.37	175	192	19.6	5470	557	1.37	5 - 6120	- 8	B-101	B-117	B-136
			5800	591	1.88				5470	557	1.88	5 - 6125	- 8	B-101	B-117	B-136
			6820	695	2.54				6420	655	2.54	5 - 6130	- 8	B-102	B-118	B-137
			3360	343	1.03				3190	325	1.03	5 - 6110SK	- 8 *3	B-99	-	B-134
			3360	343	1.25				3190	325	1.25	5 - 6115SK	- 8 *3	B-99	-	B-134
132	255	26.0	5780	589	1.06	159	211	21.5	5460	557	1.06	5 - 6115	- 11	B-101	B-117	B-136
			6580	670	1.37				6200	632	1.37	5 - 6120	- 11	B-101	B-117	B-136
			6580	670	1.60				6200	632	1.60	5 - 6125	- 11	B-101	B-117	B-136
			7770	792	2.54				7320	746	2.54	5 - 6130	- 11	B-102	B-118	B-137
112	301	30.7	5960	608	1.05	135	249	25.4	5640	574	1.05	5 - 6115	- 13	B-101	B-117	B-136
			6780	691	1.37				6400	652	1.37	5 - 6120	- 13	B-101	B-117	B-136
			6780	691	1.60				6400	652	1.60	5 - 6125	- 13	B-101	B-117	B-136
			8080	824	2.54				7620	776	2.54	5 - 6130	- 13	B-102	B-118	B-137
96.7	347	35.4	8080	824	2.76	117	288	29.3	7620	776	3.05	5 - 6135	- 13	B-102	B-118	B-137
			6330	646	1.05				5990	611	1.05	5 - 6115	- 15	B-101	B-117	B-136
			7260	741	1.37				6860	699	1.37	5 - 6120	- 15	B-101	B-117	B-136
			7260	741	1.60				6860	699	1.60	5 - 6125	- 15	B-101	B-117	B-136
85.3	394	40.1	8250	841	2.10	103	326	33.2	7770	792	2.10	5 - 6130	- 15	B-102	B-118	B-137
			8250	841	2.42				7770	792	2.42	5 - 6135	- 15	B-102	B-118	B-137
			6380	650	1.05				6040	616	1.05	5 - 6115	- 17	B-101	B-117	B-136
			7320	747	1.32				6920	705	1.37	5 - 6120	- 17	B-101	B-117	B-136
			7320	747	1.53				6920	705	1.53	5 - 6125	- 17	B-101	B-117	B-136
69.0	486	49.6	8850	902	1.96	83.3	403	41.1	8340	850	1.96	5 - 6130	- 17	B-102	B-118	B-137
			8850	902	2.24				8340	850	2.24	5 - 6135	- 17	B-102	B-118	B-137
			13100	1330	2.73				12300	1260	2.73	5 - 6140	- 17	B-102	B-118	B-137
			5010	511	0.84				6350	647	0.84	5 - 6115	- 21	B-101	B-117	B-136
			8010	816	1.07				7570	772	1.07	5 - 6120	- 21	B-101	B-117	B-136
			8010	816	1.29				7570	772	1.32	5 - 6125	- 21	B-101	B-117	B-136
83.3	403	41.1	9440	962	1.61	83.3	403	41.1	8900	908	1.66	5 - 6130	- 21	B-102	B-118	B-137
			9440	962	1.82				8900	908	2.04	5 - 6135	- 21	B-102	B-118	B-137
			14000	1420	2.34				13200	1350	2.34	5 - 6140	- 21	B-102	B-118	B-137
			14000	1420	2.56				13200	1350	2.97	5 - 6145	- 21	B-102	B-118	B-137

GEARMOTORS
Selection Tables
3.7 kW

- "*2" indicate models manufactured with reducer and motor separately mounted on a common baseplate (horizontal shaft direction) or on an adaptor (vertical shaft direction). Consult us for details, including dimensions.
- Allowable radial load (Pro) is the value at the midpoint of the slow speed shaft.
- "*3" indicate models with reduction ratios equal to nominal ratio. Refer to Table A-3 "6000 SK Series (Actual Reduction Ratio)" on page A-4 for actual reduction ratio. Indicated reduction ratio is the same as actual reduction ratio for other models.
- Maintain torque load during operation within "Output torque" in the table for models with "*" in the SF column. They cannot be operated with 100% motor rating.

Selection Tables Gearmotors

3.7 kW		n ₁ : Motor Speed							
		Hz		50Hz		60Hz			
		P		4	6	4	6		
n ₁ r/min		1450		980		1750		1165	

50Hz					60Hz					Nomenclature			Page of Dimension Sheet					
Output Speed n ₂ r/min	Output Torque Tout N·m	kgf·m	Allowable Radial Load Pro N	SF	Output Speed n ₂ r/min	Output Torque Tout N·m	kgf·m	Allowable Radial Load Pro N	SF	Input Capacity Symbol	Frame Size	Reduction Ratio	CNHM	CNFM	CNVM			
58.0	579	59.0	8350	851	1.07	70.0	480	48.9	7900	806	1.07	5 -	6125	-	25	B-101	B-117	B-136
			9790	998	1.35				9240	942	1.39	5 -	6130	-	25	B-102	B-118	B-137
			9790	998	1.55				9240	942	1.61	5 -	6135	-	25	B-102	B-118	B-137
			14600	1490	1.86				13800	1410	1.86	5 -	6140	-	25	B-102	B-118	B-137
			14600	1490	2.14				13800	1410	2.14	5 -	6145	-	25	B-102	B-118	B-137
50.0	671	68.4	8640	880	0.94	60.3	556	56.7	8180	834	1.02	5 -	6125	-	29	B-101	B-117	B-136
			10300	1050	1.16				9700	989	1.21	5 -	6130	-	29	B-102	B-118	B-137
			10300	1050	1.32				9700	989	1.52	5 -	6135	-	29	B-102	B-118	B-137
			14900	1520	1.61				14200	1440	1.61	5 -	6140	-	29	B-102	B-118	B-137
			14900	1520	2.04				14200	1440	2.04	5 -	6145	-	29	B-102	B-118	B-137
41.4	810	82.6	10800	1100	1.11	50.0	671	68.4	10200	1040	1.15	5 -	6135	-	35	B-102	B-118	B-137
			16000	1630	1.41				15100	1540	1.41	5 -	6140	-	35	B-102	B-118	B-137
			16000	1630	1.69				15100	1540	2.04	5 -	6145	-	35	B-102	B-118	B-137
			19100	1940	2.16				17900	1830	2.61	5 -	6160	-	35	B-103	B-119	B-138
			19100	1940	2.59				17900	1830	3.08	5 -	6165	-	35	B-103	B-119	B-138
33.7	995	101	11500	1170	0.91	40.7	825	84.1	10900	1110	1.02	5 -	6135	-	43	B-102	B-118	B-137
			16000	1630	1.06				15800	1610	1.06	5 -	6140	-	43	B-102	B-118	B-137
			16000	1630	1.26				15800	1610	1.46	5 -	6145	-	43	B-102	B-118	B-137
			20300	2070	1.74				19200	1950	2.01	5 -	6160	-	43	B-103	B-119	B-138
			20300	2070	2.11				19200	1950	2.14	5 -	6165	-	43	B-103	B-119	B-138
28.4	1180	120	16000	1630	1.00	34.3	978	99.7	16000	1630	1.14	5 -	6145	-	51	B-102	B-118	B-137
			21100	2150	1.49				19900	2030	1.55	5 -	6160	-	51	B-103	B-119	B-138
			21100	2150	1.78				19900	2030	2.04	5 -	6165	-	51	B-103	B-119	B-138
			24000	2440	2.07				22600	2300	2.27	5 -	6170	-	51	B-103	B-119	B-138
			24000	2440	2.67				22600	2300	3.05	5 -	6175	-	51	B-103	B-119	B-138
24.6	1370	139	16000	1630	0.86	29.7	1130	115	16000	1630	0.98	5 -	6145	-	59	B-102	B-118	B-137
			22100	2250	1.19				22100	2250	1.19	5 -	6160	-	59	B-103	B-119	B-138
			22100	2250	1.54				22100	2250	1.55	5 -	6165	-	59	B-103	B-119	B-138
			25100	2560	1.79				23700	2410	1.93	5 -	6170	-	59	B-103	B-119	B-138
			25100	2560	2.24				23700	2410	2.24	5 -	6175	-	59	B-103	B-119	B-138
20.4	1640	168	33600	3430	2.64	24.6	1360	139	31600	3220	2.64	5 -	6180	-	59	B-104	B-120	B-139
			22100	2250	1.28				21900	2240	1.53	5 -	6165	-	71	B-103	B-119	B-138
			26500	2710	1.49				25000	2550	1.60	5 -	6170	-	71	B-103	B-119	B-138
			26500	2710	1.89				25000	2550	1.93	5 -	6175	-	71	B-103	B-119	B-138
			35700	3640	2.38				33600	3430	2.38	5 -	6180	-	71	B-104	B-120	B-139
16.7	2010	205	35700	3640	2.65	20.1	1670	170	33600	3430	2.65	5 -	6185	-	71	B-104	B-120	B-139
			21800	2230	1.02				21800	2220	1.05	5 -	6165	-	87	B-103	B-119	B-138
			28400	2890	1.24				26800	2730	1.30	5 -	6170	-	87	B-103	B-119	B-138
			28400	2890	1.52				26800	2730	1.52	5 -	6175	-	87	B-103	B-119	B-138
			38400	3920	1.93				36200	3690	1.93	5 -	6180	-	87	B-104	B-120	B-139
13.9	2280	233	38400	3920	2.32	16.8	1890	193	36200	3690	2.32	5 -	6185	-	87	B-104	B-120	B-139
			1760	179	22100				2250	*1	5 -	6160DC	-	104	B-111	B-127	B-146	
			22100	2250	0.92				22100	2250	1.11	5 -	6165DC	-	104	B-111	B-127	B-146
			29500	3010	1.11				29000	2960	1.34	5 -	6170DC	-	104	B-111	B-127	B-146
			29500	3010	1.38				29000	2960	1.67	5 -	6175DC	-	104	B-111	B-127	B-146
			40900	4170	1.78				38500	3930	2.15	5 -	6180DB	-	104	B-111	B-127	B-146
			40900	4170	2.15				38500	3930	2.59	5 -	6185DB	-	104	B-111	B-127	B-146
57200	5830	2.80	53800	5490	3.22	5 -	6190DB	-	104	B-112	B-128	B-147						

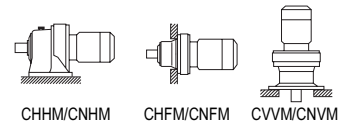

GEARMOTORS
Selection Tables
3.7 kW

1. Combinations in **bold** are the recommended models for operations for 10 hours/day with uniform load (service factor is about 1.0 for motor rating at 50Hz).
2. Motor slippage may affect n₁ and n₂. Refer to technical data for details.
3. CNHM, CHHM, CNFM, CHFM, CNVM, and CVVM indicate types. Refer to page B-10 for details.
4. Lubrication method is different for each model. Refer to "Lubrication" section in page F-4~F-5 for details.
5. "6" at the end of "input capacity symbol" indicates models with 6P motor. Other models come with 4P motor.

Selection Tables Gearmotors

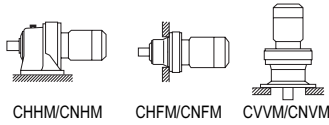

3.7 kW	Hz		50Hz		60Hz	
	P		4	6	4	6
	n ₁	r/min	1450	980	1750	1165

50Hz						60Hz					Nomenclature			Page of Dimension Sheet			
Output Speed n ₂ r/min	Output Torque Tout		Allowable Radial Load Pro		SF	Output Speed n ₂ r/min	Output Torque Tout		Allowable Radial Load Pro		SF	Input Capacity - Symbol	Frame Size -	Reduction Ratio	CNHM	CNFM	CNVM
	N·m	kgf·m	N	kgf			N·m	kgf·m	N	kgf							
12.0	2100	214	22100	2250	*1	14.5	2100	214	22100	2250	*1	5 - 6165DC	- 121	B-111	B-127	B-146	
			29500	3010	1.19				29500	3010	1.43	5 - 6175DC	- 121	B-111	B-127	B-146	
	41700	4250	1.53	41000	4180		1.85	5 - 6180DB	- 121	B-111	B-127	B-146					
	41700	4250	1.81	41000	4180		2.19	5 - 6185DB	- 121	B-111	B-127	B-146					
	2650	271	59000	6010	2.40		57300	5840	2.90	5 - 6190DB	- 121	B-112	B-128	B-147			
59000			6010	2.86	57300	5840	3.22	5 - 6195DB	- 121	B-112	B-128	B-147					
2530			258	29500	3010	*1	2530	258	29500	3010	*1	5 - 6170DC	- 143	B-111	B-127	B-146	
10.1	3140	320	29500	3010	*1	12.2	2600	265	29500	3010	1.21	5 - 6175DC	- 143	B-111	B-127	B-146	
			41700	4250	1.29				41700	4250	1.56	5 - 6180DB	- 143	B-111	B-127	B-146	
	41700	4250	1.56	41700	4250		1.89	5 - 6185DB	- 143	B-111	B-127	B-146					
	59000	6010	1.69	59000	6010		1.69	5 - 6190DA	- 143	B-111	B-128	B-147					
	59000	6010	2.03	59000	6010		2.46	5 - 6190DB	- 143	B-112	B-128	B-147					
59000	6010	2.43	59000	6010	2.94	5 - 6195DB	- 143	B-112	B-128	B-147							
8.79	3620	369	29500	3010	*1	10.6	3000	306	29500	3010	*1	5 - 6170DC	- 165	B-111	B-127	B-146	
			29500	3010	0.87				29500	3010	1.05	5 - 6175DC	- 165	B-111	B-127	B-146	
	41700	4250	1.12	41700	4250		1.35	5 - 6180DB	- 165	B-111	B-127	B-146					
	41700	4250	1.36	41700	4250		1.64	5 - 6185DB	- 165	B-111	B-127	B-146					
	59000	6010	1.69	59000	6010		1.69	5 - 6190DA	- 165	B-111	B-128	B-147					
59000	6010	1.76	59000	6010	2.13	5 - 6190DB	- 165	B-112	B-128	B-147							
59000	6010	2.19	59000	6010	2.64	5 - 6195DB	- 165	B-112	B-128	B-147							
84100	8570	2.56	84100	8570	3.09	5 - 6205DB	- 165	B-112	B-129	B-148							
7.44	4280	436	29500	3010	*1	8.97	3540	361	29500	3010	*1	5 - 6175DC	- 195	B-111	B-127	B-146	
			41700	4250	1.15				41700	4250	1.39	5 - 6185DB	- 195	B-111	B-127	B-146	
	59000	6010	1.49	59000	6010		1.69	5 - 6190DA	- 195	B-111	B-128	B-147					
	59000	6010	1.49	59000	6010		1.80	5 - 6190DB	- 195	B-112	B-128	B-147					
	59000	6010	1.52	59000	6010		1.69	5 - 6195DA	- 195	B-111	B-128	B-147					
	59000	6010	1.85	59000	6010		2.23	5 - 6195DB	- 195	B-112	B-128	B-147					
	84100	8570	2.17	84100	8570		2.62	5 - 6205DB	- 195	B-112	B-129	B-148					
	104000	10600	2.85	104000	10600		3.22	5 - 6215DA	- 195	B-112	B-129	B-148					
104000	10600	2.85	104000	10600	3.43	5 - 6215DB	- 195	B-113	B-130	B-149							
131000	13400	2.92	124000	12600	3.22	5 - 6225DA	- 195	B-113	B-130	B-149							
6.28	5070	516	41700	4250	*1	7.58	4200	428	41700	4250	*1	5 - 6180DB	- 231	B-111	B-127	B-146	
			41700	4250	0.98				41700	4250	1.19	5 - 6185DB	- 231	B-111	B-127	B-146	
	59000	6010	1.26	59000	6010		1.52	5 - 6190DA	- 231	B-111	B-128	B-147					
	59000	6010	1.57	59000	6010		1.69	5 - 6195DA	- 231	B-111	B-128	B-147					
	59000	6010	1.57	59000	6010		1.90	5 - 6195DB	- 231	B-112	B-128	B-147					
	84100	8570	1.83	84100	8570		2.21	5 - 6205DB	- 231	B-112	B-129	B-148					
	104000	10600	2.47	104000	10600		2.98	5 - 6215DA	- 231	B-112	B-129	B-148					
140000	14200	2.92	132000	13500	3.22	5 - 6225DA	- 231	B-113	B-130	B-149							
140000	14200	2.92	132000	13500	3.53	5 - 6225DB	- 231	B-113	B-130	B-149							

GEARMOTORS
Selection Tables
3.7 kW

- "*2" indicate models manufactured with reducer and motor separately mounted on a common baseplate (horizontal shaft direction) or on an adaptor (vertical shaft direction). Consult us for details, including dimensions.
- Allowable radial load (Pro) is the value at the midpoint of the slow speed shaft.
- "*3" indicate models with reduction ratios equal to nominal ratio. Refer to Table A-3 "6000SK Series (Actual Reduction Ratio)" on page A-4 for actual reduction ratio. Indicated reduction ratio is the same as actual reduction ratio for other models.
- Maintain torque load during operation within "Output torque" in the table for models with "*" in the SF column. They cannot be operated with 100% motor rating.

Selection Tables Gearmotors

3.7 kW	Hz		50Hz		60Hz	
	P		4	6	4	6
	n ₁	r/min	1450	980	1750	1165

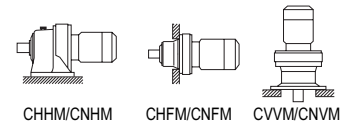

50Hz					60Hz					Nomenclature			Page of Dimension Sheet							
Output Speed n ₂ r/min	Output Torque T _{out}		Allowable Radial Load Pro		SF	Output Speed n ₂ r/min	Output Torque T _{out}		Allowable Radial Load Pro		Input Capacity Symbol	Frame Size	Reduction Ratio	CNHM	CNFM	CNVM				
	N·m	kgf·m	N	kgf			N·m	kgf·m	N	kgf										
5.31	4050	413	41700	4250	*1	6.41	4960	506	41700	4250	1.01	5 - 6180DB	- 273	B-111	B-127	B-146				
			41700	4250	0.84				41700	4250	1.01	5 - 6185DB	- 273	B-111	B-127	B-146				
			59000	6010	1.07				59000	6010	1.29	5 - 6190DA	- 273	B-111	B-128	B-147				
			59000	6010	1.33				59000	6010	1.60	5 - 6195DA	- 273	B-111	B-128	B-147				
			84100	8570	1.40				84100	8570	1.58	5 - 6205DA	- 273	B-112	B-129	B-148				
			84100	8570	1.55				84100	8570	1.87	5 - 6205DB	- 273	B-112	B-129	B-148				
			104000	10600	2.09				104000	10600	2.52	5 - 6215DA	- 273	B-112	B-129	B-148				
145000	14800	2.47	145000	14800	2.98	5 - 6225DA	- 273	B-113	B-130	B-149										
4.55	5000	510	41700	4250	*1	5.49	5800	591	41700	4250	*1	5 - 6185DB	- 319	B-111	B-127	B-146				
			59000	6010	1.14				59000	6010	1.37	5 - 6195DA	- 319	B-111	B-128	B-147				
			84100	8570	1.15				84100	8570	1.31	5 - 6205DA	- 319	B-112	B-129	B-148				
			84100	8570	1.32				84100	8570	1.59	5 - 6205DB	- 319	B-112	B-129	B-148				
			104000	10600	1.81				104000	10600	2.18	5 - 6215DA	- 319	B-112	B-129	B-148				
			145000	14800	2.15				144000	14700	2.59	5 - 6225DA	- 319	B-113	B-130	B-149				
			179000	18200	2.70				179000	18200	3.26	5 - 6235DA	- 319	B-114	B-131	B-150				
3.85	6380	650	59000	6010	*1	4.64	6850	698	59000	6010	*1	5 - 6190DA	- 377	B-111	B-128	B-147				
			58900	6010	0.96				59000	6010	1.16	5 - 6195DA	- 377	B-111	B-128	B-147				
			84100	8570	1.03				84100	8570	1.17	5 - 6205DA	- 377	B-112	B-129	B-148				
			84100	8570	1.12				84100	8570	1.35	5 - 6205DB	- 377	B-112	B-129	B-148				
			104000	10600	1.53				104000	10600	1.85	5 - 6215DA	- 377	B-112	B-129	B-148				
			145000	14800	1.82				145000	14800	2.20	5 - 6225DA	- 377	B-113	B-130	B-149				
			179000	18200	2.29				179000	18200	2.76	5 - 6235DA	- 377	B-114	B-131	B-150				
3.07	7960	811	59000	6010	*1	3.70	8600	876	59000	6010	*1	5 - 6195DA	- 473	B-111	B-128	B-147				
			8280	844	84100				8570	*1	7780	793	84100	8570	*1	5 - 6205DA	- 473	B-112	B-129	B-148
			84100	8570	0.80				84100	8570	0.90	5 - 6205DA	- 473	B-112	B-129	B-148				
			84100	8570	0.90				84100	8570	1.08	5 - 6205DB	- 473	B-112	B-129	B-148				
			10400	1060	1.22				10400	1060	1.47	5 - 6215DA	- 473	B-112	B-129	B-148				
			145000	14800	1.54				145000	14800	1.86	5 - 6225DA	- 473	B-113	B-130	B-149				
			179000	18200	1.98				179000	18200	2.38	5 - 6235DA	- 473	B-114	B-131	B-150				
208000	21200	2.49	208000	21200	3.00	5 - 6245DA	- 473	B-114	B-131	B-150										
2.59	12300	1250	104000	10600	1.03	3.13	10200	1040	104000	10600	1.25	5 - 6215DA	- 559	B-112	B-129	B-148				
			145000	14800	1.31				145000	14800	1.58	5 - 6225DA	- 559	B-113	B-130	B-149				
			179000	18200	1.67				179000	18200	2.02	5 - 6235DA	- 559	B-114	B-131	B-150				
			208000	21200	2.10				208000	21200	2.54	5 - 6245DA	- 559	B-114	B-131	B-150				
			258000	26300	2.81				258000	26300	3.40	5 - 6255DA	- 559	B-115	B-132	B-151				
			104000	10600	0.89				104000	10600	1.07	5 - 6215DA	- 649	B-112	B-129	B-148				
			145000	14800	1.12				145000	14800	1.35	5 - 6225DA	- 649	B-113	B-130	B-149				
2.23	14200	1450	179000	18200	1.44	2.70	11800	1200	179000	18200	1.74	5 - 6235DA	- 649	B-114	B-131	B-150				
			208000	21200	1.81				208000	21200	2.19	5 - 6245DA	- 649	B-114	B-131	B-150				
			258000	26300	2.42				258000	26300	2.93	5 - 6255DA	- 649	B-115	B-132	B-151				
			104000	10600	0.89				104000	10600	1.07	5 - 6215DA	- 649	B-112	B-129	B-148				
			145000	14800	1.12				145000	14800	1.35	5 - 6225DA	- 649	B-113	B-130	B-149				
			179000	18200	1.44				179000	18200	1.74	5 - 6235DA	- 649	B-114	B-131	B-150				
			208000	21200	1.81				208000	21200	2.19	5 - 6245DA	- 649	B-114	B-131	B-150				
1.98	12700	1290	104000	10600	*1	2.39	12700	1290	104000	10600	*1	5 - 6215DA	- 731	B-112	B-129	B-148				
			145000	14800	1.00				145000	14800	1.20	5 - 6225DA	- 731	B-113	B-130	B-149				
			179000	18200	1.28				179000	18200	1.54	5 - 6235DA	- 731	B-114	B-131	B-150				
			208000	21200	1.61				208000	21200	1.94	5 - 6245DA	- 731	B-114	B-131	B-150				
			258000	26300	2.15				258000	26300	2.60	5 - 6255DA	- 731	B-115	B-132	B-151				
			12700	1290	104000				10600	*1	12700	1290	104000	10600	*1	5 - 6215DA	- 841	B-112	B-129	B-148
			15000	1530	145000				14800	*1	15000	1530	145000	14800	*1	5 - 6225DA	- 841	B-113	B-130	B-149
1.72	18400	1880	145000	14800	0.82	2.08	15300	1560	145000	14800	0.98	5 - 6225DA	- 841	B-113	B-130	B-149				
			179000	18200	1.02				179000	18200	1.24	5 - 6235DA	- 841	B-114	B-131	B-150				
			208000	21200	1.40				208000	21200	1.69	5 - 6245DA	- 841	B-114	B-131	B-150				
			258000	26300	1.76				258000	26300	2.13	5 - 6255DA	- 841	B-115	B-132	B-151				
			12700	1290	104000				10600	*1	12700	1290	104000	10600	*1	5 - 6215DA	- 841	B-112	B-129	B-148
			15000	1530	145000				14800	*1	15000	1530	145000	14800	*1	5 - 6225DA	- 841	B-113	B-130	B-149
			145000	14800	0.82				145000	14800	0.98	5 - 6225DA	- 841	B-113	B-130	B-149				
1.45	15900	1620	145000	14800	*1	1.74	15900	1620	145000	14800	*1	5 - 6225DA	- 1003	B-113	B-130	B-149				
			179000	18200	0.93				179000	18200	1.12	5 - 6235DA	- 1003	B-114	B-131	B-150				
			22000	2240	208000				21200	1.17	18200	1860	208000	21200	1.42	5 - 6245DA	- 1003	B-114	B-131	B-150
			258000	26300	1.57				258000	26300	1.89	5 - 6255DA	- 1003	B-115	B-132	B-151				
			12700	1290	104000				10600	*1	12700	1290	104000	10600	*1	5 - 6215DA	- 841	B-112	B-129	B-148
			15000	1530	145000				14800	*1	15000	1530	145000	14800	*1	5 - 6225DA	- 841	B-113	B-130	B-149
			145000	14800	0.82				145000	14800	0.98	5 - 6225DA	- 841	B-113	B-130	B-149				

1. Combinations in **bold** are the recommended models for operations for 10 hours/day with uniform load (service factor is about 1.0 for motor rating at 50Hz).
2. Motor slippage may affect n₁ and n₂. Refer to technical data for details.
3. CNHM, CHHM, CNFM, CHFM, CNVM, and CVVM indicate types. Refer to page B-10 for details.
4. Lubrication method is different for each model. Refer to "Lubrication" section in page F-4~F-5 for details.
5. "6" at the end of "input capacity symbol" indicates models with 6P motor. Other models come with 4P motor.

Selection Tables Gearmotors

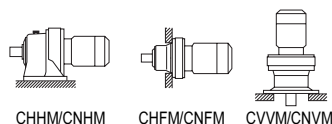

3.7 kW	Hz		50Hz		60Hz	
	P		4	6	4	6
	n ₁	r/min	1450	980	1750	1165

50Hz						60Hz						Nomenclature			Page of Dimension Sheet		
Output Speed n ₂ r/min	Output Torque Tout		Allowable Radial Load Pro		SF	Output Speed n ₂ r/min	Output Torque Tout		Allowable Radial Load Pro		SF	Input Capacity Symbol	Frame Size	Reduction Ratio	CNHM	CNFM	CNVM
	N·m	kgf·m	N	kgf			N·m	kgf·m	N	kgf							
1.16	20500	2090	179000	18200	*1	1.40	20500	2090	179000	18200	*1	5 -	6235DA	-1247	B-114	B-131	B-150
	27300	2790	208000	21200	0.94		22700	2310	208000	21200	1.14	5 -	6245DA	-1247	B-114	B-131	B-150
0.980	22600	2310	208000	21200	*1	1.18	22600	2310	208000	21200	*1	5 -	6245DA	-1479	B-114	B-131	B-150
	32400	3310	258000	26300	0.96		26900	2740	258000	26300	1.15	5 -	6255DA	-1479	B-115	B-132	B-151
0.784	40600	4130	258000	26300	0.85	0.946	33600	3430	258000	26300	1.03	5 -	6255DA	-1849	B-115	B-132	B-151
0.702	34500	3520	258000	26300	*1	0.847	34500	3520	258000	26300	*1	5 -	6255DA	-2065	B-115	B-132	B-151
0.572	34500	3520	258000	26300	*1	0.690	34500	3520	258000	26300	*1	5 -	6255DA	-2537	B-115	B-132	B-151
0.476	31000	3160	258000	26300	*1	0.575	31000	3160	258000	26300	*1	5 -	6255DA	-3045	B-115	B-132	B-151
0.417	34500	3520	258000	26300	*1	0.503	34500	3520	258000	26300	*1	5 -	6255DA	-3481	B-115	B-132	B-151
0.327	31000	3160	258000	26300	*1	0.394	31000	3160	258000	26300	*1	5 -	6255DA	-4437	B-115	B-132	B-151
0.282	34500	3520	258000	26300	*1	0.341	34500	3520	258000	26300	*1	5 -	6255DA	-5133	B-115	B-132	B-151
0.235	31000	3160	258000	26300	*1	0.283	31000	3160	258000	26300	*1	5 -	6255DA	-6177	B-115	B-132	B-151
0.192	31000	3160	258000	26300	*1	0.231	31000	3160	258000	26300	*1	5 -	6255DA	-7569	B-115	B-132	B-151

GEARMOTORS

Selection Tables
3.7 kW, 5.5 kW

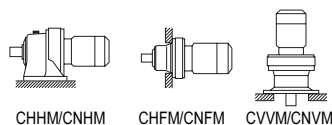

5.5 kW	Hz		50Hz		60Hz	
	P		4	6	4	6
	n ₁	r/min	1450	980	1750	1165

50Hz						60Hz						Nomenclature			Page of Dimension Sheet								
Output Speed n ₂ r/min	Output Torque Tout		Allowable Radial Load Pro		SF	Output Speed n ₂ r/min	Output Torque Tout		Allowable Radial Load Pro		SF	Input Capacity Symbol	Frame Size	Reduction Ratio	CNHM	CNFM	CNVM						
	N·m	kgf·m	N	kgf			N·m	kgf·m	N	kgf								CHHM	CHF	CVVM			
580	86.0	8.77	2410	246	1.17	700	71.3	7.27	2330	238	1.17	8 -	6115SK	- 2.5 *3	B-99	-	B-134						
483	103	10.5	2530	258	1.20	583	85.5	8.72	2450	250	1.20	8 -	6115SK	- 3 *3	B-99	-	B-134						
363	138	14.0	2640	269	1.22	11.6	2580	263	2580	263	1.22	8 -	6115SK	- 4 *3	B-99	-	B-134						
242	172	17.5	2690	274	1.05	350	143	14.5	2640	269	1.05	8 -	6115SK	- 5 *3	B-99	-	B-134						
			2710	276	0.96				2700	275	0.96							8 -	6115SK	- 6 *3	B-99	-	B-134
			5140	524	1.27				4850	494	1.06							8 -	6125	- 6	B-101	B-117	B-136
			6060	617	1.71				5710	582	1.71							8 -	6130	- 6	B-102	B-118	B-137
			6060	617	2.05				5710	582	2.05							8 -	6135	- 6	B-102	B-118	B-137
			9370	955	2.36				8860	903	2.36							8 -	6140	- 6	B-102	B-118	B-137
181	206	21.0	9370	955	2.75	292	171	17.4	8860	903	2.75	8 -	6145	- 6	B-102	B-118	B-137						
			2680	273	0.84				2710	276	0.84							8 -	6115SK	- 8 *3	B-99	-	B-134
			5710	582	1.26				5400	550	1.26							8 -	6125	- 8	B-101	B-117	B-136
			6740	687	1.71				6360	648	1.71							8 -	6130	- 8	B-102	B-118	B-137
			6740	687	2.05				6360	648	2.05							8 -	6135	- 8	B-102	B-118	B-137
			10400	1060	2.36				9820	1000	2.36							8 -	6140	- 8	B-102	B-118	B-137
132	275	28.1	10400	1060	2.75	219	228	23.3	9820	1000	2.75	8 -	6145	- 8	B-102	B-118	B-137						
			6450	658	1.08				6100	622	1.08							8 -	6125	- 11	B-101	B-117	B-136
			7680	783	1.71				7240	739	1.71							8 -	6130	- 11	B-102	B-118	B-137
			7680	783	2.05				7240	739	2.05							8 -	6135	- 11	B-102	B-118	B-137
			11600	1190	2.36				11000	1120	2.36							8 -	6140	- 11	B-102	B-118	B-137
			11600	1190	2.75				11000	1120	2.75							8 -	6145	- 11	B-102	B-118	B-137

- "*2" indicate models manufactured with reducer and motor separately mounted on a common baseplate (horizontal shaft direction) or on an adaptor (vertical shaft direction). Consult us for details, including dimensions.
- Allowable radial load (Pro) is the value at the midpoint of the slow speed shaft.
- "*3" indicate models with reduction ratios equal to nominal ratio. Refer to Table A-3 "6000SK Series (Actual Reduction Ratio)" on page A-4 for actual reduction ratio. Indicated reduction ratio is the same as actual reduction ratio for other models.
- Maintain torque load during operation within "Output torque" in the table for models with "*"1" in the SF column. They cannot be operated with 100% motor rating.

Selection Tables Gearmotors

5.5 kW	Hz		50Hz		60Hz	
	P		4	6	4	6
	n ₁	r/min	1450	980	1750	1165

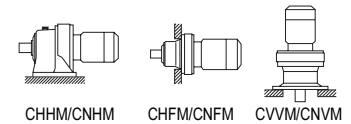

50Hz						60Hz						Nomenclature			Page of Dimension Sheet					
Output Speed n ₂ r/min	Output Torque Tout N·m kgf·m		Allowable Radial Load Pro N kgf		SF	Output Speed n ₂ r/min	Output Torque Tout N·m kgf·m		Allowable Radial Load Pro N kgf		SF	Input Capacity Symbol	Frame Size	Reduction Ratio	CNHM	CNFM	CNVM			
112	447	45.6	6630	676	1.08	135	371	37.8	6280	640	1.08	8 -	6125	- 13	B-101	B-117	B-136			
			7980	814	1.71				7530	768	1.71				8 -	6130	- 13	B-102	B-118	B-137
			7980	814	1.85				7530	768	2.05				8 -	6135	- 13	B-102	B-118	B-137
			11900	1210	2.36				11300	1150	2.36				8 -	6140	- 13	B-102	B-118	B-137
96.7	516	52.6	7100	724	1.08	117	428	43.6	6730	686	1.08	8 -	6125	- 15	B-101	B-117	B-136			
			8130	829	1.41				7680	783	1.41				8 -	6130	- 15	B-102	B-118	B-137
			8130	829	1.63				7680	783	1.63				8 -	6135	- 15	B-102	B-118	B-137
			12400	1270	2.18				11800	1200	2.18				8 -	6140	- 15	B-102	B-118	B-137
85.3	585	59.6	7150	729	1.03	103	485	49.4	6780	691	1.03	8 -	6125	- 17	B-101	B-117	B-136			
			8710	888	1.32				8230	839	1.32				8 -	6130	- 17	B-102	B-118	B-137
			8710	888	1.51				8230	839	1.51				8 -	6135	- 17	B-102	B-118	B-137
			13000	1320	1.84				12300	1250	1.84				8 -	6140	- 17	B-102	B-118	B-137
69.0	723	73.7	9260	944	1.08	83.3	599	61.0	8760	893	1.12	8 -	6130	- 21	B-102	B-118	B-137			
			9260	944	1.22				8760	893	1.37				8 -	6135	- 21	B-102	B-118	B-137
			13900	1410	1.57				13100	1340	1.57				8 -	6140	- 21	B-102	B-118	B-137
			13900	1410	1.73				13100	1340	2.00				8 -	6145	- 21	B-102	B-118	B-137
58.0	860	87.7	9580	977	1.05	70.0	713	72.7	9070	925	1.08	8 -	6135	- 25	B-102	B-118	B-137			
			14500	1480	1.25				13800	1400	1.25				8 -	6140	- 25	B-102	B-118	B-137
			14500	1480	1.44				13800	1400	1.44				8 -	6145	- 25	B-102	B-118	B-137
			17100	1740	1.79				16100	1640	1.79				8 -	6160	- 25	B-103	B-119	B-138
50.0	998	102	14800	1510	1.08	60.3	827	84.3	14100	1430	1.08	8 -	6140	- 29	B-102	B-118	B-137			
			14800	1510	1.37				14100	1430	1.37				8 -	6145	- 29	B-102	B-118	B-137
			17800	1810	1.74				16800	1710	1.91				8 -	6160	- 29	B-103	B-119	B-138
			17800	1810	2.07				16800	1710	2.07				8 -	6165	- 29	B-103	B-119	B-138
41.4	1200	123	14800	1510	1.08	50.0	998	102	14100	1430	1.08	8 -	6140	- 35	B-102	B-118	B-137			
			14800	1510	1.37				14100	1430	1.37				8 -	6145	- 35	B-102	B-118	B-137
			17800	1810	1.74				16800	1710	1.91				8 -	6160	- 35	B-103	B-119	B-138
			17800	1810	2.07				16800	1710	2.07				8 -	6165	- 35	B-103	B-119	B-138
33.7	1480	151	20000	2040	1.17	40.7	1230	125	18900	1930	1.44	8 -	6165	- 43	B-103	B-119	B-138			
			20000	2040	1.42				18900	1930	1.44				8 -	6165	- 43	B-103	B-119	B-138
			22800	2320	1.65				21500	2190	1.77				8 -	6170	- 43	B-103	B-119	B-138
			22800	2320	2.05				21500	2190	2.05				8 -	6175	- 43	B-103	B-119	B-138
28.4	1760	179	20800	2120	1.00	34.3	1450	148	19600	2000	1.05	8 -	6160	- 51	B-103	B-119	B-138			
			20800	2120	1.20				19600	2000	1.37				8 -	6165	- 51	B-103	B-119	B-138
			23700	2420	1.39				22400	2280	1.53				8 -	6170	- 51	B-103	B-119	B-138
			23700	2420	1.79				22400	2280	2.05				8 -	6175	- 51	B-103	B-119	B-138
			31900	3260	2.18				30100	3070	2.18									
			31900	3260	2.75				30100	3070	2.75									

1. Combinations in **bold** are the recommended models for operations for 10 hours/day with uniform load (service factor is about 1.0 for motor rating at 50Hz).
2. Motor slippage may affect n₁ and n₂. Refer to technical data for details.
3. CNHM, CHHM, CNFM, CHFM, CNVM, and CVVM indicate types. Refer to page B-10 for details.
4. Lubrication method is different for each model. Refer to "Lubrication" section in page F-4~F-5 for details.
5. "6" at the end of "input capacity symbol" indicates models with 6P motor. Other models come with 4P motor.

Selection Tables Gearmotors

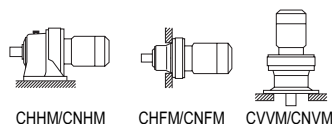

5.5 kW	Hz		50Hz		60Hz	
	P		4	6	4	6
	n ₁	r/min	1450	980	1750	1165

n₁: Motor Speed

50Hz						60Hz					Nomenclature			Page of Dimension Sheet									
Output Speed n ₂ r/min	Output Torque Tout		Allowable Radial Load Pro		SF	Output Speed n ₂ r/min	Output Torque Tout		Allowable Radial Load Pro		SF	Input Capacity - Symbol	Frame Size	Reduction Ratio	CNHM	CNFM	CNVM						
	N·m	kgf·m	N	kgf			N·m	kgf·m	N	kgf								CHHM	CHFM	CVVM			
24.6	2030	207	22100	2250	1.03	29.7	1680	171	21700	2220	1.05	8 -	6165	- 59	B-103	B-119	B-138						
			24800	2530	1.20				23400	2390	1.30							8 -	6170	- 59	B-103	B-119	B-138
			24800	2530	1.51				23400	2390	1.51							8 -	6175	- 59	B-103	B-119	B-138
			33400	3400	1.77				31400	3200	1.77							8 -	6180	- 59	B-104	B-120	B-139
			33400	3400	2.18				31400	3200	2.18							8 -	6185	- 59	B-104	B-120	B-139
			47000	4790	2.78				44200	4500	2.78							8 -	6190	- 59	B-104	B-120	B-139
20.4	2440	249	22100	2250	0.86	24.6	2020	206	21600	2200	1.03	8 -	6165	- 71	B-103	B-119	B-138						
			26200	2670	1.00				24700	2520	1.08							8 -	6170	- 71	B-103	B-119	B-138
			26200	2670	1.27				24700	2520	1.30							8 -	6175	- 71	B-103	B-119	B-138
			35500	3620	1.60				33400	3410	1.60							8 -	6180	- 71	B-104	B-120	B-139
			35500	3620	1.78				33400	3410	1.78							8 -	6185	- 71	B-104	B-120	B-139
			49800	5080	2.45				46900	4780	2.45							8 -	6190	- 71	B-104	B-120	B-139
16.7	2990	305	27900	2840	1.02	20.1	2480	253	26400	2690	1.02	8 -	6175	- 87	B-103	B-119	B-138						
			38100	3880	1.30				35900	3660	1.30							8 -	6180	- 87	B-104	B-120	B-139
			38100	3880	1.56				35900	3660	1.56							8 -	6185	- 87	B-104	B-120	B-139
			53600	5470	2.13				50500	5140	2.15							8 -	6190	- 87	B-104	B-120	B-139
			53600	5470	2.47				50500	5140	2.47							8 -	6195	- 87	B-104	B-120	B-139
			2100	214	22100				2250	*1	16.8							2810	286	2100	214	22100	2250
2530	258	29500	3010	*1	2530	258	28600	2920	*1	8 -		6170DC	- 104	B-111	B-127	B-146							
29500	3010	0.93	28500	2900	1.12	8 -	6175DC	- 104	B-111	B-127		B-146											
40500	4130	1.20	38200	3890	1.45	8 -	6180DB	- 104	B-111	B-127		B-146											
40500	4130	1.45	38200	3890	1.74	8 -	6185DB	- 104	B-111	B-127		B-146											
56800	5790	1.88	53500	5460	2.17	8 -	6190DB	- 104	B-112	B-128		B-147											
13.9	3390	346	56800	5790	2.17	14.5	3270	333	53500	5460	2.17	8 -	6195DB	- 104	B-112	B-128	B-147						
			2530	258	29500				3010	*1	2530	258	29500	3010	*1	8 -	6170DC	- 121	B-111	B-127	B-146		
			3150	321	29500				3010	*1	3150	321	29500	3010	*1	8 -	6175DC	- 121	B-111	B-127	B-146		
			29500	3010	0.80				29500	3010	0.96	8 -	6175DC	- 121	B-111	B-127	B-146						
			41700	4250	1.03				40600	4140	1.24	8 -	6180DB	- 121	B-111	B-127	B-146						
			41700	4250	1.22				40600	4140	1.47	8 -	6185DB	- 121	B-111	B-127	B-146						
10.1	4660	475	59000	6010	1.14	12.2	3860	394	57000	5810	1.95	8 -	6190DB	- 121	B-112	B-128	B-147						
			59000	6010	1.37				57000	5810	2.17	8 -	6195DB	- 121	B-112	B-128	B-147						
			59000	6010	1.64				84100	8570	2.17	8 -	6205DB	- 121	B-112	B-129	B-148						
			59000	6010	1.64				103000	10500	3.48	8 -	6215DB	- 121	B-113	B-130	B-149						
			3150	321	29500				3010	*1	3150	321	29500	3010	*1	8 -	6175DC	- 143	B-111	B-127	B-146		
			41700	4250	1.05				41700	4250	1.27	8 -	6185DB	- 143	B-111	B-127	B-146						
8.79	5380	548	59000	6010	1.14	10.6	4460	454	59000	6010	1.14	8 -	6190DA	- 143	B-111	B-128	B-147						
			59000	6010	1.37				59000	6010	1.65	8 -	6190DB	- 143	B-112	B-128	B-147						
			59000	6010	1.64				59000	6010	1.97	8 -	6195DB	- 143	B-112	B-128	B-147						
			3150	321	29500				3010	*1	3150	321	29500	3010	*1	8 -	6175DC	- 165	B-111	B-127	B-146		
			4060	414	41700				4250	*1	4060	414	41700	4250	*1	8 -	6180DB	- 165	B-111	B-127	B-146		
			41700	4250	0.92				41700	4250	1.10	8 -	6185DB	- 165	B-111	B-127	B-146						
10.6	5380	548	59000	6010	1.14	10.6	4460	454	59000	6010	1.14	8 -	6190DA	- 165	B-111	B-128	B-147						
			59000	6010	1.19				59000	6010	1.43	8 -	6190DB	- 165	B-112	B-128	B-147						
			59000	6010	1.47				59000	6010	1.77	8 -	6195DB	- 165	B-112	B-128	B-147						
			84100	8570	1.72				84100	8570	2.08	8 -	6205DB	- 165	B-112	B-129	B-148						
			104000	10600	2.17				104000	10600	2.17	8 -	6215DA	- 165	B-112	B-129	B-148						
			104000	10600	2.26				104000	10600	2.73	8 -	6215DB	- 165	B-113	B-130	B-149						
124000	12700	2.69	118000	12000	3.25	8 -	6225DB	- 165	B-113	B-130	B-149												

GEARMOTORS
Selection Tables
5.5 kW

- "*2" indicate models manufactured with reducer and motor separately mounted on a common baseplate (horizontal shaft direction) or on an adaptor (vertical shaft direction). Consult us for details, including dimensions.
- Allowable radial load (Pro) is the value at the midpoint of the slow speed shaft.
- "*3" indicate models with reduction ratios equal to nominal ratio. Refer to Table A-3 "6000SK Series (Actual Reduction Ratio)" on page A-4 for actual reduction ratio. Indicated reduction ratio is the same as actual reduction ratio for other models.
- Maintain torque load during operation within "Output torque" in the table for models with "*" in the SF column. They cannot be operated with 100% motor rating.

Selection Tables Gearmotors

5.5 kW	Hz		50Hz		60Hz	
	P		4	6	4	6
	n ₁	r/min	1450	980	1750	1165

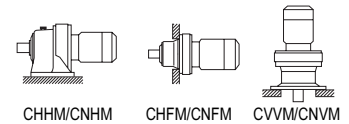

50Hz						60Hz					Nomenclature			Page of Dimension Sheet					
Output Speed n ₂	Output Torque Tout		Allowable Radial Load Pro		SF	Output Speed n ₂	Output Torque Tout		Allowable Radial Load Pro		SF	Input Capacity Symbol	Frame Size	Reduction Ratio	CNHM	CNFM	CNVM		
r/min	N·m	kgf·m	N	kgf		r/min	N·m	kgf·m	N	kgf					CHHM	CHFM	CVVM		
7.44	4060	414	41700	4250	*1	8.97	4060	414	41700	4250	*1	8 -	6180DB - 195		B-111	B-127	B-146		
	4920	502	41700	4250	*1		4920	502	41700	4250	*1	8 -	6185DB - 195		B-111	B-127	B-146		
			58900	6000	1.00					59000	6010	1.14	8 -	6190DA - 195	B-111	B-128	B-147		
			58900	6000	1.00					59000	6010	1.21	8 -	6190DB - 195		B-112	B-128	B-147	
			58900	6000	1.02					59000	6010	1.14	8 -	6195DA - 195		B-111	B-128	B-147	
			58900	6000	1.24					59000	6010	1.50	8 -	6195DB - 195		B-112	B-128	B-147	
	6360	648	84100	8570	1.46		7.58	5270	537	84100	8570	1.76	8 -	6205DB - 195		B-112	B-129	B-148	
			104000	10600	1.91						104000	10600	2.17	8 -	6215DA - 195		B-112	B-129	B-148
			104000	10600	1.91						104000	10600	2.31	8 -	6215DB - 195		B-113	B-130	B-149
			131000	13300	1.96						124000	12600	2.17	8 -	6225DA - 195		B-113	B-130	B-149
		131000	13300	2.28					124000	12600	2.75	8 -	6225DB - 195		B-113	B-130	B-149		
		5000	510	41700	4250	*1		5000	510	41700	4250	*1	8 -	6185DB - 231		B-111	B-127	B-146	
6.28			59000	6010	1.06	7.58			59000	6010	1.14	8 -	6195DA - 231	B-111	B-128	B-147			
			59000	6010	1.06				59000	6010	1.28	8 -	6195DB - 231		B-112	B-128	B-147		
			84100	8570	1.23				84100	8570	1.49	8 -	6205DB - 231		B-112	B-129	B-148		
	7530	768	104000	10600	1.66		7.58	6240	636	104000	10600	2.00	8 -	6215DA - 231		B-112	B-129	B-148	
			139000	14200	1.97						132000	13400	2.17	8 -	6225DA - 231		B-113	B-130	B-149
			139000	14200	1.97						132000	13400	2.37	8 -	6225DB - 231		B-113	B-130	B-149
			173000	17700	2.51						164000	16700	3.03	8 -	6235DA - 231		B-114	B-131	B-150
5.31	5000	510	41700	4250	*1	6.41	5000	510	41700	4250	*1	8 -	6185DB - 273		B-111	B-127	B-146		
	6380	650	59000	6010	*1		6380	650	59000	6010	*1	8 -	6190DA - 273		B-111	B-128	B-147		
			59000	6010	0.89					59000	6010	1.08	8 -	6195DA - 273		B-111	B-128	B-147	
			84100	8570	0.94					84100	8570	1.07	8 -	6205DA - 273		B-112	B-129	B-148	
			84100	8570	1.04					84100	8570	1.26	8 -	6205DB - 273	B-112	B-129	B-148		
	8900	907	104000	10600	1.40		6.41	7370	752	104000	10600	1.70	8 -	6215DA - 273		B-112	B-129	B-148	
			145000	14800	1.66						138000	14100	2.01	8 -	6225DA - 273		B-113	B-130	B-149
			179000	18200	2.12						172000	17600	2.56	8 -	6235DA - 273		B-114	B-131	B-150
		203000	20600	2.90					192000	19500	3.50	8 -	6245DA - 273		B-114	B-131	B-150		
4.55	6380	650	59000	6010	*1	5.49	6380	650	59000	6010	*1	8 -	6190DA - 319		B-111	B-128	B-147		
	7960	811	59000	6010	*1		7960	811	59000	6010	*1	8 -	6195DA - 319		B-111	B-128	B-147		
	8080	823	84100	8570	*1		7590	773	84100	8570	*1	8 -	6205DA - 319		B-112	B-129	B-148		
			84100	8570	0.89					84100	8570	1.07	8 -	6205DB - 319		B-112	B-129	B-148	
			104000	10600	1.22					104000	10600	1.47	8 -	6215DA - 319		B-112	B-129	B-148	
	10400	1060	145000	14800	1.45		5.49	8620	878	143000	14600	1.75	8 -	6225DA - 319		B-113	B-130	B-149	
			179000	18200	1.82						179000	18200	2.19	8 -	6235DA - 319		B-114	B-131	B-150
			208000	21200	2.48						200000	20400	2.99	8 -	6245DA - 319		B-114	B-131	B-150
		7960	811	59000	6010	*1		7960	811	59000	6010	*1	8 -	6195DA - 377		B-111	B-128	B-147	
3.85	8550	872	84100	8570	*1	4.64	8030	819	84100	8570	*1	8 -	6205DA - 377		B-112	B-129	B-148		
			104000	10600	1.03					104000	10600	1.24	8 -	6215DA - 377	B-112	B-129	B-148		
			145000	14800	1.22					145000	14800	1.48	8 -	6225DA - 377		B-113	B-130	B-149	
	12300	1250	179000	18200	1.54		4.64	10200	1040	179000	18200	1.86	8 -	6235DA - 377		B-114	B-131	B-150	
			208000	21200	2.10						208000	21200	2.53	8 -	6245DA - 377		B-114	B-131	B-150
			258000	26300	2.64						258000	26300	3.19	8 -	6255DA - 377		B-115	B-132	B-151

1. Combinations in **bold** are the recommended models for operations for 10 hours/day with uniform load (service factor is about 1.0 for motor rating at 50Hz).
2. Motor slippage may affect n₁ and n₂. Refer to technical data for details.
3. CNHM, CHHM, CNFM, CHFM, CNVM, and CVVM indicate types. Refer to page B-10 for details.
4. Lubrication method is different for each model. Refer to "Lubrication" section in page F-4~F-5 for details.
5. "6" at the end of "input capacity symbol" indicates models with 6P motor. Other models come with 4P motor.

Selection Tables Gearmotors

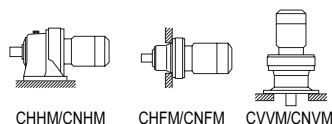

<h2>5.5 kW</h2>	Hz		50Hz		60Hz	
	P		4	6	4	6
	n ₁	r/min	1450	980	1750	1165

50Hz					60Hz					Nomenclature			Page of Dimension Sheet								
Output Speed n ₂ r/min	Output Torque T _{out}		Allowable Radial Load Pro		SF	Output Speed n ₂ r/min	Output Torque T _{out}		Allowable Radial Load Pro		Input Capacity Symbol	Frame Size	Reduction Ratio	CNHM	CNFM	CNVM					
	N·m	kgf·m	N	kgf			N·m	kgf·m	N	kgf							CHHM	CHF	CVVM		
3.07	12700	1290	104000	10600	*1	12700	1290	104000	10600	*1	8 - 6215DA	- 473	B-112	B-129	B-148						
			104000	10600	0.82			8 - 6215DA	- 473	B-112	B-129	B-148									
	15400	1570	145000	14800	1.04	12800	1300	145000	14800	1.25	8 - 6225DA	- 473	B-113	B-130	B-149						
			179000	18200	1.33			8 - 6235DA	- 473	B-114	B-131	B-150									
			208000	21200	1.67			8 - 6245DA	- 473	B-114	B-131	B-150									
			258000	26300	2.24			8 - 6255DA	- 473	B-115	B-132	B-151									
276000	28100	2.98	8 - 6265DA	- 473	B-115	B-132	B-151														
2.59	12700	1290	104000	10600	*1	12700	1290	104000	10600	*1	8 - 6215DA	- 559	B-112	B-129	B-148						
			145000	14800	0.88			8 - 6225DA	- 559	B-113	B-130	B-149									
	18200	1860	179000	18200	1.12	15100	1540	179000	18200	1.36	8 - 6235DA	- 559	B-114	B-131	B-150						
			208000	21200	1.42			8 - 6245DA	- 559	B-114	B-131	B-150									
			258000	26300	1.89			8 - 6255DA	- 559	B-115	B-132	B-151									
			276000	28100	2.52			8 - 6265DA	- 559	B-115	B-132	B-151									
2.23	12700	1290	104000	10600	*1	12700	1290	104000	10600	*1	8 - 6215DA	- 649	B-112	B-129	B-148						
			145000	14800	*1			8 - 6225DA	- 649	B-113	B-130	B-149									
	21200	2160	179000	18200	0.97	17500	1790	179000	18200	1.17	8 - 6235DA	- 649	B-114	B-131	B-150						
			208000	21200	1.22			8 - 6245DA	- 649	B-114	B-131	B-150									
			258000	26300	1.63			8 - 6255DA	- 649	B-115	B-132	B-151									
			276000	28100	2.17			8 - 6265DA	- 649	B-115	B-132	B-151									
1.98	16000	1630	145000	14800	*1	16000	1630	145000	14800	*1	8 - 6225DA	- 731	B-113	B-130	B-149						
			179000	18200	0.86			8 - 6235DA	- 731	B-114	B-131	B-150									
	23800	2430	208000	21200	1.08	19700	2010	208000	21200	1.31	8 - 6245DA	- 731	B-114	B-131	B-150						
			258000	26300	1.45			8 - 6255DA	- 731	B-115	B-132	B-151									
			276000	28100	1.93			8 - 6265DA	- 731	B-115	B-132	B-151									
			18900	1930	179000			18200	*1	18900	1930	179000	18200	*1	8 - 6235DA	- 841	B-114	B-131	B-150		
208000	21200	0.94	8 - 6245DA	- 841	B-114	B-131	B-150														
1.72	27400	2790	258000	26300	1.18	22700	2320	258000	26300	1.43	8 - 6255DA	- 841	B-115	B-132	B-151						
			276000	28100	1.68			8 - 6265DA	- 841	B-115	B-132	B-151									
			20500	2090	179000			18200	*1	1740	27600	20500	2090	179000	18200	*1	8 - 6235DA	- 1003	B-114	B-131	B-150
			25800	2630	208000			21200	*1			25800	2630	208000	21200	*1	8 - 6245DA	- 1003	B-114	B-131	B-150
1.45	32700	3330	258000	26300	1.06	27100	2760	258000	26300	1.27	8 - 6255DA	- 1003	B-115	B-132	B-151						
			276000	28100	1.41			8 - 6265DA	- 1003	B-115	B-132	B-151									
1.16	25800	2630	208000	21200	*1	1400	33700	25800	26300	*1	8 - 6245DA	- 1247	B-114	B-131	B-150						
			258000	26300	0.85			8 - 6255DA	- 1247	B-115	B-132	B-151									
			276000	28100	1.13			8 - 6265DA	- 1247	B-115	B-132	B-151									
0.980	31000	3160	258000	26300	*1	1180	40000	31000	3160	258000	26300	*1	8 - 6255DA	- 1479	B-115	B-132	B-151				
			48200	4920	276000			28100	0.91	40000	4070	276000	28100	1.10	8 - 6265DA	- 1479	B-115	B-132	B-151		
0.784	34500	3520	258000	26300	*1	0.946	46000	34500	3520	258000	26300	*1	8 - 6255DA	- 1849	B-115	B-132	B-151				
			46000	4690	276000			28100	*1	46000	4690	276000	28100	*1	8 - 6265DA	- 1849	B-115	B-132	B-151		
0.702	46000	4690	276000	28100	*1	0.847	46000	4690	276000	28100	*1	8 - 6265DA	- 2065	B-115	B-132	B-151					
0.572	46000	4690	276000	28100	*1	0.690	46000	4690	276000	28100	*1	8 - 6265DA	- 2537	B-115	B-132	B-151					
0.476	44000	4490	276000	28100	*1	0.575	44000	4490	276000	28100	*1	8 - 6265DA	- 3045	B-115	B-132	B-151					
0.417	46000	4690	276000	28100	*1	0.503	46000	4690	276000	28100	*1	8 - 6265DA	- 3481	B-115	B-132	B-151					
0.327	44000	4490	276000	28100	*1	0.394	44000	4490	276000	28100	*1	8 - 6265DA	- 4437	B-115	B-132	B-151					
0.282	46000	4690	276000	28100	*1	0.341	46000	4690	276000	28100	*1	8 - 6265DA	- 5133	B-115	B-132	B-151					
0.235	44000	4490	276000	28100	*1	0.283	44000	4490	276000	28100	*1	8 - 6265DA	- 6177	B-115	B-132	B-151					
0.192	44000	4490	276000	28100	*1	0.231	44000	4490	276000	28100	*1	8 - 6265DA	- 7569	B-115	B-132	B-151					

GEARMOTORS
Selection Tables
5.5 kW

- "*2" indicate models manufactured with reducer and motor separately mounted on a common baseplate (horizontal shaft direction) or on an adaptor (vertical shaft direction). Consult us for details, including dimensions.
- Allowable radial load (Pro) is the value at the midpoint of the slow speed shaft.
- "*3" indicate models with reduction ratios equal to nominal ratio. Refer to Table A-3 "6000SK Series (Actual Reduction Ratio)" on page A-4 for actual reduction ratio. Indicated reduction ratio is the same as actual reduction ratio for other models.
- Maintain torque load during operation within "Output torque" in the table for models with "*" in the SF column. They cannot be operated with 100% motor rating.

Selection Tables Gearmotors

7.5 kW	Hz		50Hz		60Hz	
	P		4	6	4	6
	n ₁	r/min	1450	980	1750	1165

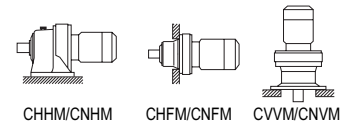

50Hz					60Hz					Nomenclature			Page of Dimension Sheet				
Output Speed n ₂ r/min	Output Torque T _{out} N·m	kgf·m	Allowable Radial Load Pro N	SF	Output Speed n ₂ r/min	Output Torque T _{out} N·m	kgf·m	Allowable Radial Load Pro N	SF	Input Capacity Symbol	Frame Size	Reduction Ratio	CNHM CHHM	CNFM CHFM	CNVM CVVM		
242	282	28.7	5980	1.25	292	233	23.8	5650	1.25	10 -	6130	- 6	B-102	B-118	B-137		
			5980	1.51				5650	1.51				6135	6	B-102	B-118	B-137
			9330	1.73				8830	1.73				6140	6	B-102	B-118	B-137
			9330	2.01				8830	2.01				6145	6	B-102	B-118	B-137
			10400	2.71				9830	2.71				6160	6	B-103	B-119	B-138
181	375	38.3	6650	1.25	219	311	31.7	6290	1.25	10 -	6130	- 8	B-102	B-118	B-137		
			6650	1.51				6290	1.51				6135	8	B-102	B-118	B-137
			10300	1.73				9790	1.73				6140	8	B-102	B-118	B-137
			10300	2.01				9790	2.01				6145	8	B-102	B-118	B-137
			11700	2.63				11000	2.63				6160	8	B-103	B-119	B-138
132	516	52.6	7570	1.25	159	428	43.6	7150	1.25	10 -	6130	- 11	B-102	B-118	B-137		
			7570	1.51				7150	1.51				6135	11	B-102	B-118	B-137
			11600	1.73				11000	1.73				6140	11	B-102	B-118	B-137
			11600	2.01				11000	2.01				6145	11	B-102	B-118	B-137
			13200	2.63				12500	2.63				6160	11	B-103	B-119	B-138
112	610	62.2	7860	1.25	135	505	51.5	7430	1.25	10 -	6130	- 13	B-102	B-118	B-137		
			7860	1.36				7430	1.51				6135	13	B-102	B-118	B-137
			11800	1.73				11200	1.73				6140	13	B-102	B-118	B-137
			11800	2.01				11200	2.01				6145	13	B-102	B-118	B-137
			13800	2.63				13000	2.63				6160	13	B-103	B-119	B-138
96.7	704	71.8	8000	1.04	117	583	59.5	7570	1.04	10 -	6130	- 15	B-102	B-118	B-137		
			8000	1.20				7570	1.20				6135	15	B-102	B-118	B-137
			12400	1.60				11700	1.60				6140	15	B-102	B-118	B-137
			12400	1.93				11700	2.01				6145	15	B-102	B-118	B-137
			14700	2.49				13800	2.49				6160	15	B-103	B-119	B-138
85.3	798	81.3	8550	1.11	103	661	67.4	8100	1.11	10 -	6135	- 17	B-102	B-118	B-137		
			12900	1.35				12200	1.35				6140	17	B-102	B-118	B-137
			12900	1.60				12200	1.60				6145	17	B-102	B-118	B-137
			15100	1.75				14300	1.75				6160	17	B-103	B-119	B-138
			15100	2.51				14300	2.51				6165	17	B-103	B-119	B-138
69.0	985	100	13800	1.15	83.3	817	83.2	13100	1.15	10 -	6140	- 21	B-102	B-118	B-137		
			9050	0.90				8590	1.00				6135	21	B-102	B-118	B-137
			13800	1.27				13100	1.47				6145	21	B-102	B-118	B-137
			16200	1.72				15300	1.72				6160	21	B-103	B-119	B-138
			16200	2.13				15300	2.15				6165	21	B-103	B-119	B-138
58.0	1170	120	14400	1.05	70.0	972	99.1	13700	1.05	10 -	6145	- 25	B-102	B-118	B-137		
			16900	1.31				15900	1.31				6160	25	B-103	B-119	B-138
			16900	1.79				15900	2.01				6165	25	B-103	B-119	B-138
			19100	2.08				18000	2.11				6170	25	B-103	B-119	B-138
			19100	2.60				18000	2.60				6175	25	B-103	B-119	B-138
50.0	1360	139	14700	1.00	60.3	1130	115	14000	1.00	10 -	6145	- 29	B-102	B-118	B-137		
			17600	1.27				16600	1.40				6160	29	B-103	B-119	B-138
			17600	1.52				16600	1.52				6165	29	B-103	B-119	B-138
			20100	1.80				18900	1.91				6170	29	B-103	B-119	B-138
			20100	2.32				18900	2.51				6175	29	B-103	B-119	B-138
41.4	1640	167	18600	1.07	50.0	1360	139	17500	1.07	10 -	6160	- 35	B-103	B-119	B-138		
			14500	0.83				14900	1.00				6145	35	B-102	B-118	B-137
			18600	1.28				17500	1.52				6165	35	B-103	B-119	B-138
			21200	1.49				20000	1.60				6170	35	B-103	B-119	B-138
			21200	1.92				20000	2.01				6175	35	B-103	B-119	B-138
			28600	2.47				26900	2.51			6180	35	B-104	B-120	B-139	

1. Combinations in **bold** are the recommended models for operations for 10 hours/day with uniform load (service factor is about 1.0 for motor rating at 50Hz).
2. Motor slippage may affect n₁ and n₂. Refer to technical data for details.
3. CNHM, CHHM, CNFM, CHFM, CNVM, and CVVM indicate types. Refer to page B-10 for details.
4. Lubrication method is different for each model. Refer to "Lubrication" section in page F-4~F-5 for details.
5. "6" at the end of "input capacity symbol" indicates models with 6P motor. Other models come with 4P motor.

Selection Tables Gearmotors

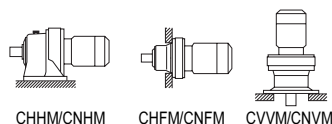

7.5 kW	Hz		50Hz		60Hz	
	P		4	6	4	6
	n ₁	r/min	1450	980	1750	1165

n₁: Motor Speed

50Hz					60Hz					Nomenclature			Page of Dimension Sheet					
Output Speed n ₂ r/min	Output Torque Tout		Allowable Radial Load Pro		SF	Output Speed n ₂ r/min	Output Torque Tout		Allowable Radial Load Pro		Input Capacity Symbol	Frame Size	Reduction Ratio	CNHM	CNFM	CNVM		
	N·m	kgf·m	N	kgf			N·m	kgf·m	N	kgf							CHHM	CHFM
33.7	2020	206	19700	2010	1.04	40.7	1670	170	18600	1900	1.05	10 -	6165	-	43	B-103	B-119	B-138
			22500	2300	1.21				21300	2170	1.30	10 -	6170	-	43	B-103	B-119	B-138
			22500	2300	1.51				21300	2170	1.51	10 -	6175	-	43	B-103	B-119	B-138
			30700	3130	2.01				28900	2950	2.01	10 -	6180	-	43	B-104	B-120	B-139
			30700	3130	2.48				28900	2950	2.51	10 -	6185	-	43	B-104	B-120	B-139
			42800	4370	2.79				40300	4110	2.79	10 -	6190	-	43	B-104	B-120	B-139
28.4	2390	244	20400	2080	0.88	34.3	1980	202	19300	1970	1.00	10 -	6165	-	51	B-103	B-119	B-138
			23400	2390	1.02				22100	2250	1.12	10 -	6170	-	51	B-103	B-119	B-138
			23400	2390	1.32				22100	2250	1.51	10 -	6175	-	51	B-103	B-119	B-138
			31700	3230	1.60				29900	3050	1.60	10 -	6180	-	51	B-104	B-120	B-139
			31700	3230	2.01				29900	3050	2.01	10 -	6185	-	51	B-104	B-120	B-139
			44800	4560	2.43				42100	4290	2.43	10 -	6190	-	51	B-104	B-120	B-139
24.6	2770	282	24400	2490	1.11	29.7	2290	234	23100	2360	1.11	10 -	6175	-	59	B-103	B-119	B-138
			33100	3380	1.30				31200	3180	1.30	10 -	6180	-	59	B-104	B-120	B-139
			33100	3380	1.60				31200	3180	1.60	10 -	6185	-	59	B-104	B-120	B-139
			46800	4770	2.04				44000	4490	2.04	10 -	6190	-	59	B-104	B-120	B-139
			46800	4770	2.51				44000	4490	2.51	10 -	6195	-	59	B-104	B-120	B-139
			25700	2620	0.93				24300	2480	0.95	10 -	6175	-	71	B-103	B-119	B-138
20.4	3330	340	35100	3580	1.17	24.6	2760	281	33100	3380	1.17	10 -	6180	-	71	B-104	B-120	B-139
			49600	5050	1.80				46700	4760	1.80	10 -	6190	-	71	B-104	B-120	B-139
			49600	5050	2.08				46700	4760	2.08	10 -	6195	-	71	B-104	B-120	B-139
			37700	3840	1.15				35600	3620	1.15	10 -	6185	-	87	B-104	B-120	B-139
			53300	5430	1.56				50200	5120	1.57	10 -	6190	-	87	B-104	B-120	B-139
			53300	5430	1.81				50200	5120	1.81	10 -	6195	-	87	B-104	B-120	B-139
13.9	4620	471	40000	4080	1.06	16.8	3830	391	37800	3850	1.28	10 -	6185DB	-	104	B-111	B-127	B-146
			56400	5750	1.38				53200	5420	1.59	10 -	6190DB	-	104	B-112	B-128	B-147
			56400	5750	1.59				53200	5420	1.59	10 -	6195DB	-	104	B-112	B-128	B-147
			4060	414	*1				4060	414	*1	10 -	6180DB	-	121	B-111	B-127	B-146
			41700	4250	0.89				40100	4090	1.08	10 -	6185DB	-	121	B-111	B-127	B-146
			59000	6010	1.19				56600	5770	1.43	10 -	6190DB	-	121	B-112	B-128	B-147
12.0	5380	548	59000	6010	1.41	14.5	4460	454	56600	5770	1.59	10 -	6195DB	-	121	B-112	B-128	B-147
			84100	8570	1.59				84100	8570	1.59	10 -	6205DB	-	121	B-112	B-129	B-148
			104000	10600	2.12				102000	10400	2.55	10 -	6215DB	-	121	B-113	B-130	B-149
			115000	11700	2.50				109000	11100	3.02	10 -	6225DB	-	121	B-113	B-130	B-149
			4060	414	*1				4060	414	*1	10 -	6180DB	-	143	B-111	B-127	B-146
			41700	4250	*1				41700	4250	*1	10 -	6185DB	-	143	B-111	B-127	B-146
10.1	4900	500	58700	5980	1.00	12.2	4900	500	58800	5990	1.21	10 -	6190DB	-	143	B-112	B-128	B-147
			58700	5980	1.20				58800	5990	1.45	10 -	6195DB	-	143	B-112	B-128	B-147
			4920	502	*1				4920	502	*1	10 -	6185DB	-	165	B-111	B-127	B-146
			58500	5960	1.08				59000	6010	1.30	10 -	6195DB	-	165	B-112	B-128	B-147
			84100	8570	1.26				84100	8570	1.53	10 -	6205DB	-	165	B-112	B-129	B-148
			104000	10600	1.59				104000	10600	1.59	10 -	6215DA	-	165	B-112	B-129	B-148
8.79	7340	748	104000	10600	1.66	10.6	6080	620	104000	10600	2.00	10 -	6215DB	-	165	B-113	B-130	B-149
			124000	12600	1.97				117000	12000	2.38	10 -	6225DB	-	165	B-113	B-130	B-149
			154000	15700	2.67				146000	14800	3.23	10 -	6235DA	-	165	B-114	B-131	B-150

GEARMOTORS
Selection Tables
7.5 kW

- "*2" indicate models manufactured with reducer and motor separately mounted on a common baseplate (horizontal shaft direction) or on an adaptor (vertical shaft direction). Consult us for details, including dimensions.
- Allowable radial load (Pro) is the value at the midpoint of the slow speed shaft.
- "*3" indicate models with reduction ratios equal to nominal ratio. Refer to Table A-3 "6000SK Series (Actual Reduction Ratio)" on page A-4 for actual reduction ratio. Indicated reduction ratio is the same as actual reduction ratio for other models.
- Maintain torque load during operation within "Output torque" in the table for models with "*" in the SF column. They cannot be operated with 100% motor rating.

Selection Tables Gearmotors

7.5 kW	Hz		50Hz		60Hz	
	P		4	6	4	6
	n ₁	r/min	1450	980	1750	1165

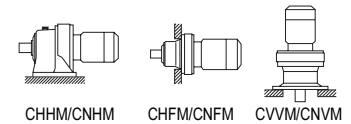

50Hz						60Hz						Nomenclature			Page of Dimension Sheet						
Output Speed n ₂ r/min	Output Torque T _{out}		Allowable Radial Load Pro		SF	Output Speed n ₂ r/min	Output Torque T _{out}		Allowable Radial Load Pro		SF	Input Capacity Symbol	Frame Size	Reduction Ratio	CNHM	CNFM	CNVM				
	N·m	kgf·m	N	kgf			N·m	kgf·m	N	kgf											
7.44	6380	650	58900	6000	*1	8.97	6380	650	58900	6000	*1	10 -	6190DB	- 195	B-112	B-128	B-147				
			58000	5910	0.91				58600	5970	1.10				B-112	B-128	B-147				
	84100	8570	1.07	84100	8570		1.29	10 - 6205DB	- 195	B-112	B-129				B-148						
	104000	10600	1.40	104000	10600		1.59	10 - 6215DA	- 195	B-112	B-129				B-148						
	104000	10600	1.40	104000	10600		1.69	10 - 6215DB	- 195	B-113	B-130				B-149						
	130000	13300	1.44	123000	12600		1.59	10 - 6225DA	- 195	B-113	B-130				B-149						
	130000	13300	1.67	123000	12600		2.02	10 - 6225DB	- 195	B-113	B-130				B-149						
6.28	6380	650	59000	6010	*1	7.58	6380	650	59000	6010	*1	10 -	6190DB	- 231	B-112	B-128	B-147				
			59000	6010	*1				59000	6010	*1				B-112	B-128	B-147				
	84100	8570	0.90	84100	8570		1.09	10 - 6205DB	- 231	B-112	B-129				B-148						
	104000	10600	1.22	104000	10600		1.47	10 - 6215DA	- 231	B-112	B-129				B-148						
	138000	14100	1.44	131000	13400		1.59	10 - 6225DA	- 231	B-113	B-130				B-149						
	138000	14100	1.44	131000	13400		1.74	10 - 6225DB	- 231	B-113	B-130				B-149						
	173000	17600	1.84	164000	16700		2.22	10 - 6235DA	- 231	B-114	B-131				B-150						
192000	19600	2.51	182000	18600	3.03	10 - 6245DA	- 231	B-114	B-131	B-150											
5.31	7960	811	59000	6010	*1	6.41	7960	811	59000	6010	*1	10 -	6195DB	- 273	B-112	B-128	B-147				
			84100	8570	*1				84100	8570	*1				B-112	B-129	B-148				
	104000	10600	1.03	104000	10600		1.24	10 - 6215DA	- 273	B-112	B-129				B-148						
	145000	14800	1.22	138000	14000		1.47	10 - 6225DA	- 273	B-113	B-130				B-149						
	179000	18200	1.56	172000	17500		1.88	10 - 6235DA	- 273	B-114	B-131				B-150						
	202000	20600	2.13	191000	19500		2.57	10 - 6245DA	- 273	B-114	B-131				B-150						
	246000	25100	2.55	233000	23700		3.08	10 - 6255DA	- 273	B-115	B-132				B-151						
4.55	14200	1450	104000	10600	0.89	5.49	11800	1200	104000	10600	1.08	10 -	6215DA	- 319	B-112	B-129	B-148				
			145000	14800	1.06				143000	14600	1.28				10 - 6225DA	- 319	B-113	B-130	B-149		
	179000	18200	1.33	179000	18200		1.61	10 - 6235DA	- 319	B-114	B-131				B-150						
	208000	21200	1.82	199000	20300		2.20	10 - 6245DA	- 319	B-114	B-131				B-150						
	258000	26300	2.29	245000	25000		2.76	10 - 6255DA	- 319	B-115	B-132				B-151						
	12700	1290	104000	10600	*1		4.64	12700	1290	104000	10600				*1	10 -	6215DA	- 377	B-112	B-129	B-148
	145000	14800	0.90	145000	14800					1.08	10 - 6225DA				- 377				B-113	B-130	B-149
179000	18200	1.13	179000	18200	1.36	10 - 6235DA		- 377	B-114	B-131	B-150										
208000	21200	1.54	208000	21200	1.86	10 - 6245DA		- 377	B-114	B-131	B-150										
258000	26300	1.94	257000	26200	2.34	10 - 6255DA		- 377	B-115	B-132	B-151										
276000	28100	2.74	276000	28100	3.31	10 - 6265DA		- 377	B-115	B-132	B-151										
16000	1630	145000	14800	*1	3.07	16000		1630	145000	14800	*1	10 -	6225DA	- 473	B-113				B-130	B-149	
179000	18200	0.97	179000	18200			1.18		10 - 6235DA	- 473	B-114				B-131	B-150					
208000	21200	1.23	208000	21200		1.48	10 - 6245DA	- 473	B-114	B-131	B-150										
258000	26300	1.64	258000	26300		1.98	10 - 6255DA	- 473	B-115	B-132	B-151										
276000	28100	2.19	276000	28100		2.64	10 - 6265DA	- 473	B-115	B-132	B-151										
16000	1630	145000	14800	*1		3.13	16000	1630	145000	14800	*1				10 -	6225DA	- 559	B-113	B-130	B-149	
20500	2090	179000	18200	*1					20500	2090	179000							18200	*1	B-114	B-131
179000	18200	0.82	179000	18200	1.00		10 - 6235DA	- 559	B-114	B-131	B-150										
208000	21200	1.04	208000	21200	1.25		10 - 6245DA	- 559	B-114	B-131	B-150										
24900	2530	258000	26300	1.39	20600		2100	258000	26300	1.68	10 - 6255DA	- 559	B-115	B-132				B-151			
276000	28100	1.85	276000	28100	2.23		10 - 6265DA	- 559	B-115	B-132	B-151										
248000	25300	2.74	248000	25300	3.31		10 - 6275DA	- 559	B-115	-	B-151										
20500	2090	179000	18200	*1	2.23	20500	2090	179000	18200	*1	10 -	6235DA	- 649	B-114	B-131	B-150					
208000	21200	0.89	208000	21200				1.08	10 - 6245DA	- 649				B-114	B-131	B-150					
258000	26300	1.20	258000	26300		1.44	10 - 6255DA	- 649	B-115	B-132				B-151							
276000	28100	1.59	276000	28100		1.92	10 - 6265DA	- 649	B-115	B-132				B-151							
248000	25300	2.36	248000	25300		2.85	10 - 6275DA	- 649	B-115	-				B-151							
20500	2090	179000	18200	*1		2.39	20500	2090	179000	18200				*1	10 -	6235DA	- 731	B-114	B-131	B-150	
25800	2630	208000	21200	*1					25800	2630				208000				21200	*1	B-114	B-131
258000	26300	1.06	258000	26300	1.28		10 - 6255DA	- 731	B-115	B-132	B-151										
32500	3310	276000	28100	1.42	26900		2740	276000	28100	1.71	10 - 6265DA	- 731	B-115	B-132				B-151			
248000	25300	2.10	248000	25300	2.53		10 - 6275DA	- 731	B-115	-	B-151										

1. Combinations in **bold** are the recommended models for operations for 10 hours/day with uniform load (service factor is about 1.0 for motor rating at 50Hz).
2. Motor slippage may affect n₁ and n₂. Refer to technical data for details.
3. CNHM, CHHM, CNFM, CHFM, CNVM, and CVVM indicate types. Refer to page B-10 for details.
4. Lubrication method is different for each model. Refer to "Lubrication" section in page F-4~F-5 for details.
5. "6" at the end of "input capacity symbol" indicates models with 6P motor. Other models come with 4P motor.

Selection Tables Gearmotors

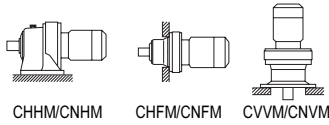

7.5 kW	Hz		50Hz		60Hz	
	P		4	6	4	6
	n ₁	r/min	1450	980	1750	1165

50Hz						60Hz					Nomenclature			Page of Dimension Sheet						
Output Speed n ₂ r/min	Output Torque Tout		Allowable Radial Load Pro		SF	Output Speed n ₂ r/min	Output Torque Tout		Allowable Radial Load Pro		SF	Input Capacity - Symbol	Frame Size - Ratio	Reduction Ratio	CNHM	CNFM	CNVM			
	N·m	kgf·m	N	kgf			N·m	kgf·m	N	kgf								CHHM	CHF	CVVM
1.72	25800	2630	208000	21200	*1	2.08	25800	2630	208000	21200	*1	10 -	6245DA -	841	B-114	B-131	B-150			
			258000	26300	0.87				258000	26300	1.05				B-115	B-132	B-151			
	37400	3810	276000	28100	1.23		31000	3160	276000	28100	1.48				10 -	6265DA -	841	B-115	B-132	B-151
			248000	25300	1.82				248000	25300	2.20				10 -	6275DA -	841	B-115	-	B-151
1.45	34500	3520	258000	26300	*1	1.74	34500	3520	258000	26300	*1	10 -	6255DA -	1003	B-115	B-132	B-151			
			276000	28100	1.03				276000	28100	1.25				10 -	6265DA -	1003	B-115	B-132	B-151
1.16	44600	4550	248000	25300	1.53	1.40	36900	3770	248000	25300	1.85	10 -	6275DA -	1003	B-115	-	B-151			
			276000	28100	*1				276000	28100	*1				10 -	6255DA -	1247	B-115	B-132	B-151
0.980	34500	3520	258000	26300	*1	1.18	34500	3520	258000	26300	*1	10 -	6255DA -	1247	B-115	B-132	B-151			
			276000	28100	*1				276000	28100	1.00				10 -	6265DA -	1247	B-115	B-132	B-151
			46000	4690	276000				28100	0.83	46000				4690	276000	28100	*1	10 -	6265DA -
0.784	55400	5650	276000	28100	1.23	1.18	45900	4680	276000	28100	1.48	10 -	6275DA -	1247	B-115	-	B-151			
			248000	25300	1.04				248000	25300	1.25				10 -	6275DA -	1479	B-115	-	B-151
0.702	82200	8380	248000	25300	0.83	0.946	68100	6940	248000	25300	1.00	10 -	6275DA -	1849	B-115	-	B-151			
0.572	68200	6950	248000	25300	*1	0.847	68200	6950	248000	25300	*1	10 -	6275DA -	2065	B-115	-	B-151			
0.476	68200	6950	245000	25000	*1	0.690	68200	6950	248000	25300	*1	10 -	6275DA -	2537	B-115	-	B-151			
0.417	68200	6950	248000	25300	*1	0.575	68200	6950	245000	25000	*1	10 -	6275DA -	3045	B-115	-	B-151			
0.327	68200	6950	245000	25000	*1	0.503	68200	6950	248000	25300	*1	10 -	6275DA -	3481	B-115	-	B-151			
0.282	68200	6950	245000	25000	*1	0.394	68200	6950	245000	25000	*1	10 -	6275DA -	4437	B-115	-	B-151			
0.235	68200	6950	245000	25000	*1	0.341	68200	6950	245000	25000	*1	10 -	6275DA -	5133	B-115	-	B-151			
0.192	68200	6950	245000	25000	*1	0.283	68200	6950	245000	25000	*1	10 -	6275DA -	6177	B-115	-	B-151			
						0.231	68200	6950	245000	25000	*1	10 -	6275DA -	7569	B-115	-	B-151			

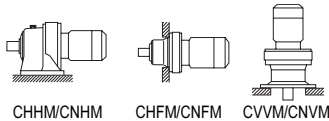

11 kW	Hz		50Hz		60Hz	
	P		4	6	4	6
	n ₁	r/min	1450	980	1750	1165

50Hz						60Hz					Nomenclature			Page of Dimension Sheet						
Output Speed n ₂ r/min	Output Torque Tout		Allowable Radial Load Pro		SF	Output Speed n ₂ r/min	Output Torque Tout		Allowable Radial Load Pro		SF	Input Capacity - Symbol	Frame Size - Ratio	Reduction Ratio	CNHM	CNFM	CNVM			
	N·m	kgf·m	N	kgf			N·m	kgf·m	N	kgf								CHHM	CHF	CVVM
242	413	42.1	5840	595	1.03	292	342	34.9	5540	564	1.03	15 -	6135 -	6	B-102	B-118	B-137			
			9270	945	1.18				8780	895	1.18				15 -	6140 -	6	B-102	B-118	B-137
			9270	945	1.37				8780	895	1.37				15 -	6145 -	6	B-102	B-118	B-137
			10400	1060	1.85				9760	995	1.85				15 -	6160 -	6	B-103	B-119	B-138
			10400	1060	2.19				9760	995	2.19				15 -	6165 -	6	B-103	B-119	B-138
			11700	1190	2.51				11000	1120	2.51				15 -	6170 -	6	B-103	B-119	B-138
			11700	1190	2.74				11000	1120	2.74				15 -	6175 -	6	B-103	B-119	B-138
181	551	56.1	6480	661	1.03	219	456	46.5	6150	627	1.03	15 -	6135 -	8	B-102	B-118	B-137			
			10300	1050	1.18				9730	992	1.18				15 -	6140 -	8	B-102	B-118	B-137
			10300	1050	1.37				9730	992	1.37				15 -	6145 -	8	B-102	B-118	B-137
			11600	1180	1.79				10900	1110	1.79				15 -	6160 -	8	B-103	B-119	B-138
			11600	1180	2.19				10900	1110	2.19				15 -	6165 -	8	B-103	B-119	B-138
			12900	1320	2.51				12200	1240	2.51				15 -	6170 -	8	B-103	B-119	B-138
			12900	1320	2.74				12200	1240	2.74	15 -	6175 -	8	B-103	B-119	B-138			

- "*2" indicate models manufactured with reducer and motor separately mounted on a common baseplate (horizontal shaft direction) or on an adaptor (vertical shaft direction). Consult us for details, including dimensions.
- Allowable radial load (Pro) is the value at the midpoint of the slow speed shaft.
- "*3" indicate models with reduction ratios equal to nominal ratio. Refer to Table A-3 "6000SK Series (Actual Reduction Ratio)" on page A-4 for actual reduction ratio. Indicated reduction ratio is the same as actual reduction ratio for other models.
- Maintain torque load during operation within "Output torque" in the table for models with "*"1" in the SF column. They cannot be operated with 100% motor rating.

GEARMOTORS
Selection Tables
7.5 kW, 11 kW

Selection Tables Gearmotors

11 kW	Hz		50Hz		60Hz	
	P		4	6	4	6
	n ₁	r/min	1450	980	1750	1165

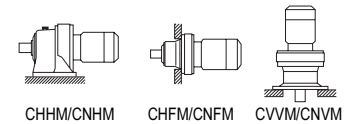

50Hz						60Hz						Nomenclature			Page of Dimension Sheet					
Output Speed n ₂ r/min	Output Torque T _{out} N·m	kgf·m	Allowable Radial Load Pro N	kgf	SF	Output Speed n ₂ r/min	Output Torque T _{out} N·m	kgf·m	Allowable Radial Load Pro N	kgf	SF	Input Capacity Symbol	Frame Size	Reduction Ratio	CNHM CHHM	CNFM CHFM	CNVM CVVM			
132	757	77.2	7360	750	1.03	159	627	63.9	6980	712	1.03	15 -	6135	- 11	B-102	B-118	B-137			
			11500	1170	1.18				10900	1110	1.18				6140	- 11	B-102	B-118	B-137	
			11500	1170	1.37				10900	1110	1.37				6145	- 11	B-102	B-118	B-137	
			13100	1330	1.79				12300	1260	1.79				6160	- 11	B-103	B-119	B-138	
			13100	1330	2.19				12300	1260	2.19				6165	- 11	B-103	B-119	B-138	
			14900	1520	2.51				14000	1430	2.51				6170	- 11	B-103	B-119	B-138	
			14900	1520	2.74				14000	1430	2.74				6175	- 11	B-103	B-119	B-138	
112	895	91.2	11700	1200	1.18	135	741	75.6	11100	1140	1.18	15 -	6140	- 13	B-102	B-118	B-137			
			11700	1200	1.37				11100	1140	1.37				6145	- 13	B-102	B-118	B-137	
			13700	1390	1.79				12900	1320	1.79				6160	- 13	B-103	B-119	B-138	
			13700	1390	2.05				12900	1320	2.05				6165	- 13	B-103	B-119	B-138	
			15500	1580	2.48				14600	1490	2.48				6170	- 13	B-103	B-119	B-138	
15500	1580	2.74	14600	1490	2.74	6175	- 13	B-103	B-119	B-138										
96.7	1030	105	12300	1250	1.09	117	855	87.2	11600	1190	1.09	15 -	6140	- 15	B-102	B-118	B-137			
			12300	1250	1.32				11600	1190	1.32				6145	- 15	B-102	B-118	B-137	
			14500	1470	1.70				13600	1390	1.70				6160	- 15	B-103	B-119	B-138	
			14500	1470	2.04				13600	1390	2.04				6165	- 15	B-103	B-119	B-138	
			16300	1660	2.32				15400	1570	2.32				6170	- 15	B-103	B-119	B-138	
			16300	1660	2.74				15400	1570	2.74				6175	- 15	B-103	B-119	B-138	
			21700	2210	2.95				20400	2080	2.95				6180	- 15	B-104	B-120	B-139	
85.3	1170	119	12800	1300	1.09	103	969	98.8	12100	1240	1.09	15 -	6145	- 17	B-102	B-118	B-137			
			14900	1520	1.19				14100	1430	1.19				6160	- 17	B-103	B-119	B-138	
			14900	1520	1.71				14100	1430	1.71				6165	- 17	B-103	B-119	B-138	
			16900	1720	1.79				16000	1630	1.79				6170	- 17	B-103	B-119	B-138	
			16900	1720	2.19				16000	1630	2.19				6175	- 17	B-103	B-119	B-138	
			22900	2340	2.78				21600	2200	2.78				6180	- 17	B-104	B-120	B-139	
69.0	1450	147	13600	1390	0.86	83.3	1200	122	12900	1320	1.00	15 -	6145	- 21	B-102	B-118	B-137			
			15900	1620	1.17				15000	1530	1.17				15 -	6160	- 21	B-103	B-119	B-138
			15900	1620	1.45				15000	1530	1.46				6165	- 21	B-103	B-119	B-138	
			18200	1860	1.69				17200	1750	1.77				6170	- 21	B-103	B-119	B-138	
			18200	1860	2.15				17200	1750	2.19				6175	- 21	B-103	B-119	B-138	
24500	2500	2.73	23100	2350	2.73	6180	- 21	B-104	B-120	B-139										
58.0	1720	175	16600	1690	1.22	70.0	1430	145	15700	1600	1.37	15 -	6165	- 25	B-103	B-119	B-138			
			18800	1920	1.42				17800	1810	1.44				6170	- 25	B-103	B-119	B-138	
			18800	1920	1.77				17800	1810	1.77				6175	- 25	B-103	B-119	B-138	
			25500	2600	2.19				24000	2450	2.19				6180	- 25	B-104	B-120	B-139	
			25500	2600	2.74				24000	2450	2.74				6185	- 25	B-104	B-120	B-139	
50.0	2000	203	17200	1750	1.04	60.3	1650	169	16300	1660	1.04	15 -	6165	- 29	B-103	B-119	B-138			
			19800	2010	1.23				18700	1900	1.30				6170	- 29	B-103	B-119	B-138	
			19800	2010	1.58				18700	1900	1.71				6175	- 29	B-103	B-119	B-138	
			26600	2710	1.77				25100	2560	1.77				6180	- 29	B-104	B-120	B-139	
			26600	2710	2.19				25100	2560	2.19				6185	- 29	B-104	B-120	B-139	
			37500	3830	2.79				35300	3600	2.79				6190	- 29	B-104	B-120	B-139	
41.4	2410	246	18100	1840	0.87	50.0	2000	203	17100	1750	1.04	15 -	6165	- 35	B-103	B-119	B-138			
			20900	2130	1.02				19700	2010	1.09				15 -	6170	- 35	B-103	B-119	B-138
			20900	2130	1.31				19700	2010	1.37				6175	- 35	B-103	B-119	B-138	
			28400	2890	1.68				26700	2730	1.71				6180	- 35	B-104	B-120	B-139	
			28400	2890	2.05				26700	2730	2.05				6185	- 35	B-104	B-120	B-139	
			39600	4040	2.21				37300	3800	2.21				6190	- 35	B-104	B-120	B-139	
			39600	4040	2.74				37300	3800	2.74				6195	- 35	B-104	B-120	B-139	
33.7	2960	302	22100	2250	1.03	40.7	2450	250	20900	2130	1.03	15 -	6175	- 43	B-103	B-119	B-138			
			30300	3090	1.37				28600	2920	1.37				6180	- 43	B-104	B-120	B-139	
			30300	3090	1.69				28600	2920	1.71				6185	- 43	B-104	B-120	B-139	
			42600	4340	1.90				40100	4090	1.90				6190	- 43	B-104	B-120	B-139	
			42600	4340	2.46				40100	4090	2.74				6195	- 43	B-104	B-120	B-139	
			77700	7920	2.89				73500	7500	2.89				6205	- 43	B-105	B-121	B-140	

1. Combinations in **bold** are the recommended models for operations for 10 hours/day with uniform load (service factor is about 1.0 for motor rating at 50Hz).
2. Motor slippage may affect n₁ and n₂. Refer to technical data for details.
3. CNHM, CHHM, CNFM, CHFM, CNVM, and CVVM indicate types. Refer to page B-10 for details.
4. Lubrication method is different for each model. Refer to "Lubrication" section in page F-4~F-5 for details.
5. "6" at the end of "input capacity symbol" indicates models with 6P motor. Other models come with 4P motor.

Selection Tables Gearmotors

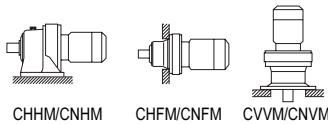

11 kW	Hz		50Hz		60Hz	
	P		4	6	4	6
	n ₁	r/min	1450	980	1750	1165

50Hz						60Hz						Nomenclature			Page of Dimension Sheet		
Output Speed n ₂ r/min	Output Torque T _{out}		Allowable Radial Load Pro		SF	Output Speed n ₂ r/min	Output Torque T _{out}		Allowable Radial Load Pro		SF	Input Capacity Symbol	Frame Size	Reduction Ratio	CNHM	CNFM	CNVM
	N·m	kgf·m	N	kgf			N·m	kgf·m	N	kgf							
28.4	3510	358	22900	2330	0.90	34.3	2910	296	21700	2210	1.03	15 -	6175	- 51	B-103	B-119	B-138
			31300	3200	1.09				29600	3010	1.09	15 -	6180	- 51	B-104	B-120	B-139
			31300	3200	1.37				29600	3010	1.37	15 -	6185	- 51	B-104	B-120	B-139
			44400	4530	1.65				41900	4270	1.65	15 -	6190	- 51	B-104	B-120	B-139
24.6	4060	414	44400	4530	1.90	29.7	3360	343	41900	4270	1.90	15 -	6195	- 51	B-104	B-120	B-139
			32700	3330	1.09				30900	3150	1.09	15 -	6185	- 59	B-104	B-120	B-139
			46400	4730	1.39				43700	4460	1.39	15 -	6190	- 59	B-104	B-120	B-139
			46400	4730	1.71				43700	4460	1.71	15 -	6195	- 59	B-104	B-120	B-139
20.4	4890	498	84100	8570	2.05	24.6	4050	413	79900	8150	2.05	15 -	6205	- 59	B-105	B-121	B-140
			34500	3520	0.89				32700	3330	0.89	15 -	6185	- 71	B-104	B-120	B-139
			49100	5010	1.23				46300	4720	1.23	15 -	6190	- 71	B-104	B-120	B-139
			49100	5010	1.42				46300	4720	1.42	15 -	6195	- 71	B-104	B-120	B-139
16.7	5990	610	52700	5380	1.06	20.1	4960	506	49700	5070	1.07	15 -	6190	- 87	B-104	B-120	B-139
			52700	5380	1.24				49700	5070	1.24	15 -	6195	- 87	B-104	B-120	B-139
			84100	8570	1.45				84100	8570	1.45	15 -	6205	- 87	B-105	B-121	B-140
			96600	9850	1.79				91500	9320	1.95	15 -	6215	- 87	B-106	B-121	B-140
13.9	4060	414	40200	4100	*1	16.8	4060	414	37700	3840	*1	15 -	6180DB	- 104	B-111	B-127	B-146
	4900	500	39900	4060	*1		4900	500	37300	3800	*1	15 -	6185DB	- 104	B-111	B-127	B-146
	6780	691	55600	5670	1.08		5620	573	52500	5360	1.08	15 -	6195DB	- 104	B-112	B-128	B-147
12.0	4810	490	41700	4250	*1	14.5	4810	490	40000	4070	*1	15 -	6185DB	- 121	B-111	B-127	B-146
	6380	650	59000	6010	*1		6380	650	55900	5700	*1	15 -	6190DB	- 121	B-112	B-128	B-147
			59000	6010	0.96				55900	5700	1.08	15 -	6195DB	- 121	B-112	B-128	B-147
			84100	8570	1.08				84100	8570	1.08	15 -	6205DB	- 121	B-112	B-129	B-148
			104000	10600	1.44				102000	10400	1.74	15 -	6215DB	- 121	B-113	B-130	B-149
			114000	11600	1.71				108000	11000	2.06	15 -	6225DB	- 121	B-113	B-130	B-149
			143000	14600	2.31				135000	13800	2.31	15 -	6235DA	- 121	B-114	B-131	B-150
			143000	14600	2.37				135000	13800	2.86	15 -	6235DB	- 121	B-114	B-131	B-150
10.1	6380	650	58700	5980	*1	12.2	6380	650	58400	5950	*1	15 -	6190DB	- 143	B-112	B-128	B-147
	7630	778	58200	5940	*1		7630	778	57900	5900	*1	15 -	6195DB	- 143	B-112	B-128	B-147
	9320	950	57600	5870	0.82		7730	788	57900	5900	0.98	15 -	6195DB	- 143	B-112	B-128	B-147
8.79	6380	650	58900	6000	*1	10.6	6380	650	58900	6000	*1	15 -	6190DB	- 165	B-112	B-128	B-147
	7910	806	58300	5940	*1		7910	806	58300	5940	*1	15 -	6195DB	- 165	B-112	B-128	B-147
			84100	8570	0.86				84100	8570	1.04	15 -	6205DB	- 165	B-112	B-129	B-148
			104000	10600	1.08				104000	10600	1.08	15 -	6215DA	- 165	B-112	B-130	B-148
			104000	10600	1.13				104000	10600	1.37	15 -	6215DB	- 165	B-113	B-130	B-149
			123000	12600	1.35				117000	11900	1.62	15 -	6225DB	- 165	B-113	B-130	B-149
			153000	15600	1.82				145000	14800	2.20	15 -	6235DA	- 165	B-114	B-131	B-150
			171000	17400	2.31				162000	16500	2.31	15 -	6245DA	- 165	B-114	B-131	B-150
7.44			171000	17400	2.44	8.79			162000	16500	2.94	15 -	6245DB	- 165	B-114	B-131	B-150
			209000	21300	2.89				198000	20200	2.89	15 -	6255DA	- 165	B-115	B-132	B-151
			209000	21300	2.90				198000	20200	3.50	15 -	6255DB	- 165	B-115	B-132	B-151
	7910	806	58300	5940	*1		7910	806	58300	5940	*1	15 -	6195DB	- 195	B-112	B-128	B-147
	9270	945	84100	8570	*1		9270	945	84100	8570	*1	15 -	6205DB	- 195	B-112	B-129	B-148
			104000	10600	0.96				104000	10600	1.08	15 -	6215DA	- 195	B-112	B-130	B-148
			104000	10600	0.96				104000	10600	1.16	15 -	6215DB	- 195	B-113	B-130	B-149
			129000	13200	0.98				122000	12500	1.08	15 -	6225DA	- 195	B-113	B-130	B-149
			129000	13200	1.14				122000	12500	1.37	15 -	6225DB	- 195	B-113	B-130	B-149
			161000	16400	1.54				152000	15500	1.86	15 -	6235DA	- 195	B-114	B-131	B-150
		180000	18300	2.06			170000	17300	2.17	15 -	6245DA	- 195	B-114	B-131	B-150		
		180000	18300	2.06			170000	17300	2.49	15 -	6245DB	- 195	B-114	B-131	B-150		
		220000	22400	2.45			208000	21200	2.89	15 -	6255DA	- 195	B-115	B-132	B-151		
		220000	22400	2.45			208000	21200	2.96	15 -	6255DB	- 195	B-115	B-132	B-151		

- "*2" indicate models manufactured with reducer and motor separately mounted on a common baseplate (horizontal shaft direction) or on an adaptor (vertical shaft direction). Consult us for details, including dimensions.
- Allowable radial load (Pro) is the value at the midpoint of the slow speed shaft.
- "*3" indicate models with reduction ratios equal to nominal ratio. Refer to Table A-3 "6000SK Series (Actual Reduction Ratio)" on page A-4 for actual reduction ratio. Indicated reduction ratio is the same as actual reduction ratio for other models.
- Maintain torque load during operation within "Output torque" in the table for models with "*"1" in the SF column. They cannot be operated with 100% motor rating.

Selection Tables 11 kW GEARMOTORS

Selection Tables Gearmotors

11 kW	Hz		50Hz		60Hz	
	P		4	6	4	6
	n ₁	r/min	1450	980	1750	1165

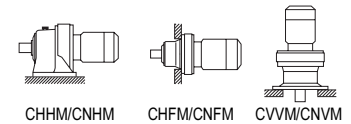

50Hz						60Hz						Nomenclature			Page of Dimension Sheet		
Output Speed n ₂ r/min	Output Torque T _{out}		Allowable Radial Load Pro		SF	Output Speed n ₂ r/min	Output Torque T _{out}		Allowable Radial Load Pro		SF	Input Capacity Symbol	Frame Size	Reduction Ratio	CNHM	CNFM	CNVM
	N·m	kgf·m	N	kgf			N·m	kgf·m	N	kgf							
6.28	9270	945	84100	8570	*1	7.58	9270	945	84100	8570	*1	15 - 6205DB	- 231	B-112	B-129	B-148	
	12500	1270	104000	10600	*1		12500	1270	104000	10600	*1	15 - 6215DA	- 231	B-112	B-130	B-148	
	15100	1540	104000	10600	0.83		12500	1270	104000	10600	1.00	15 - 6215DA	- 231	B-112	B-130	B-148	
			137000	14000	0.98				130000	13300	1.08	15 - 6225DA	- 231	B-113	B-130	B-149	
			137000	14000	0.98				130000	13300	1.19	15 - 6225DB	- 231	B-113	B-130	B-149	
			172000	17500	1.25				163000	16600	1.51	15 - 6235DA	- 231	B-114	B-131	B-150	
191000	19500	1.71	181000	18500	2.07	15 - 6245DA	- 231	B-114	B-131	B-150							
233000	23800	2.06	221000	22500	2.48	15 - 6255DA	- 231	B-115	B-132	B-151							
5.31	12500	1270	104000	10600	*1	6.41	12500	1270	104000	10600	*1	15 - 6215DA	- 273	B-112	B-130	B-148	
	14800	1510	145000	14700	*1		14800	1510	137000	13900	*1	15 - 6225DA	- 273	B-113	B-130	B-149	
	17800	1810	144000	14700	0.83		14700	1500	137000	13900	1.00	15 - 6225DA	- 273	B-113	B-130	B-149	
			179000	18200	1.06				171000	17400	1.28	15 - 6235DA	- 273	B-114	B-131	B-150	
			201000	20500	1.45				190000	19400	1.75	15 - 6245DA	- 273	B-114	B-131	B-150	
			245000	25000	1.74				232000	23600	2.10	15 - 6255DA	- 273	B-115	B-132	B-151	
276000	28100	2.58	276000	28100	3.12	15 - 6265DA	- 273	B-115	B-132	B-151							
4.55	12700	1290	104000	10600	*1	5.49	12700	1290	104000	10600	*1	15 - 6215DA	- 319	B-112	B-130	B-148	
	15000	1530	145000	14800	*1		15000	1530	142000	14500	*1	15 - 6225DA	- 319	B-113	B-130	B-149	
	20800	2120	179000	18200	0.91		17200	1760	177000	18100	1.10	15 - 6235DA	- 319	B-114	B-131	B-150	
			208000	21200	1.24				198000	20200	1.50	15 - 6245DA	- 319	B-114	B-131	B-150	
			258000	26300	1.56				244000	24900	1.88	15 - 6255DA	- 319	B-115	B-132	B-151	
			276000	28100	2.21				276000	28100	2.67	15 - 6265DA	- 319	B-115	B-132	B-151	
3.85	15000	1530	145000	14800	*1	4.64	15000	1530	145000	14800	*1	15 - 6225DA	- 377	B-113	B-130	B-149	
	18900	1930	179000	18200	*1		18900	1930	179000	18200	*1	15 - 6235DA	- 377	B-114	B-131	B-150	
	24600	2510	208000	21200	1.05		20400	2080	208000	21200	1.27	15 - 6245DA	- 377	B-114	B-131	B-150	
			258000	26300	1.32				256000	26100	1.59	15 - 6255DA	- 377	B-115	B-132	B-151	
			276000	28100	1.87				276000	28100	2.26	15 - 6265DA	- 377	B-115	B-132	B-151	
			248000	25300	2.77				248000	25300	3.35	15 - 6275DA	- 377	B-115	-	B-151	
3.07	20500	2090	179000	18200	*1	3.70	20500	2090	179000	18200	*1	15 - 6235DA	- 473	B-114	B-131	B-150	
	30800	3140	208000	21200	0.84		25600	2600	208000	21200	1.01	15 - 6245DA	- 473	B-114	B-131	B-150	
			258000	26300	1.12				258000	26300	1.35	15 - 6255DA	- 473	B-115	B-132	B-151	
			276000	28100	1.49				276000	28100	1.80	15 - 6265DA	- 473	B-115	B-132	B-151	
			248000	25300	2.21				248000	25300	2.67	15 - 6275DA	- 473	B-115	-	B-151	
			25800	2630	208000				21200	*1	25800	2630	208000	21200	*1	15 - 6245DA	- 559
36400	3720	276000	28100	1.26	30200	3080	276000	28100	1.52	15 - 6265DA	- 559	B-115	B-132	B-151			
2.23	25800	2630	208000	21200	*1	2.70	25800	2630	208000	21200	*1	15 - 6245DA	- 649	B-114	B-131	B-150	
	34500	3520	258000	26300	*1		34500	3520	258000	26300	*1	15 - 6255DA	- 649	B-115	B-132	B-151	
	42300	4310	258000	26300	0.82		35100	3570	258000	26300	0.98	15 - 6255DA	- 649	B-115	B-132	B-151	
			276000	28100	1.09				276000	28100	1.31	15 - 6265DA	- 649	B-115	B-132	B-151	
			248000	25300	1.61				248000	25300	1.95	15 - 6275DA	- 649	B-115	-	B-151	
			34500	3520	258000				26300	*1	34500	3520	258000	26300	*1	15 - 6255DA	- 731
1.98	47700	4860	276000	28100	0.97	2.39	39500	4030	276000	28100	1.16	15 - 6265DA	- 731	B-115	B-132	B-151	
			248000	25300	1.43				248000	25300	1.73	15 - 6275DA	- 731	B-115	-	B-151	
			32500	3310	258000				26300	*1	32500	3310	258000	26300	*1	15 - 6255DA	- 841
1.72	54800	5590	276000	28100	0.84	2.08	45400	4630	276000	28100	1.01	15 - 6265DA	- 841	B-115	B-132	B-151	
			248000	25300	1.24				248000	25300	1.50	15 - 6275DA	- 841	B-115	-	B-151	
1.45	65400	6670	276000	28100	*1	1.74	54200	5520	276000	28100	*1	15 - 6265DA	- 1003	B-115	B-132	B-151	
			248000	25300	1.04				248000	25300	1.26	15 - 6275DA	- 1003	B-115	-	B-151	
1.16	81300	8290	248000	25300	0.84	1.40	67400	6870	248000	25300	1.01	15 - 6275DA	- 1247	B-115	-	B-151	
0.980	68200	6950	245000	25000	*1	1.18	68200	6950	245000	25000	*1	15 - 6275DA	- 1479	B-115	-	B-151	

1. Combinations in **bold** are the recommended models for operations for 10 hours/day with uniform load (service factor is about 1.0 for motor rating at 50Hz).
2. Motor slippage may affect n₁ and n₂. Refer to technical data for details.
3. CNHM, CHHM, CNFM, CHFM, CNVM, and CVVM indicate types. Refer to page B-10 for details.
4. Lubrication method is different for each model. Refer to "Lubrication" section in page F-4~F-5 for details.
5. "6" at the end of "input capacity symbol" indicates models with 6P motor. Other models come with 4P motor.

Selection Tables Gearmotors

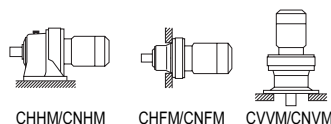

15 kW	Hz		50Hz		60Hz	
	P		4	6	4	6
	n ₁	r/min	1450	980	1750	1165

n₁: Motor Speed

50Hz					60Hz					Nomenclature			Page of Dimension Sheet							
Output Speed n ₂ r/min	Output Torque Tout		Allowable Radial Load Pro		SF	Output Speed n ₂ r/min	Output Torque Tout		Allowable Radial Load Pro		Input Capacity Symbol	Frame Size	Reduction Ratio	CNHM	CNFM	CNVM				
	N·m	kgf·m	N	kgf			N·m	kgf·m	N	kgf							CHHM	CHFM	CVVM	
242	563	57.4	9200	938	1.01	292	467	47.6	8730	889	1.01	20 -	6145	-	6	B-102	B-118	B-137		
			10200	1040	1.35				9670	986	1.35					6160	6	B-103	B-119	B-138
			10200	1040	1.61				9670	986	1.61					6165	6	B-103	B-119	B-138
			11600	1180	1.84				10900	1110	1.84					6170	6	B-103	B-119	B-138
			11600	1180	2.01				10900	1110	2.01					6175	6	B-103	B-119	B-138
181	751	76.5	10200	1040	1.01	219	622	63.4	9660	984	1.01	20 -	6145	-	8	B-102	B-118	B-137		
			11400	1170	1.31				10800	1100	1.31					6160	8	B-103	B-119	B-138
			11400	1170	1.61				10800	1100	1.61					6165	8	B-103	B-119	B-138
			12800	1310	1.84				12100	1230	1.84					6170	8	B-103	B-119	B-138
			12800	1310	2.01				12100	1230	2.01					6175	8	B-103	B-119	B-138
132	1030	105	11400	1160	1.01	159	855	87.2	10800	1100	1.01	20 -	6145	-	11	B-102	B-118	B-137		
			12900	1320	1.31				12200	1240	1.31					6160	11	B-103	B-119	B-138
			12900	1320	1.61				12200	1240	1.61					6165	11	B-103	B-119	B-138
			14700	1500	1.84				13900	1420	1.84					6170	11	B-103	B-119	B-138
			14700	1500	2.01				13900	1420	2.01					6175	11	B-103	B-119	B-138
			19600	2000	2.35				18500	1880	2.35					6180	11	B-104	B-120	B-139
			19600	2000	2.60				18500	1880	2.60					6185	11	B-104	B-120	B-139
27500	2800	2.73	25800	2630	2.73	6190	11	B-104	B-120	B-139										
112	1220	124	11600	1190	1.01	135	1010	103	11000	1130	1.01	20 -	6145	-	13	B-102	B-118	B-137		
			13500	1370	1.31				12700	1300	1.31					6160	13	B-103	B-119	B-138
			13500	1370	1.51				12700	1300	1.51					6165	13	B-103	B-119	B-138
			15300	1560	1.82				14500	1470	1.82					6170	13	B-103	B-119	B-138
			15300	1560	2.01				14500	1470	2.01					6175	13	B-103	B-119	B-138
			20400	2080	2.35				19200	1960	2.35					6180	13	B-104	B-120	B-139
			20400	2080	2.60				19200	1960	2.60					6185	13	B-104	B-120	B-139
28600	2910	2.73	26900	2740	2.73	6190	13	B-104	B-120	B-139										
96.7	1410	144	12100	1240	0.97	117	1170	119	11500	1170	1.01	20 -	6145	-	15	B-102	B-118	B-137		
			14200	1450	1.25				13500	1370	1.25					6160	15	B-103	B-119	B-138
			14200	1450	1.49				13500	1370	1.51					6165	15	B-103	B-119	B-138
			16100	1640	1.70				15200	1550	1.70					6170	15	B-103	B-119	B-138
			16100	1640	2.01				15200	1550	2.01					6175	15	B-103	B-119	B-138
			21600	2200	2.16				20300	2070	2.16					6180	15	B-104	B-120	B-139
			21600	2200	2.60				20300	2070	2.60					6185	15	B-104	B-120	B-139
30000	3060	2.73	28200	2880	2.73	6190	15	B-104	B-120	B-139										
85.3	1600	163	12600	1290	0.80	103	1320	135	12000	1220	0.80	20 -	6145	-	17	B-102	B-118	B-137		
			14600	1490	1.25				13900	1410	1.25					6165	17	B-103	B-119	B-138
			16700	1700	1.31				15800	1610	1.31					6170	17	B-103	B-119	B-138
			16700	1700	1.61				15800	1610	1.61					6175	17	B-103	B-119	B-138
			22700	2320	2.04				21400	2180	2.04					6180	17	B-104	B-120	B-139
22700	2320	2.55	21400	2180	2.60	6185	17	B-104	B-120	B-139										
31600	3220	2.73	29800	3030	2.73	6190	17	B-104	B-120	B-139										
69.0	1970	201	15600	1590	1.07	83.3	1630	166	14800	1510	1.07	20 -	6165	-	21	B-103	B-119	B-138		
			17900	1830	1.24				17000	1730	1.30					6170	21	B-103	B-119	B-138
			17900	1830	1.57				17000	1730	1.61					6175	21	B-103	B-119	B-138
			24300	2480	2.00				22900	2340	2.00					6180	21	B-104	B-120	B-139
			24300	2480	2.54				22900	2340	2.60					6185	21	B-104	B-120	B-139
			34000	3470	2.73				32000	3260	2.73					6190	21	B-104	B-120	B-139
58.0	2350	239	16200	1650	0.89	70.0	1940	198	15400	1570	1.01	20 -	6165	-	25	B-103	B-119	B-138		
			18500	1890	1.04				17500	1780	1.05					6170	25	B-103	B-119	B-138
			18500	1890	1.30				17500	1780	1.30					6175	25	B-103	B-119	B-138
			25300	2580	1.61				23800	2430	1.61					6180	25	B-104	B-120	B-139
			25300	2580	2.01				23800	2430	2.01					6185	25	B-104	B-120	B-139
			35600	3620	2.35				33500	3410	2.35					6190	25	B-104	B-120	B-139
35600	3620	2.70	33500	3410	2.70	6195	25	B-104	B-120	B-139										

GEARMOTORS
Selection Tables
15 kW

- "*2" indicate models manufactured with reducer and motor separately mounted on a common baseplate (horizontal shaft direction) or on an adaptor (vertical shaft direction). Consult us for details, including dimensions.
- Allowable radial load (Pro) is the value at the midpoint of the slow speed shaft.
- "*3" indicate models with reduction ratios equal to nominal ratio. Refer to Table A-3 "6000SK Series (Actual Reduction Ratio)" on page A-4 for actual reduction ratio. Indicated reduction ratio is the same as actual reduction ratio for other models.
- Maintain torque load during operation within "Output torque" in the table for models with "*" in the SF column. They cannot be operated with 100% motor rating.

Selection Tables Gearmotors

15 kW	Hz		50Hz		60Hz	
	P		4	6	4	6
	n ₁	r/min	1450	980	1750	1165

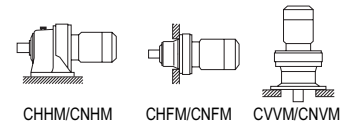

50Hz						60Hz						Nomenclature			Page of Dimension Sheet												
Output Speed n ₂ r/min	Output Torque Tout N·m	kgf·m	Allowable Radial Load Pro		SF	Output Speed n ₂ r/min	Output Torque Tout N·m	kgf·m	Allowable Radial Load Pro		SF	Input Capacity Symbol	Frame Size	Reduction Ratio	CNHM CHHM	CNFM CHFM	CNVM CVVM										
			N	kgf					N	kgf																	
50.0	2720	277	19400	1980	1.16	60.3	2260	230	18400	1870	1.25	20 -	6175	- 29	B-103	B-119	B-138										
			26400	2690	1.30				24900	2540	1.30				6180	- 29	B-104	B-120	B-139								
			26400	2690	1.61				24900	2540	1.61				6185	- 29	B-104	B-120	B-139								
			37400	3810	2.05				35200	3580	2.05				6190	- 29	B-104	B-120	B-139								
			37400	3810	2.52				35200	3580	2.52				6195	- 29	B-104	B-120	B-139								
41.4	3280	335	20400	2080	0.96	50.0	2720	277	19400	1970	1.01	20 -	6175	- 35	B-103	B-119	B-138										
			28100	2860	1.23				26500	2700	1.25				6180	- 35	B-104	B-120	B-139								
			28100	2860	1.51				26500	2700	1.51				6185	- 35	B-104	B-120	B-139								
			39400	4020	1.62				37100	3780	1.62				6190	- 35	B-104	B-120	B-139								
			39400	4020	2.01				37100	3780	2.01				6195	- 35	B-104	B-120	B-139								
33.7	4040	411	29900	3050	1.01	40.7	3340	341	28300	2880	1.01	20 -	6180	- 43	B-104	B-120	B-139										
			29900	3050	1.24				28300	2880	1.25				6185	- 43	B-104	B-120	B-139								
			42300	4310	1.39				39900	4060	1.39				6190	- 43	B-104	B-120	B-139								
			42300	4310	1.81				39900	4060	2.01				6195	- 43	B-104	B-120	B-139								
			77500	7900	2.12				73300	7480	2.12				6205	- 43	B-105	B-121	B-140								
28.4	4790	488	30900	3150	1.01	34.3	3970	404	29200	2980	1.01	20 -	6185	- 51	B-104	B-120	B-139										
			44100	4490	1.21				41500	4230	1.21				6190	- 51	B-104	B-120	B-139								
			44100	4490	1.39				41500	4230	1.39				6195	- 51	B-104	B-120	B-139								
24.6	5540	564	32100	3270	0.80	29.7	4590	468	30400	3100	0.80	20 -	6185	- 59	B-104	B-120	B-139										
			46000	4690	1.02				43400	4430	1.02				6190	- 59	B-104	B-120	B-139								
			46000	4690	1.25				43400	4430	1.25				6195	- 59	B-104	B-120	B-139								
			84100	8570	1.51				79700	8120	1.51				6205	- 59	B-105	B-121	B-140								
			85900	8760	2.26				81300	8290	2.51	6215	- 59	B-105	B-121	B-140											
20.4	6660	679	48600	4960	1.04	24.6	5520	563	45900	4680	1.04	20 -	6195	- 71	B-104	B-120	B-139										
16.7	8170	832	52100	5310	0.91	20.1	6770	690	49200	5010	0.91	20 -	6195	- 87	B-104	B-120	B-139										
			84100	8570	1.06				84100	8570	1.06				6205	- 87	B-105	B-121	B-140								
			96100	9790	1.31				91000	9280	1.43				6215	- 87	B-105	B-121	B-140								
			102000	10400	1.78				96400	9830	1.78				6225	- 87*2	B-106	B-122	B-141								
16.6	8190	835	84100	8570	1.13	19.7	6890	703	84100	8570	1.30	206 -	6205	- 59	B-105	B-121	B-140										
			96200	9800	1.55				91500	9330	1.83				6215	- 59	B-105	B-121	B-140								
			102000	10400	1.94				97000	9890	2.22				6225	- 59	B-106	B-122	B-141								
13.9	6380	650	55800	5690	*1	16.8	6090	621	52400	5340	*1	20 -	6190DB	- 104	B-112	B-128	B-147										
			7350	750	55400				5650	*1	6090				621	52400	5340	*1	6195DB	- 104	B-112	B-128	B-147				
			9250	943	54700				5580	0.80	7660				781	51800	5280	0.80	6195DB	- 104	B-112	B-128	B-147				
12.0	10800	1100	7580	773	59000	6010	*1	14.5	8910	909	7090	723	55700	5680	*1	20 -	6195DB	- 121	B-112	B-128	B-147						
			8560	872	84100	8570	*1				7090	723	84100	8570	*1				6205DB	- 121	B-112	B-129	B-148				
11.3	12100	1230	114000	11600	1.25	13.4	10200	1040	108000	11000	1.48	206 -	6225	- 87	B-106	B-122	B-141										
			142000	14500	1.42				135000	13800	1.60				6235	- 87	B-106	B-122	B-141								
			159000	16200	1.87				151000	15400	2.14				6245	- 87	B-107	B-123	B-142								
			196000	19900	2.57				186000	19000	2.86				6255	- 87	B-107	B-123	B-142								

1. Combinations in **bold** are the recommended models for operations for 10 hours/day with uniform load (service factor is about 1.0 for motor rating at 50Hz).
2. Motor slippage may affect n₁ and n₂. Refer to technical data for details.
3. CNHM, CHHM, CNFM, CHFM, CNVM, and CVVM indicate types. Refer to page B-10 for details.
4. Lubrication method is different for each model. Refer to "Lubrication" section in page F-4~F-5 for details.
5. "6" at the end of "input capacity symbol" indicates models with 6P motor. Other models come with 4P motor.

Selection Tables Gearmotors

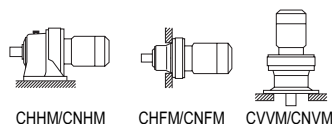

15 kW	Hz		50Hz		60Hz	
	P		4	6	4	6
	n ₁	r/min	1450	980	1750	1165

50Hz						60Hz					Nomenclature			Page of Dimension Sheet				
Output Speed n ₂ r/min	Output Torque Tout		Allowable Radial Load Pro		SF	Output Speed n ₂ r/min	Output Torque Tout		Allowable Radial Load Pro		SF	Input Capacity - Symbol	Frame Size	Reduction Ratio	CNHM	CNFM	CNVM	
	N·m	kgf·m	N	kgf			N·m	kgf·m	N	kgf								CHHM
8.79	9270	945	84100	8570	*1	10.6	9270	945	84100	8570	*1	20 -	6205DB	- 165	B-112	B-129	B-148	
	11700	1190	104000	10600	*1		9670	985	104000	10600	*1	20 -	6215DA	- 165	B-112	B-129	B-148	
			104000	10600	0.80					104000	10600	0.80	20 -	6215DA	- 165	B-112	B-129	B-148
			104000	10600	0.83					104000	10600	1.00	20 -	6215DB	- 165	B-113	B-129	B-149
			122000	12500	0.98					116000	11800	1.19	20 -	6225DB	- 165	B-113	B-130	B-149
			152000	15500	1.34					144000	14700	1.61	20 -	6235DA	- 165	B-114	B-114	B-150
	14700	1500	170000	17400	1.69		12200	1240	1240	161000	16400	1.69	20 -	6245DA	- 165	B-114	B-114	B-150
			170000	17400	1.79					161000	16400	2.16	20 -	6245DB	- 165	B-114	B-114	B-150
			209000	21300	2.12					197000	20100	2.12	20 -	6255DA	- 165	B-115	B-132	B-151
			209000	21300	2.12					197000	20100	2.56	20 -	6255DB	- 165	B-115	B-132	B-151
		254000	25900	2.98	241000	24500				3.38	20 -	6265DA	- 165	B-115	B-132	B-151		
7.44	12200	1240	104000	10600	*1	8.97	11400	1160	104000	10600	*1	20 -	6215DA	- 195	B-112	B-129	B-148	
	12500	1270	129000	13200	*1		11400	1160	122000	12500	*1	20 -	6225DA	- 195	B-113	B-113	B-149	
			128000	13100	0.84					122000	12400	1.01	20 -	6225DB	- 195	B-113	B-130	B-149
			160000	16300	1.13					151000	15400	1.37	20 -	6235DA	- 195	B-114	B-114	B-150
			179000	18200	1.51					169000	17200	1.59	20 -	6245DA	- 195	B-114	B-114	B-150
	17300	1770	179000	18200	1.51		14400	1460	169000	17200	1.83	20 -	6245DB	- 195	B-114	B-114	B-150	
			219000	22300	1.80				207000	21100	2.12	20 -	6255DA	- 195	B-115	B-132	B-151	
			219000	22300	1.80				207000	21100	2.17	20 -	6255DB	- 195	B-115	B-132	B-151	
		267000	27200	2.52	253000	25800			3.04	20 -	6265DA	- 195	B-115	B-132	B-151			
6.28	14800	1510	137000	14000	*1	7.58	13500	1380	130000	13200	*1	20 -	6225DA	- 231	B-113	B-113	B-149	
			171000	17400	0.92					162000	16500	1.11	20 -	6235DA	- 231	B-114	B-114	B-150
			190000	19400	1.26					180000	18400	1.52	20 -	6245DA	- 231	B-114	B-114	B-150
	20500	2090	232000	23700	1.51		17000	1730	220000	22400	1.82	20 -	6255DA	- 231	B-115	B-132	B-151	
			276000	28100	2.24				269000	27400	2.70	20 -	6265DA	- 231	B-115	B-132	B-151	
5.31	18900	1930	179000	18200	*1	6.41	18900	1930	170000	17300	*1	20 -	6235DA	- 273	B-114	B-114	B-150	
			200000	20300	1.06					189000	19300	1.28	20 -	6245DA	- 273	B-114	B-114	B-150
	24300	2470	244000	24900	1.28		20100	2050	231000	23500	1.54	20 -	6255DA	- 273	B-115	B-132	B-151	
			276000	28100	1.90				276000	28100	2.29	20 -	6265DA	- 273	B-115	B-132	B-151	
4.55	18900	1930	179000	18200	*1	5.49	18900	1930	177000	18100	*1	20 -	6235DA	- 319	B-114	B-114	B-150	
			208000	21200	0.91					197000	20100	1.10	20 -	6245DA	- 319	B-114	B-114	B-150
			256000	26100	1.14					243000	24800	1.38	20 -	6255DA	- 319	B-115	B-132	B-151
	28400	2890	276000	28100	1.62		23500	2400	276000	28100	1.96	20 -	6265DA	- 319	B-115	B-132	B-151	
			248000	25300	2.40				248000	25300	2.90	20 -	6275DA	- 319	B-115	-	B-151	
3.85	25800	2630	208000	21200	*1	4.64	25800	2630	207000	21100	*1	20 -	6245DA	- 377	B-114	B-114	B-150	
			258000	26300	0.97					255000	26000	1.17	20 -	6255DA	- 377	B-115	B-132	B-151
	33500	3420	276000	28100	1.37		27800	2830	276000	28100	1.66	20 -	6265DA	- 377	B-115	B-132	B-151	
			248000	25300	2.03				248000	25300	2.46	20 -	6275DA	- 377	B-115	-	B-151	
3.07	25800	2630	208000	21200	*1	3.70	25800	2630	208000	21200	*1	20 -	6245DA	- 473	B-114	B-114	B-150	
	34500	3520	258000	26300	*1		34500	3520	258000	26300	*1	20 -	6255DA	- 473	B-115	B-132	B-151	
			258000	26300	0.82					258000	26300	0.98	20 -	6255DA	- 473	B-115	B-132	B-151
			258000	26300	0.82					258000	26300	0.98	20 -	6255DB	- 473	B-115	B-132	B-151
	42100	4290	276000	28100	1.09		34800	3550	276000	28100	1.32	20 -	6265DA	- 473	B-115	B-132	B-151	
			248000	25300	1.62				248000	25300	1.96	20 -	6275DA	- 473	B-115	-	B-151	
2.59	34500	3520	258000	26300	*1	3.13	34500	3520	258000	26300	*1	20 -	6255DA	- 559	B-115	B-132	B-151	
			276000	28100	0.93					276000	28100	1.12	20 -	6265DA	- 559	B-115	B-132	B-151
	49700	5070	248000	25300	1.37		41200	4200	248000	25300	1.66	20 -	6275DA	- 559	B-115	-	B-151	
2.23	46000	4690	276000	28100	*1	2.70	46000	4690	276000	28100	*1	20 -	6265DA	- 649	B-115	B-132	B-151	
			276000	28100	0.80					276000	28100	0.96	20 -	6265DA	- 649	B-115	B-132	B-151
	57700	5880	248000	25300	1.18		47800	4870	248000	25300	1.43	20 -	6275DA	- 649	B-115	-	B-151	
1.98	46000	4690	276000	28100	*1	2.39	46000	4690	276000	28100	*1	20 -	6265DA	- 731	B-115	B-132	B-151	
	65000	6630	248000	25300	1.05		53900	5490	248000	25300	1.27	20 -	6275DA	- 731	B-115	-	B-151	
1.72	46000	4690	276000	28100	*1	2.08	46000	4690	276000	28100	*1	20 -	6265DA	- 841	B-115	B-132	B-151	
	74800	7620	248000	25300	0.91		62000	6320	248000	25300	1.10	20 -	6275DA	- 841	B-115	-	B-151	
1.45	68200	6950	248000	25300	*1	1.74	68200	6950	248000	25300	*1	20 -	6275DA	- 1003	B-115	-	B-151	
1.16	68200	6950	248000	25300	*1	1.40	68200	6950	248000	25300	*1	20 -	6275DA	- 1247	B-115	-	B-151	

- "*2" indicate models manufactured with reducer and motor separately mounted on a common baseplate (horizontal shaft direction) or on an adaptor (vertical shaft direction). Consult us for details, including dimensions.
- Allowable radial load (Pro) is the value at the midpoint of the slow speed shaft.
- "*3" indicate models with reduction ratios equal to nominal ratio. Refer to Table A-3 "6000SK Series (Actual Reduction Ratio)" on page A-4 for actual reduction ratio. Indicated reduction ratio is the same as actual reduction ratio for other models.
- Maintain torque load during operation within "Output torque" in the table for models with "*" in the SF column. They cannot be operated with 100% motor rating.

Selection Tables Gearmotors

18.5 kW	Hz		50Hz		60Hz	
	P		4	6	4	6
	n ₁	r/min	1450	980	1750	1165

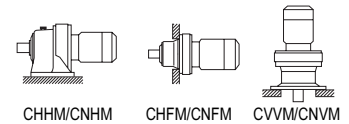

50Hz						60Hz						Nomenclature			Page of Dimension Sheet				
Output Speed n ₂ r/min	Output Torque Tout N·m kgf·m		Allowable Radial Load Pro N kgf		SF	Output Speed n ₂ r/min	Output Torque Tout N·m kgf·m		Allowable Radial Load Pro N kgf		SF	Input Capacity Symbol	Frame Size	Reduction Ratio	CNHM CHHM	CNFM CHFM	CNVM CVVM		
242	695	70.8	10200	1030	1.10	292	575	58.7	9590	978	1.10	25 - 6160	- 6	- 6	B-103	B-119	B-138		
			10200	1030	1.30				9590	978	1.30				B-103	B-119	B-138		
			11500	1180	1.49				10900	1110	1.49				25 - 6170	- 6	B-103	B-119	B-138
			11500	1180	1.63				10900	1110	1.63				25 - 6175	- 6	B-103	B-119	B-138
181	926	94.4	11300	1150	1.06	219	767	78.2	10700	1090	1.06	25 - 6160	- 8	- 8	B-103	B-119	B-138		
			11300	1150	1.30				10700	1090	1.30				25 - 6165	- 8	B-103	B-119	B-138
			12700	1300	1.49				12000	1220	1.49				25 - 6170	- 8	B-103	B-119	B-138
			12700	1300	1.63				12000	1220	1.63				25 - 6175	- 8	B-103	B-119	B-138
132	1270	130	12700	1300	1.06	159	1060	108	12100	1230	1.06	25 - 6160	- 11	- 11	B-103	B-119	B-138		
			12700	1300	1.30				12100	1230	1.30				25 - 6165	- 11	B-103	B-119	B-138
			14600	1490	1.49				13800	1410	1.49				25 - 6170	- 11	B-103	B-119	B-138
			14600	1490	1.63				13800	1410	1.63				25 - 6175	- 11	B-103	B-119	B-138
			19500	1990	1.90				18400	1880	1.90				25 - 6180	- 11	B-104	B-120	B-139
			19500	1990	2.11				18400	1880	2.11				25 - 6185	- 11	B-104	B-120	B-139
112	1500	153	13300	1350	1.06	135	1250	127	12600	1280	1.06	25 - 6160	- 13	- 13	B-103	B-119	B-138		
			13300	1350	1.22				12600	1280	1.22				25 - 6165	- 13	B-103	B-119	B-138
			15200	1550	1.48				14300	1460	1.48				25 - 6170	- 13	B-103	B-119	B-138
			15200	1550	1.63				14300	1460	1.63				25 - 6175	- 13	B-103	B-119	B-138
			20300	2070	1.90				19100	1950	1.90				25 - 6180	- 13	B-104	B-120	B-139
			20300	2070	2.11				19100	1950	2.11				25 - 6185	- 13	B-104	B-120	B-139
96.7	1740	177	14000	1430	1.01	117	1440	147	13300	1350	1.01	25 - 6160	- 15	- 15	B-103	B-119	B-138		
			14000	1430	1.21				13300	1350	1.22				25 - 6165	- 15	B-103	B-119	B-138
			15800	1620	1.38				15000	1530	1.38				25 - 6170	- 15	B-103	B-119	B-138
			15800	1620	1.63				15000	1530	1.63				25 - 6175	- 15	B-103	B-119	B-138
			21400	2180	1.75				20200	2060	1.75				25 - 6180	- 15	B-104	B-120	B-139
			21400	2180	2.11				20200	2060	2.11				25 - 6185	- 15	B-104	B-120	B-139
85.3	1970	201	14400	1460	1.02	103	1630	166	13600	1390	1.02	25 - 6165	- 17	- 17	B-103	B-119	B-138		
			14400	1460	1.06				13600	1390	1.06				25 - 6170	- 17	B-103	B-119	B-138
			16500	1680	1.30				15600	1590	1.30				25 - 6175	- 17	B-103	B-119	B-138
			16500	1680	1.65				15600	1590	1.65				25 - 6180	- 17	B-104	B-120	B-139
			22600	2300	2.06				21300	2170	2.11				25 - 6185	- 17	B-104	B-120	B-139
			31500	3210	2.22				29700	3020	2.22				25 - 6190	- 17	B-104	B-120	B-139
69.0	2430	248	15300	1550	0.86	83.3	2010	205	14500	1480	0.87	25 - 6165	- 21	- 21	B-103	B-119	B-138		
			17700	1800	1.01				16800	1710	1.05				25 - 6170	- 21	B-103	B-119	B-138
			17700	1800	1.28				16800	1710	1.30				25 - 6175	- 21	B-103	B-119	B-138
			24200	2470	1.62				22800	2330	1.62				25 - 6180	- 21	B-104	B-120	B-139
			24200	2470	2.06				22800	2330	2.11				25 - 6185	- 21	B-104	B-120	B-139
			33900	3450	2.22				31900	3250	2.22				25 - 6190	- 21	B-104	B-120	B-139
58.0	2890	295	18200	1860	1.05	70.0	2400	244	17300	1760	1.05	25 - 6175	- 25	- 25	B-103	B-119	B-138		
			25100	2560	1.30				23700	2410	1.30				25 - 6180	- 25	B-104	B-120	B-139
			25100	2560	1.63				23700	2410	1.63				25 - 6185	- 25	B-104	B-120	B-139
			35400	3610	1.90				33300	3400	1.90				25 - 6190	- 25	B-104	B-120	B-139
			35400	3610	2.19				33300	3400	2.19	25 - 6195	- 25	B-104	B-120	B-139			

1. Combinations in **bold** are the recommended models for operations for 10 hours/day with uniform load (service factor is about 1.0 for motor rating at 50Hz).
2. Motor slippage may affect n₁ and n₂. Refer to technical data for details.
3. CNHM, CHHM, CNFM, CHFM, CNVM, and CVVM indicate types. Refer to page B-10 for details.
4. Lubrication method is different for each model. Refer to "Lubrication" section in page F-4~F-5 for details.
5. "6" at the end of "input capacity symbol" indicates models with 6P motor. Other models come with 4P motor.

Selection Tables Gearmotors

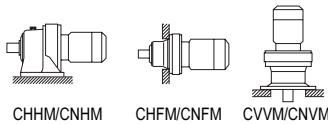

18.5 kW	Hz		50Hz		60Hz	
	P		4	6	4	6
	n ₁	r/min	1450	980	1750	1165



n₁: Motor Speed

50Hz						60Hz						Nomenclature			Page of Dimension Sheet					
Output Speed n ₂ r/min	Output Torque Tout		Allowable Radial Load Pro		SF	Output Speed n ₂ r/min	Output Torque Tout		Allowable Radial Load Pro		SF	Input Capacity Symbol	Frame Size	Reduction Ratio	CNHM	CNFM	CNVM			
	N·m	kgf·m	N	kgf			N·m	kgf·m	N	kgf								CHHM	CHFM	CVVM
50.0	3360	342	19000	1940	0.94	60.3	2780	284	18100	1840	1.02	25 -	6175	- 29	B-103	B-119	B-138			
			26100	2660	1.05				24700	2520	1.05				25 -	6180	- 29	B-104	B-120	B-139
			26100	2660	1.30				24700	2520	1.30				25 -	6185	- 29	B-104	B-120	B-139
			37200	3790	1.66				35000	3570	1.66				25 -	6190	- 29	B-104	B-120	B-139
			37200	3790	2.04				35000	3570	2.04				25 -	6195	- 29	B-104	B-120	B-139
			68700	7000	2.47				65000	6630	2.47	25 -	6205	- 29	B-105	B-121	B-140			
41.4	4050	413	27800	2830	1.00	50.0	3360	342	26300	2680	1.02	25 -	6180	- 35	B-104	B-120	B-139			
			27800	2830	1.22				26300	2680	1.22				25 -	6185	- 35	B-104	B-120	B-139
			39200	3990	1.31				36900	3760	1.31				25 -	6190	- 35	B-104	B-120	B-139
			39200	3990	1.63				36900	3760	1.63				25 -	6195	- 35	B-104	B-120	B-139
33.7	4980	507	29500	3010	1.01	40.7	4120	420	28000	2850	1.02	25 -	6185	- 43	B-104	B-120	B-139			
			42000	4290	1.13				39600	4040	1.13				25 -	6190	- 43	B-104	B-120	B-139
			42000	4290	1.46				39600	4040	1.63				25 -	6195	- 43	B-104	B-120	B-139
			77300	7880	1.72				73200	7460	1.72				25 -	6205	- 43	B-105	B-121	B-140
			78900	8050	2.44				74700	7620	2.44				25 -	6215	- 43	B-105	B-121	B-140
28.4	5900	602	30400	3100	0.82	34.3	4890	499	28900	2940	0.82	25 -	6185	- 51	B-104	B-120	B-139			
			43700	4460	0.98				41300	4210	0.98				25 -	6190	- 51	B-104	B-120	B-139
			43700	4460	1.13				41300	4210	1.13				25 -	6195	- 51	B-104	B-120	B-139
24.6	6830	696	45700	4660	1.02	29.7	5660	577	43100	4400	1.02	25 -	6195	- 59	B-104	B-120	B-139			
			83900	8550	1.22				79400	8100	1.22				25 -	6205	- 59	B-105	B-121	B-140
			85600	8730	1.83				81100	8270	2.04				25 -	6215	- 59	B-105	B-121	B-140
			90800	9250	2.12				86000	8760	2.44				25 -	6225	- 59	B-106	B-122	B-141
22.8	7360	751	47400	4830	1.08	27.1	6190	631	45000	4580	1.24	256 -	6195	- 43	B-104	B-120	B-139			
			88400	9010	1.72				84100	8570	2.04				256 -	6215	- 43	B-105	B-121	B-140
			93700	9550	2.17				89100	9090	2.58				256 -	6225	- 43	B-106	B-122	B-141
20.4	8220	838	48100	4910	0.84	24.6	6810	694	45500	4640	0.84	25 -	6195	- 71	B-104	B-120	B-139			
16.7	10100	1030	95600	9740	1.06	20.1	8340	851	90600	9240	1.16	25 -	6215	- 87	B-105	B-121	B-140			
			101000	10300	1.44				96100	9790	1.44				25 -	6225	- 87	B-106	B-122	B-141
16.6	10100	1030	95700	9760	1.25	19.7	8500	866	91100	9290	1.49	256 -	6215	- 59	B-105	B-121	B-140			
			102000	10300	1.57				96700	9850	1.80				256 -	6225	- 59	B-106	B-122	B-141
			127000	12900	1.87				120000	12300	2.04				256 -	6235	- 59	B-106	B-122	B-142
12.0	13300	1350	104000	10600	0.86	14.5	11000	1120	101000	10300	1.03	25 -	6215DB	- 121	B-113	B-130	B-149			
			113000	11500	1.01				107000	10900	1.22				25 -	6225DB	- 121	B-113	B-130	B-149
			142000	14500	1.37				134000	13700	1.37				25 -	6235DA	- 121	B-114	B-131	B-150
			142000	14500	1.41				134000	13700	1.70				25 -	6235DB	- 121	B-114	B-131	B-150
			158000	16100	1.55				150000	15300	1.87				25 -	6245DB	- 121	B-114	B-131	B-150
			194000	19800	1.72				184000	18700	1.72				25 -	6255DA	- 121	B-115	B-132	B-151
			194000	19800	2.07				184000	18700	2.50				25 -	6255DB	- 121	B-115	B-132	B-151
			237000	24200	2.36				224000	22900	2.74				25 -	6265DA	- 121	B-115	B-132	B-151
11.3	14900	1520	113000	11500	1.01	13.4	12500	1280	108000	11000	1.20	256 -	6225	- 87	B-106	B-122	B-141			
			142000	14400	1.15				135000	13700	1.30				256 -	6235	- 87	B-106	B-122	B-142
			159000	16200	1.52				151000	15400	1.74				256 -	6245	- 87	B-107	B-123	B-142
			195000	19900	2.08				186000	18900	2.32				256 -	6255	- 87	B-107	B-123	B-142
8.79	14500	1480	122000	12500	*1	10.6	15000	1530	115000	11800	*1	25 -	6225DB	- 165	B-113	B-130	B-149			
			121000	12400	0.80				115000	11800	0.97				25 -	6225DB	- 165	B-113	B-130	B-149
			151000	15400	1.08				144000	14600	1.31				25 -	6235DA	- 165	B-114	B-131	B-150
			170000	17300	1.37				161000	16400	1.37				25 -	6245DA	- 165	B-114	B-131	B-150
	18100	1840	1.45	161000	16400	1.75	25 -	6245DB	- 165	B-114	B-131	B-150								
	208000	21200	1.72	197000	20100	1.72	25 -	6255DA	- 165	B-115	B-132	B-151								
	208000	21200	1.72	197000	20100	2.08	25 -	6255DB	- 165	B-115	B-132	B-151								
	254000	25900	2.42	240000	24500	2.74	25 -	6265DA	- 165	B-115	B-132	B-151								

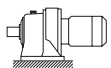
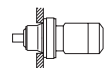

GEARMOTORS
Selection Tables
18.5 kW

- "*2" indicate models manufactured with reducer and motor separately mounted on a common baseplate (horizontal shaft direction) or on an adaptor (vertical shaft direction). Consult us for details, including dimensions.
- Allowable radial load (Pro) is the value at the midpoint of the slow speed shaft.
- "*3" indicate models with reduction ratios equal to nominal ratio. Refer to Table A-3 "6000SK Series (Actual Reduction Ratio)" on page A-4 for actual reduction ratio. Indicated reduction ratio is the same as actual reduction ratio for other models.
- Maintain torque load during operation within "Output torque" in the table for models with "*" in the SF column. They cannot be operated with 100% motor rating.

Selection Tables Gearmotors

18.5 kW		n ₁ : Motor Speed											
		Hz		50Hz		60Hz							
		P		4	6	4	6						
n ₁ r/min		1450		980		1750		1165					
								 CHHM/CNHM  CHFM/CNFM  CVVM/CNVM					
Output Speed n ₂ r/min		Output Torque Tout N·m kgf·m		Allowable Radial Load Pro N kgf		SF		Nomenclature			Page of Dimension Sheet		
50Hz		60Hz		50Hz		60Hz		Input Capacity - Frame Size - Reduction Ratio			CNHM CNFM CNVM CHHM CHFM CVVM		
7.44	21400	2180	159000 178000 178000 218000 218000 267000	16200 18100 18100 22200 22200 27200	0.92 1.23 1.23 1.46 1.46 2.05	8.97	17700	1810	151000 169000 169000 207000 207000 252000	15400 17200 17200 21100 21100 25700	1.11 1.29 1.48 1.72 1.76 2.47	25 - 6235DA - 195 25 - 6245DA - 195 25 - 6245DB - 195 25 - 6255DA - 195 25 - 6255DB - 195 25 - 6265DA - 195	B-114 B-131 B-150 B-114 B-131 B-150 B-114 B-131 B-150 B-115 B-132 B-151 B-115 B-132 B-151 B-115 B-132 B-151
6.28	18900	1930	171000 189000 232000 276000	17400 19300 23600 28100	*1 1.02 1.22 1.82	7.58	18900	1930	162000 180000 219000 269000	16500 18300 22400 27400	*1 1.23 1.48 2.19	25 - 6235DA - 231 25 - 6245DA - 231 25 - 6255DA - 231 25 - 6265DA - 231	B-114 B-131 B-150 B-114 B-131 B-150 B-115 B-132 B-151 B-115 B-132 B-151
5.31	29900	3050	198000 243000 276000	20200 24800 28100	0.86 1.04 1.54	6.41	24800	2530	188000 230000 276000	19200 23500 28100	1.04 1.25 1.85	25 - 6245DA - 273 25 - 6255DA - 273 25 - 6265DA - 273	B-114 B-131 B-150 B-115 B-132 B-151 B-115 B-132 B-151
4.55	25800	2630	208000 255000 276000 248000	21200 26000 28100 25300	*1 0.93 1.31 1.95	5.49	25800	2630	196000 242000 276000 248000	20000 24600 28100 25300	*1 1.12 1.59 2.35	25 - 6245DA - 319 25 - 6255DA - 319 25 - 6265DA - 319 25 - 6275DA - 319	B-114 B-131 B-150 B-115 B-132 B-151 B-115 B-132 B-151 B-115 - B-151
3.85	32500	3310	258000 276000 248000	26300 28100 25300	*1 1.11 1.65	4.64	32500	3310	254000 276000 248000	25900 28100 25300	*1 1.34 1.99	25 - 6255DA - 377 25 - 6265DA - 377 25 - 6275DA - 377	B-115 B-132 B-151 B-115 B-132 B-151 B-115 - B-151
3.07	51900	5290	276000 248000	28100 25300	0.89 1.31	3.70	43000	4380	276000 248000	28100 25300	1.07 1.59	25 - 6265DA - 473 25 - 6275DA - 473	B-115 B-132 B-151 B-115 - B-151
2.59	46000	4690	276000 61300	28100 25300	*1 1.11	3.13	46000	4690	276000 50800	28100 25300	*1 1.34	25 - 6265DA - 559 25 - 6275DA - 559	B-115 B-132 B-151 B-115 - B-151
2.23	71200	7250	248000	25300	0.96	2.70	59000	6010	248000	25300	1.16	25 - 6275DA - 649	B-115 - B-151
1.98	80200	8170	248000	25300	0.85	2.39	66400	6770	248000	25300	1.03	25 - 6275DA - 731	B-115 - B-151
1.72	68200	6950	248000	25300	*1	2.08	68200	6950	248000	25300	*1	25 - 6275DA - 841	B-115 - B-151

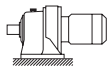
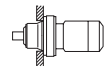
Selection Tables
18.5 kW, 22 kW
GEARMOTORS

22 kW		n ₁ : Motor Speed											
		Hz		50Hz		60Hz							
		P		4	6	4	6						
n ₁ r/min		1450		980		1750		1165					
								 CHHM/CNHM  CHFM/CNFM  CVVM/CNVM					
Output Speed n ₂ r/min		Output Torque Tout N·m kgf·m		Allowable Radial Load Pro N kgf		SF		Nomenclature			Page of Dimension Sheet		
50Hz		60Hz		50Hz		60Hz		Input Capacity - Frame Size - Reduction Ratio			CNHM CNFM CNVM CHHM CHFM CVVM		
242	826	84.2	10100 11500 11500	1020 1170 1170	1.10 1.25 1.37	292	684	69.8	9510 10800 10800	969 1100 1100	1.10 1.25 1.37	30 - 6165 - 6 30 - 6170 - 6 30 - 6175 - 6	B-103 B-119 B-138 B-103 B-119 B-138 B-103 B-119 B-138
181	1100	112	11200 12600 12600	1140 1290 1290	1.10 1.25 1.37	219	912	93.0	10600 11900 11900	1080 1220 1220	1.10 1.25 1.37	30 - 6165 - 8 30 - 6170 - 8 30 - 6175 - 8	B-103 B-119 B-138 B-103 B-119 B-138 B-103 B-119 B-138

1. Combinations in **bold** are the recommended models for operations for 10 hours/day with uniform load (service factor is about 1.0 for motor rating at 50Hz).
2. Motor slippage may affect n₁ and n₂. Refer to technical data for details.
3. CNHM, CHHM, CNFM, CHFM, CNVM, and CVVM indicate types. Refer to page B-10 for details.
4. Lubrication method is different for each model. Refer to "Lubrication" section in page F-4~F-5 for details.
5. "6" at the end of "input capacity symbol" indicates models with 6P motor. Other models come with 4P motor.

Selection Tables Gearmotors

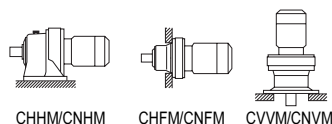

22 kW	Hz		50Hz		60Hz	
	P		4	6	4	6
	n ₁	r/min	1450	980	1750	1165

n₁: Motor Speed

50Hz					60Hz					Nomenclature			Page of Dimension Sheet										
Output Speed n ₂ r/min	Output Torque Tout		Allowable Radial Load Pro		SF	Output Speed n ₂ r/min	Output Torque Tout		Allowable Radial Load Pro		Input Capacity Symbol	Frame Size	Reduction Ratio	CNHM	CNFM	CNVM							
	N·m	kgf·m	N	kgf			N·m	kgf·m	N	kgf							CHHM	CHFM	CVVM				
132	1510	154	12600	1280	1.10	159	1250	128	11900	1220	1.10	30 -	6165	- 11	B-103	B-119	B-138						
			14500	1470	1.25				13700	1390	1.25	30 -	6170	- 11	B-103	B-119	B-138						
			14500	1470	1.37				13700	1390	1.37	30 -	6175	- 11	B-103	B-119	B-138						
			19500	1980	1.60				18300	1870	1.60	30 -	6180	- 11	B-104	B-120	B-139						
			19500	1980	1.77				18300	1870	1.77	30 -	6185	- 11	B-104	B-120	B-139						
			27300	2780	1.86				25700	2620	1.86	30 -	6190	- 11	B-104	B-120	B-139						
			27300	2780	2.19				25700	2620	2.19	30 -	6195	- 11	B-104	B-120	B-139						
52300	5330	2.71	49500	5040	2.71	30 -	6205	- 11	B-105	B-121	B-140												
112	1790	182	13100	1330	1.03	135	1480	151	12400	1270	1.03	30 -	6165	- 13	B-103	B-119	B-138						
			15000	1530	1.24				14200	1450	1.24	30 -	6170	- 13	B-103	B-119	B-138						
			15000	1530	1.37				14200	1450	1.37	30 -	6175	- 13	B-103	B-119	B-138						
			20200	2060	1.60				19100	1940	1.60	30 -	6180	- 13	B-104	B-120	B-139						
			20200	2060	1.77				19100	1940	1.77	30 -	6185	- 13	B-104	B-120	B-139						
			28400	2890	1.86				26700	2730	1.86	30 -	6190	- 13	B-104	B-120	B-139						
			28400	2890	2.19				26700	2730	2.19	30 -	6195	- 13	B-104	B-120	B-139						
96.7	2060	210	13800	1400	1.02	117	1710	174	13100	1340	1.03	30 -	6165	- 15	B-103	B-119	B-138						
			15600	1590	1.16				14800	1510	1.16	30 -	6170	- 15	B-103	B-119	B-138						
			15600	1590	1.37				14800	1510	1.37	30 -	6175	- 15	B-104	B-120	B-139						
			21300	2170	1.47				20100	2050	1.47	30 -	6180	- 15	B-104	B-120	B-139						
			21300	2170	1.77				20100	2050	1.77	30 -	6185	- 15	B-104	B-120	B-139						
			29800	3040	1.86				28100	2860	1.86	30 -	6190	- 15	B-104	B-120	B-139						
			29800	3040	2.19				28100	2860	2.19	30 -	6195	- 15	B-104	B-120	B-139						
56200	5730	2.71	53200	5420	2.71	30 -	6205	- 15	B-105	B-121	B-140												
85.3	2340	239	14100	1440	0.86	103	1940	198	13400	1370	0.86	30 -	6165	- 17	B-103	B-119	B-138						
			16200	1650	1.10				15400	1570	1.10	30 -	6175	- 17	B-103	B-119	B-138						
			22400	2280	1.39				21200	2160	1.39	30 -	6180	- 17	B-104	B-120	B-139						
			22400	2280	1.74				21200	2160	1.77	30 -	6185	- 17	B-104	B-120	B-139						
			31400	3200	1.86				29600	3010	1.86	30 -	6190	- 17	B-104	B-120	B-139						
			31400	3200	2.19				29600	3010	2.19	30 -	6195	- 17	B-104	B-120	B-139						
			69.0	2890	295				17500	1780	1.07	83.3	2400	244	16600	1690	1.10	30 -	6175	- 21	B-103	B-119	B-138
24000	2450	1.36				22700	2310	1.36	30 -	6180	- 21				B-104	B-120	B-139						
24000	2450	1.73				22700	2310	1.77	30 -	6185	- 21				B-104	B-120	B-139						
33700	3440	1.86				31800	3240	1.86	30 -	6190	- 21				B-104	B-120	B-139						
33700	3440	2.19				31800	3240	2.19	30 -	6195	- 21				B-104	B-120	B-139						
62900	6410	2.69				59500	6070	2.69	30 -	6205	- 21				B-105	B-121	B-140						
58.0	3440	351				17900	1830	0.89	70.0	2850	291				17000	1740	0.89	30 -	6175	- 25	B-103	B-119	B-138
			24900	2530	1.10	23500	2400	1.10				30 -	6180	- 25	B-104	B-120	B-139						
			24900	2530	1.37	23500	2400	1.37				30 -	6185	- 25	B-104	B-120	B-139						
			35300	3590	1.60	33200	3390	1.60				30 -	6190	- 25	B-104	B-120	B-139						
			35300	3590	1.84	33200	3390	1.84				30 -	6195	- 25	B-104	B-120	B-139						
			50.0	3990	407	25900	2640	1.10				60.3	3310	337	24500	2500	1.10	30 -	6185	- 29	B-104	B-120	B-139
						37000	3770	1.40							34900	3560	1.40	30 -	6190	- 29	B-104	B-120	B-139
37000	3770	1.72				34900	3560	1.72	30 -	6195	- 29				B-104	B-120	B-139						
68500	6990	2.08				64900	6610	2.08	30 -	6205	- 29				B-105	B-121	B-140						
70000	7130	2.66				66200	6750	2.66	30 -	6215	- 29				B-105	B-121	B-140						
41.4	4820	491				27500	2810	1.03	50.0	3990	407				26000	2650	1.03	30 -	6185	- 35	B-104	B-120	B-139
						39000	3970	1.10							36700	3750	1.10	30 -	6190	- 35	B-104	B-120	B-139
			39000	3970	1.37	36700	3750	1.37				30 -	6195	- 35	B-104	B-120	B-139						
			33.7	5920	603	29100	2970	0.85				40.7	4900	500	27600	2820	0.85	30 -	6185	- 43	B-104	B-120	B-139
						41800	4260	0.95							39400	4020	0.95	30 -	6190	- 43	B-104	B-120	B-139
						41800	4260	1.23							39400	4020	1.37	30 -	6195	- 43	B-104	B-120	B-139
						77100	7860	1.45							73000	7440	1.45	30 -	6205	- 43	B-105	B-121	B-140
78700	8020	2.05				74600	7600	2.05	30 -	6215	- 43				B-105	B-121	B-140						
83400	8510	2.57				79000	8050	2.57	30 -	6225	- 43				B-106	B-122	B-141						
28.4	7020	716				43400	4420	0.95	34.3	5820	593				41000	4180	0.95	30 -	6195	- 51	B-104	B-120	B-139

GEARMOTORS
Selection Tables
22 kW

- "*2" indicate models manufactured with reducer and motor separately mounted on a common baseplate (horizontal shaft direction) or on an adaptor (vertical shaft direction). Consult us for details, including dimensions.
- Allowable radial load (Pro) is the value at the midpoint of the slow speed shaft.
- "*3" indicate models with reduction ratios equal to nominal ratio. Refer to Table A-3 "6000SK Series (Actual Reduction Ratio)" on page A-4 for actual reduction ratio. Indicated reduction ratio is the same as actual reduction ratio for other models.
- Maintain torque load during operation within "Output torque" in the table for models with "*"1" in the SF column. They cannot be operated with 100% motor rating.

Selection Tables Gearmotors

22 kW	Hz		50Hz		60Hz	
	P		4	6	4	6
	n ₁	r/min	1450	980	1750	1165

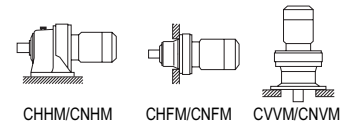

50Hz						60Hz					Nomenclature			Page of Dimension Sheet			
Output Speed n ₂ r/min	Output Torque T _{out} N·m kgf·m		Allowable Radial Load Pro N kgf		SF	Output Speed n ₂ r/min	Output Torque T _{out} N·m kgf·m		Allowable Radial Load Pro N kgf		SF	Input Capacity Symbol	Frame Size	Reduction Ratio	CNHM	CNFM	CNVM
24.6	8120	828	45300	4620	0.85	29.7	6730	686	42800	4360	0.85	30 -	6195	- 59	B-104	B-120	B-139
			83600	8520	1.03				79200	8070	1.03	30 -	6205	- 59	B-105	B-121	B-140
			85300	8690	1.54				80800	8240	1.71	30 -	6215	- 59	B-105	B-121	B-140
			90500	9220	1.79				85700	8740	2.05	30 -	6225	- 59	B-106	B-122	B-141
22.8	8760	893	84100	8570	1.06	27.1	7370	751	82100	8370	1.26	306 -	6205	- 43	B-105	B-121	B-140
			88000	8970	1.45				83800	8540	1.72	306 -	6215	- 43	B-105	B-121	B-140
			93400	9520	1.83				88900	9060	2.17	306 -	6225	- 43	B-106	B-122	B-141
			101000	10300	1.21				95700	9760	1.21	30 -	6225	- 87	B-106	B-122	B-141
16.7	12000	1220	95200	9710	1.05	20.1	9920	1010	90700	9250	1.25	306 -	6215	- 59	B-105	B-121	B-140
			101000	10300	1.32				96300	9810	1.51	306 -	6225	- 59	B-106	B-122	B-141
			141000	14400	2.15				134000	13700	2.55	306 -	6245	- 59	B-107	B-123	B-142
			101000	10300	1.21				95700	9760	1.21	30 -	6225	- 87	B-106	B-122	B-141
16.6	12000	1220	95200	9710	1.05	19.7	10100	1030	90700	9250	1.25	306 -	6215	- 59	B-105	B-121	B-140
			101000	10300	1.32				96300	9810	1.51	306 -	6225	- 59	B-106	B-122	B-141
			141000	14400	2.15				134000	13700	2.55	306 -	6245	- 59	B-107	B-123	B-142
			101000	10300	1.21				95700	9760	1.21	30 -	6225	- 87	B-106	B-122	B-141
			114000	11600	*1				104000	10600	*1	30 -	6215DB	- 121	B-113	B-130	B-149
			112000	11400	0.85				106000	10900	1.03	30 -	6225DB	- 121	B-113	B-130	B-149
			141000	14400	1.15				134000	13700	1.15	30 -	6235DA	- 121	B-114	B-131	B-150
			141000	14400	1.19				134000	13700	1.43	30 -	6235DB	- 121	B-114	B-131	B-150
12.0	15800	1610	157000	16000	1.30	14.5	13100	1330	149000	15200	1.57	30 -	6245DB	- 121	B-114	B-131	B-150
			193000	19700	1.45				183000	18700	1.45	30 -	6255DA	- 121	B-115	B-132	B-151
			193000	19700	1.74				183000	18700	2.10	30 -	6255DB	- 121	B-115	B-132	B-151
			237000	24100	1.99				224000	22800	2.31	30 -	6265DA	- 121	B-115	B-132	B-151
			158000	16100	1.28				150000	15300	1.46	306 -	6245	- 87	B-107	B-123	B-142
			195000	19800	1.75				185000	18900	1.95	306 -	6255	- 87	B-107	B-123	B-142
237000	24200	2.43	226000	23000	2.43	306 -	6265	- 87	B-107	B-123	B-142						
8.79	21500	2190	151000	15400	0.91	10.6	17800	1820	143000	14600	1.10	30 -	6235DA	- 165	B-114	B-131	B-150
			169000	17200	1.15				160000	16300	1.15	30 -	6245DA	- 165	B-114	B-131	B-150
			169000	17200	1.22				160000	16300	1.47	30 -	6245DB	- 165	B-114	B-131	B-150
			207000	21100	1.45				196000	20000	1.45	30 -	6255DA	- 165	B-115	B-132	B-151
			207000	21100	1.45				196000	20000	1.75	30 -	6255DB	- 165	B-115	B-132	B-151
			253000	25800	2.03				240000	24400	2.31	30 -	6265DA	- 165	B-115	B-132	B-151
7.44	19600	2000	159000	16200	*1	8.97	21100	2150	150000	15300	*1	30 -	6235DA	- 195	B-114	B-131	B-150
			177000	18000	1.03				168000	17100	1.08	30 -	6245DA	- 195	B-114	B-131	B-150
			177000	18000	1.03				168000	17100	1.25	30 -	6245DB	- 195	B-114	B-131	B-150
			218000	22200	1.23				206000	21000	1.45	30 -	6255DA	- 195	B-115	B-132	B-151
			218000	22200	1.23				206000	21000	1.48	30 -	6255DB	- 195	B-115	B-132	B-151
			266000	27100	1.72				252000	25700	2.08	30 -	6265DA	- 195	B-115	B-132	B-151
6.28	30100	3070	188000	19200	0.86	7.58	25000	2540	179000	18200	1.03	30 -	6245DA	- 231	B-114	B-131	B-150
			231000	23500	1.03				219000	22300	1.24	30 -	6255DA	- 231	B-115	B-132	B-151
			276000	28100	1.53				268000	27300	1.84	30 -	6265DA	- 231	B-115	B-132	B-151
			188000	19200	0.86				179000	18200	1.03	30 -	6245DA	- 231	B-114	B-131	B-150
5.31	25800	2630	199000	20300	*1	6.41	25800	2630	188000	19200	*1	30 -	6245DA	- 273	B-114	B-131	B-150
			242000	24700	0.87				229000	23400	1.05	30 -	6255DA	- 273	B-115	B-132	B-151
			276000	28100	1.29				276000	28100	1.56	30 -	6265DA	- 273	B-115	B-132	B-151
4.55	32500	3310	255000	26000	*1	5.49	32500	3310	241000	24600	*1	30 -	6255DA	- 319	B-115	B-132	B-151
			276000	28100	1.11				276000	28100	1.33	30 -	6265DA	- 319	B-115	B-132	B-151
			248000	25300	1.64				248000	25300	1.98	30 -	6275DA	- 319	B-115	-	B-151
3.85	49200	5010	276000	28100	0.94	4.64	40700	4150	276000	28100	1.13	30 -	6265DA	- 377	B-115	B-132	B-151
			248000	25300	1.39				248000	25300	1.67	30 -	6275DA	- 377	B-115	-	B-151
3.07	46000	4690	276000	28100	*1	3.70	46000	4690	276000	28100	*1	30 -	6265DA	- 473	B-115	B-132	B-151
			248000	25300	1.11				51100	5210	1.33	30 -	6275DA	- 473	B-115	-	B-151
2.59	72900	7430	248000	25300	0.94	3.13	60400	6160	248000	25300	1.13	30 -	6275DA	- 559	B-115	-	B-151
			248000	25300	0.94				68200	6950	1.13	30 -	6275DA	- 559	B-115	-	B-151
2.23	68200	6950	248000	25300	*1	2.70	68200	6950	248000	25300	*1	30 -	6275DA	- 649	B-115	-	B-151
			248000	25300	0.81				70100	7150	0.97	30 -	6275DA	- 649	B-115	-	B-151
1.98	68200	6950	248000	25300	*1	2.39	68200	6950	248000	25300	*1	30 -	6275DA	- 731	B-115	-	B-151

1. Combinations in **bold** are the recommended models for operations for 10 hours/day with uniform load (service factor is about 1.0 for motor rating at 50Hz).
2. Motor slippage may affect n₁ and n₂. Refer to technical data for details.
3. CNHM, CHHM, CNFM, CHFM, CNVM, and CVVM indicate types. Refer to page B-10 for details.
4. Lubrication method is different for each model. Refer to "Lubrication" section in page F-4~F-5 for details.
5. "6" at the end of "input capacity symbol" indicates models with 6P motor. Other models come with 4P motor.

Selection Tables Gearmotors

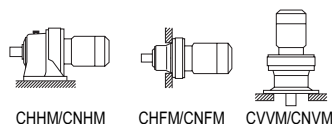

30 kW	Hz		50Hz		60Hz	
	P		4	6	4	6
	n ₁	r/min	1450	980	1750	1165

n₁: Motor Speed

50Hz						60Hz						Nomenclature			Page of Dimension Sheet		
Output Speed n ₂ r/min	Output Torque T _{out} N·m kgf·m		Allowable Radial Load Pro N kgf		SF	Output Speed n ₂ r/min	Output Torque T _{out} N·m kgf·m		Allowable Radial Load Pro N kgf		SF	Input Capacity Symbol	Frame Size	Reduction Ratio	CNHM CHHM	CNFM CHF	CNVM CVVM
242	1130	115	11300	1150	1.00	292	933	95.1	10700	1090	1.00	40 -	6175	- 6	B-103	B-119	B-138
181	1500	153	12400	1260	1.00	219	1240	127	11700	1200	1.00	40 -	6175	- 8	B-103	B-119	B-138
132	2060	210	14100	1440	1.00	159	1710	174	13400	1370	1.00	40 -	6175	- 11	B-103	B-119	B-138
			19200	1960	1.17				18200	1850	1.17	40 -	6180	- 11	B-104	B-120	B-139
			19200	1960	1.30				18200	1850	1.30	40 -	6185	- 11	B-104	B-120	B-139
			27100	2760	1.37				25500	2600	1.37	40 -	6190	- 11	B-104	B-120	B-139
			27100	2760	1.60				25500	2600	1.60	40 -	6195	- 11	B-104	B-120	B-139
			52200	5320	1.99				49400	5030	1.99	40 -	6205	- 11	B-105	B-121	B-140
52900	5390	2.51	50000	5100	2.51	40 -	6215	- 11	B-105	B-121	B-140						
112	2440	249	14600	1490	1.00	135	2020	206	13900	1420	1.00	40 -	6175	- 13	B-103	B-119	B-138
			19900	2030	1.17				18800	1920	1.17	40 -	6180	- 13	B-104	B-120	B-139
			19900	2030	1.30				18800	1920	1.30	40 -	6185	- 13	B-104	B-120	B-139
			28200	2870	1.37				26500	2710	1.37	40 -	6190	- 13	B-104	B-120	B-139
28200	2870	1.60	26500	2710	1.60	40 -	6195	- 13	B-104	B-120	B-139						
96.7	2820	287	15100	1540	1.00	117	2330	238	14400	1470	1.00	40 -	6175	- 15	B-103	B-119	B-138
			20900	2130	1.08				19800	2020	1.08	40 -	6180	- 15	B-104	B-120	B-139
			20900	2130	1.30				19800	2020	1.30	40 -	6185	- 15	B-104	B-120	B-139
			29500	3010	1.37				27800	2840	1.37	40 -	6190	- 15	B-104	B-120	B-139
			29500	3010	1.60				27800	2840	1.60	40 -	6195	- 15	B-104	B-120	B-139
			56000	5710	1.99				53000	5410	1.99	40 -	6205	- 15	B-105	B-121	B-140
56800	5790	2.51	53800	5480	2.51	40 -	6215	- 15	B-105	B-121	B-140						
85.3	3190	325	15700	1600	0.80	103	2640	270	14900	1520	0.80	40 -	6175	- 17	B-103	B-119	B-138
			22000	2240	1.02				20800	2120	1.02	40 -	6180	- 17	B-104	B-120	B-139
			22000	2240	1.27				20800	2120	1.30	40 -	6185	- 17	B-104	B-120	B-139
			31100	3170	1.37				29300	2990	1.37	40 -	6190	- 17	B-104	B-120	B-139
31100	3170	1.60	29300	2990	1.60	40 -	6195	- 17	B-104	B-120	B-139						
69.0	3940	402	23600	2410	1.00	83.3	3270	333	22400	2280	1.00	40 -	6180	- 21	B-104	B-120	B-139
			23600	2410	1.27				22400	2280	1.30	40 -	6185	- 21	B-104	B-120	B-139
			33500	3410	1.37				31500	3220	1.37	40 -	6190	- 21	B-104	B-120	B-139
			33500	3410	1.60				31500	3220	1.60	40 -	6195	- 21	B-104	B-120	B-139
			62700	6390	1.97				59300	6050	1.97	40 -	6205	- 21	B-105	B-121	B-140
			64100	6530	2.51				60700	6180	2.51	40 -	6215	- 21	B-105	B-121	B-140
58.0	4690	478	24400	2490	1.00	70.0	3890	396	23100	2360	1.00	40 -	6185	- 25	B-104	B-120	B-139
			34900	3560	1.17				32900	3360	1.17	40 -	6190	- 25	B-104	B-120	B-139
			34900	3560	1.35				32900	3360	1.35	40 -	6195	- 25	B-104	B-120	B-139
50.0	5440	555	25300	2580	0.80	60.3	4510	460	24000	2450	0.80	40 -	6185	- 29	B-104	B-120	B-139
			36600	3730	1.02				34500	3520	1.02	40 -	6190	- 29	B-104	B-120	B-139
			36600	3730	1.26				34500	3520	1.26	40 -	6195	- 29	B-104	B-120	B-139
			68200	6950	1.52				64600	6590	1.52	40 -	6205	- 29	B-105	B-121	B-140
			69600	7090	1.95				65900	6720	1.95	40 -	6215	- 29	B-105	B-121	B-140
			73700	7520	2.51				69800	7120	2.51	40 -	6225	- 29	B-106	B-122	B-141
46.7	5830	595	37700	3850	1.09	55.5	4910	500	35800	3650	1.30	406 -	6190	- 21	B-104	B-120	B-139
			37700	3850	1.36				35800	3650	1.60	406 -	6195	- 21	B-104	B-120	B-139
			71700	7310	2.14				68200	6960	2.51	406 -	6215	- 21	B-105	B-121	B-140
41.4	6570	670	38400	3920	1.00	50.0	5440	555	36300	3700	1.00	40 -	6195	- 35	B-104	B-120	B-139
33.8	8050	821	76300	7770	1.15	40.2	6780	691	72600	7400	1.32	406 -	6205	- 29	B-105	B-121	B-140
			77800	7930	1.57				74100	7550	1.87	406 -	6215	- 29	B-105	B-121	B-140
			82500	8410	1.87				78500	8000	2.22	406 -	6225	- 29	B-106	B-122	B-141
33.7	8070	823	41100	4190	0.90	40.7	6690	682	38900	3970	1.00	40 -	6195	- 43	B-104	B-120	B-139
			76600	7810	1.06				72600	7400	1.06	40 -	6205	- 43	B-105	B-121	B-140
			78200	7970	1.51				74100	7560	1.51	40 -	6215	- 43	B-105	B-121	B-140
			83000	8460	1.88				78600	8010	1.88	40 -	6225	- 43	B-106	B-122	B-141
24.6	11100	1130	84600	8620	1.13	29.7	9180	935	80300	8180	1.26	40 -	6215	- 59	B-105	B-121	B-140
			89800	9150	1.31				85200	8680	1.51	40 -	6225	- 59	B-106	B-122	B-141
22.8	11900	1220	87200	8890	1.06	27.1	10000	1020	83100	8480	1.26	406 -	6215	- 43	B-105	B-121	B-140
			92600	9440	1.34				88300	9000	1.59	406 -	6225	- 43	B-106	B-122	B-141

- "*2" indicate models manufactured with reducer and motor separately mounted on a common baseplate (horizontal shaft direction) or on an adaptor (vertical shaft direction). Consult us for details, including dimensions.
- Allowable radial load (Pro) is the value at the midpoint of the slow speed shaft.
- "*3" indicate models with reduction ratios equal to nominal ratio. Refer to Table A-3 "6000SK Series (Actual Reduction Ratio)" on page A-4 for actual reduction ratio. Indicated reduction ratio is the same as actual reduction ratio for other models.
- Maintain torque load during operation within "Output torque" in the table for models with "*"1" in the SF column. They cannot be operated with 100% motor rating.

Selection Tables Gearmotors

30 kW	Hz		50Hz		60Hz	
	P		4	6	4	6
	n ₁	r/min	1450	980	1750	1165

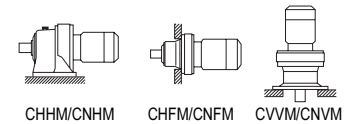

50Hz						60Hz					Nomenclature			Page of Dimension Sheet					
Output Speed n ₂	Output Torque Tout		Allowable Radial Load Pro		SF	Output Speed n ₂	Output Torque Tout		Allowable Radial Load Pro		SF	Input Capacity Symbol	Frame Size	Reduction Ratio	CNHM	CNFM	CNVM		
r/min	N·m	kgf·m	N	kgf		r/min	N·m	kgf·m	N	kgf					CHHM	CHFM	CVVM		
16.6	16400	1670	129000	13200	2.16	19.7	13800	1410	123000	12500	2.51	406 -	6245	- 43	B-107	B-123	B-142		
			125000	12800	1.15				119000	12200	1.26	406 -	6235	- 59	B-106	B-122	B-141		
			140000	14300	1.57				134000	13600	1.87	406 -	6245	- 59	B-107	B-123	B-142		
			173000	17600	1.89				164000	16800	2.16	406 -	6255	- 59	B-107	B-123	B-142		
12.0	21500	2190	13500	1370	113000	11500	*1	13500	1370	106000	10800	*1	40 -	6225DB	- 121	B-113	B-130	B-149	
					140000	14300	0.87			133000	13500	1.05	40 -	6235DB	- 121	B-114	B-131	B-150	
					156000	15900	0.95	14.5	17800	1820	148000	15100	1.15	40 -	6245DB	- 121	B-114	B-131	B-150
					192000	19600	1.06	182000			18600	1.06	40 -	6255DA	- 121	B-115	B-132	B-151	
					192000	19600	1.28	182000			18600	1.54	40 -	6255DB	- 121	B-115	B-132	B-151	
		236000	24000	1.46	223000	22700	1.69	40 -	6265DA	- 121	B-115	B-132	B-151						
11.3	24200	2460	193000	19700	1.28	13.4	20300	2070	184000	18800	1.43	406 -	6255	- 87	B-107	B-123	B-142		
			236000	24100	1.78				225000	22900	1.78	406 -	6265	- 87	B-107	B-123	B-142		
8.79	29300	2990	19600	2000	151000	15400	*1	19600	2000	143000	14500	*1	40 -	6235DB	- 165	B-114	B-131	B-150	
					167000	17000	0.89			159000	16200	1.08	40 -	6245DB	- 165	B-114	B-131	B-150	
					206000	21000	1.06	10.6	24300	2480	195000	19900	1.06	40 -	6255DA	- 165	B-115	B-132	B-151
					206000	21000	1.06	195000			19900	1.28	40 -	6255DB	- 165	B-115	B-132	B-151	
		252000	25700	1.49	239000	24300	1.69	40 -	6265DA	- 165	B-115	B-132	B-151						
7.44	34700	3530	26200	2680	177000	18000	*1	26200	2680	167000	17000	*1	40 -	6245DB	- 195	B-114	B-131	B-150	
					216000	22000	0.90			205000	20900	1.06	40 -	6255DA	- 195	B-115	B-132	B-151	
					216000	22000	0.90	8.97	28700	2930	205000	20900	1.08	40 -	6255DB	- 195	B-115	B-132	B-151
					265000	27000	1.26	251000			25600	1.52	40 -	6265DA	- 195	B-115	B-132	B-151	
6.28	31000	3160	25800	2630	189000	19300	*1	25800	2630	179000	18200	*1	40 -	6245DB	- 231	B-114	B-131	B-150	
			31000	3160	231000	23500	*1	7.58	31000	3160	218000	22200	*1	40 -	6255DA	- 231	B-115	B-132	B-151
			41100	4190	276000	28100	1.12	34000			3470	267000	27200	1.35	40 -	6265DA	- 231	B-115	B-132
5.31	31000	3160	31000	3160	243000	24700	*1	6.41	31000	3160	229000	23400	*1	40 -	6255DA	- 273	B-115	B-132	B-151
			48500	4950	276000	28100	0.95	40200			4100	276000	28100	1.14	40 -	6265DA	- 273	B-115	B-132
4.55	46000	4690	46000	4690	276000	28100	*1	5.49	46000	4690	276000	28100	*1	40 -	6265DA	- 319	B-115	B-132	B-151
			56700	5780	276000	28100	0.81	276000			28100	0.98	40 -	6265DA	- 319	B-115	B-132	B-151	
			248000	25300	1.20	248000	25300	1.45	40 -	6275DA	- 319	B-115	-	B-151					
3.85	46000	4690	46000	4690	276000	28100	*1	4.64	46000	4690	276000	28100	*1	40 -	6265DA	- 377	B-115	B-132	B-151
			67000	6830	248000	25300	1.02	55500			5660	248000	25300	1.23	40 -	6275DA	- 377	B-115	-
3.07	68200	6950	68200	6950	248000	25300	*1	3.70	68200	6950	248000	25300	*1	40 -	6275DA	- 473	B-115	-	B-151
			84100	8570	248000	25300	0.81	69700			7100	248000	25300	0.98	40 -	6275DA	- 473	B-115	-
2.59	68200	6950	248000	25300	*1	3.13	68200	6950	248000	25300	*1	40 -	6275DA	- 559	B-115	-	B-151		

1. Combinations in **bold** are the recommended models for operations for 10 hours/day with uniform load (service factor is about 1.0 for motor rating at 50Hz).
2. Motor slippage may affect n₁ and n₂. Refer to technical data for details.
3. CNHM, CHHM, CNFM, CHFM, CNVM, and CVVM indicate types. Refer to page B-10 for details.
4. Lubrication method is different for each model. Refer to "Lubrication" section in page F-4~F-5 for details.
5. "6" at the end of "input capacity symbol" indicates models with 6P motor. Other models come with 4P motor.

Selection Tables Gearmotors

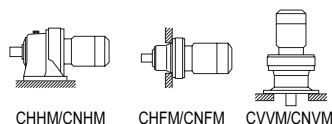

37 kW	Hz		50Hz		60Hz	
	P		4	6	4	6
	n ₁	r/min	1450	980	1750	1165

n₁: Motor Speed

50Hz						60Hz						Nomenclature			Page of Dimension Sheet					
Output Speed n ₂ r/min	Output Torque Tout		Allowable Radial Load Pro		SF	Output Speed n ₂ r/min	Output Torque Tout		Allowable Radial Load Pro		SF	Input Capacity Symbol	Frame Size	Reduction Ratio	CNHM	CNFM	CNVM			
	N·m	kgf·m	N	kgf			N·m	kgf·m	N	kgf								CHHM	CHFM	CVVM
132	2550	260	1900	1940	1.05	159	2110	215	18000	1830	1.05	50 -	6185	- 11	B-104	B-120	B-139			
			27000	2750	1.11				25400	2590	1.11				50 -	6190	- 11	B-104	B-120	B-139
			27000	2750	1.30				25400	2590	1.30				50 -	6195	- 11	B-104	B-120	B-139
			52000	5310	1.61				49300	5020	1.61				50 -	6205	- 11	B-105	B-121	B-140
			52700	5380	2.04				49900	5090	2.04				50 -	6215	- 11	B-105	B-121	B-140
			56000	5700	2.69				53000	5400	2.69				50 -	6225	- 11	B-106	B-122	B-141
112	3010	307	19700	2010	1.05	135	2490	254	18600	1900	1.05	50 -	6185	- 13	B-104	B-120	B-139			
			28000	2850	1.11				26400	2690	1.11				50 -	6190	- 13	B-104	B-120	B-139
			28000	2850	1.30				26400	2690	1.30				50 -	6195	- 13	B-104	B-120	B-139
			20600	2100	1.05				19500	1990	1.05				50 -	6185	- 15	B-104	B-120	B-139
96.7	3470	354	29300	2990	1.11	117	2880	293	27700	2820	1.11	50 -	6190	- 15	B-104	B-120	B-139			
			29300	2990	1.30				27700	2820	1.30				50 -	6195	- 15	B-104	B-120	B-139
			55900	5700	1.61				52900	5390	1.61				50 -	6205	- 15	B-105	B-121	B-140
			56600	5770	2.04				53600	5470	2.04				50 -	6215	- 15	B-105	B-121	B-140
			60400	6160	2.69				57200	5830	2.69				50 -	6225	- 15	B-106	B-122	B-141
			21600	2210	1.03				20500	2090	1.05				50 -	6185	- 17	B-104	B-120	B-139
30900	3150	1.11	29100	2970	1.11	50 -	6190	- 17	B-104	B-120	B-139									
30900	3150	1.30	29100	2970	1.30	50 -	6195	- 17	B-104	B-120	B-139									
23300	2370	1.03	22100	2250	1.05	50 -	6185	- 21	B-104	B-120	B-139									
33200	3380	1.11	31300	3190	1.11	50 -	6190	- 21	B-104	B-120	B-139									
33200	3380	1.30	31300	3190	1.30	50 -	6195	- 21	B-104	B-120	B-139									
69.0	4860	496	62500	6370	1.60	83.3	4030	411	59200	6030	1.60	50 -	6205	- 21	B-105	B-121	B-140			
			63800	6510	2.04				60500	6170	2.04				50 -	6215	- 21	B-105	B-121	B-140
			67500	6880	2.55				63900	6510	2.55				50 -	6225	- 21	B-106	B-122	B-141
			32900	3360	1.11				31300	3190	1.11				506 -	6190	- 15	B-104	B-120	B-139
65.3	5140	524	32900	3360	1.30	77.7	4320	441	31300	3190	1.30	506 -	6195	- 15	B-104	B-120	B-139			
			62600	6380	1.61				59500	6070	1.61				506 -	6205	- 15	B-105	B-121	B-140
			63400	6460	2.04				60300	6150	2.04				506 -	6215	- 15	B-105	B-121	B-140
			23900	2440	0.81				22700	2320	0.81				50 -	6185	- 25	B-104	B-120	B-139
58.0	5790	590	34600	3530	0.95	70.0	4800	489	32700	3330	0.95	50 -	6190	- 25	B-104	B-120	B-139			
			34600	3530	1.09				32700	3330	1.09				50 -	6195	- 25	B-104	B-120	B-139
			36200	3690	1.02				34200	3490	1.02				50 -	6195	- 29	B-104	B-120	B-139
			67900	6920	1.24				64400	6560	1.24				50 -	6205	- 29	B-105	B-121	B-140
50.0	6710	684	69300	7060	1.58	60.3	5560	567	65700	6700	1.58	50 -	6215	- 29	B-105	B-121	B-140			
			73400	7490	2.04				69600	7090	2.04				50 -	6225	- 29	B-106	B-122	B-141
			37300	3800	1.11				35500	3610	1.30				506 -	6195	- 21	B-104	B-120	B-139
			71400	7280	1.74				68000	6930	2.04				506 -	6215	- 21	B-105	B-121	B-140
41.4	8100	826	75500	7690	2.06	55.5	6050	617	71800	7320	2.45	506 -	6225	- 21	B-106	B-122	B-141			
			38000	3870	0.81				35900	3660	0.81				50 -	6195	- 35	B-104	B-120	B-139
			77300	7880	1.27				73700	7510	1.51				506 -	6215	- 29	B-105	B-121	B-140
33.8	9930	1010	82000	8360	1.51	40.2	8360	852	78100	7970	1.80	506 -	6225	- 29	B-106	B-122	B-141			
			103000	10500	1.90				97900	9980	2.04				506 -	6235	- 29	B-106	B-122	B-141
			77700	7920	1.22				73800	7520	1.22				50 -	6215	- 43	B-105	B-121	B-140
33.7	9950	1010	82500	8410	1.53	40.7	8250	841	78300	7980	1.53	50 -	6225	- 43	B-106	B-122	B-141			
			89200	9090	1.06				84700	8630	1.22				50 -	6225	- 59	B-106	B-122	B-141
24.6	13700	1390	129000	13100	1.75	29.7	11300	1150	122000	12500	2.04	506 -	6245	- 43	B-107	B-123	B-142			
22.8	14700	1500	140000	14200	1.28	27.1	12400	1260	133000	13500	1.52	506 -	6245	- 59	B-107	B-123	B-142			
			172000	17600	1.54				164000	16700	1.75				506 -	6255	- 59	B-107	B-123	B-142
			211000	21500	2.28				201000	20500	2.55				506 -	6265	- 59	B-107	B-123	B-142

GEARMOTORS
Selection Tables
37 kW

- "*2" indicate models manufactured with reducer and motor separately mounted on a common baseplate (horizontal shaft direction) or on an adaptor (vertical shaft direction). Consult us for details, including dimensions.
- Allowable radial load (Pro) is the value at the midpoint of the slow speed shaft.
- "*3" indicate models with reduction ratios equal to nominal ratio. Refer to Table A-3 "6000SK Series (Actual Reduction Ratio)" on page A-4 for actual reduction ratio. Indicated reduction ratio is the same as actual reduction ratio for other models.
- Maintain torque load during operation within "Output torque" in the table for models with "*" in the SF column. They cannot be operated with 100% motor rating.

Selection Tables Gearmotors

37 kW		n ₁ : Motor Speed														
		Hz		50Hz		60Hz										
		P	4	6	4	6										
n ₁	r/min	1450	980	1750	1165											
50Hz		60Hz				Nomenclature			Page of Dimension Sheet							
Output Speed n ₂	Output Torque Tout	Allowable Radial Load Pro		SF	Output Speed n ₂	Output Torque Tout	Allowable Radial Load Pro		SF	Input Capacity Symbol	Frame Size	Reduction Ratio	CNHM	CNFM	CNVM	
r/min	N·m	kgf·m	N	kgf	r/min	N·m	kgf·m	N	kgf				CHHM	CHFM	CVVM	
12.0	18700	1910	141000	14300	14.5	18700	1910	133000	13500	50 -	6235DB	- 121	B-114	B-131	B-150	
	20500	2090	156000	15900		20500	2090	148000	15000	50 -	6245DB	- 121	B-114	B-131	B-150	
	26500	2710	191000	19500		22000	2240	181000	18500	1.25	50 - 6255DB	- 121	B-115	B-132	B-151	
11.3	29800	3040	192000	19600	13.4	25100	2560	183000	18700	506 -	6255	- 87	B-107	B-123	B-142	
			236000	24000		224000	22900	1.44	506 -	6265	- 87	B-107	B-123	B-142		
8.79	26200	2680	168000	17100	10.6	26200	2680	158000	16100	50 -	6245DB	- 165	B-114	B-131	B-150	
	36200	3690	205000	20900		30000	3060	194000	19800	1.04	50 -	6255DB	- 165	B-115	B-132	B-151
7.44	31200	3180	216000	22100	8.97	31200	3180	204000	20800	50 -	6265DA	- 165	B-115	B-132	B-151	
	42800	4360	263000	26800		1.02	35400	3610	250000	25400	1.23	50 - 6265DA	- 195	B-115	B-132	B-151
6.28	50700	5160	276000	28100	7.58	42000	4280	266000	27100	1.10	50 -	6265DA	- 231	B-115	B-132	B-151
5.31	46000	4690	276000	28100	6.41	46000	4690	276000	28100	*1	50 -	6265DA	- 273	B-115	B-132	B-151
4.55	70000	7130	248000	25300	5.49	58000	5910	248000	25300	1.18	50 -	6275DA	- 319	B-115	-	B-151
3.85	68200	6950	248000	25300	4.64	68200	6950	248000	25300	*1	50 -	6275DA	- 377	B-115	-	B-151
	82700	8430	248000	25300		68500	6980	248000	25300	1.00	50 -	6275DA	- 377	B-115	-	B-151

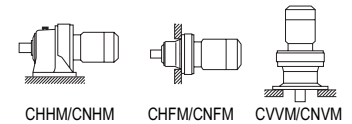

Selection Tables
37 kW, 45 kW
GEARMOTORS

45 kW		n ₁ : Motor Speed															
		Hz		50Hz		60Hz											
		P	4	6	4	6											
n ₁	r/min	1450	980	1750	1165												
50Hz		60Hz				Nomenclature			Page of Dimension Sheet								
Output Speed n ₂	Output Torque Tout	Allowable Radial Load Pro		SF	Output Speed n ₂	Output Torque Tout	Allowable Radial Load Pro		SF	Input Capacity Symbol	Frame Size	Reduction Ratio	CNHM	CNFM	CNVM		
r/min	N·m	kgf·m	N	kgf	r/min	N·m	kgf·m	N	kgf				CHHM	CHFM	CVVM		
132	3100	316	26800	2730	1.07	159	2570	262	25300	2570	1.07	60 -	6195	- 11	B-104	B-120	B-139
			51900	5290	1.33				49200	5010	1.33	60 -	6205	- 11	B-105	B-121	B-140
			52600	5360	1.67				49800	5080	1.67	60 -	6215	- 11	B-105	B-121	B-140
112	3660	373	27700	2830	1.07	135	3030	309	26200	2670	1.07	60 -	6195	- 13	B-104	B-120	B-139
			29000	2960	1.07				27400	2800	1.07	60 -	6195	- 15	B-104	B-120	B-139
			55700	5680	1.33				52800	5380	1.33	60 -	6205	- 15	B-105	B-121	B-140
96.7	4220	431	56500	5750	1.67	117	3500	357	53500	5450	1.67	60 -	6215	- 15	B-105	B-121	B-140
			60200	6140	2.21				57000	5820	2.21	60 -	6225	- 15	B-106	B-122	B-141
			21200	2160	0.85				20200	2060	0.87	60 -	6185	- 17	B-104	B-120	B-139
85.3	4790	488	30600	3120	1.07	103	3970	404	28900	2950	1.07	60 -	6195	- 17	B-104	B-120	B-139
			22800	2330	0.85				21700	2210	0.87	60 -	6185	- 21	B-104	B-120	B-139
			32900	3350	0.91				31100	3170	0.91	60 -	6190	- 21	B-104	B-120	B-139
69.0	5910	603	32900	3350	1.07	83.3	4900	499	31100	3170	1.07	60 -	6195	- 21	B-104	B-120	B-139
			62200	6340	1.32				59000	6010	1.32	60 -	6205	- 21	B-105	B-121	B-140
			63600	6480	1.67				60300	6140	1.67	60 -	6215	- 21	B-105	B-121	B-140
65.3	6250	637	67200	6850	2.09	77.7	5260	536	63700	6490	2.09	60 -	6225	- 21	B-106	B-122	B-141
			62300	6350	1.33				59300	6050	1.33	606 -	6205	- 15	B-105	B-121	B-140
			63100	6430	1.67				60100	6130	1.67	606 -	6215	- 15	B-105	B-121	B-140
58.0	7040	718	67400	6870	2.21	70.0	5830	595	64200	6540	2.21	606 -	6225	- 15	B-106	B-122	B-141
			34200	3490	0.90				32400	3300	0.90	60 -	6195	- 25	B-104	B-120	B-139
50.0	8170	832	35700	3640	0.84	60.3	6770	690	33900	3450	0.84	60 -	6195	- 29	B-104	B-120	B-139
			67600	6890	1.02				64100	6530	1.02	60 -	6205	- 29	B-105	B-121	B-140
			68900	7030	1.30				65400	6660	1.30	60 -	6215	- 29	B-105	B-121	B-140
			73100	7450	1.67				69300	7070	1.67	60 -	6225	- 29	B-106	B-122	B-141

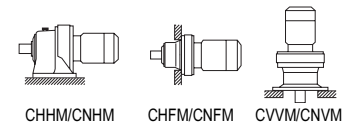

1. Combinations in **bold** are the recommended models for operations for 10 hours/day with uniform load (service factor is about 1.0 for motor rating at 50Hz).
2. Motor slippage may affect n₁ and n₂. Refer to technical data for details.
3. CNHM, CHHM, CNFM, CHFM, CNVM, and CVVM indicate types. Refer to page B-10 for details.
4. Lubrication method is different for each model. Refer to "Lubrication" section in page F-4~F-5 for details.
5. "6" at the end of "input capacity symbol" indicates models with 6P motor. Other models come with 4P motor.

Selection Tables Gearmotors

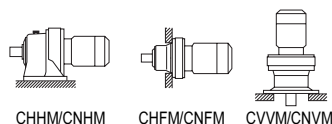

45 kW	Hz		50Hz		60Hz	
	P		4	6	4	6
	n ₁	r/min	1450	980	1750	1165

50Hz						60Hz					Nomenclature			Page of Dimension Sheet			
Output Speed n ₂ r/min	Output Torque Tout N·m kgf·m		Allowable Radial Load Pro N kgf		SF	Output Speed n ₂ r/min	Output Torque Tout N·m kgf·m		Allowable Radial Load Pro N kgf		SF	Input Capacity Symbol	Frame Size	Reduction Ratio	CNHM	CNFM	CNVM
46.7	8750	892	69500	7080	1.06	55.5	7360	750	66200	6750	1.22	606 - 6205	- 21	B-105	B-121	B-140	
			71000	7240	1.43				67700	6900	1.67	606 - 6215	- 21	B-105	B-121	B-140	
			75100	7660	1.69				71500	7290	2.01	606 - 6225	- 21	B-106	B-122	B-141	
			94100	9590	2.16				89500	9130	2.17	606 - 6235	- 21	B-106	B-122	B-141	
33.8	12100	1230	76800	7830	1.05	40.2	10200	1040	73200	7460	1.24	606 - 6215	- 29	B-105	B-121	B-140	
			102000	10400	1.56				97500	9940	1.67	606 - 6235	- 29	B-106	B-122	B-141	
			114000	11700	2.09				109000	11100	2.09	606 - 6245	- 29	B-107	B-123	B-142	
33.7	12100	1230	77200	7870	1.00	40.7	10000	1020	73300	7470	1.00	60 - 6215	- 43	B-105	B-121	B-140	
			82000	8360	1.26				77800	7940	1.26	60 - 6225	- 43	B-106	B-122	B-141	
22.8	17900	1830	114000	11600	1.06	27.1	15100	1540	108000	11100	1.21	606 - 6235	- 43	B-106	B-122	B-141	
			128000	13100	1.44				122000	12400	1.67	606 - 6245	- 43	B-107	B-123	B-142	
			157000	16000	1.73				150000	15300	1.98	606 - 6255	- 43	B-107	B-123	B-142	
			193000	19700	2.51				184000	18700	2.51	606 - 6265	- 43	B-107	B-123	B-142	
16.6	24600	2510	139000	14100	1.05	19.7	20700	2110	132000	13500	1.25	606 - 6245	- 59	B-107	B-123	B-142	
			210000	21400	1.87				200000	20400	2.09	606 - 6265	- 59	B-107	B-123	B-142	
12.0	32300	3290	190000	19400	0.85	14.5	26700	2730	180000	18400	1.03	60 - 6255DB	- 121	B-115	B-132	B-151	
			234000	23800	0.97				222000	22600	1.13	60 - 6265DA	- 121	B-115	B-132	B-151	
11.3	36200	3690	235000	23900	1.19	13.4	30500	3110	223000	22800	1.19	606 - 6265	- 87	B-107	B-123	B-142	
8.79	44000	4490	250000	25500	0.98	10.6	36500	3720	237000	24200	1.13	60 - 6265DA	- 165	B-115	B-132	B-151	
7.44	52000	5300	262000	26700	0.84	8.97	43100	4390	248000	25300	1.01	60 - 6265DA	- 195	B-115	B-132	B-151	
6.28	46000	4690	276000	28100	*1	7.58	46000	4690	265000	27000	*1	60 - 6265DA	- 231	B-115	B-132	B-151	
4.55	85100	8670	68200	6950	248000	25300	*1	68200	6950	248000	25300	*1	60 - 6275DA	- 319	B-115	-	B-151
			85100	8670	248000	25300	0.80	5.49	70500	7190	248000	25300	0.97	60 - 6275DA	- 319	B-115	-

GEARMOTORS

Selection Tables
45 kW, 55 kW

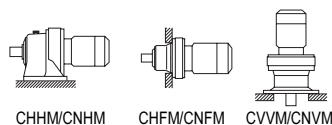



55 kW	Hz		50Hz		60Hz	
	P		4	6	4	6
	n ₁	r/min	1450	980	1750	1165

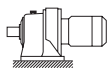
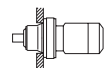

50Hz						60Hz					Nomenclature			Page of Dimension Sheet			
Output Speed n ₂ r/min	Output Torque Tout N·m kgf·m		Allowable Radial Load Pro N kgf		SF	Output Speed n ₂ r/min	Output Torque Tout N·m kgf·m		Allowable Radial Load Pro N kgf		SF	Input Capacity Symbol	Frame Size	Reduction Ratio	CNHM	CNFM	CNVM
132	3790	386	51700	5270	1.09	159	3140	320	49000	5000	1.09	75 - 6205	- 11	B-105	B-121	B-140	
			52400	5340	1.37				49700	5060	1.37	75 - 6215	- 11	B-105	B-121	B-140	
			55600	5670	1.81				52700	5370	1.81	75 - 6225	- 11	B-106	B-122	B-141	
96.7	5160	526	55500	5660	1.09	117	4280	436	52600	5360	1.09	75 - 6205	- 15	B-105	B-121	B-140	
			56200	5730	1.37				53300	5430	1.37	75 - 6215	- 15	B-105	B-121	B-140	
			60000	6120	1.81				56900	5800	1.81	75 - 6225	- 15	B-106	B-122	B-141	
89.1	5600	571	57800	5900	1.09	106	4710	480	55100	5610	1.09	756 - 6205	- 11 *2	-	-	-	
			58600	5970	1.37				55800	5690	1.37	756 - 6215	- 11 *2	-	-	-	
			62200	6340	1.81				59300	6040	1.81	756 - 6225	- 11 *2	-	-	-	
69.0	7230	737	61900	6310	1.08	83.3	5990	610	58700	5980	1.08	75 - 6205	- 21	B-105	B-121	B-140	
			63300	6450	1.37				60000	6120	1.37	75 - 6215	- 21	B-105	B-121	B-140	
			66900	6820	1.71				63400	6470	1.71	75 - 6225	- 21	B-106	B-122	B-141	
65.3	7640	779	62000	6320	1.09	77.7	6420	655	59000	6020	1.09	756 - 6205	- 15 *2	-	-	-	
			62800	6400	1.37				59800	6100	1.37	756 - 6215	- 15 *2	-	-	-	
			67100	6840	1.81				63900	6510	1.81	756 - 6225	- 15 *2	-	-	-	

- "*2" indicate models manufactured with reducer and motor separately mounted on a common baseplate (horizontal shaft direction) or on an adaptor (vertical shaft direction). Consult us for details, including dimensions.
- Allowable radial load (Pro) is the value at the midpoint of the slow speed shaft.
- "*3" indicate models with reduction ratios equal to nominal ratio. Refer to Table A-3 "6000SK Series (Actual Reduction Ratio)" on page A-4 for actual reduction ratio. Indicated reduction ratio is the same as actual reduction ratio for other models.
- Maintain torque load during operation within "Output torque" in the table for models with "*1" in the SF column. They cannot be operated with 100% motor rating.

Selection Tables Gearmotors

55 kW		n ₁ : Motor Speed															
		Hz		50Hz		60Hz											
		P	4	6	4	6											
n ₁	r/min	1450	980	1750	1165												
		  						CHHM/CNHM		CHFM/CNFM		CVVM/CNVM					
		50Hz					60Hz					Nomenclature			Page of Dimension Sheet		
Output Speed n ₂	Output Torque Tout	Allowable Radial Load Pro		SF	Output Speed n ₂	Output Torque Tout	Allowable Radial Load Pro		SF	Input Capacity Symbol	Frame Size	Reduction Ratio	CNHM	CNFM	CNVM		
r/min	N·m	kgf·m	N	kgf	r/min	N·m	kgf·m	N	kgf				CHHM	CHFM	CVVM		
50.0	9980	1020	68500	6980	1.06	60.3	8270	843	65000	6630	1.06	75 - 6215 - 29	B-105	B-121	B-140		
			72700	7410	1.37				69000	7030	1.37	75 - 6225 - 29	B-106	B-122	B-141		
			70500	7190	1.17				67200	6860	1.37	756 - 6215 - 21 *2	-	-	-		
46.7	10700	1090	74700	7610	1.38	55.5	8990	917	71200	7250	1.65	756 - 6225 - 21 *2	-	-	-		
			93700	9550	1.77				89200	9090	1.77	756 - 6235 - 21	B-106	B-122	B-141		
			80900	8240	1.02				77200	7870	1.21	756 - 6225 - 29 *2	-	-	-		
33.8	14800	1510	114000	11600	1.71	40.2	12400	1270	108000	11100	1.71	756 - 6245 - 29	B-107	B-123	B-142		
			141000	14300	2.15				134000	13600	2.15	756 - 6255 - 29	B-107	B-123	B-142		
33.7	14800	1510	81400	8290	1.03	40.7	12300	1250	77300	7880	1.03	75 - 6225 - 43	B-106	B-122	B-141		
			127000	13000	1.18				121000	12400	1.37	756 - 6245 - 43	B-107	B-123	B-142		
22.8	21900	2230	157000	16000	1.42	27.1	18400	1880	149000	15200	1.62	756 - 6255 - 43	B-107	B-123	B-142		
			192000	19600	2.05				183000	18700	2.05	756 - 6265 - 43	B-107	B-123	B-142		
			170000	17400	1.03				162000	16500	1.18	756 - 6255 - 59	B-107	B-123	B-142		
16.6	30000	3060	209000	21400	1.53	19.7	25300	2580	199000	20300	1.71	756 - 6265 - 59	B-107	B-123	B-142		
			248000	25300	2.27				248000	25300	2.40	756 - 6275 - 59 *2	-	-	-		

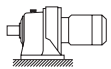
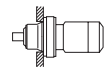
Selection Tables
55 kW, 75 kW
GEARMOTORS

75 kW		n ₁ : Motor Speed															
		Hz		50Hz		60Hz											
		P	4	6	4	6											
n ₁	r/min	1450	980	1750	1165												
		  						CHHM/CNHM		CHFM/CNFM		CVVM/CNVM					
		50Hz					60Hz					Nomenclature			Page of Dimension Sheet		
Output Speed n ₂	Output Torque Tout	Allowable Radial Load Pro		SF	Output Speed n ₂	Output Torque Tout	Allowable Radial Load Pro		SF	Input Capacity Symbol	Frame Size	Reduction Ratio	CNHM	CNFM	CNVM		
r/min	N·m	kgf·m	N	kgf	r/min	N·m	kgf·m	N	kgf				CHHM	CHFM	CVVM		
132	5160	526	55300	5640	1.33	159	4280	436	52400	5340	1.33	100 - 6225 - 11 *2	-	-	-		
96.7	7040	718	59600	6070	1.33	117	5830	595	56500	5760	1.33	100 - 6225 - 15 *2	-	-	-		
			77600	7910	1.51				73900	7530	1.51	1006 - 6235 - 11 *2	-	-	-		
89.1	7640	779	86500	8810	1.76	106	6420	655	82300	8390	1.76	1006 - 6245 - 11 *2	-	-	-		
69.0	9850	1000	66300	6760	1.26	83.3	8170	832	62900	6420	1.26	100 - 6225 - 21 *2	-	-	-		
			82900	8450	1.51				78900	8050	1.51	1006 - 6235 - 15 *2	-	-	-		
65.3	10400	1060	92800	9460	1.76	77.7	8760	893	88300	9000	1.76	1006 - 6245 - 15 *2	-	-	-		
50.0	13600	1390	71800	7320	1.00	60.3	11300	1150	68200	6960	1.00	100 - 6225 - 29 *2	-	-	-		
			92800	9460	1.30				88500	9020	1.30	1006 - 6235 - 21 *2	-	-	-		
46.7	14600	1490	104000	10600	1.60	55.5	12300	1250	98700	10100	1.60	1006 - 6245 - 21 *2	-	-	-		
			127000	12900	2.01				121000	12300	2.01	1006 - 6255 - 21 *2	-	-	-		
			113000	11500	1.26				108000	11000	1.26	1006 - 6245 - 29 *2	-	-	-		
33.8	20100	2050	139000	14200	1.57	40.2	16900	1730	133000	13500	1.57	1006 - 6255 - 29 *2	-	-	-		
			172000	17500	2.12				163000	16600	2.12	1006 - 6265 - 29 *2	-	-	-		
			155000	15800	1.04				148000	15100	1.19	1006 - 6255 - 43 *2	-	-	-		
22.8	29900	3040	191000	19500	1.51	27.1	25100	2560	182000	18600	1.51	1006 - 6265 - 43 *2	-	-	-		
			248000	25300	2.01				248000	25300	2.01	1006 - 6275 - 43 *2	-	-	-		
			208000	21200	1.12				198000	20200	1.26	1006 - 6265 - 59 *2	-	-	-		
16.6	41000	4180	248000	25300	1.67	19.7	34500	3510	248000	25300	1.76	1006 - 6275 - 59 *2	-	-	-		

1. Combinations in **bold** are the recommended models for operations for 10 hours/day with uniform load (service factor is about 1.0 for motor rating at 50Hz).
2. Motor slippage may affect n₁ and n₂. Refer to technical data for details.
3. CNHM, CHHM, CNFM, CHFM, CNVM, and CVVM indicate types. Refer to page B-10 for details.
4. Lubrication method is different for each model. Refer to "Lubrication" section in page F-4~F-5 for details.
5. "6" at the end of "input capacity symbol" indicates models with 6P motor. Other models come with 4P motor.

Selection Tables Gearmotors

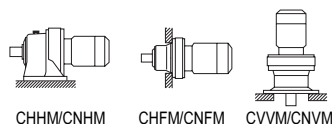

90 kW	Hz		50Hz		60Hz	
	P		4	6	4	6
	n ₁	r/min	1450	980	1750	1165

50Hz						60Hz						Nomenclature			Page of Dimension Sheet					
Output Speed n ₂ r/min	Output Torque Tout		Allowable Radial Load Pro		SF	Output Speed n ₂ r/min	Output Torque Tout		Allowable Radial Load Pro		SF	Input Capacity Symbol	Frame Size	Reduction Ratio	CNHM	CNFM	CNVM			
	N·m	kgf·m	N	kgf			N·m	kgf·m	N	kgf								CHHM	CHF	CVVM
89.1	9170	934	77300	7880	1.26	106	7710	786	73600	7500	1.26	1256-	6235	- 11 *2	-	-	-			
			86100	8780	1.47				82000	8360	1.47				1256-	6245	- 11 *2	-	-	-
			106000	10800	1.68				101000	10300	1.68				1256-	6255	- 11 *2	-	-	-
			130000	13200	1.94				123000	12600	1.94				1256-	6265	- 11 *2	-	-	-
65.3	12500	1270	82400	8400	1.26	77.7	10500	1070	78500	8010	1.26	1256-	6235	- 15 *2	-	-	-			
			92300	9410	1.47				87900	8960	1.47				1256-	6245	- 15 *2	-	-	-
			113000	11600	1.68				108000	11000	1.68				1256-	6255	- 15 *2	-	-	-
			139000	14100	1.94				132000	13400	1.94				1256-	6265	- 15 *2	-	-	-
46.7	17500	1780	92200	9400	1.08	55.5	14700	1500	88000	8970	1.08	1256-	6235	- 21 *2	-	-	-			
			103000	10500	1.33				98200	10000	1.33				1256-	6245	- 21 *2	-	-	-
			126000	12900	1.68				120000	12300	1.68				1256-	6255	- 21 *2	-	-	-
			155000	15800	1.91				147000	15000	1.91				1256-	6265	- 21 *2	-	-	-
33.8	24200	2460	112000	11400	1.05	40.2	20300	2070	107000	10900	1.05	1256-	6245	- 29 *2	-	-	-			
			139000	14100	1.31				132000	13500	1.31				1256-	6255	- 29 *2	-	-	-
			171000	17400	1.77				163000	16600	1.77				1256-	6265	- 29 *2	-	-	-
22.8	35800	3650	190000	19400	1.26	27.1	30100	3070	181000	18500	1.26	1256-	6265	- 43 *2	-	-	-			
			248000	25300	1.68				248000	25300	1.68				1256-	6275	- 43 *2	-	-	-
16.6	49200	5010	248000	25300	1.39	19.7	41400	4220	248000	25300	1.47	1256-	6275	- 59 *2	-	-	-			

GEARMOTORS

Selection Tables
90 kW, 110 kW

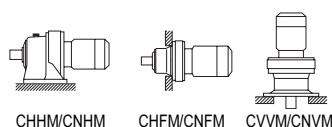

110 kW	Hz		50Hz		60Hz	
	P		4	6	4	6
	n ₁	r/min	1450	980	1750	1165

50Hz						60Hz						Nomenclature			Page of Dimension Sheet		
Output Speed n ₂ r/min	Output Torque Tout		Allowable Radial Load Pro		SF	Output Speed n ₂ r/min	Output Torque Tout		Allowable Radial Load Pro		SF	Input Capacity Symbol	Frame Size	Reduction Ratio	CNHM	CNFM	CNVM
	N·m	kgf·m	N	kgf			N·m	kgf·m	N	kgf							
89.1	11200	1140	85700	8730	1.20	106	9420	961	81600	8320	1.20	1506-	6245	- 11 *2	-	-	-
			105000	10700	1.37				100000	10200	1.37				1506-	6255	- 11 *2
65.3	15300	1560	91700	9350	1.20	77.7	12800	1310	87500	8910	1.20	1506-	6245	- 15 *2	-	-	-
			113000	11500	1.37				108000	11000	1.37				1506-	6255	- 15 *2
46.7	21400	2180	102000	10400	1.09	55.5	18000	1830	97500	9940	1.09	1506-	6245	- 21 *2	-	-	-
			126000	12800	1.37				120000	12200	1.37				1506-	6255	- 21 *2
33.8	29500	3010	138000	14000	1.07	40.2	24800	2530	131000	13400	1.07	1506-	6255	- 29 *2	-	-	-
			170000	17300	1.45				162000	16500	1.45				1506-	6265	- 29 *2
22.8	43800	4460	189000	19300	1.03	27.1	36800	3750	180000	18400	1.03	1506-	6265	- 43 *2	-	-	-

- "*2" indicate models manufactured with reducer and motor separately mounted on a common baseplate (horizontal shaft direction) or on an adaptor (vertical shaft direction). Consult us for details, including dimensions.
- Allowable radial load (Pro) is the value at the midpoint of the slow speed shaft.
- "*3" indicate models with reduction ratios equal to nominal ratio. Refer to Table A-3 "6000SK Series (Actual Reduction Ratio)" on page A-4 for actual reduction ratio. Indicated reduction ratio is the same as actual reduction ratio for other models.
- Maintain torque load during operation within "Output torque" in the table for models with "*" in the SF column. They cannot be operated with 100% motor rating.

Selection Tables Gearmotors

132 kW	Hz		50Hz		60Hz	
	P		4	6	4	6
	n ₁	r/min	1450	980	1750	1165

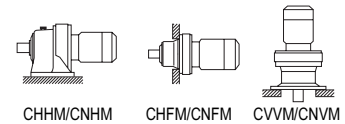

50Hz					60Hz					Nomenclature			Page of Dimension Sheet				
Output Speed n ₂	Output Torque Tout		Allowable Radial Load Pro		SF	Output Speed n ₂	Output Torque Tout		Allowable Radial Load Pro		SF	Input Capacity Symbol	Frame Size	Reduction Ratio	CNHM	CNFM	CNVM
r/min	N·m	kgf·m	N	kgf		r/min	N·m	kgf·m	N	kgf					CHHM	CHFM	CVVM
89.1	13400	1370	105000	10700	1.14	106	11300	1150	99900	10200	1.14	1756-	6255	- 11 *2	-	-	-
			129000	13100	1.33				123000	12500	1.33	1756-	6265	- 11 *2	-	-	-
65.3	18300	1870	112000	11500	1.14	77.7	15400	1570	107000	10900	1.14	1756-	6255	- 15 *2	-	-	-
			138000	14000	1.33				131000	13400	1.33	1756-	6265	- 15 *2	-	-	-
46.7	25700	2620	125000	12700	1.14	55.5	21600	2200	119000	12100	1.14	1756-	6255	- 21 *2	-	-	-
			154000	15700	1.30				146000	14900	1.30	1756-	6265	- 21 *2	-	-	-
33.8	35400	3610	169000	17200	1.20	40.2	29800	3040	161000	16400	1.20	1756-	6265	- 29 *2	-	-	-

GEARMOTORS

Selection Tables
132 kW

- Combinations in **bold** are the recommended models for operations for 10 hours/day with uniform load (service factor is about 1.0 for motor rating at 50Hz).
- Motor slippage may affect n₁ and n₂. Refer to technical data for details.
- CNHM, CHHM, CNFM, CHFM, CNVM, and CVVM indicate types. Refer to page B-10 for details.
- Lubrication method is different for each model. Refer to "Lubrication" section in page F-4~F-5 for details.
- "6" at the end of "input capacity symbol" indicates models with 6P motor. Other models come with 4P motor.
- "*2" indicate models manufactured with reducer and motor separately mounted on a common baseplate (horizontal shaft direction) or on an adaptor (vertical shaft direction). Consult us for details, including dimensions.
- Allowable radial load (Pro) is the value at the midpoint of the slow speed shaft.
- "*3" indicate models with reduction ratios equal to nominal ratio. Refer to Table A-3 "6000SK Series (Actual Reduction Ratio)" on page A-4 for actual reduction ratio. Indicated reduction ratio is the same as actual reduction ratio for other models.
- Maintain torque load during operation within "Output torque" in the table for models with "*1" in the SF column. They cannot be operated with 100% motor rating.

M E M O

GEARMOTORS

Selection
Tables

M E M O

GEARMOTORS

Selection
Tables

B CYCLO® GEARMOTORS

3. Dimension Tables

Dimension Tables Gearmotors (Horizontal Direction, Foot-Mount)

CHHM^{Note 1} - 607□SK to 609□SK

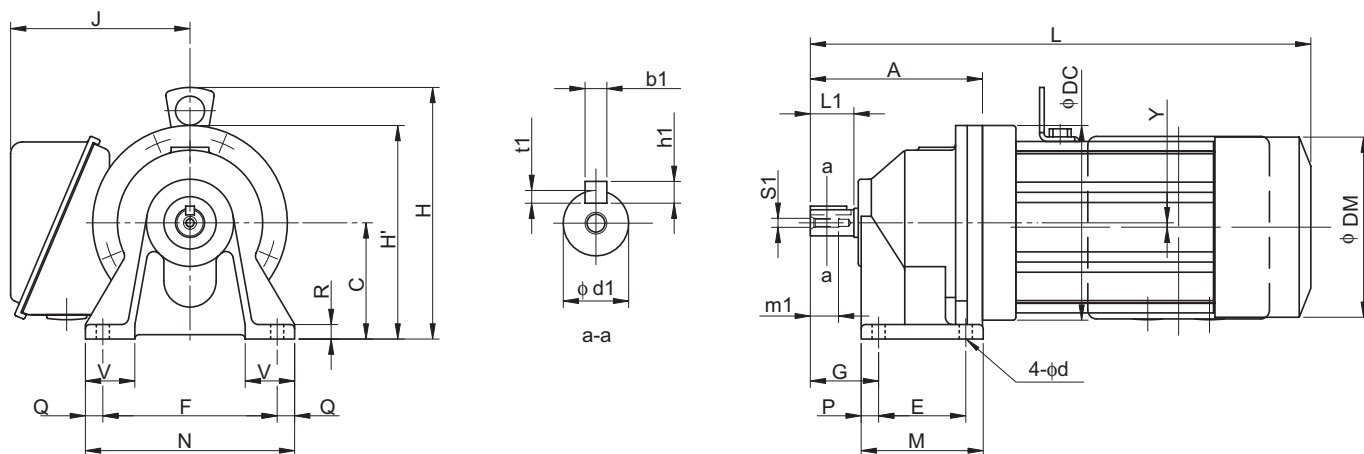

GEARMOTORS
Dimension Tables
CHHM

Frame size <small>Note 4</small>	A	C	DC	E	F	G	M	N	P	Q	R	V	Y	d	Output Shaft <small>Note 2, 3, 6</small>						
															d1	L1	b1	h1	t1	S1	m1
607□SK	119	80	134	60	120	47	84	144	12	12	10	34	0	9	18	30	6	6	3.5	M6	16
608□SK	140	90	150	75	120	52	99	144	12	12	13	37	0	9	22	35	6	6	3.5	M6	16
609□SK	166	100	150	90	150	60	135	180	15	15	12	40	0	11	28	35	8	7	4	M8	20

Model <small>Note 4, 5</small>	Motor		Standard							With Brake					
	kW	P	L	H	H'	J	DM	W(kg)	L	H	H'	J	DM	W(kg)	
CHHM05 - 607□SK - (B) - Ratio	0.4	4	310	-	147	130	124	10	342	-	147	130	124	11	
CHHM08 - 607□SK - (B) - Ratio	0.55	4	351	193	-	140	148	13	394	193	-	140	148	15	
CHHM1 - 607□SK - (B) - Ratio	0.75	4	351	193	-	140	148	13	394	193	-	140	148	15	
CHHM05 - 608□SK - (B) - Ratio	0.4	4	336	-	165	130	124	11	368	-	165	130	124	12	
CHHM08 - 608□SK - (B) - Ratio	0.55	4	377	203	-	140	148	14	420	203	-	140	148	16	
CHHM1 - 608□SK - (B) - Ratio	0.75	4	377	203	-	140	148	14	420	203	-	140	148	16	
CHHM1H - 608□SK - (B) - Ratio	1.1	4	410	210	-	145	160	19	472	210	-	145	160	23	
CHHM2 - 608□SK - (B) - Ratio	1.5	4	410	210	-	145	160	19	472	210	-	145	160	23	
CHHM05 - 609□SK - (B) - Ratio	0.4	4	362	207	-	130	124	13	349	207	-	130	124	14	
CHHM08 - 609□SK - (B) - Ratio	0.55	4	403	213	-	140	148	16	446	213	-	140	148	18	
CHHM1 - 609□SK - (B) - Ratio	0.75	4	403	213	-	140	148	16	446	213	-	140	148	18	
CHHM1H - 609□SK - (B) - Ratio	1.1	4	436	220	-	145	160	21	498	220	-	145	160	25	
CHHM2 - 609□SK - (B) - Ratio	1.5	4	436	220	-	145	160	21	498	220	-	145	160	25	
CHHM3 - 609□SK - (B) - Ratio	2.2	4	456	226	-	152	173	25	519	226	-	152	173	31	

Note: 1. □ indicates motor capacity.
 2. Dimension of shaft end diameter: Dimension tolerance conforms to JIS B 0401-1976 "h6."
 3. Dimension of shaft end key: Dimension tolerance conforms to JIS B 1301-1996 "Parallel Key."

Dimension Tables Gearmotors (Horizontal Direction, Foot-Mount)

CHHM^{Note 1} - 610□SK to 611□SK

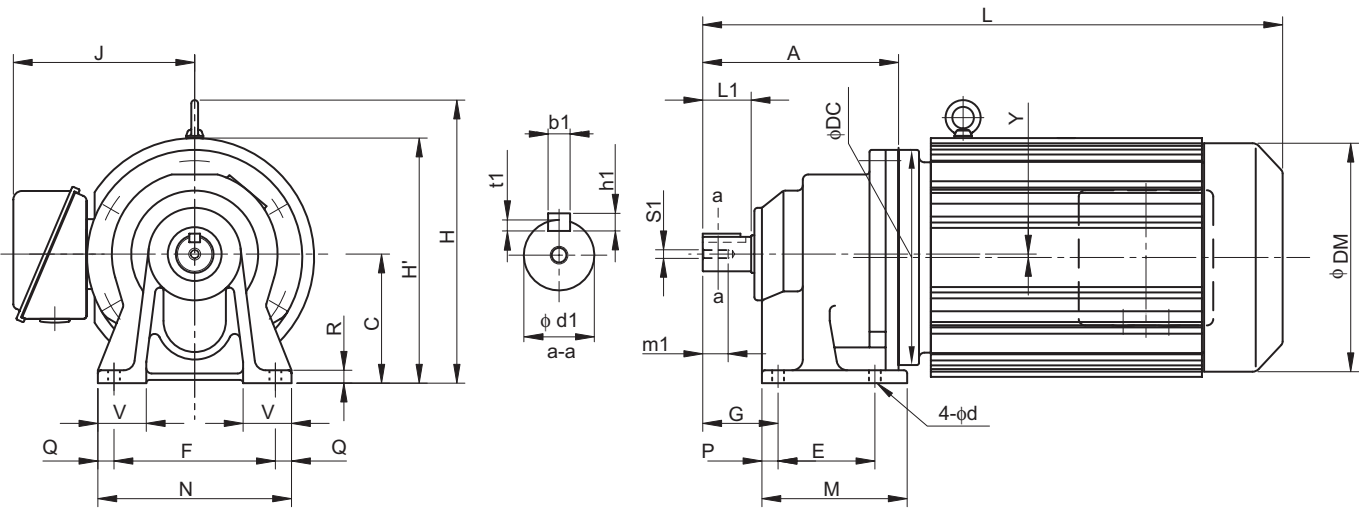

Dimension Tables
CHHM
GEARMOTORS

Frame size <small>Note 4</small>	A	C	DC	E	F	G	M	N	P	Q	R	V	Y	d	Output Shaft <small>Note 2, 3, 6</small>						
															d1	L1	b1	h1	t1	S1	m1
610□SK	170	100	162	90	150	60	135	180	15	15	12	40	0	11	28	35	8	7	4	M8	20
611□SK	182	120	204	90	150	70	135	180	15	15	12	45	3	11	32	45	10	8	5	M8	20

Model <small>Note 4, 5</small>	Motor		Standard						With Brake					
	kW	P	L	H	H'	J	DM	W(kg)	L	H	H'	J	DM	W(kg)
CHHM05 -610□SK - (B) - Ratio	0.4	4	362	216	-	130	124	14	393	216	-	130	124	15
CHHM08 -610□SK - (B) - Ratio	0.55	4	403	216	-	140	148	17	452	216	-	140	148	19
CHHM1 -610□SK - (B) - Ratio	0.75	4	403	216	-	140	148	17	452	216	-	140	148	19
CHHM1H -610□SK - (B) - Ratio	1.1	4	436	220	-	145	160	22	493	220	-	145	160	26
CHHM2 -610□SK - (B) - Ratio	1.5	4	436	220	-	145	160	22	493	220	-	145	160	26
CHHM3 -610□SK - (B) - Ratio	2.2	4	456	226	-	152	173	26	519	226	-	152	173	32
CHHM4 -610□SK - (B) - Ratio	3.0	4	491	246	-	168	212	38	563	246	-	168	212	49
CHHM5 -610□SK - (B) - Ratio	3.7	4	491	246	-	168	212	38	563	246	-	168	212	49
CHHM08 -611□SK - (B) - Ratio	0.55	4	419	230	-	140	148	29	462	230	-	140	148	31
CHHM1 -611□SK - (B) - Ratio	0.75	4	419	230	-	140	148	29	462	230	-	140	148	31
CHHM1H -611□SK - (B) - Ratio	1.1	4	452	237	-	145	160	34	514	237	-	145	160	38
CHHM2 -611□SK - (B) - Ratio	1.5	4	452	237	-	145	160	34	514	237	-	145	160	38
CHHM3 -611□SK - (B) - Ratio	2.2	4	472	243	-	152	173	38	535	243	-	152	173	44
CHHM4 -611□SK - (B) - Ratio	3.0	4	495	263	-	168	212	50	567	263	-	168	212	61
CHHM5 -611□SK - (B) - Ratio	3.7	4	495	263	-	168	212	50	567	263	-	168	212	61
CHHM8 -611□SK - (B) - Ratio	5.5	4	539	263	-	168	212	58	611	263	-	168	212	69

Note: 4. □ indicates 0 or 5, expressing combination with reduction ratio. Refer to the Selection Table for details.
 5. "B" after the frame size indicates models equipped with brake.
 6. Dimension of shaft end: Refer to pages F-28 to F-29 for details.
 7. Dimensions in above drawings are subject to change without notice.

Dimension Tables Gearmotors (Universal Direction, Foot-Mount)

CNHM^{Note 1} - 606□ to 609□

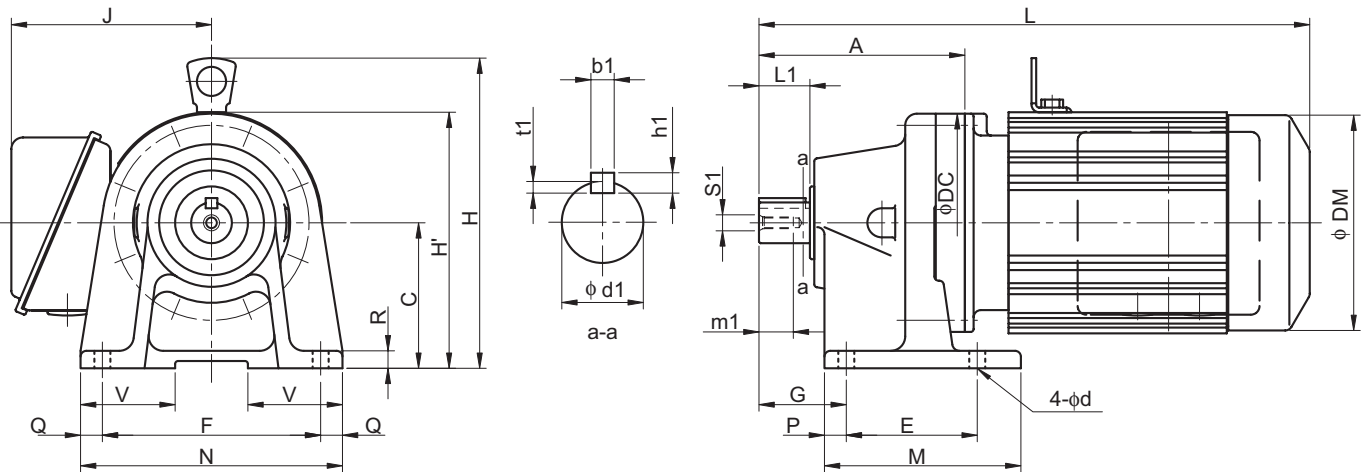

Frame size <small>Note 4</small>	A	C	DC	E	F	G	M	N	P	Q	R	V	d	Output Shaft <small>Note 2, 3, 6</small>						
														d1	L1	b1	h1	t1	S1	m1
606□	92	80	110	60	120	41	84	144	12	12	10	35	9	14	25	5	5	3	M5	16
607□	98	80	110	60	120	47	84	144	12	12	10	35	9	18	30	6	6	3.5	M6	16
608□	129	90	134	75	120	52	99	144	12	12	13	37	9	22	35	6	6	3.5	M6	16
609□	142	100	150	90	150	60	135	180	15	15	12	40	11	28	35	8	7	4	M8	20

Model <small>Note 4, 5</small>	Motor		Standard						With Brake					
	kW	P	L	H	H'	J	DM	W(kg)	L	H	H'	J	DM	W(kg)
CNHM01 - 606□ - (B) - Ratio	0.1	4	254	-	140	130	119	7	261	-	138	130	124	8
CNHM02 - 606□ - (B) - Ratio	0.2	4	272	-	138	130	124	8	300	-	138	130	124	9
CNHM03 - 606□ - (B) - Ratio	0.25	4	272	-	138	130	124	8	300	-	138	130	124	9
CNHM01 - 607□ - (B) - Ratio	0.1	4	260	-	140	130	119	7	267	-	138	130	124	8
CNHM02 - 607□ - (B) - Ratio	0.2	4	278	-	138	130	124	8	306	-	138	130	124	9
CNHM03 - 607□ - (B) - Ratio	0.25	4	278	-	138	130	124	8	306	-	138	130	124	9
CNHM05 - 607□ - (B) - Ratio	0.4	4	294	-	138	130	124	9	326	-	138	130	124	10
CNHM01 - 608□ - (B) - Ratio	0.1	4	286	-	157	130	119	10	293	-	157	130	124	11
CNHM02 - 608□ - (B) - Ratio	0.2	4	304	-	157	130	124	11	332	-	157	130	124	12
CNHM03 - 608□ - (B) - Ratio	0.25	4	304	-	157	130	124	11	332	-	157	130	124	12
CNHM05 - 608□ - (B) - Ratio	0.4	4	320	-	157	130	124	13	352	-	157	130	124	14
CNHM08 - 608□ - (B) - Ratio	0.55	4	361	203	-	140	148	17	404	203	-	140	148	18
CNHM1 - 608□ - (B) - Ratio	0.75	4	361	203	-	140	148	17	404	203	-	140	148	18
CNHM01 - 609□ - (B) - Ratio	0.1	4	304	-	175	130	119	12	311	-	175	130	124	14
CNHM02 - 609□ - (B) - Ratio	0.2	4	322	-	175	130	124	13	350	-	175	130	124	15
CNHM03 - 609□ - (B) - Ratio	0.25	4	322	-	175	130	124	13	350	-	175	130	124	15
CNHM05 - 609□ - (B) - Ratio	0.4	4	338	-	175	130	124	14	370	-	175	130	124	16
CNHM08 - 609□ - (B) - Ratio	0.55	4	379	213	-	140	148	18	422	213	-	140	148	21
CNHM1 - 609□ - (B) - Ratio	0.75	4	379	213	-	140	148	18	422	213	-	140	148	21
CNHM1H - 609□ - (B) - Ratio	1.1	4	412	220	-	145	160	21	474	220	-	145	160	26
CNHM2 - 609□ - (B) - Ratio	1.5	4	412	220	-	145	160	21	474	220	-	145	160	26

Note: 1. □ indicates motor capacity.
 2. Dimension of shaft end diameter: Dimension tolerance conforms to JIS B 0401-1976 "h6."
 3. Dimension of shaft end key: Dimension tolerance conforms to JIS B 1301-1996 "Parallel Key."

Dimension Tables Gearmotors (Universal Direction, Foot-Mount)

CNHM^{Note 1} - 610□ to 612□

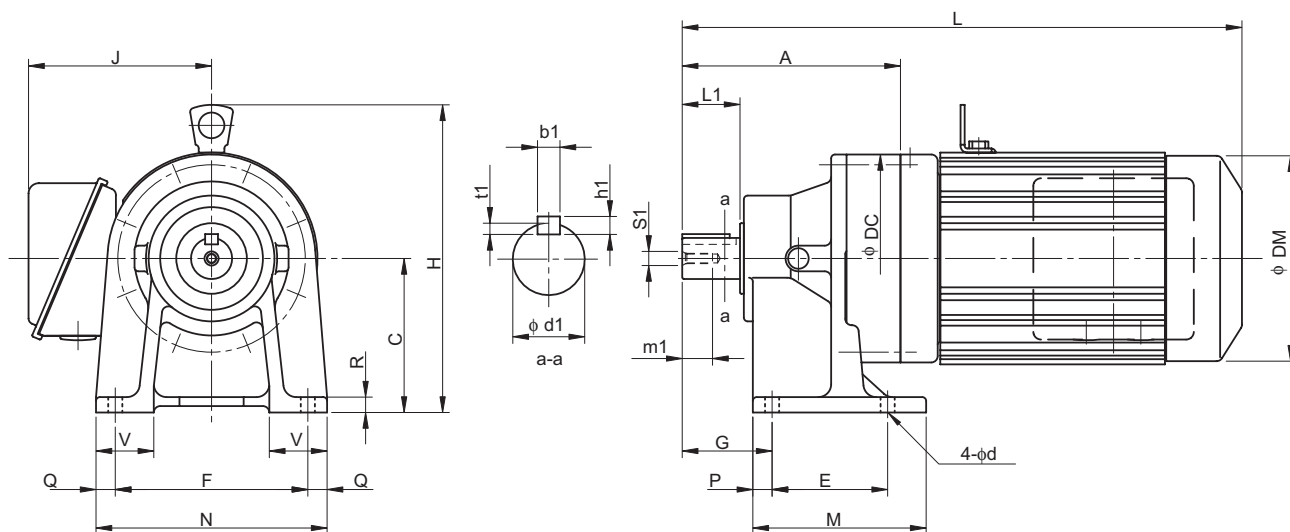

GEARMOTORS
Dimension Tables
CNHM

Frame size <small>Note 4</small>	A	C	DC	E	F	G	M	N	P	Q	R	V	d	Output Shaft <small>Note 2, 3, 6</small>						
														d1	L1	b1	h1	t1	S1	m1
610□	156	100	150	90	150	60	135	180	15	15	12	40	11	28	35	8	7	4	M8	20
611□	170	120	162	90	150	70	135	180	15	15	12	45	11	32	45	10	8	5	M8	20
612□	186	120	204	115	190	82	155	230	20	20	15	55	14	38	55	10	8	5	M8	20

Model <small>Note 4, 5</small>	Motor		Standard						With Brake				
	kW	P	L	H	J	DM	W(kg)	L	H	J	DM	W(kg)	
CNHM02 - 610□ - (B) - Ratio	0.2	4	336	207	130	124	18	364	207	130	124	20	
CNHM03 - 610□ - (B) - Ratio	0.25	4	336	207	130	124	18	364	207	130	124	20	
CNHM05 - 610□ - (B) - Ratio	0.4	4	352	207	130	124	19	384	207	130	124	21	
CNHM08 - 610□ - (B) - Ratio	0.55	4	393	213	140	148	23	436	213	140	148	26	
CNHM1 - 610□ - (B) - Ratio	0.75	4	393	213	140	148	23	436	213	140	148	26	
CNHM1H - 610□ - (B) - Ratio	1.1	4	426	220	145	160	27	488	220	145	160	32	
CNHM2 - 610□ - (B) - Ratio	1.5	4	426	220	145	160	27	488	220	145	160	32	
CNHM3 - 610□ - (B) - Ratio	2.2	4	446	226	152	173	31	509	226	152	173	37	
CNHM05 - 611□ - (B) - Ratio	0.4	4	363	236	130	124	20	394	236	130	124	21	
CNHM08 - 611□ - (B) - Ratio	0.55	4	403	236	140	148	23	452	236	140	148	26	
CNHM1 - 611□ - (B) - Ratio	0.75	4	403	236	140	148	23	452	236	140	148	26	
CNHM1H - 611□ - (B) - Ratio	1.1	4	436	240	145	160	26	493	240	145	160	31	
CNHM2 - 611□ - (B) - Ratio	1.5	4	436	240	145	160	26	493	240	145	160	31	
CNHM3 - 611□ - (B) - Ratio	2.2	4	456	246	152	173	30	519	246	152	173	36	
CNHM4 - 611□ - (B) - Ratio	3.0	4	491	266	168	212	40	563	266	168	212	50	
CNHM5 - 611□ - (B) - Ratio	3.7	4	491	266	168	212	40	563	266	168	212	50	
CNHM05 - 612□ - (B) - Ratio	0.4	4	387	257	130	124	30	419	257	130	124	32	
CNHM08 - 612□ - (B) - Ratio	0.55	4	423	233	140	148	32	466	233	140	148	35	
CNHM1 - 612□ - (B) - Ratio	0.75	4	423	233	140	148	32	466	233	140	148	35	
CNHM1H - 612□ - (B) - Ratio	1.1	4	456	240	145	160	36	518	240	145	160	41	
CNHM2 - 612□ - (B) - Ratio	1.5	4	456	240	145	160	36	518	240	145	160	41	
CNHM3 - 612□ - (B) - Ratio	2.2	4	476	246	152	173	40	539	246	152	173	47	
CNHM4 - 612□ - (B) - Ratio	3.0	4	499	266	168	212	50	571	266	168	212	60	
CNHM5 - 612□ - (B) - Ratio	3.7	4	499	266	168	212	50	571	266	168	212	60	
CNHM8 - 612□ - (B) - Ratio	5.5	4	543	266	168	212	57	615	266	168	212	67	

Note: 4. □ indicates 0 or 5, expressing combination with reduction ratio. Refer to the Selection Table for details.
 5. "B" after the frame size indicates models equipped with brake.
 6. Dimension of shaft end: Refer to pages F-28 to F-29 for details.
 7. Dimensions in above drawings are subject to change without notice.

Dimension Tables Gearmotors (Horizontal Direction, Foot-Mount)

CHHM^{Note 1} - 613□ to 614□

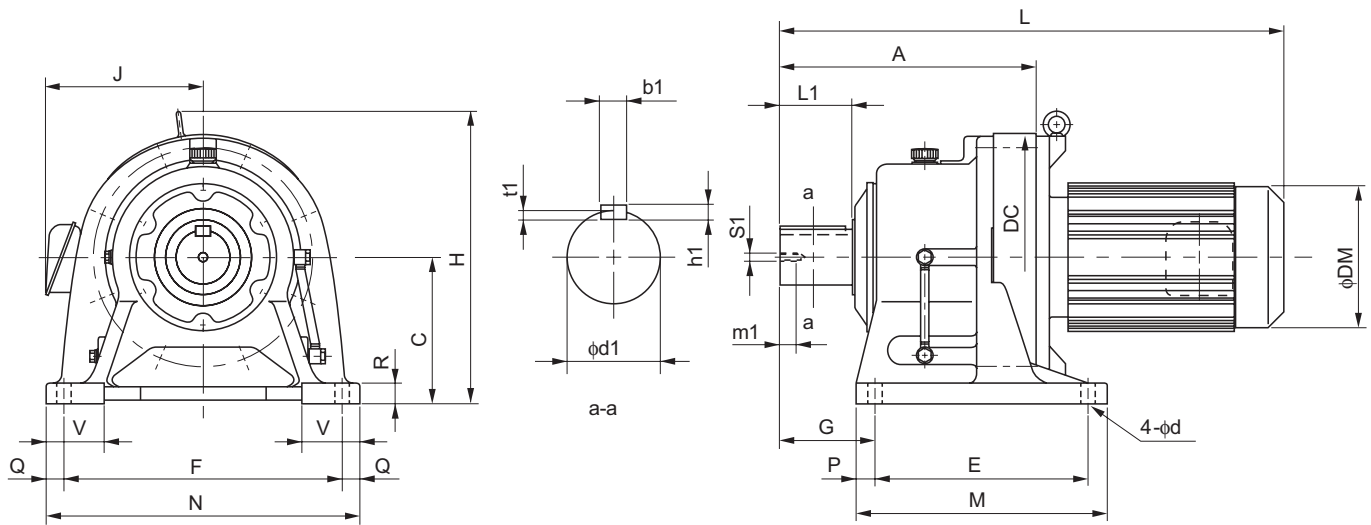

Frame size <small>Note 4</small>	A	C	DC	E	F	G	M	N	P	Q	R	V	d	Output Shaft <small>Note 2, 3, 6</small>						
														d1	L1	b1	h1	t1	S1	m1
613□	240	150	230	145	290	100	195	330	25	20	22	65	18	50	70	14	9	5.5	M10	18
614□	260	150	230	145	290	120	195	330	25	20	22	65	18	50	90	14	9	5.5	M10	18

Model <small>Note 4, 5</small>	Motor		Standard							With Brake				
	kW	P	L	H	J	DM	W(kg)	L	H	J	DM	W(kg)		
CHHM08 - 613□	- (B)	- Ratio	0.55	4	477	265	140	148	51	520	265	140	148	54
CHHM1 - 613□	- (B)	- Ratio	0.75	4	477	265	140	148	51	520	265	140	148	54
CHHM1H - 613□	- (B)	- Ratio	1.1	4	510	268	145	160	55	572	268	145	160	60
CHHM2 - 613□	- (B)	- Ratio	1.5	4	510	268	145	160	55	572	268	145	160	60
CHHM3 - 613□	- (B)	- Ratio	2.2	4	530	274	152	173	58	593	274	152	173	65
CHHM4 - 613□	- (B)	- Ratio	3.0	4	553	296	168	212	68	625	296	168	212	78
CHHM5 - 613□	- (B)	- Ratio	3.7	4	553	296	168	212	68	625	296	168	212	78
CHHM8 - 613□	- (B)	- Ratio	5.5	4	597	296	168	212	75	669	296	168	212	85
CHHM10 - 613□	- (B)	- Ratio	7.5	4	620	323	213	251	90	715	323	213	251	108
CHHM15 - 613□	- (B)	- Ratio	11	4	680	323	213	251	104	775	323	213	251	121
CHHM1 - 614□	- (B)	- Ratio	0.75	4	497	268	140	148	52	540	268	140	148	55
CHHM1H - 614□	- (B)	- Ratio	1.1	4	530	268	145	160	56	592	268	145	160	61
CHHM2 - 614□	- (B)	- Ratio	1.5	4	530	268	145	160	56	592	268	145	160	61
CHHM3 - 614□	- (B)	- Ratio	2.2	4	550	274	152	173	59	613	274	152	173	66
CHHM4 - 614□	- (B)	- Ratio	3.0	4	573	296	168	212	69	645	296	168	212	79
CHHM5 - 614□	- (B)	- Ratio	3.7	4	573	296	168	212	69	645	296	168	212	79
CHHM8 - 614□	- (B)	- Ratio	5.5	4	617	296	168	212	76	689	296	168	212	86
CHHM10 - 614□	- (B)	- Ratio	7.5	4	640	323	213	251	91	735	323	213	251	109
CHHM15 - 614□	- (B)	- Ratio	11	4	700	323	213	251	104	795	323	213	251	122
CHHM20 - 614□	- (B)	- Ratio	15	4	790	358	261	324	156	880	321	261	324	190

Note: 1. □ indicates motor capacity.
2. Dimension of shaft end diameter: Dimension tolerance conforms to JIS B 0401-1976 "h6."
3. Dimension of shaft end key: Dimension tolerance conforms to JIS B 1301-1996 "Parallel Key."

Dimension Tables Gearmotors (Horizontal Direction, Foot-Mount)

CHHM^{Note 1} - 616□ to 617□

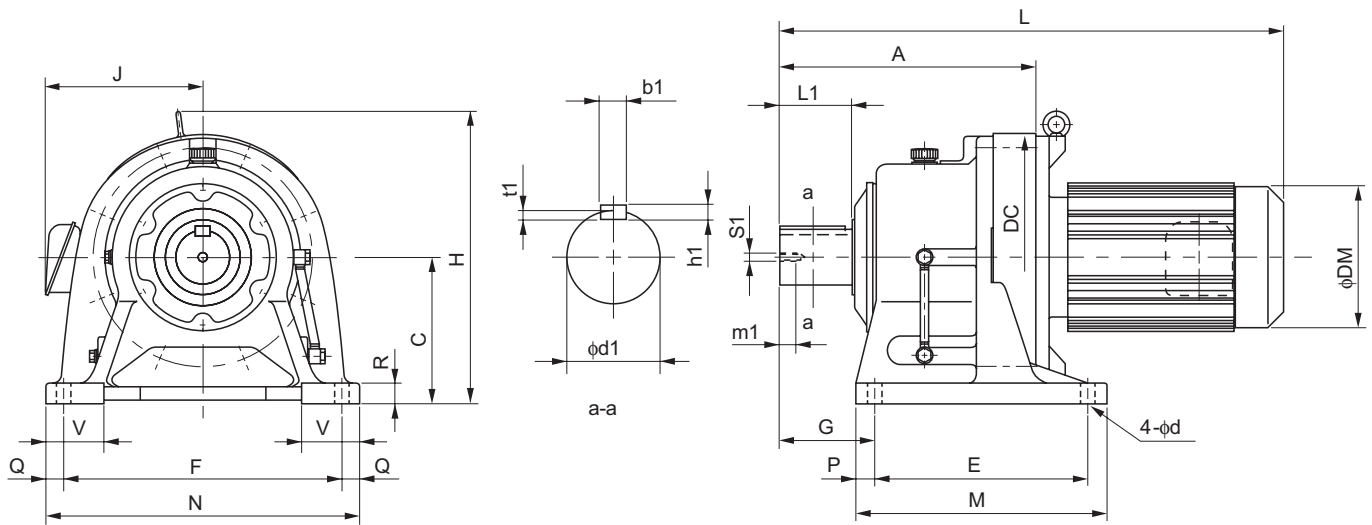

GEARMOTORS
Dimension Tables
CHHM

Frame size <small>Note 4</small>	A	C	DC	E	F	G	M	N	P	Q	R	V	d	Output Shaft <small>Note 2, 3, 6</small>						
														d1	L1	b1	h1	t1	S1	m1
616□	308	160	300	150	370	139	238	410	44	20	25	75	18	60	90	18	11	7	M10	18
617□	352	200	340	275	380	125	335	430	30	25	30	80	22	70	90	20	12	7.5	M12	24

Model <small>Note 4, 5</small>	Motor		Standard					With Brake				
	kW	P	L	H	J	DM	W(kg)	L	H	J	DM	W(kg)
CHHM1H - 616□ - (B) - Ratio	1.1	4	583	310	145	160	93	645	310	145	160	99
CHHM2 - 616□ - (B) - Ratio	1.5	4	583	310	145	160	93	645	310	145	160	99
CHHM3 - 616□ - (B) - Ratio	2.2	4	598	310	152	173	96	661	310	152	173	103
CHHM4 - 616□ - (B) - Ratio	3.0	4	621	310	168	212	105	693	310	168	212	116
CHHM5 - 616□ - (B) - Ratio	3.7	4	621	310	168	212	105	693	310	168	212	116
CHHM8 - 616□ - (B) - Ratio	5.5	4	665	310	168	212	112	737	310	168	212	123
CHHM10 - 616□ - (B) - Ratio	7.5	4	693	333	213	251	128	788	333	213	251	146
CHHM15 - 616□ - (B) - Ratio	11	4	753	333	213	251	142	848	333	213	251	160
*CHHM20 - 616□ - (B) - Ratio	15	4	838	368	261	324	195	928	368	261	324	230
*CHHM25 - 616□ - (B) - Ratio	18.5	4	933	368	340	394	267	1098	368	340	394	323
*CHHM30 - 616□ - (B) - Ratio	22	4	933	368	340	394	267	1098	368	340	394	323
CHHM4 - 617□ - (B) - Ratio	3.0	4	680	403	168	212	146	752	403	168	212	157
CHHM5 - 617□ - (B) - Ratio	3.7	4	680	403	168	212	146	752	403	168	212	157
CHHM8 - 617□ - (B) - Ratio	5.5	4	724	403	168	212	153	796	403	168	212	164
CHHM10 - 617□ - (B) - Ratio	7.5	4	742	403	213	251	168	837	403	213	251	187
CHHM15 - 617□ - (B) - Ratio	11	4	802	403	213	251	182	897	403	213	251	201
CHHM20 - 617□ - (B) - Ratio	15	4	882	413	259	324	236	987	413	259	324	271
CHHM25 - 617□ - (B) - Ratio	18.5	4	977	428	340	394	304	1142	428	340	394	360
CHHM30 - 617□ - (B) - Ratio	22	4	977	428	340	394	304	1142	428	340	394	360
CHHM40 - 617□ - (B) - Ratio	30	4	977	428	340	394	321	1142	428	340	394	369

*** indicates models with bottom level of the motor lower than the reducer base.
Refer to pages B-152 and B-153 for center height options.

- Note: 4. □ indicates 0 or 5, expressing combination with reduction ratio. Refer to the Selection Table for details.
5. "B" after the frame size indicates models equipped with brake.
6. Dimension of shaft end: Refer to pages F-28 to F-29 for details.
7. Dimensions in above drawings are subject to change without notice.

Dimension Tables Gearmotors (Horizontal Direction, Foot-Mount)

CHHM^{Note 1} - 618□ to 619□

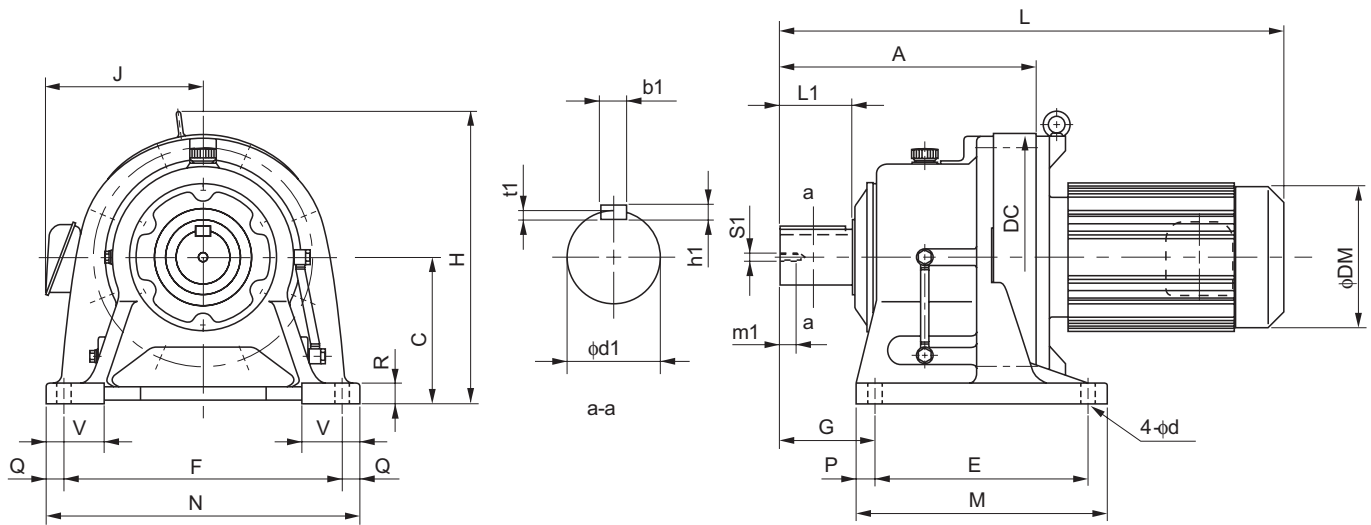

Frame size <small>Note 4</small>	A	C	DC	E	F	G	M	N	P	Q	R	V	d	Output Shaft <small>Note 2, 3, 6</small>						
														d1	L1	b1	h1	t1	S1	m1
618□	389	220	370	320	420	145	380	470	30	25	30	85	22	80	110	22	14	9	M12	24
619□	465	250	430	380	480	170	440	530	30	25	35	90	26	95	135	25	14	9	M20	34

Model <small>Note 4, 5</small>	Motor		Standard							With Brake				
	kW	P	L	H	J	DM	W(kg)	L	H	J	DM	W(kg)		
CHHM4 - 618□ - (B) - Ratio	3.0	4	717	438	168	212	184	789	438	168	212	194		
CHHM5 - 618□ - (B) - Ratio	3.7	4	717	438	168	212	184	789	438	168	212	194		
CHHM8 - 618□ - (B) - Ratio	5.5	4	761	438	168	212	192	833	438	168	212	202		
CHHM10 - 618□ - (B) - Ratio	7.5	4	779	438	213	251	207	874	438	213	251	225		
CHHM15 - 618□ - (B) - Ratio	11	4	839	438	213	251	221	934	438	213	251	239		
CHHM20 - 618□ - (B) - Ratio	15	4	919	438	261	324	281	1024	438	261	324	310		
CHHM25 - 618□ - (B) - Ratio	18.5	4	1014	448	340	394	347	1179	448	340	394	398		
CHHM30 - 618□ - (B) - Ratio	22	4	1014	448	340	394	347	1179	448	340	394	398		
CHHM40 - 618□ - (B) - Ratio	30	4	1014	448	340	394	364	1179	448	340	394	407		
CHHM50 - 618□ - (B) - Ratio	37	4	1129	481	340	394	412	1344	481	340	394	509		
CHHM60 - 618□ - (B) - Ratio	45	4	1129	481	340	394	412	1344	481	340	394	509		
CHHM8 - 619□ - (B) - Ratio	5.5	4	857	511	168	212	266	929	511	168	212	276		
CHHM10 - 619□ - (B) - Ratio	7.5	4	870	511	213	251	279	965	511	213	251	297		
CHHM15 - 619□ - (B) - Ratio	11	4	930	511	213	251	293	1025	511	213	251	311		
CHHM20 - 619□ - (B) - Ratio	15	4	995	467	261	324	346	1100	467	261	324	381		
CHHM25 - 619□ - (B) - Ratio	18.5	4	1090	511	340	394	422	1255	511	340	394	467		
CHHM256 - 619□ - (B) - Ratio	18.5	6	1090	511	340	394	437	1255	511	340	394	480		
CHHM30 - 619□ - (B) - Ratio	22	4	1090	511	340	394	422	1255	511	340	394	467		
CHHM40 - 619□ - (B) - Ratio	30	4	1090	511	340	394	437	1255	511	340	394	480		
CHHM406 - 619□ - (B) - Ratio	30	6	1205	511	340	394	475	1420	511	340	394	572		
CHHM50 - 619□ - (B) - Ratio	37	4	1205	511	340	394	475	1420	511	340	394	572		
CHHM506 - 619□ - (B) - Ratio	37	6	1205	511	340	394	475	1420	511	340	394	572		
CHHM60 - 619□ - (B) - Ratio	45	4	1205	511	340	394	475	1420	511	340	394	572		

Note: 1. □ indicates motor capacity.
 2. Dimension of shaft end diameter: Dimension tolerance conforms to JIS B 0401-1976 "h6."
 3. Dimension of shaft end key: Dimension tolerance conforms to JIS B 1301-1996 "Parallel Key."

Dimension Tables Gearmotors (Horizontal Direction, Foot-Mount)

CHHM^{Note 1} - 6205 to 6215

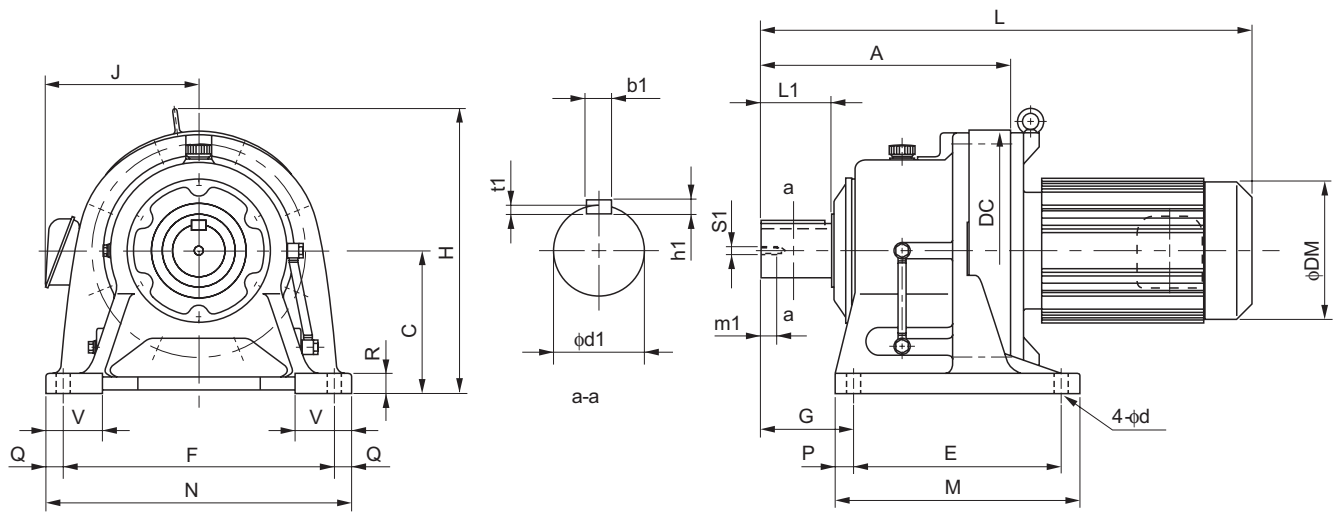

GEARMOTORS
Dimension Tables
CHHM

Frame size	A	C	DC	E	F	G	M	N	P	Q	R	V	d	Output Shaft ^{Note 2, 3, 6}						
														d1	L1	b1	h1	t1	S1	m1
6205	502	250	448	360	440	215	440	530	40	45	35	100	26	100	165	28	16	10	M20	34
6215	526	265	485	395	480	210	475	580	40	50	40	110	26	110	165	28	16	10	M20	34

Model	Note 5	Motor		Standard					With Brake				
		kW	P	L	H	J	DM	W(kg)	L	H	J	DM	W(kg)
CHHM15 - 6205	-(B) - Ratio	11	4	972	530	213	251	313	1067	530	213	251	332
CHHM20 - 6205	-(B) - Ratio	15	4	1042	530	261	324	367	1147	530	261	324	404
CHHM206 - 6205	-(B) - Ratio	15	6	1127	530	340	394	438	1292	530	340	394	484
CHHM25 - 6205	-(B) - Ratio	18.5	4	1127	530	340	394	438	1292	530	340	394	488
CHHM30 - 6205	-(B) - Ratio	22	4	1127	530	340	394	438	1292	530	340	394	488
CHHM306 - 6205	-(B) - Ratio	22	6	1127	530	340	394	451	1292	530	340	394	501
CHHM40 - 6205	-(B) - Ratio	30	4	1127	530	340	394	451	1292	530	340	394	501
CHHM406 - 6205	-(B) - Ratio	30	6	1242	530	340	394	489	1457	530	340	394	588
CHHM50 - 6205	-(B) - Ratio	37	4	1242	530	340	394	489	1457	530	340	394	588
CHHM506 - 6205	-(B) - Ratio	37	6	1242	530	340	394	489	1457	530	340	394	588
CHHM60 - 6205	-(B) - Ratio	45	4	1242	530	340	394	489	1457	530	340	394	588
CHHM606 - 6205	-(B) - Ratio	45	6	1297	575	390	484	582	-	-	-	-	-
CHHM75 - 6205	-(B) - Ratio	55	4	1297	575	390	484	582	-	-	-	-	-
CHHM15 - 6215	-(B) - Ratio	11	4	996	575	213	251	395	1091	575	213	251	414
CHHM20 - 6215	-(B) - Ratio	15	4	1066	575	261	324	450	1171	575	261	324	486
CHHM206 - 6215	-(B) - Ratio	15	6	1151	575	340	394	515	1316	575	340	394	565
CHHM25 - 6215	-(B) - Ratio	18.5	4	1151	575	340	394	515	1316	575	340	394	565
CHHM256 - 6215	-(B) - Ratio	18.5	6	1151	575	340	394	528	1316	575	340	394	578
CHHM30 - 6215	-(B) - Ratio	22	4	1151	575	340	394	515	1316	575	340	394	565
CHHM306 - 6215	-(B) - Ratio	22	6	1151	575	340	394	528	1316	575	340	394	578
CHHM40 - 6215	-(B) - Ratio	30	4	1151	575	340	394	528	1316	575	340	394	578
CHHM406 - 6215	-(B) - Ratio	30	6	1266	575	340	394	566	1481	575	340	394	666
CHHM50 - 6215	-(B) - Ratio	37	4	1266	575	340	394	566	1481	575	340	394	666
CHHM506 - 6215	-(B) - Ratio	37	6	1266	575	340	394	566	1481	575	340	394	666
CHHM60 - 6215	-(B) - Ratio	45	4	1266	575	340	394	566	1481	575	340	394	666
CHHM606 - 6215	-(B) - Ratio	45	6	1321	575	390	484	676	-	-	-	-	-
CHHM75 - 6215	-(B) - Ratio	55	4	1321	575	390	484	676	-	-	-	-	-

Note: 4. □ indicates 0 or 5, expressing combination with reduction ratio. Refer to the Selection Table for details.
 5. "B" after the frame size indicates models equipped with brake.
 6. Dimension of shaft end: Refer to pages F-28 to F-29 for details.
 7. Dimensions in above drawings are subject to change without notice.

Dimension Tables Gearmotors (Horizontal Direction, Foot-Mount)

CHHM^{Note 1} - 6225 to 6235

GEARMOTORS
Dimension Tables
CHHM

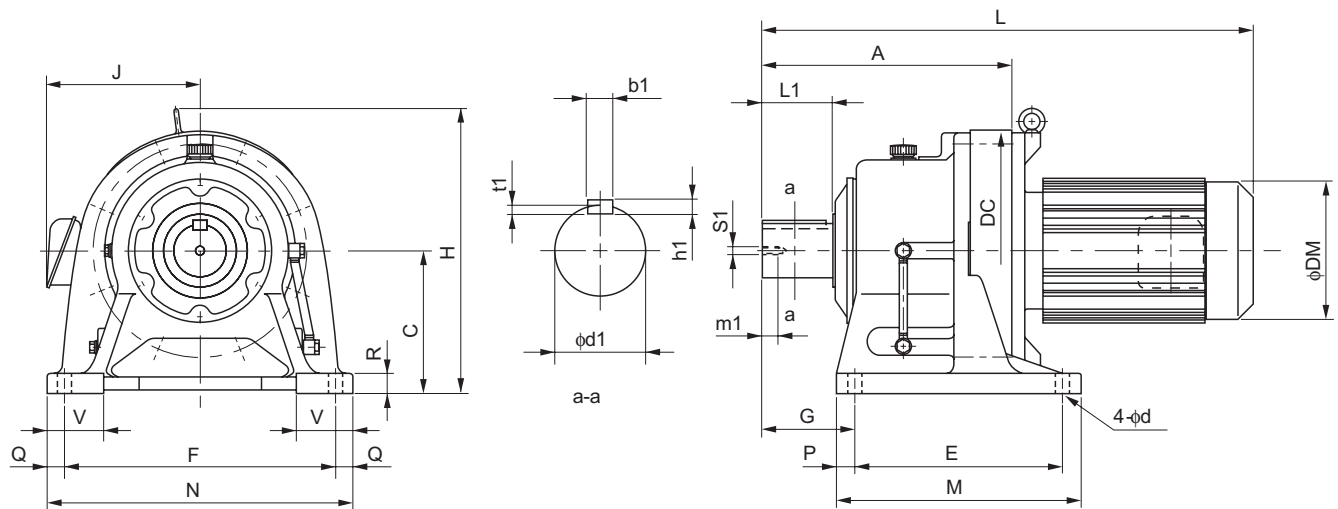

Frame size	A	C	DC	E	F	G	M	N	P	Q	R	V	d	Output Shaft <small>Note 2, 3, 5</small>						
														d1	L1	b1	h1	t1	S1	m1
6225	566	280	526	420	540	230	520	620	50	40	40	115	33	120	165	32	18	11	M20	34
6235	628	300	562	460	580	260	560	670	50	45	45	120	33	130	200	32	18	11	M24	41

Model	Note 4	Motor		Standard					With Brake				
		kW	P	L	H	J	DM	W(kg)	L	H	J	DM	W(kg)
CHHM206 - 6225	-(B) - Ratio	15	6	1191	610	340	394	600	1356	610	340	394	650
CHHM25 - 6225	-(B) - Ratio	18.5	4	1191	610	340	394	600	1356	610	340	394	650
CHHM256 - 6225	-(B) - Ratio	18.5	6	1191	610	340	394	613	1356	610	340	394	663
CHHM30 - 6225	-(B) - Ratio	22	4	1191	610	340	394	600	1356	610	340	394	650
CHHM306 - 6225	-(B) - Ratio	22	6	1191	610	340	394	613	1356	610	340	394	663
CHHM40 - 6225	-(B) - Ratio	30	4	1191	610	340	394	613	1356	610	340	394	663
CHHM406 - 6225	-(B) - Ratio	30	6	1306	610	340	394	651	1521	610	340	394	751
CHHM50 - 6225	-(B) - Ratio	37	4	1306	610	340	394	651	1521	610	340	394	751
CHHM506 - 6225	-(B) - Ratio	37	6	1306	610	340	394	651	1521	610	340	394	751
CHHM60 - 6225	-(B) - Ratio	45	4	1306	610	340	394	651	1521	610	340	394	751
CHHM606 - 6225	-(B) - Ratio	45	6	1361	610	390	484	750	-	-	-	-	-
CHHM75 - 6225	-(B) - Ratio	55	4	1361	610	390	484	750	-	-	-	-	-
CHHM206 - 6235	-(B) - Ratio	15	6	1253	667	340	394	698	1448	667	340	394	734
CHHM256 - 6235	-(B) - Ratio	18.5	6	1253	667	340	394	698	1448	667	340	394	748
CHHM306 - 6235	-(B) - Ratio	22	6	1253	667	340	394	698	1448	667	340	394	748
CHHM406 - 6235	-(B) - Ratio	30	6	1368	667	340	394	744	1583	667	340	394	837
CHHM506 - 6235	-(B) - Ratio	37	6	1368	667	340	394	744	1583	667	340	394	837
CHHM606 - 6235	-(B) - Ratio	45	6	1423	667	390	484	833	-	-	-	-	-
CHHM756 - 6235	-(B) - Ratio	55	6	1503	667	390	485	887	-	-	-	-	-

Note: 1. □ indicates motor capacity.
 2. Dimension of shaft end diameter: Dimension tolerance conforms to JIS B 0401-1976 "h6."
 3. Dimension of shaft end key: Dimension tolerance conforms to JIS B 1301-1996 "Parallel Key."

Dimension Tables Gearmotors (Horizontal Direction, Foot-Mount)

CHHM^{Note 1} - 6245 to 6265

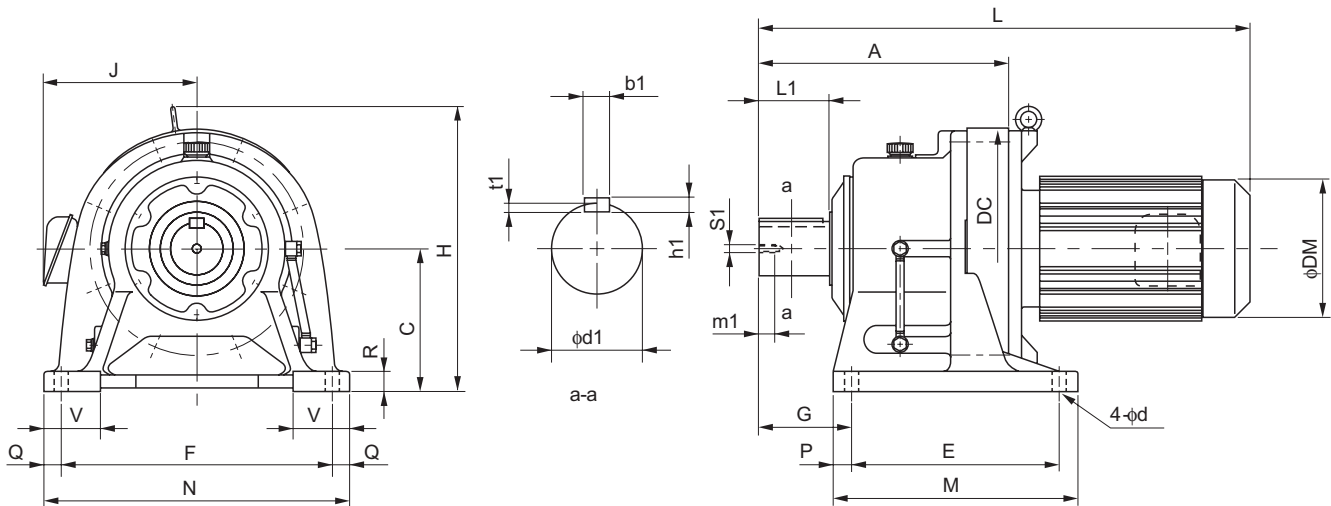

GEARMOTORS
Dimension Tables
CHHM

Frame size	A	C	DC	E	F	G	M	N	P	Q	R	V	d	Output Shaft ^{Note 2, 3, 5}						
														d1	L1	b1	h1	t1	S1	m1
6245	657	335	614	480	630	263	580	720	50	45	45	128	39	140	200	36	20	12	M24	41
6255	775	375	670	520	670	320	630	780	55	55	50	140	39	160	240	40	22	13	M30	49
6265	892	400	736	590	770	390	700	880	55	55	55	160	45	170	300	40	22	13	M30	49

Model	Note 4	Motor		Standard					With Brake				
		kW	P	L	H	J	DM	W(kg)	L	H	J	DM	W(kg)
CHHM206 - 6245	- (B) - Ratio	15	6	1282	729	340	394	824	1447	729	340	394	857
CHHM256 - 6245	- (B) - Ratio	18.5	6	1282	729	340	394	824	1447	729	340	394	871
CHHM306 - 6245	- (B) - Ratio	22	6	1282	729	340	394	824	1447	729	340	394	871
CHHM406 - 6245	- (B) - Ratio	30	6	1397	729	340	394	870	1612	729	340	394	958
CHHM506 - 6245	- (B) - Ratio	37	6	1397	729	340	394	870	1612	729	340	394	958
CHHM606 - 6245	- (B) - Ratio	45	6	1452	729	390	484	961	-	-	-	-	-
CHHM756 - 6245	- (B) - Ratio	55	6	1532	729	390	485	1010	-	-	-	-	-
CHHM206 - 6255	- (B) - Ratio	15	6	1400	815	340	394	1155	1565	815	340	394	1188
CHHM256 - 6255	- (B) - Ratio	18.5	6	1400	815	340	394	1155	1610	815	340	394	1202
CHHM306 - 6255	- (B) - Ratio	22	6	1400	815	340	394	1155	1610	815	340	394	1202
CHHM406 - 6255	- (B) - Ratio	30	6	1515	815	340	394	1200	1730	815	340	394	1288
CHHM506 - 6255	- (B) - Ratio	37	6	1515	815	340	394	1200	1730	815	340	394	1288
CHHM606 - 6255	- (B) - Ratio	45	6	1570	815	390	484	1280	-	-	-	-	-
CHHM756 - 6255	- (B) - Ratio	55	6	1650	815	390	485	1335	-	-	-	-	-
CHHM306 - 6265	- (B) - Ratio	22	6	1517	874	340	394	1400	1727	874	340	394	1447
CHHM406 - 6265	- (B) - Ratio	30	6	1632	874	340	394	1445	1847	874	340	394	1533
CHHM506 - 6265	- (B) - Ratio	37	6	1632	874	340	394	1445	1847	874	340	394	1533
CHHM606 - 6265	- (B) - Ratio	45	6	1687	874	390	484	1540	-	-	-	-	-

Note: 4. "B" after the frame size indicates models equipped with brake.
 5. Dimension of shaft end: Refer to pages F-28 to F-29 for details.
 6. Dimensions in above drawings are subject to change without notice.

Dimension Tables Gearmotors (Universal Direction, Foot-Mount)

CNHM^{Note 1} - 606□DA to 612□DB

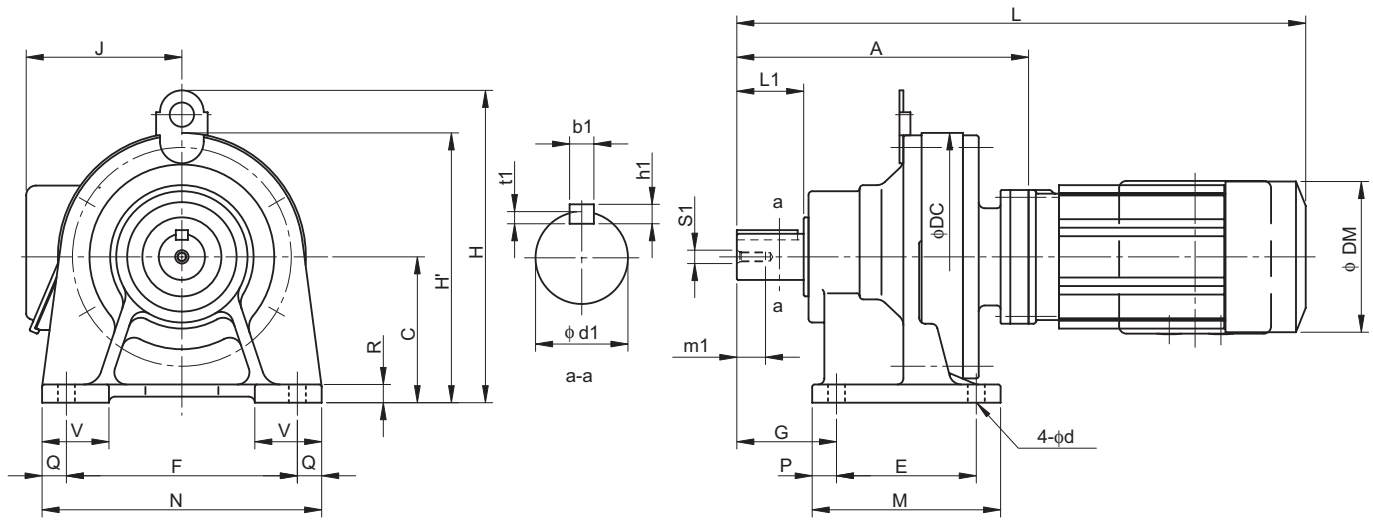

Frame size <small>Note 4</small>	A	C	DC	E	F	G	M	N	P	Q	R	V	d	Output Shaft <small>Note 2, 3, 6</small>						
														d1	L1	b1	h1	t1	S1	m1
606□DA	125	80	110	60	120	41	84	144	12	12	10	35	9	14	25	5	5	3	M5	16
607□DA	131	80	110	60	120	47	84	144	12	12	10	35	9	18	30	6	6	3.5	M6	16
609□DA	190	100	150	90	150	60	135	180	15	15	12	40	11	28	35	8	7	4	M8	20
610□DA	204	100	150	90	150	60	135	180	15	15	12	40	11	28	35	8	7	4	M8	20
612□DA	240	120	204	115	190	82	155	230	20	20	15	55	14	38	55	10	8	5	M8	20
612□DB	252	120	204	115	190	82	155	230	20	20	15	55	14	38	55	10	8	5	M8	20

Model <small>Note 4, 5</small>	Motor		Standard							With Brake					
	kW	P	L	H	H'	J	DM	W(kg)	L	H	H'	J	DM	W(kg)	
CNHM01 - 606□DA - (B) - Ratio	0.1	4	287	-	140	130	119	9	294	-	138	130	124	10	
CNHM01 - 607□DA - (B) - Ratio	0.1	4	293	-	140	130	119	9	300	-	138	130	124	10	
CNHM02 - 607□DA - (B) - Ratio	0.2	4	311	-	140	130	124	10	339	-	138	130	124	11	
CNHM01 - 609□DA - (B) - Ratio	0.1	4	352	207	-	130	119	17	359	207	-	130	124	18	
CNHM02 - 609□DA - (B) - Ratio	0.2	4	370	207	-	130	124	18	398	207	-	130	124	19	
CNHM03 - 609□DA - (B) - Ratio	0.25	4	370	207	-	130	124	18	398	207	-	130	124	19	
CNHM05 - 609□DA - (B) - Ratio	0.4	4	386	207	-	130	124	19	418	207	-	130	124	20	
CNHM01 - 610□DA - (B) - Ratio	0.1	4	366	207	-	130	119	19	373	207	-	130	124	20	
CNHM02 - 610□DA - (B) - Ratio	0.2	4	384	207	-	130	124	20	412	207	-	130	124	21	
CNHM03 - 610□DA - (B) - Ratio	0.25	4	384	207	-	130	124	20	412	207	-	130	124	21	
CNHM05 - 610□DA - (B) - Ratio	0.4	4	400	207	-	130	124	21	432	207	-	130	124	22	
CNHM01 - 612□DA - (B) - Ratio	0.1	4	402	257	-	130	119	30	409	257	-	130	124	31	
CNHM02 - 612□DA - (B) - Ratio	0.2	4	420	257	-	130	124	31	448	257	-	130	124	32	
CNHM03 - 612□DA - (B) - Ratio	0.25	4	420	257	-	130	124	31	448	257	-	130	124	32	
CNHM05 - 612□DA - (B) - Ratio	0.4	4	436	257	-	130	124	32	468	257	-	130	124	33	
CNHM01 - 612□DB - (B) - Ratio	0.1	4	414	257	-	130	119	33	421	257	-	130	124	35	
CNHM02 - 612□DB - (B) - Ratio	0.2	4	432	257	-	130	124	34	473	257	-	130	124	36	
CNHM03 - 612□DB - (B) - Ratio	0.25	4	432	257	-	130	124	34	473	257	-	130	124	36	
CNHM05 - 612□DB - (B) - Ratio	0.4	4	448	257	-	130	124	35	473	257	-	130	124	37	
CNHM08 - 612□DB - (B) - Ratio	0.55	4	489	257	-	140	148	39	532	257	-	140	148	42	
CNHM1 - 612□DB - (B) - Ratio	0.75	4	489	257	-	140	148	39	532	257	-	140	148	42	
CNHM1H - 612□DB - (B) - Ratio	1.1	4	516	257	-	145	160	42	578	257	-	145	160	47	
CNHM2 - 612□DB - (B) - Ratio	1.5	4	516	257	-	145	160	42	578	257	-	145	160	47	

Note: 1. □ indicates motor capacity.
 2. Dimension of shaft end diameter: Dimension tolerance conforms to JIS B 0401-1976 "h6."
 3. Dimension of shaft end key: Dimension tolerance conforms to JIS B 1301-1996 "Parallel Key."

Dimension Tables Gearmotors (Horizontal Direction, Foot-Mount)

CHHM^{Note 1} - 613□DA to 614□DC

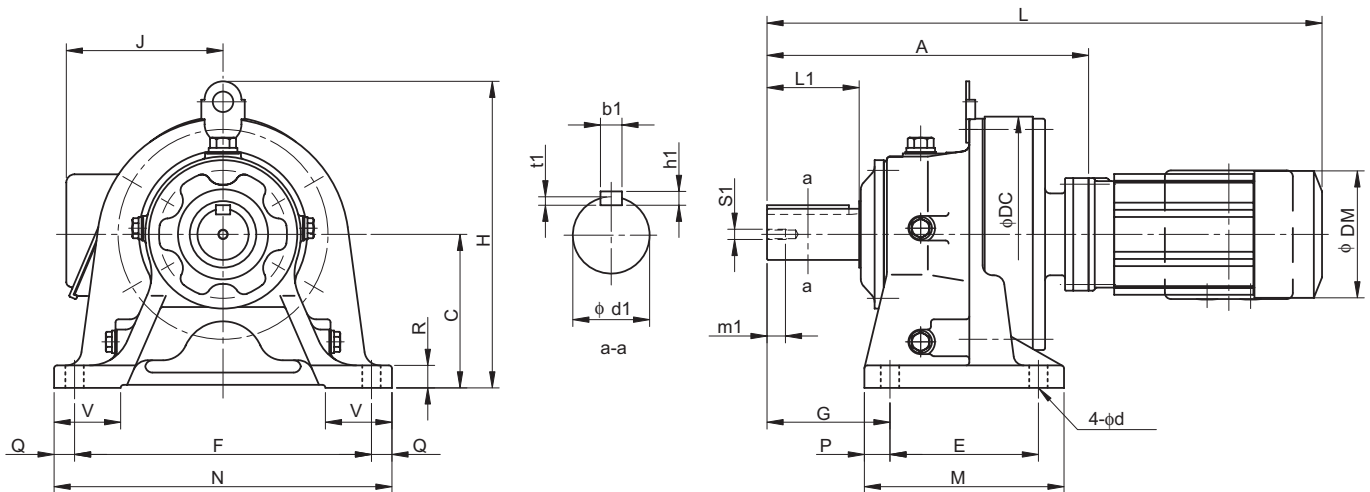

GEARMOTORS
Dimension Tables
CHHM

Frame size <small>Note 4</small>	A	C	DC	E	F	G	M	N	P	Q	R	V	d	Output Shaft <small>Note 2, 3, 6</small>						
														d1	L1	b1	h1	t1	S1	m1
613□DA	294	150	230	145	290	100	195	330	25	20	22	65	18	50	70	14	9	5.5	M10	18
613□DB	303	150	230	145	290	100	195	330	25	20	22	65	18	50	70	14	9	5.5	M10	18
613□DC	317	150	230	145	290	100	195	330	25	20	22	65	18	50	70	14	9	5.5	M10	18
614□DA	314	150	230	145	290	120	195	330	25	20	22	65	18	50	90	14	9	5.5	M10	18
614□DB	323	150	230	145	290	120	195	330	25	20	22	65	18	50	90	14	9	5.5	M10	18
614□DC	337	150	230	145	290	120	195	330	25	20	22	65	18	50	90	14	9	5.5	M10	18

Model <small>Note 4, 5</small>	Motor		Standard					With Brake				
	kW	P	L	H	J	DM	W(kg)	L	H	J	DM	W(kg)
CHHM02 - 613□DA - (B) - Ratio	0.2	4	474	300	130	124	47	502	300	130	124	47
CHHM03 - 613□DA - (B) - Ratio	0.25	4	474	300	130	124	48	522	300	130	124	49
CHHM05 - 613□DA - (B) - Ratio	0.4	4	490	300	130	124	48	522	300	130	124	49
CHHM02 - 613□DB - (B) - Ratio	0.2	4	483	300	130	124	49	511	300	130	124	51
CHHM03 - 613□DB - (B) - Ratio	0.25	4	483	300	130	124	49	511	300	130	124	51
CHHM05 - 613□DB - (B) - Ratio	0.4	4	499	300	130	124	50	531	300	130	124	52
CHHM08 - 613□DB - (B) - Ratio	0.55	4	540	263	140	148	54	583	263	140	148	57
CHHM1 - 613□DB - (B) - Ratio	0.75	4	540	263	140	148	54	583	263	140	148	57
CHHM1H - 613□DB - (B) - Ratio	1.1	4	573	270	145	160	57	635	270	145	160	62
CHHM2 - 613□DB - (B) - Ratio	1.5	4	573	270	145	160	57	635	270	145	160	62
CHHM08 - 613□DC - (B) - Ratio	0.55	4	554	265	140	148	56	597	265	140	148	59
CHHM1 - 613□DC - (B) - Ratio	0.75	4	554	265	140	148	56	597	265	140	148	59
CHHM2 - 613□DC - (B) - Ratio	1.5	4	587	272	145	160	59	649	272	145	160	64
CHHM3 - 613□DC - (B) - Ratio	2.2	4	607	276	152	173	64	670	276	152	173	70
CHHM02 - 614□DA - (B) - Ratio	0.2	4	494	300	130	124	47	522	300	130	124	48
CHHM03 - 614□DA - (B) - Ratio	0.25	4	494	300	130	124	47	522	300	130	124	48
CHHM05 - 614□DA - (B) - Ratio	0.4	4	510	300	130	124	48	542	300	130	124	49
CHHM02 - 614□DB - (B) - Ratio	0.2	4	503	300	130	124	49	531	300	130	124	51
CHHM03 - 614□DB - (B) - Ratio	0.25	4	503	300	130	124	49	531	300	130	124	51
CHHM05 - 614□DB - (B) - Ratio	0.4	4	519	300	130	124	50	551	300	130	124	52
CHHM08 - 614□DB - (B) - Ratio	0.55	4	560	263	140	148	54	603	263	140	148	57
CHHM1 - 614□DB - (B) - Ratio	0.75	4	560	263	140	148	54	603	263	140	148	57
CHHM1H - 614□DB - (B) - Ratio	1.1	4	593	270	145	160	57	655	270	145	160	62
CHHM2 - 614□DB - (B) - Ratio	1.5	4	593	270	145	160	57	655	270	145	160	62
CHHM08 - 614□DC - (B) - Ratio	0.55	4	574	265	140	148	56	617	265	140	148	59
CHHM1 - 614□DC - (B) - Ratio	0.75	4	574	265	140	148	56	617	265	140	148	59
CHHM1H - 614□DC - (B) - Ratio	1.1	4	607	270	145	160	60	669	270	145	160	65
CHHM2 - 614□DC - (B) - Ratio	1.5	4	607	270	145	160	60	669	270	145	160	65
CHHM3 - 614□DC - (B) - Ratio	2.2	4	627	276	152	173	64	690	276	152	173	70

Note: 4. □ indicates 0 or 5, expressing combination with reduction ratio. Refer to the Selection Table for details.
 5. "B" after the frame size indicates models equipped with brake.
 6. Dimension of shaft end: Refer to pages F-28 to F-29 for details.
 7. Dimensions in above drawings are subject to change without notice.

Dimension Tables Gearmotors (Horizontal Direction, Foot-Mount)

CHHM^{Note 1} - 616□DA to 618□DA

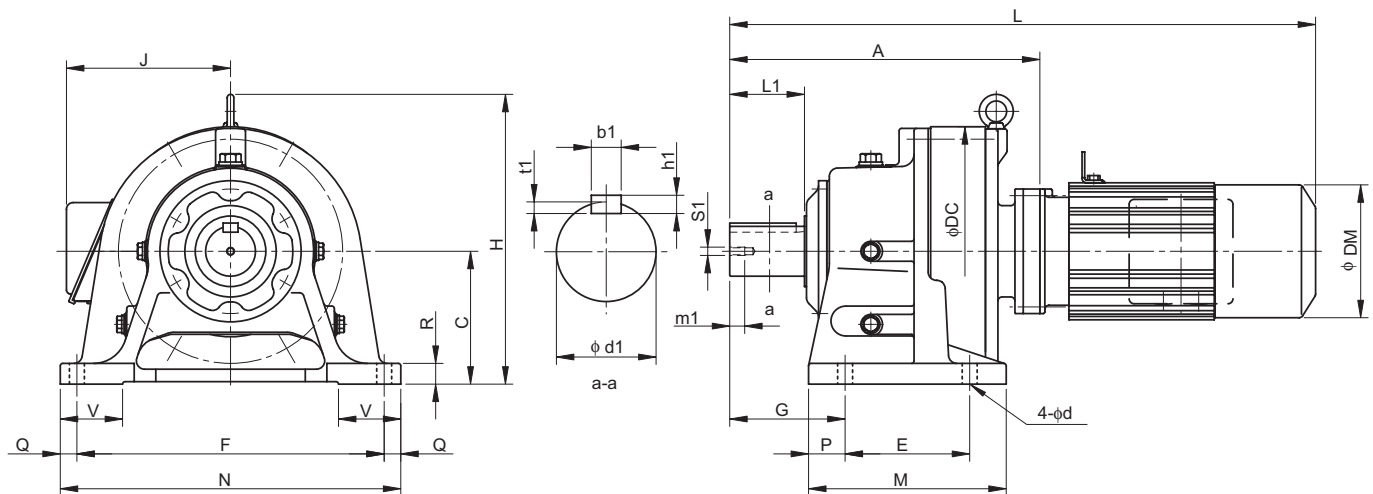

Frame size <small>Note 4</small>	A	C	DC	E	F	G	M	N	P	Q	R	V	d	Output Shaft <small>Note 2, 3, 6</small>						
														d1	L1	b1	h1	t1	S1	m1
616□DA	373	160	300	150	370	139	238	410	44	20	25	75	18	60	90	18	11	7	M10	18
616□DB	387	160	300	150	370	139	238	410	44	20	25	75	18	60	90	18	11	7	M10	18
617□DA	418	200	340	275	380	125	335	430	30	25	30	80	22	70	90	20	12	7.5	M12	24
617□DB	432	200	340	275	380	125	335	430	30	25	30	80	22	70	90	20	12	7.5	M12	24
618□DA	474	220	370	320	420	145	380	470	30	25	30	85	22	80	110	22	14	9	M12	24

Model <small>Note 4, 5</small>	Motor		Standard					With Brake				
	kW	P	L	H	J	DM	W(kg)	L	H	J	DM	W(kg)
CHHM02 - 616□DA - (B) - Ratio	0.2	4	553	349	130	124	90	581	349	130	124	92
CHHM03 - 616□DA - (B) - Ratio	0.25	4	553	349	130	124	90	581	349	130	124	92
CHHM05 - 616□DA - (B) - Ratio	0.4	4	569	349	130	124	91	601	349	130	124	93
CHHM08 - 616□DA - (B) - Ratio	0.55	4	610	349	140	148	95	653	349	140	148	98
CHHM1 - 616□DA - (B) - Ratio	0.75	4	610	349	140	148	95	653	349	140	148	98
CHHM1H - 616□DA - (B) - Ratio	1.1	4	643	349	145	160	99	705	349	145	160	104
CHHM2 - 616□DA - (B) - Ratio	1.5	4	643	349	145	160	99	705	349	145	160	104
CHHM08 - 616□DB - (B) - Ratio	0.55	4	624	349	140	148	97	667	349	140	148	100
CHHM1 - 616□DB - (B) - Ratio	0.75	4	624	349	140	148	97	667	349	140	148	100
CHHM1H - 616□DB - (B) - Ratio	1.1	4	657	349	145	160	101	719	349	145	160	106
CHHM2 - 616□DB - (B) - Ratio	1.5	4	657	349	145	160	101	719	349	145	160	106
CHHM3 - 616□DB - (B) - Ratio	2.2	4	677	349	152	173	105	740	349	152	173	111
CHHM02 - 617□DA - (B) - Ratio	0.2	4	598	416	130	124	120	626	416	130	124	127
CHHM03 - 617□DA - (B) - Ratio	0.25	4	598	416	130	124	120	626	416	130	124	127
CHHM05 - 617□DA - (B) - Ratio	0.4	4	614	416	130	124	126	646	416	130	124	128
CHHM08 - 617□DA - (B) - Ratio	0.55	4	655	416	140	148	130	698	416	140	148	133
CHHM1 - 617□DA - (B) - Ratio	0.75	4	655	416	140	148	130	698	416	140	148	133
CHHM1H - 617□DA - (B) - Ratio	1.1	4	688	416	145	160	133	750	416	145	160	138
CHHM2 - 617□DA - (B) - Ratio	1.5	4	688	416	145	160	133	750	416	145	160	138
CHHM08 - 617□DB - (B) - Ratio	0.55	4	669	416	140	148	127	712	416	140	148	134
CHHM1 - 617□DB - (B) - Ratio	0.75	4	669	416	140	148	127	712	416	140	148	134
CHHM1H - 617□DB - (B) - Ratio	1.1	4	702	416	145	160	136	764	416	145	160	141
CHHM2 - 617□DB - (B) - Ratio	1.5	4	702	416	145	160	136	764	416	145	160	141
CHHM3 - 617□DB - (B) - Ratio	2.2	4	722	416	152	173	140	785	416	152	173	146
CHHM05 - 618□DA - (B) - Ratio	0.4	4	670	451	130	124	171	702	451	130	124	173
CHHM08 - 618□DA - (B) - Ratio	0.55	4	711	451	140	148	175	754	451	140	148	178
CHHM1 - 618□DA - (B) - Ratio	0.75	4	711	451	140	148	175	754	451	140	148	178
CHHM1H - 618□DA - (B) - Ratio	1.1	4	744	451	145	160	179	806	451	145	160	184
CHHM2 - 618□DA - (B) - Ratio	1.5	4	744	451	145	160	179	806	451	145	160	184
CHHM3 - 618□DA - (B) - Ratio	2.2	4	764	451	152	173	183	827	451	152	173	189

Note: 1. □ indicates motor capacity.
 2. Dimension of shaft end diameter: Dimension tolerance conforms to JIS B 0401-1976 "h6."
 3. Dimension of shaft end key: Dimension tolerance conforms to JIS B 1301-1996 "Parallel Key."

Dimension Tables Gearmotors (Horizontal Direction, Foot-Mount)

CHHM^{Note 1} - 616□DC to 619□DA

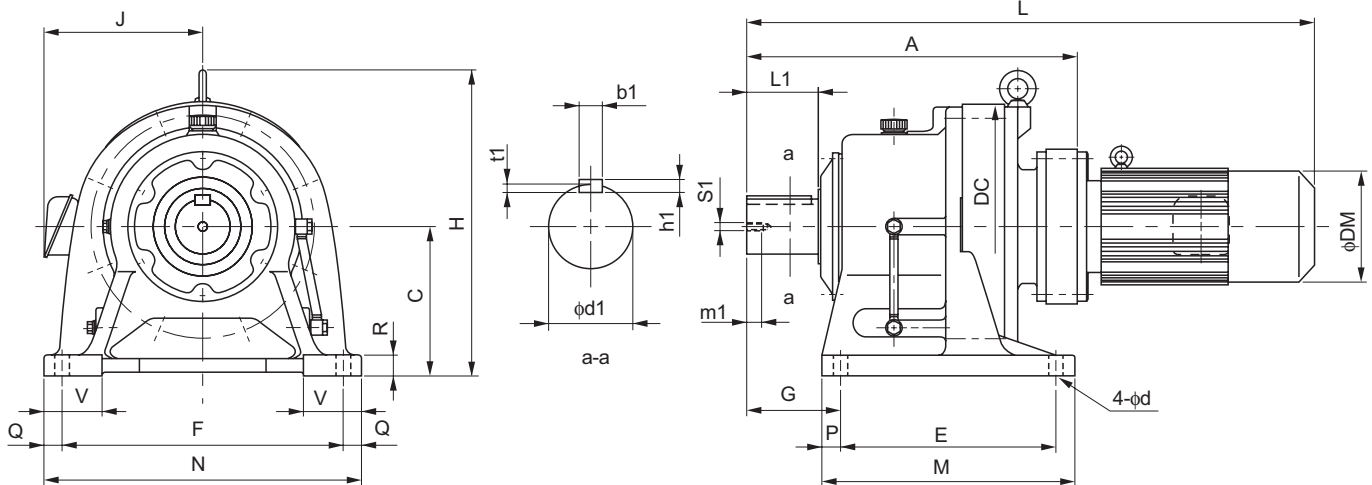

GEARMOTORS
Dimension Tables
CHHM

Frame size <small>Note 4</small>	A	C	DC	E	F	G	M	N	P	Q	R	V	d	Output Shaft <small>Note 2, 3, 6</small>						
														d1	L1	b1	h1	t1	S1	m1
616□DC	389	160	300	150	370	139	238	410	44	20	25	75	18	60	90	18	11	7	M10	18
617□DC	436	200	340	275	380	125	335	430	30	25	30	80	22	70	90	20	12	7.5	M12	24
618□DB	496	220	370	320	420	145	380	470	30	25	30	85	22	80	110	22	14	9	M12	24
619□DA	556	250	430	380	480	170	440	530	30	25	35	90	26	95	135	25	14	9	M20	34

Model <small>Note 4, 5</small>	Motor		Standard					With Brake				
	kW	P	L	H	J	DM	W(kg)	L	H	J	DM	W(kg)
CHHM1H - 616□DC - (B) - Ratio	1.1	4	659	349	145	160	107	721	349	145	160	112
CHHM2 - 616□DC - (B) - Ratio	1.5	4	659	349	145	160	107	721	349	145	160	112
CHHM3 - 616□DC - (B) - Ratio	2.2	4	679	349	152	173	111	742	349	152	173	118
CHHM4 - 616□DC - (B) - Ratio	3.0	4	702	349	168	212	121	774	349	168	212	131
CHHM5 - 616□DC - (B) - Ratio	3.7	4	702	349	168	212	121	774	349	168	212	131
CHHM8 - 616□DC - (B) - Ratio	5.5	4	746	349	168	212	128	818	349	168	212	138
CHHM1H - 617□DC - (B) - Ratio	1.1	4	706	416	145	160	141	768	416	145	160	146
CHHM2 - 617□DC - (B) - Ratio	1.5	4	706	416	145	160	141	768	416	145	160	146
CHHM3 - 617□DC - (B) - Ratio	2.2	4	726	416	152	173	145	789	416	152	173	152
CHHM4 - 617□DC - (B) - Ratio	3.0	4	749	416	168	212	155	821	416	168	212	165
CHHM5 - 617□DC - (B) - Ratio	3.7	4	749	416	168	212	155	821	416	168	212	165
CHHM8 - 617□DC - (B) - Ratio	5.5	4	793	416	168	212	162	865	416	168	212	172
CHHM1H - 618□DB - (B) - Ratio	1.1	4	766	451	145	160	194	828	451	145	160	199
CHHM2 - 618□DB - (B) - Ratio	1.5	4	766	451	145	160	194	828	451	145	160	199
CHHM3 - 618□DB - (B) - Ratio	2.2	4	786	451	152	173	197	849	451	152	173	204
CHHM4 - 618□DB - (B) - Ratio	3.0	4	809	451	168	212	207	881	451	168	212	217
CHHM5 - 618□DB - (B) - Ratio	3.7	4	809	451	168	212	207	881	451	168	212	217
CHHM8 - 618□DB - (B) - Ratio	5.5	4	853	451	168	212	214	925	451	168	212	224
CHHM10 - 618□DB - (B) - Ratio	7.5	4	876	451	213	251	229	971	451	213	251	247
CHHM15 - 618□DB - (B) - Ratio	11	4	936	451	213	251	243	1031	451	213	251	261
CHHM1 - 619□DA - (B) - Ratio	0.75	4	793	531	140	148	250	836	531	140	148	253
CHHM1H - 619□DA - (B) - Ratio	1.1	4	826	531	145	160	254	888	531	145	160	259
CHHM2 - 619□DA - (B) - Ratio	1.5	4	826	531	145	160	254	888	531	145	160	259
CHHM3 - 619□DA - (B) - Ratio	2.2	4	846	531	152	173	258	909	531	152	173	265
CHHM4 - 619□DA - (B) - Ratio	3.0	4	869	531	168	212	268	941	531	168	212	278
CHHM5 - 619□DA - (B) - Ratio	3.7	4	869	531	168	212	268	941	531	168	212	278
CHHM8 - 619□DA - (B) - Ratio	5.5	4	913	531	168	212	275	985	531	168	212	285

Note: 4. □ indicates 0 or 5, expressing combination with reduction ratio. Refer to the Selection Table for details.
 5. "B" after the frame size indicates models equipped with brake.
 6. Dimension of shaft end: Refer to pages F-28 to F-29 for details.
 7. Dimensions in above drawings are subject to change without notice.

Dimension Tables Gearmotors (Horizontal Direction, Foot-Mount)

CHHM^{Note 1} - 619□DB to 6215DA

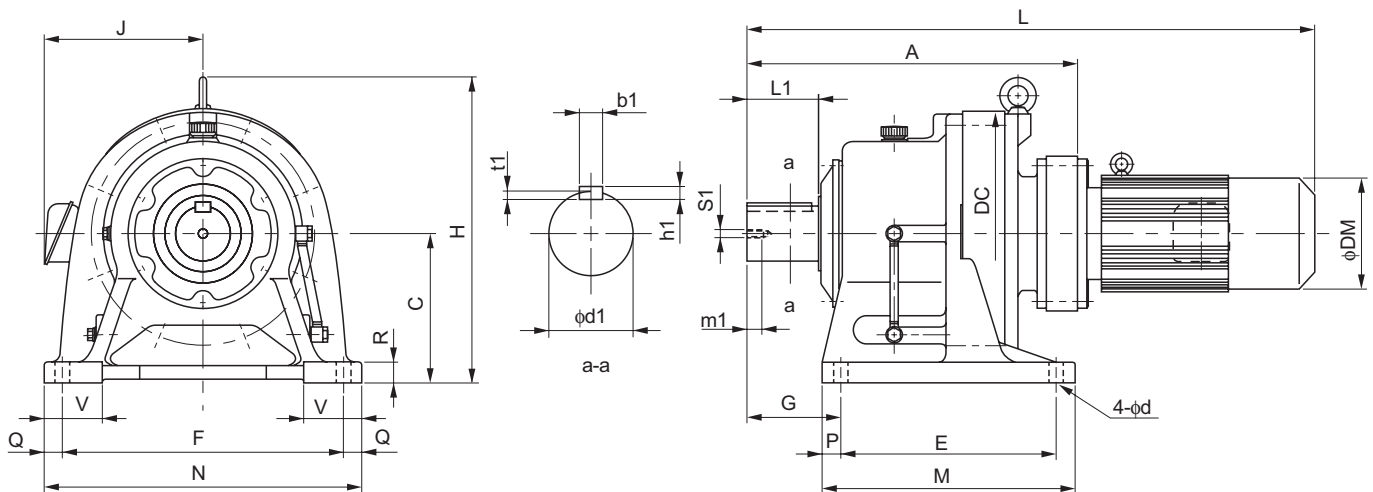

Frame size <small>Note 4</small>	A	C	DC	E	F	G	M	N	P	Q	R	V	d	Output Shaft <small>Note 2, 3, 6</small>						
														d1	L1	b1	h1	t1	S1	m1
619□DB	572	250	430	380	480	170	440	530	30	25	35	90	26	95	135	25	14	9	M20	34
6205DA	597	250	448	360	440	215	440	530	40	45	35	100	26	100	165	28	16	10	M20	34
6205DB	624	250	448	360	440	215	440	530	40	45	35	100	26	100	165	28	16	10	M20	34
6215DA	650	265	485	395	480	210	475	580	40	50	40	110	26	110	165	28	16	10	M20	34

Model <small>Note 4, 5</small>	Motor		Standard						With Brake				
	kW	P	L	H	J	DM	W(kg)	L	H	J	DM	W(kg)	
CHHM2 - 619□DB - (B) - Ratio	1.5	4	842	531	145	160	261	904	531	145	160	266	
CHHM3 - 619□DB - (B) - Ratio	2.2	4	862	531	152	173	265	925	531	152	173	272	
CHHM4 - 619□DB - (B) - Ratio	3.0	4	885	531	168	212	275	957	531	168	212	285	
CHHM5 - 619□DB - (B) - Ratio	3.7	4	885	531	168	212	275	957	531	168	212	285	
CHHM8 - 619□DB - (B) - Ratio	5.5	4	929	531	168	212	282	1001	531	168	212	292	
CHHM10 - 619□DB - (B) - Ratio	7.5	4	952	531	213	251	297	1047	531	213	251	315	
CHHM15 - 619□DB - (B) - Ratio	11	4	1012	531	213	251	311	1107	531	213	251	329	
CHHM20 - 619□DB - (B) - Ratio	15	4	1102	531	261	324	363	1207	531	261	324	397	
CHHM1 - 6205DA - (B) - Ratio	0.75	4	834	530	140	148	269	877	530	140	148	272	
CHHM2 - 6205DA - (B) - Ratio	1.5	4	867	530	145	160	273	929	530	145	160	278	
CHHM3 - 6205DA - (B) - Ratio	2.2	4	887	530	152	173	277	949	530	152	173	284	
CHHM4 - 6205DA - (B) - Ratio	3.0	4	910	530	168	212	287	982	530	168	212	297	
CHHM5 - 6205DA - (B) - Ratio	3.7	4	910	530	168	212	287	982	530	168	212	297	
CHHM8 - 6205DA - (B) - Ratio	5.5	4	954	530	168	212	294	1026	530	168	212	304	
CHHM3 - 6205DB - (B) - Ratio	2.2	4	914	530	152	173	289	977	530	152	173	296	
CHHM4 - 6205DB - (B) - Ratio	3.0	4	937	530	168	212	299	1009	530	168	212	309	
CHHM5 - 6205DB - (B) - Ratio	3.7	4	937	530	168	212	299	1009	530	168	212	309	
CHHM8 - 6205DB - (B) - Ratio	5.5	4	981	530	168	212	306	1053	530	168	212	316	
CHHM10 - 6205DB - (B) - Ratio	7.5	4	1004	530	213	251	321	1099	530	213	251	339	
CHHM15 - 6205DB - (B) - Ratio	11	4	1064	530	213	251	334	1159	530	213	251	352	
CHHM20 - 6205DB - (B) - Ratio	15	4	1154	530	261	324	386	1249	530	261	324	419	
CHHM2 - 6215DA - (B) - Ratio	1.5	4	920	575	145	160	367	982	575	145	160	372	
CHHM3 - 6215DA - (B) - Ratio	2.2	4	940	575	152	173	370	1003	575	152	173	377	
CHHM4 - 6215DA - (B) - Ratio	3.0	4	963	575	168	212	380	1035	575	168	212	390	
CHHM5 - 6215DA - (B) - Ratio	3.7	4	963	575	168	212	380	1035	575	168	212	390	
CHHM8 - 6215DA - (B) - Ratio	5.5	4	1007	575	168	212	387	1079	575	168	212	397	
CHHM10 - 6215DA - (B) - Ratio	7.5	4	1030	575	213	251	402	1125	575	213	251	420	
CHHM15 - 6215DA - (B) - Ratio	11	4	1090	575	213	251	415	1185	575	213	251	433	
CHHM20 - 6215DA - (B) - Ratio	15	4	1180	575	261	324	467	1285	575	261	324	501	

Note: 1. □ indicates motor capacity.
 2. Dimension of shaft end diameter: Dimension tolerance conforms to JIS B 0401-1976 "h6."
 3. Dimension of shaft end key: Dimension tolerance conforms to JIS B 1301-1996 "Parallel Key."

Dimension Tables Gearmotors (Horizontal Direction, Foot-Mount)

CHHM^{Note 1} - 6215DB to 6225DB

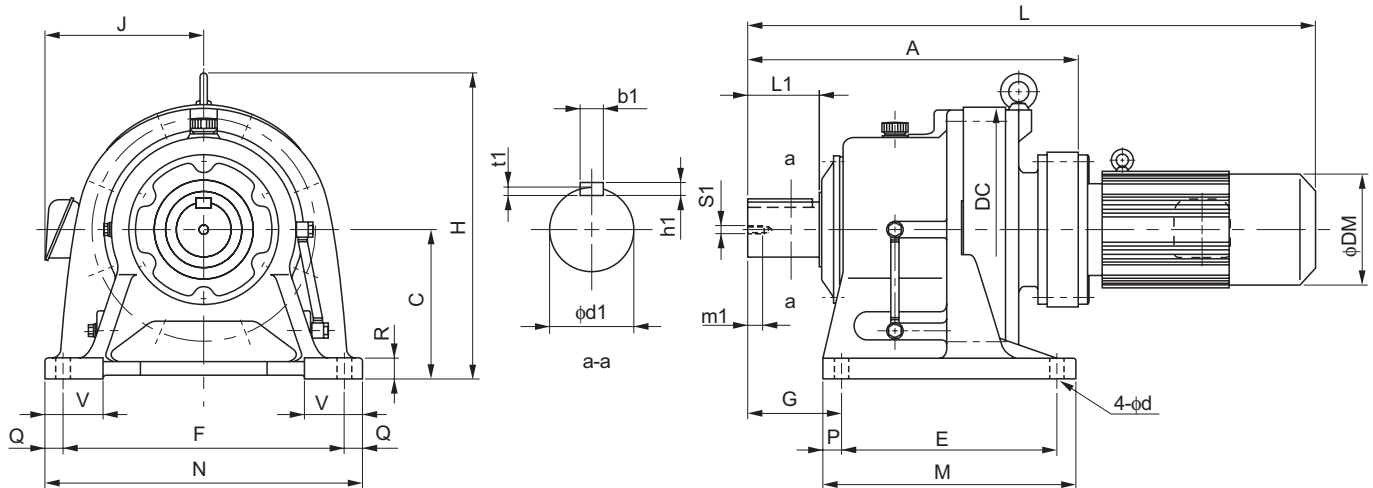

GEARMOTORS
Dimension Tables
CHHM

Frame size	A	C	DC	E	F	G	M	N	P	Q	R	V	d	Output Shaft <small>Note 2, 3, 6</small>						
														d1	L1	b1	h1	t1	S1	m1
6215DB	675	265	485	395	480	210	475	580	40	50	40	110	26	110	165	28	16	10	M20	34
6225DA	692	280	526	420	540	230	520	620	50	40	40	115	33	120	165	32	18	11	M20	34
6225DB	735	280	526	420	540	230	520	620	50	40	40	115	33	120	165	32	18	11	M20	34

Model	Note 5	Motor		Standard					With Brake				
		kW	P	L	H	J	DM	W(kg)	L	H	J	DM	W(kg)
CHHM5	-6215DB - (B) - Ratio	3.7	4	993	575	168	212	399	1065	575	168	212	409
CHHM8	-6215DB - (B) - Ratio	5.5	4	1037	575	168	212	406	1109	575	168	212	416
CHHM10	-6215DB - (B) - Ratio	7.5	4	1060	575	213	251	422	1155	575	213	251	439
CHHM15	-6215DB - (B) - Ratio	11	4	1120	575	213	251	436	1215	575	213	251	453
CHHM20	-6215DB - (B) - Ratio	15	4	1205	575	261	324	489	1310	575	261	324	523
CHHM25	-6215DB - (B) - Ratio	18.5	4	1300	575	340	394	564	1465	575	340	394	615
CHHM30	-6215DB - (B) - Ratio	22	4	1300	575	340	394	564	1465	575	340	394	615
CHHM2	-6225DA - (B) - Ratio	1.5	4	962	610	145	160	441	1024	610	145	160	446
CHHM3	-6225DA - (B) - Ratio	2.2	4	982	610	152	173	444	1045	610	152	173	451
CHHM4	-6225DA - (B) - Ratio	3.0	4	1005	610	168	212	454	1077	610	168	212	464
CHHM5	-6225DA - (B) - Ratio	3.7	4	1005	610	168	212	454	1077	610	168	212	464
CHHM8	-6225DA - (B) - Ratio	5.5	4	1049	610	168	212	461	1121	610	168	212	471
CHHM10	-6225DA - (B) - Ratio	7.5	4	1072	610	213	251	476	1167	610	213	251	494
CHHM15	-6225DA - (B) - Ratio	11	4	1132	610	213	251	490	1227	610	213	251	508
CHHM20	-6225DA - (B) - Ratio	15	4	1222	610	261	324	542	1327	610	261	324	576
CHHM5	-6225DB - (B) - Ratio	3.7	4	1058	610	168	212	499	1130	610	168	212	510
CHHM8	-6225DB - (B) - Ratio	5.5	4	1102	610	168	212	506	1174	610	168	212	517
CHHM10	-6225DB - (B) - Ratio	7.5	4	1125	610	213	251	521	1220	610	213	251	539
CHHM15	-6225DB - (B) - Ratio	11	4	1185	610	213	251	535	1280	610	213	251	553
CHHM20	-6225DB - (B) - Ratio	15	4	1265	610	261	324	589	1370	610	261	324	623
CHHM25	-6225DB - (B) - Ratio	18.5	4	1360	610	340	394	661	1525	610	340	394	712
CHHM30	-6225DB - (B) - Ratio	22	4	1360	610	340	394	661	1525	610	340	394	712
CHHM40	-6225DB - (B) - Ratio	30	4	1360	610	340	394	678	1525	610	340	394	729

Note: 4. □ indicates 0 or 5, expressing combination with reduction ratio. Refer to the Selection Table for details.
 5. "B" after the frame size indicates models equipped with brake.
 6. Dimension of shaft end: Refer to pages F-28 to F-29 for details.
 7. Dimensions in above drawings are subject to change without notice.

Dimension Tables Gearmotors (Horizontal Direction, Foot-Mount)

CHHM^{Note 1} - 6235DA to 6245DB

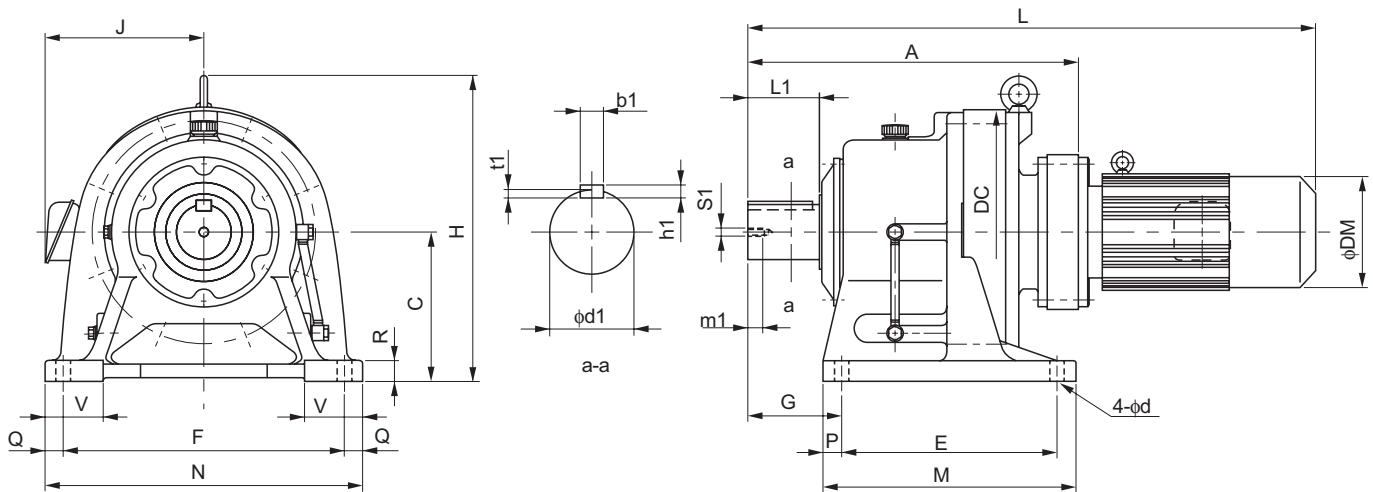

Frame size	A	C	DC	E	F	G	M	N	P	Q	R	V	d	Output Shaft ^{Note 2, 3, 5}						
														d1	L1	b1	h1	t1	S1	m1
6235DA	778	300	562	460	580	260	560	670	50	45	45	120	33	130	200	32	18	11	M24	41
6235DB	800	300	562	460	580	260	560	670	50	45	45	120	33	130	200	32	18	11	M24	41
6245DA	816	335	614	480	630	263	580	720	50	45	45	128	39	140	200	36	20	12	M24	41
6245DB	837	335	614	480	630	263	580	720	50	45	45	128	39	140	200	36	20	12	M24	41

Model	Motor ^{Note 4}	Standard							With Brake				
		kW	P	L	H	J	DM	W(kg)	L	H	J	DM	W(kg)
CHHM3 - 6235DA - (B) - Ratio	2.2 4	1068	667	152	173	561	1131	667	152	173	567		
CHHM4 - 6235DA - (B) - Ratio	3.0 4	1091	667	168	212	570	1163	667	168	212	580		
CHHM5 - 6235DA - (B) - Ratio	3.7 4	1091	667	168	212	570	1163	667	168	212	580		
CHHM8 - 6235DA - (B) - Ratio	5.5 4	1135	667	168	212	577	1207	667	168	212	587		
CHHM10 - 6235DA - (B) - Ratio	7.5 4	1163	667	213	251	593	1258	667	213	251	610		
CHHM15 - 6235DA - (B) - Ratio	11 4	1223	667	213	251	607	1318	667	213	251	624		
CHHM20 - 6235DA - (B) - Ratio	15 4	1308	667	261	324	660	1413	667	261	324	624		
CHHM25 - 6235DA - (B) - Ratio	18.5 4	1403	667	340	394	737	1568	667	340	394	788		
CHHM30 - 6235DA - (B) - Ratio	22 4	1403	667	340	394	737	1568	667	340	394	788		
CHHM15 - 6235DB - (B) - Ratio	11 4	1245	667	213	251	639	1340	667	213	251	657		
CHHM20 - 6235DB - (B) - Ratio	15 4	1330	667	261	324	701	1435	667	261	324	735		
CHHM25 - 6235DB - (B) - Ratio	18.5 4	1425	667	340	394	768	1590	667	340	394	819		
CHHM30 - 6235DB - (B) - Ratio	22 4	1425	667	340	394	768	1590	667	340	394	819		
CHHM40 - 6235DB - (B) - Ratio	30 4	1425	667	340	394	782	1590	667	340	394	825		
CHHM50 - 6235DB - (B) - Ratio	37 4	1540	667	340	394	820	1755	667	340	394	917		
CHHM3 - 6245DA - (B) - Ratio	2.2 4	1106	729	152	173	670	1169	729	152	173	676		
CHHM4 - 6245DA - (B) - Ratio	3.0 4	1129	729	168	212	679	1201	729	168	212	689		
CHHM5 - 6245DA - (B) - Ratio	3.7 4	1129	729	168	212	679	1201	729	168	212	689		
CHHM8 - 6245DA - (B) - Ratio	5.5 4	1173	729	168	212	686	1245	729	168	212	696		
CHHM10 - 6245DA - (B) - Ratio	7.5 4	1201	729	213	251	702	1296	729	213	251	719		
CHHM15 - 6245DA - (B) - Ratio	11 4	1261	729	213	251	716	1356	729	213	251	733		
CHHM20 - 6245DA - (B) - Ratio	15 4	1346	729	261	324	769	1451	729	261	324	803		
CHHM25 - 6245DA - (B) - Ratio	18.5 4	1441	729	340	394	840	1606	729	340	394	891		
CHHM30 - 6245DA - (B) - Ratio	22 4	1441	729	340	394	840	1606	729	340	394	891		
CHHM15 - 6245DB - (B) - Ratio	11 4	1282	729	213	251	740	1377	729	213	251	758		
CHHM20 - 6245DB - (B) - Ratio	15 4	1367	729	261	324	800	1472	729	261	324	834		
CHHM25 - 6245DB - (B) - Ratio	18.5 4	1462	729	340	394	866	1627	729	340	394	917		
CHHM30 - 6245DB - (B) - Ratio	22 4	1462	729	340	394	866	1627	729	340	394	917		
CHHM40 - 6245DB - (B) - Ratio	30 4	1462	729	340	394	883	1627	729	340	394	926		
CHHM50 - 6245DB - (B) - Ratio	37 4	1577	729	340	394	935	1792	729	340	394	1032		

Note: 1. □ indicates motor capacity.
 2. Dimension of shaft end diameter: Dimension tolerance conforms to JIS B 0401-1976 "h6."
 3. Dimension of shaft end key: Dimension tolerance conforms to JIS B 1301-1996 "Parallel Key."

Dimension Tables Gearmotors (Horizontal Direction, Foot-Mount)

CHHM - 6255DA to 6275DA

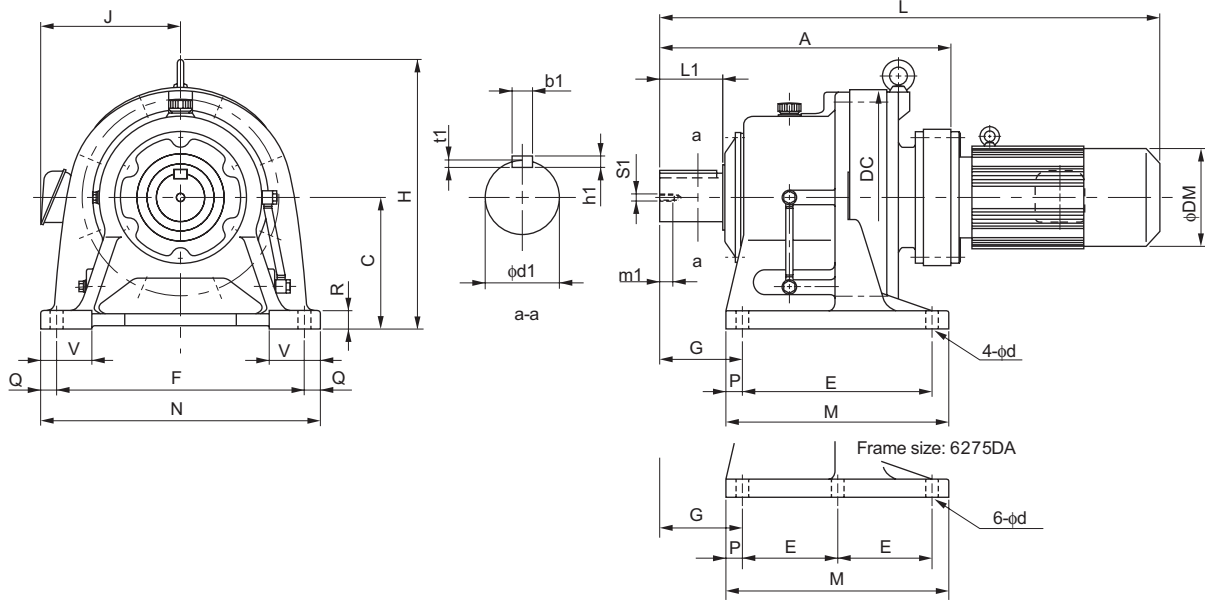

GEARMOTORS
Dimension Tables
CHHM

Frame size	A	C	DC	E	F	G	M	N	P	Q	R	V	d	Output Shaft Note 2, 3, 5						
														d1	L1	b1	h1	t1	S1	m1
6255DA	956	375	670	520	670	320	630	780	55	55	50	140	39	160	240	40	22	13	M30	49
6255DB	978	375	670	520	670	320	630	780	55	55	50	140	39	160	240	40	22	13	M30	49
6265DA	1088	400	736	590	770	390	700	880	55	55	55	160	45	170	300	40	22	13	M30	49
6275DA	1349	540	950	420	1050	485	1040	1160	100	55	60	200	45	180	330	45	25	15	M30	52

Model Note 4	Motor		Standard							With Brake				
	kW	P	L	H	J	DM	W(kg)	L	H	J	DM	W(kg)		
CHHM5 - 6255DA - (B) - Ratio	3.7	4	1284	815	168	212	1031	1356	815	168	212	1041		
CHHM8 - 6255DA - (B) - Ratio	5.5	4	1328	815	168	212	1041	1400	815	168	212	1051		
CHHM10 - 6255DA - (B) - Ratio	7.5	4	1346	815	213	251	1056	1441	815	213	251	1071		
CHHM15 - 6255DA - (B) - Ratio	11	4	1406	815	213	251	1071	1501	815	213	251	1086		
CHHM20 - 6255DA - (B) - Ratio	15	4	1486	815	261	324	1121	1591	815	261	324	1157		
CHHM25 - 6255DA - (B) - Ratio	18.5	4	1581	815	340	394	1195	1746	815	340	394	1246		
CHHM30 - 6255DA - (B) - Ratio	22	4	1581	815	340	394	1195	1746	815	340	394	1246		
CHHM40 - 6255DA - (B) - Ratio	30	4	1581	815	340	394	1215	1746	815	340	394	1258		
CHHM15 - 6255DB - (B) - Ratio	11	4	1443	815	213	251	1144	1538	815	213	251	1159		
CHHM20 - 6255DB - (B) - Ratio	15	4	1508	815	261	324	1194	1613	815	261	324	1228		
CHHM25 - 6255DB - (B) - Ratio	18.5	4	1603	815	340	394	1270	1768	815	340	394	1321		
CHHM30 - 6255DB - (B) - Ratio	22	4	1603	815	340	394	1270	1768	815	340	394	1321		
CHHM40 - 6255DB - (B) - Ratio	30	4	1603	815	340	394	1285	1768	815	340	394	1328		
CHHM50 - 6255DB - (B) - Ratio	37	4	1718	815	340	394	1323	1928	815	340	394	1420		
CHHM60 - 6255DB - (B) - Ratio	45	4	1718	815	340	394	1323	1928	815	340	394	1420		
CHHM8 - 6265DA - (B) - Ratio	5.5	4	1480	874	168	212	1366	1552	874	168	212	1376		
CHHM10 - 6265DA - (B) - Ratio	7.5	4	1493	874	213	251	1381	1588	874	213	251	1401		
CHHM15 - 6265DA - (B) - Ratio	11	4	1553	874	213	251	1396	1648	874	213	251	1411		
CHHM20 - 6265DA - (B) - Ratio	15	4	1618	874	261	324	1446	1723	874	261	324	1482		
CHHM25 - 6265DA - (B) - Ratio	18.5	4	1713	874	340	394	1525	1878	874	340	394	1570		
CHHM30 - 6265DA - (B) - Ratio	22	4	1713	874	340	394	1525	1878	874	340	394	1570		
CHHM40 - 6265DA - (B) - Ratio	30	4	1713	874	340	394	1540	1878	874	340	394	1583		
CHHM50 - 6265DA - (B) - Ratio	37	4	1828	874	340	394	1575	2043	874	340	394	1672		
CHHM60 - 6265DA - (B) - Ratio	45	4	1828	874	340	394	1575	2043	874	340	394	1672		
CHHM10 - 6275DA - (B) - Ratio	7.5	4	1754	1161	213	251	2516	1849	1161	213	251	2536		
CHHM15 - 6275DA - (B) - Ratio	11	4	1814	1161	213	251	2531	1909	1161	213	251	2546		
CHHM20 - 6275DA - (B) - Ratio	15	4	1879	1161	261	324	2581	1984	1161	261	324	2617		
CHHM25 - 6275DA - (B) - Ratio	18.5	4	1974	1161	340	394	2660	2139	1161	340	394	2705		
CHHM30 - 6275DA - (B) - Ratio	22	4	1974	1161	340	394	2660	2139	1161	340	394	2705		
CHHM40 - 6275DA - (B) - Ratio	30	4	1974	1161	340	394	2670	2139	1161	340	394	2718		
CHHM50 - 6275DA - (B) - Ratio	37	4	2089	1161	340	394	2715	2304	1161	340	394	2810		
CHHM60 - 6275DA - (B) - Ratio	45	4	2089	1161	340	394	2715	2304	1161	340	394	2810		

Note: 4. "B" after the frame size indicates models equipped with brake.
 5. Dimension of shaft end: Refer to pages F-28 to F-29 for details.
 6. Dimensions in above drawings are subject to change without notice.

Dimension Tables Gearmotors (Universal Direction, Flange Mount)

CNFM^{Note 1} - 606□ to 609□

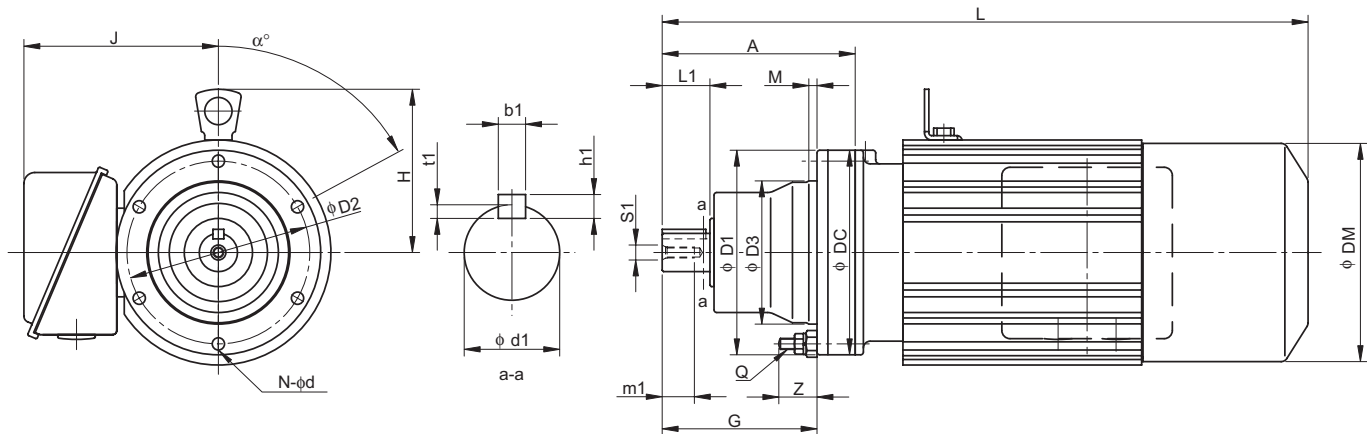

Frame size <small>Note 5</small>	A	G	D1	D2	D3	DC	Q	Z	M	N	d	α°	Output Shaft <small>Note 2, 3, 7</small>						
													d1	L1	b1	h1	t1	S1	m1
606□	92	68	110	98	80	110	M6	21	4	6	6.6	60	14	25	5	5	3	M5	16
607□	98	74	110	98	80	110	M6	21	4	6	6.6	60	18	30	6	6	3.5	M6	16
608□	129	91	134	118	95	134	M8	27	5	8	9	22.5	22	35	6	6	3.5	M6	16
609□	142	114	150	134	105	150	M8	28	6	8	9	22.5	28	35	8	7	4	M8	20

Model <small>Note 5, 6</small>	Motor		Standard					With Brake				
	kW	P	L	H	J	DM	W(kg)	L	H	J	DM	W(kg)
CNFM01 - 606□ - (B) - Ratio	0.1	4	254	-	130	119	6.5	261	-	130	124	8
CNFM02 - 606□ - (B) - Ratio	0.2	4	272	-	130	124	7.5	300	-	130	124	9
CNFM03 - 606□ - (B) - Ratio	0.25	4	272	-	130	124	7.5	300	-	130	124	9
CNFM01 - 607□ - (B) - Ratio	0.1	4	260	-	130	119	7.5	267	-	130	124	8.5
CNFM02 - 607□ - (B) - Ratio	0.2	4	278	-	130	124	8.5	306	-	130	124	9.5
CNFM03 - 607□ - (B) - Ratio	0.25	4	278	-	130	124	8.5	306	-	130	124	9.5
CNFM05 - 607□ - (B) - Ratio	0.4	4	294	-	130	124	9.5	326	-	130	124	10.5
CNFM01 - 608□ - (B) - Ratio	0.1	4	286	-	130	119	10	293	-	130	124	11
CNFM02 - 608□ - (B) - Ratio	0.2	4	304	-	130	124	11	332	-	130	124	12
CNFM03 - 608□ - (B) - Ratio	0.25	4	304	-	130	124	11	332	-	130	124	12
CNFM05 - 608□ - (B) - Ratio	0.4	4	320	-	130	124	13	352	-	130	124	14
CNFM08 - 608□ - (B) - Ratio	0.55	4	361	113	140	148	17	404	113	140	148	18
CNFM1 - 608□ - (B) - Ratio	0.75	4	361	113	140	148	17	404	113	140	148	18
CNFM01 - 609□ - (B) - Ratio	0.1	4	304	-	130	119	11	311	-	130	124	13
CNFM02 - 609□ - (B) - Ratio	0.2	4	322	-	130	124	12	350	-	130	124	14
CNFM03 - 609□ - (B) - Ratio	0.25	4	322	-	130	124	12	350	-	130	124	14
CNFM05 - 609□ - (B) - Ratio	0.4	4	338	-	130	124	13	370	-	130	124	15
CNFM08 - 609□ - (B) - Ratio	0.55	4	379	113	140	148	17	422	113	140	148	19
CNFM1 - 609□ - (B) - Ratio	0.75	4	379	113	140	148	17	422	113	140	148	19
CNFM1H - 609□ - (B) - Ratio	1.1	4	412	120	145	160	21	474	120	145	160	25
CNFM2 - 609□ - (B) - Ratio	1.5	4	412	120	145	160	21	474	120	145	160	25

- Note: 1. □ indicates motor capacity.
 2. Dimension of shaft end diameter: Dimension tolerance conforms to JIS B 0401-1976 "h6."
 3. Dimension of shaft end key: Dimension tolerance conforms to JIS B 1301-1996 "Parallel Key."
 4. Pilot diameter ($\phi D3$): Dimension tolerance conforms to JIS B 0401-1976 "g6."

Dimension Tables Gearmotors (Universal Direction, Flange Mount)

CNFM^{Note 1} - 610□ to 612□

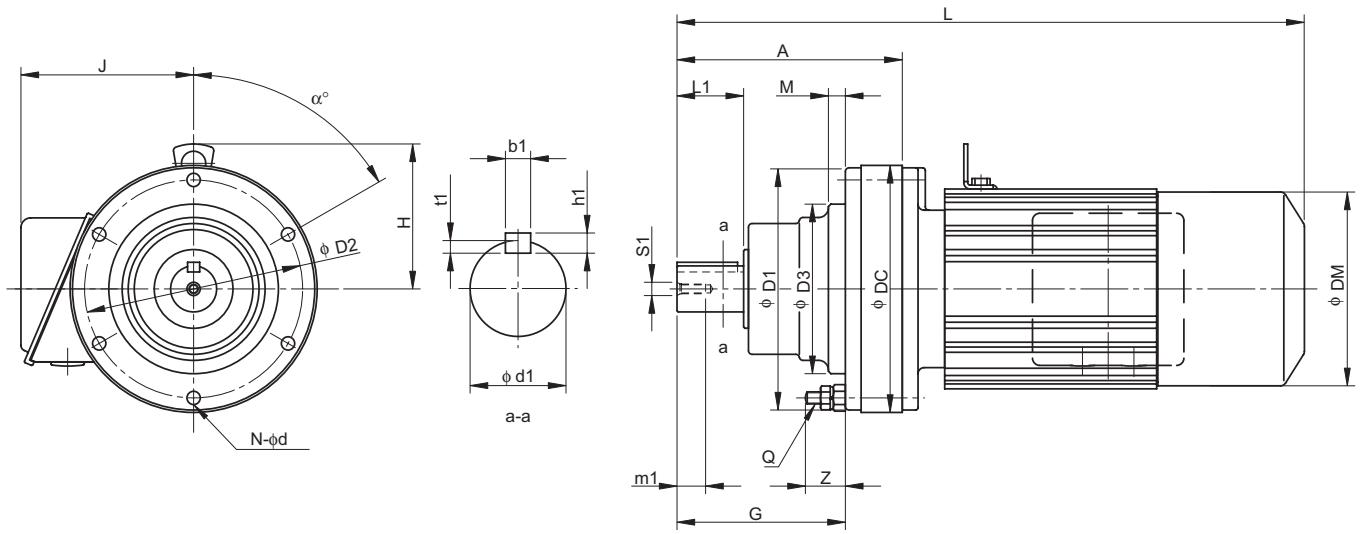

GEARMOTORS
Dimension Tables
CNFM

Frame size <small>Note 5</small>	A	G	D1	D2	D3	DC	Q	Z	M	N	d	α°	Output Shaft <small>Note 2, 3, 7</small>						
													d1	L1	b1	h1	t1	S1	m1
610□	156	114	150	134	105	150	M8	28	6	8	9	22.5	28	35	8	7	4	M8	20
611□	170	118	162	146	115	162	M8	28	6	8	9	22.5	32	45	10	8	5	M8	20
612□	186	139	200	180	140	204	M10	33	14	6	11	60	38	55	10	8	5	M8	20

Model <small>Note 5, 6</small>	Motor		Standard					With Brake				
	kW	P	L	H	J	DM	W(kg)	L	H	J	DM	W(kg)
CNFM02 - 610□ - (B) - Ratio	0.2	4	336	-	130	124	14	364	-	130	124	16
CNFM03 - 610□ - (B) - Ratio	0.25	4	336	-	130	124	14	364	-	130	124	16
CNFM05 - 610□ - (B) - Ratio	0.4	4	352	-	130	124	15	384	-	130	124	17
CNFM08 - 610□ - (B) - Ratio	0.55	4	393	113	140	148	19	436	113	140	148	22
CNFM1 - 610□ - (B) - Ratio	0.75	4	393	113	140	148	19	436	113	140	148	22
CNFM1H - 610□ - (B) - Ratio	1.1	4	426	120	145	160	23	488	120	145	160	28
CNFM2 - 610□ - (B) - Ratio	1.5	4	426	120	145	160	23	488	120	145	160	28
CNFM3 - 610□ - (B) - Ratio	2.2	4	446	126	152	173	27	509	126	152	173	33
CNFM05 - 611□ - (B) - Ratio	0.4	4	363	-	130	124	17	394	-	130	124	18
CNFM08 - 611□ - (B) - Ratio	0.55	4	403	113	140	148	20	452	113	140	148	23
CNFM1 - 611□ - (B) - Ratio	0.75	4	403	113	140	148	20	452	113	140	148	23
CNFM1H - 611□ - (B) - Ratio	1.1	4	436	120	145	160	23	493	120	145	160	28
CNFM2 - 611□ - (B) - Ratio	1.5	4	436	120	145	160	23	493	120	145	160	28
CNFM3 - 611□ - (B) - Ratio	2.2	4	456	126	152	173	27	519	126	152	173	33
CNFM4 - 611□ - (B) - Ratio	3.0	4	491	146	168	212	37	563	146	168	212	47
CNFM5 - 611□ - (B) - Ratio	3.7	4	491	146	168	212	37	563	146	168	212	47
CNFM05 - 612□ - (B) - Ratio	0.4	4	387	113	130	124	26	419	113	130	124	28
CNFM08 - 612□ - (B) - Ratio	0.55	4	423	113	140	148	28	466	113	140	148	31
CNFM1 - 612□ - (B) - Ratio	0.75	4	423	113	140	148	28	466	113	140	148	31
CNFM1H - 612□ - (B) - Ratio	1.1	4	456	120	145	160	32	518	120	145	160	37
CNFM2 - 612□ - (B) - Ratio	1.5	4	456	120	145	160	32	518	120	145	160	37
CNFM3 - 612□ - (B) - Ratio	2.2	4	476	126	152	173	36	539	126	152	173	43
CNFM4 - 612□ - (B) - Ratio	3.0	4	499	146	168	212	46	571	146	168	212	56
CNFM5 - 612□ - (B) - Ratio	3.7	4	499	146	168	212	46	571	146	168	212	56
CNFM8 - 612□ - (B) - Ratio	5.5	4	543	146	168	212	53	615	146	168	212	63

Note: 5. □ indicates 0 or 5, expressing combination with reduction ratio. Refer to the Selection Table for details.
 6. "B" after the frame size indicates models equipped with brake.
 7. Dimension of shaft end: Refer to pages F-28 to F-29 for details.
 8. Dimensions in above drawings are subject to change without notice.

Dimension Tables Gearmotors (Horizontal Direction, Flange Mount)

CHFM^{Note 1} - 613□ to 614□

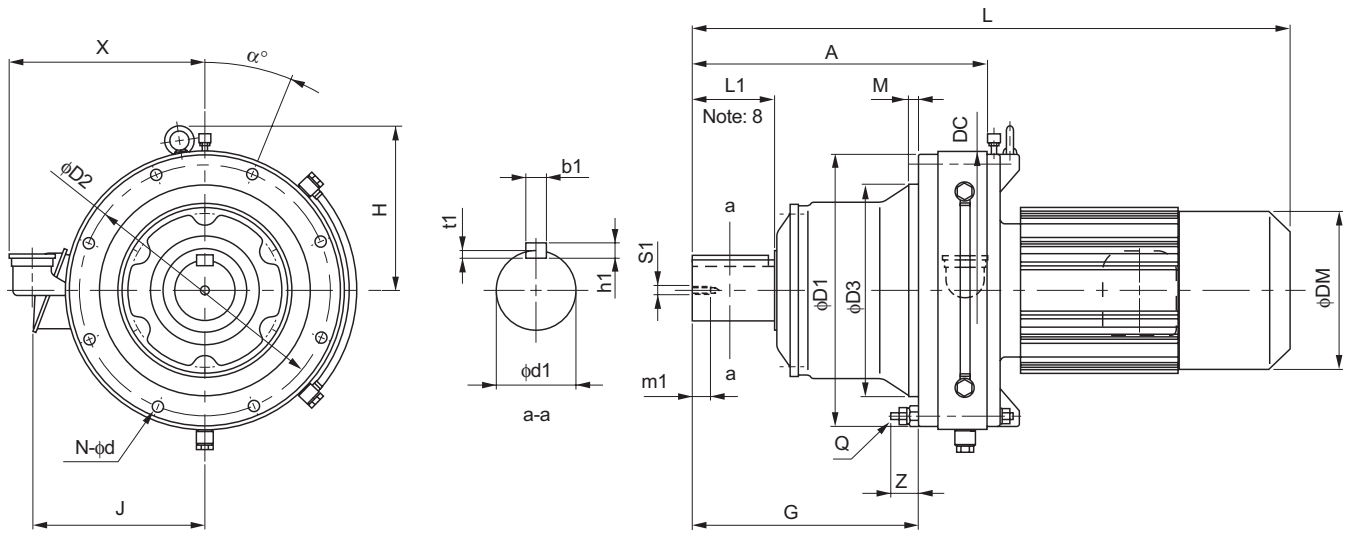

Frame size <small>Note 5</small>	A	G	D1	D2	D3	DC	Q	Z	M	N	d	α°	X	Output Shaft <small>Note 2, 3, 7</small>						
														d1	L1	b1	h1	t1	S1	m1
613□	240	178	226	205	165	230	M10	31	16	6	11	60	208	50	70	14	9	5.5	M10	18
614□	260	198	226	205	165	230	M10	31	16	6	11	60	208	50	90	14	9	5.5	M10	18

Model <small>Note 5, 6</small>	Motor		Standard						With Brake					
	kW	P	L	H	J	DM	W(kg)	L	H	J	DM	W(kg)		
CHFM08 - 613□	- (B)	- Ratio	0.55	4	477	111	140	148	44	520	111	140	148	46
CHFM1 - 613□	- (B)	- Ratio	0.75	4	477	111	140	148	44	520	111	140	148	47
CHFM1H - 613□	- (B)	- Ratio	1.1	4	510	118	145	160	48	572	118	145	160	53
CHFM2 - 613□	- (B)	- Ratio	1.5	4	510	118	145	160	48	572	118	145	160	53
CHFM3 - 613□	- (B)	- Ratio	2.2	4	530	124	152	173	51	593	124	152	173	58
CHFM4 - 613□	- (B)	- Ratio	3.0	4	553	146	168	212	61	625	146	168	212	71
CHFM5 - 613□	- (B)	- Ratio	3.7	4	553	146	168	212	61	625	146	168	212	71
CHFM8 - 613□	- (B)	- Ratio	5.5	4	597	146	168	212	68	669	146	168	212	78
CHFM10 - 613□	- (B)	- Ratio	7.5	4	620	173	213	251	83	715	173	213	251	101
CHFM15 - 613□	- (B)	- Ratio	11	4	680	173	213	251	97	775	173	213	251	115
CHFM1 - 614□	- (B)	- Ratio	0.75	4	497	118	140	148	45	540	118	140	148	48
CHFM1H - 614□	- (B)	- Ratio	1.1	4	530	118	145	160	49	592	118	145	160	54
CHFM2 - 614□	- (B)	- Ratio	1.5	4	530	118	145	160	49	592	118	145	160	54
CHFM3 - 614□	- (B)	- Ratio	2.2	4	550	124	152	173	52	613	124	152	173	59
CHFM4 - 614□	- (B)	- Ratio	3.0	4	573	146	168	212	62	645	146	168	212	72
CHFM5 - 614□	- (B)	- Ratio	3.7	4	573	146	168	212	62	645	146	168	212	72
CHFM8 - 614□	- (B)	- Ratio	5.5	4	617	146	168	212	69	689	146	168	212	79
CHFM10 - 614□	- (B)	- Ratio	7.5	4	640	173	213	251	84	735	173	213	251	102
CHFM15 - 614□	- (B)	- Ratio	11	4	700	173	213	251	98	795	173	213	251	116
CHFM20 - 614□	- (B)	- Ratio	15	4	790	208	261	324	150	895	208	261	324	184

- Note: 1. □ indicates motor capacity.
 2. Dimension of shaft end diameter: Dimension tolerance conforms to JIS B 0401-1976 "h6."
 3. Dimension of shaft end key: Dimension tolerance conforms to JIS B 1301-1996 "Parallel Key."
 4. Pilot diameter (φD3): Dimension tolerance conforms to JIS B 0401-1976 "g6."

Dimension Tables Gearmotors (Horizontal Direction, Flange Mount)

CHFM^{Note 1} - 616□ to 617□

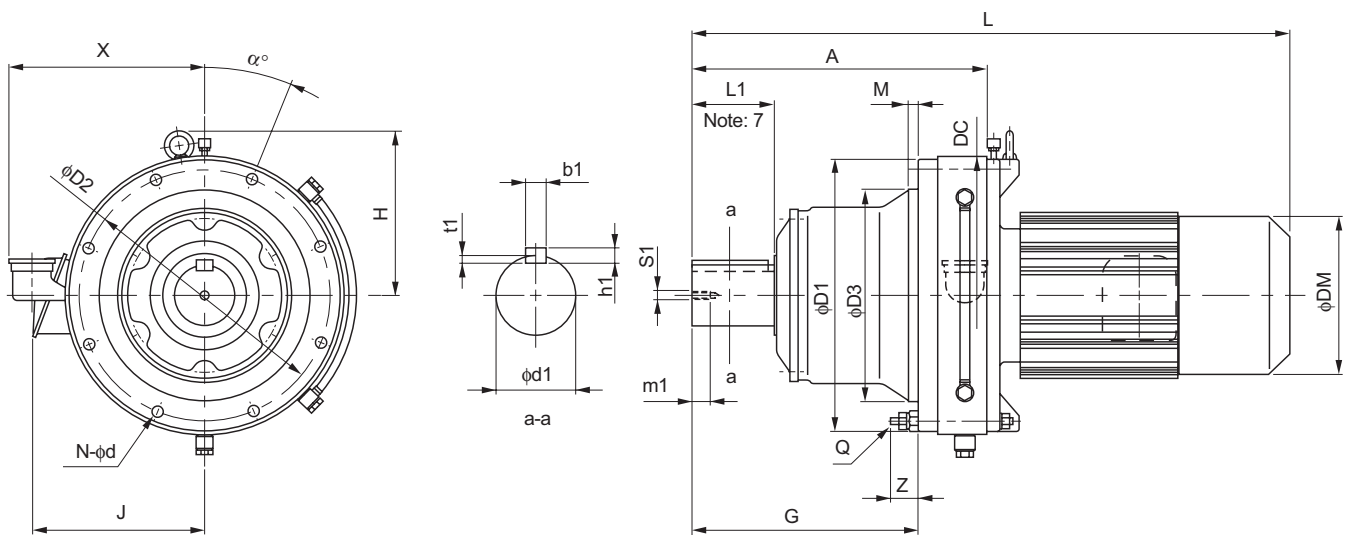

GEARMOTORS
Dimension Tables
CHFM

Frame size <small>Note 5</small>	A	G	D1	D2	D3	DC	Q	Z	M	N	d	α°	X	Output Shaft <small>Note 2, 3, 7</small>						
														d1	L1	b1	h1	t1	S1	m1
616□	308	222	296	270	200	300	M12	35	10	6	14	30	228	60	90	18	11	7	M10	18
617□	352	262	330	300	250	340	M12	41	12	8	14	22.5	243	70	90	20	12	7.5	M12	24

Model <small>Note 5, 6</small>	Motor		Standard					With Brake					
	kW	P	L	H	J	DM	W(kg)	L	H	J	DM	W(kg)	
CHFM1H - 616□	- (B) - Ratio	1.1	4	583	118	145	160	76	645	118	145	160	81
CHFM2 - 616□	- (B) - Ratio	1.5	4	583	118	145	160	76	645	118	145	160	81
CHFM3 - 616□	- (B) - Ratio	2.2	4	598	124	152	173	79	661	124	152	173	85
CHFM4 - 616□	- (B) - Ratio	3.0	4	621	146	168	212	88	693	146	168	212	98
CHFM5 - 616□	- (B) - Ratio	3.7	4	621	146	168	212	88	693	146	168	212	98
CHFM8 - 616□	- (B) - Ratio	5.5	4	665	146	168	212	95	737	146	168	212	105
CHFM10 - 616□	- (B) - Ratio	7.5	4	693	173	213	251	111	788	173	213	251	128
CHFM15 - 616□	- (B) - Ratio	11	4	753	173	213	251	125	848	173	213	251	142
CHFM20 - 616□	- (B) - Ratio	15	4	838	208	261	324	178	943	208	261	324	212
CHFM25 - 616□	- (B) - Ratio	18.5	4	933	208	340	394	254	1098	208	340	394	305
CHFM30 - 616□	- (B) - Ratio	22	4	933	208	340	394	254	1098	208	340	394	305
CHFM4 - 617□	- (B) - Ratio	3.0	4	680	203	168	212	119	752	203	168	212	129
CHFM5 - 617□	- (B) - Ratio	3.7	4	680	203	168	212	119	752	203	168	212	129
CHFM8 - 617□	- (B) - Ratio	5.5	4	724	203	168	212	126	796	203	168	212	136
CHFM10 - 617□	- (B) - Ratio	7.5	4	742	203	213	251	141	837	203	213	251	159
CHFM15 - 617□	- (B) - Ratio	11	4	802	203	213	251	155	897	203	213	251	173
CHFM20 - 617□	- (B) - Ratio	15	4	882	213	261	324	209	987	213	261	324	243
CHFM25 - 617□	- (B) - Ratio	18.5	4	977	227	340	394	281	1142	227	340	394	332
CHFM30 - 617□	- (B) - Ratio	22	4	977	227	340	394	281	1142	227	340	394	332
CHFM40 - 617□	- (B) - Ratio	30	4	977	228	340	394	298	1142	228	340	394	341

Note: 5. □ indicates 0 or 5, expressing combination with reduction ratio. Refer to the Selection Table for details.
 6. "B" after the frame size indicates models equipped with brake.
 7. Dimension of shaft end: Refer to pages F-28 to F-29 for details.
 8. Dimensions in above drawings are subject to change without notice.

Dimension Tables Gearmotors (Horizontal Direction, Flange Mount)

CHFM^{Note 1} - 618□ to 619□

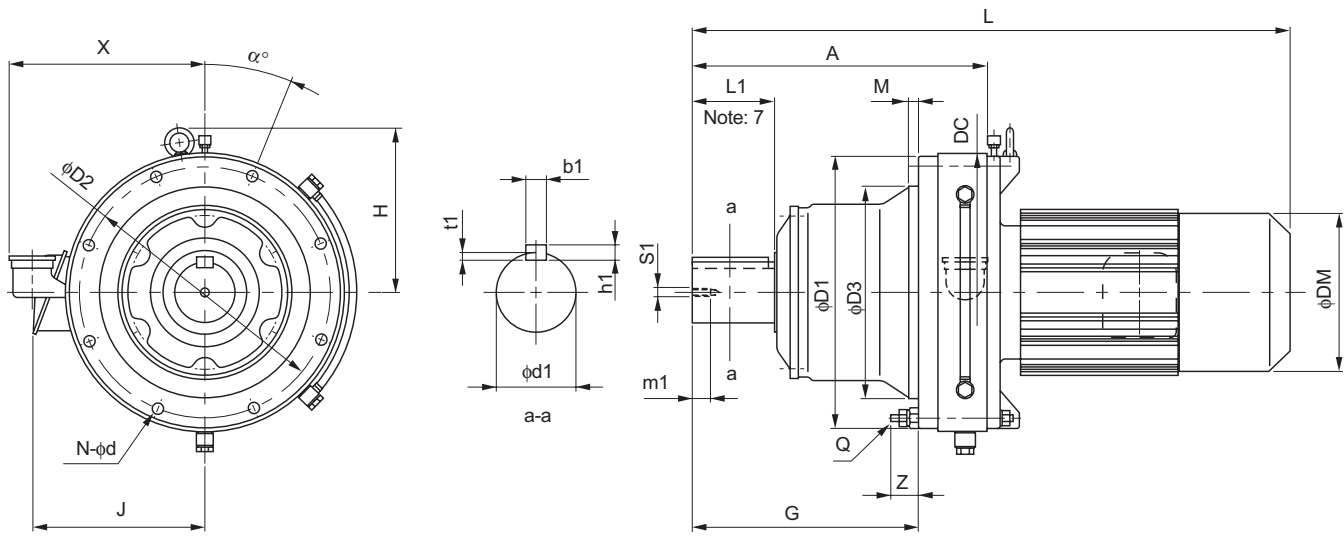

Frame size <small>Note 5</small>	A	G	D1	D2	D3	DC	Q	Z	M	N	d	α°	X	Output Shaft <small>Note 2, 3, 7</small>						
														d1	L1	b1	h1	t1	S1	m1
618□	389	299	360	330	280	370	M12	38	12	8	14	22.5	258	80	110	22	14	9	M12	24
619□	465	365	420	380	320	430	M12	41	10	12	14	15	285	95	135	25	14	9	M20	34

Model <small>Note 5, 6</small>	Motor		Standard						With Brake					
	kW	P	L	H	J	DM	W(kg)	L	H	J	DM	W(kg)		
CHFM4 - 618□	- (B)	- Ratio	3.0	4	717	218	168	212	149	789	218	168	212	159
CHFM5 - 618□	- (B)	- Ratio	3.7	4	717	218	168	212	149	789	218	168	212	159
CHFM8 - 618□	- (B)	- Ratio	5.5	4	761	218	168	212	157	833	218	168	212	167
CHFM10 - 618□	- (B)	- Ratio	7.5	4	779	218	213	251	172	874	218	213	251	190
CHFM15 - 618□	- (B)	- Ratio	11	4	839	218	213	251	186	934	218	213	251	204
CHFM20 - 618□	- (B)	- Ratio	15	4	919	217	261	324	246	1024	217	261	324	275
CHFM25 - 618□	- (B)	- Ratio	18.5	4	1014	227	340	394	312	1179	227	340	394	363
CHFM30 - 618□	- (B)	- Ratio	22	4	1014	227	340	394	312	1179	227	340	394	363
CHFM40 - 618□	- (B)	- Ratio	30	4	1014	228	340	394	329	1179	228	340	394	372
CHFM50 - 618□	- (B)	- Ratio	37	4	1129	228	340	394	377	1344	228	340	394	474
CHFM60 - 618□	- (B)	- Ratio	45	4	1129	228	340	394	377	1344	228	340	394	474
CHFM8 - 619□	- (B)	- Ratio	5.5	4	857	261	168	212	217	929	261	168	212	227
CHFM10 - 619□	- (B)	- Ratio	7.5	4	870	261	213	251	230	965	261	213	251	248
CHFM15 - 619□	- (B)	- Ratio	11	4	930	261	213	251	244	1025	261	213	251	262
CHFM20 - 619□	- (B)	- Ratio	15	4	995	217	261	324	297	1100	217	261	324	332
CHFM25 - 619□	- (B)	- Ratio	18.5	4	1090	227	340	394	373	1255	227	340	394	418
CHFM256 - 619□	- (B)	- Ratio	18.5	6	1090	227	340	394	388	1255	227	340	394	431
CHFM30 - 619□	- (B)	- Ratio	22	4	1090	227	340	394	373	1255	227	340	394	418
CHFM40 - 619□	- (B)	- Ratio	30	4	1090	261	340	394	388	1255	261	340	394	431
CHFM406 - 619□	- (B)	- Ratio	30	6	1205	261	340	394	426	1420	261	340	394	523
CHFM50 - 619□	- (B)	- Ratio	37	4	1205	261	340	394	426	1420	261	340	394	523
CHFM506 - 619□	- (B)	- Ratio	37	6	1205	261	340	394	426	1420	261	340	394	523
CHFM60 - 619□	- (B)	- Ratio	45	4	1205	261	340	394	426	1420	261	340	394	523

- Note: 1. □ indicates motor capacity.
 2. Dimension of shaft end diameter: Dimension tolerance conforms to JIS B 0401-1976 "h6."
 3. Dimension of shaft end key: Dimension tolerance conforms to JIS B 1301-1996 "Parallel Key."
 4. Pilot diameter (φD3): Dimension tolerance conforms to JIS B 0401-1976 "g6."

Dimension Tables Gearmotors (Horizontal Direction, Flange Mount)

CHFM^{Note 1} - 6205 to 6215

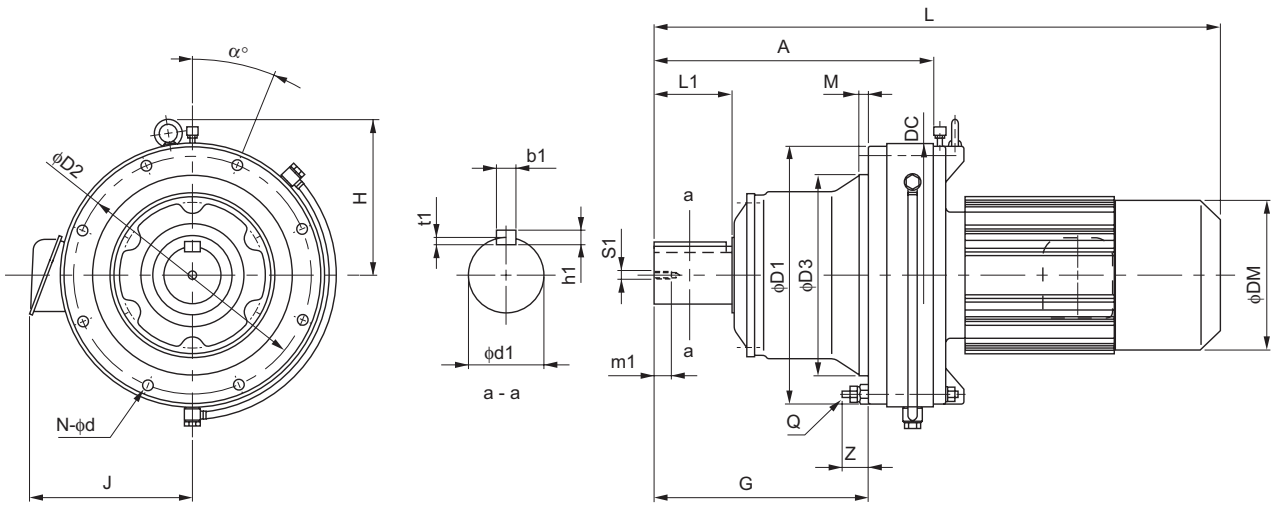

Dimension Tables
CHFM
GEARMOTORS

Frame size	A	G	D1	D2	D3	DC	Q	Z	M	N	d	α°	Output Shaft ^{Note 2, 3, 7}						
													d1	L1	b1	h1	t1	S1	m1
6205	502	410	443	405	360	448	M16	57	20	12	18	15	100	165	28	16	10	M20	34
6215	526	423	480	440	390	485	M18	57	20	12	20.5	15	110	165	28	16	10	M20	34

Model ^{Note 6}	Motor		Standard						With Brake				
	kW	P	L	H	J	DM	W(kg)	L	H	J	DM	W(kg)	
CHFM15 -6205	- (B) - Ratio	11	4	972	283	213	251	270	1067	283	213	251	288
CHFM20 -6205	- (B) - Ratio	15	4	1042	283	261	324	324	1147	283	261	324	360
CHFM206 -6205	- (B) - Ratio	15	6	1127	283	340	394	399	1292	283	340	394	444
CHFM25 -6205	- (B) - Ratio	18.5	4	1127	283	340	394	399	1292	283	340	394	444
CHFM30 -6205	- (B) - Ratio	22	4	1127	283	340	394	399	1292	283	340	394	444
CHFM306 -6205	- (B) - Ratio	22	6	1127	283	340	394	412	1292	283	340	394	457
CHFM40 -6205	- (B) - Ratio	30	4	1127	283	340	394	412	1292	283	340	394	457
CHFM406 -6205	- (B) - Ratio	30	6	1242	283	340	394	450	1457	283	340	394	544
CHFM50 -6205	- (B) - Ratio	37	4	1242	283	340	394	450	1457	283	340	394	544
CHFM506 -6205	- (B) - Ratio	37	6	1242	283	340	394	450	1457	283	340	394	544
CHFM60 -6205	- (B) - Ratio	45	4	1242	283	340	394	450	1457	283	340	394	544
CHFM606 -6205	- (B) - Ratio	45	6	1297	283	390	484	543	-	283	-	-	-
CHFM75 -6205	- (B) - Ratio	55	4	1297	283	390	484	543	-	283	-	-	-
CHFM15 -6215	- (B) - Ratio	11	4	996	312	213	251	350	1091	312	213	251	368
CHFM20 -6215	- (B) - Ratio	15	4	1066	312	261	324	405	1171	312	261	324	440
CHFM206 -6215	- (B) - Ratio	15	6	1151	312	340	394	474	1316	312	340	394	519
CHFM25 -6215	- (B) - Ratio	18.5	4	1151	312	340	394	474	1316	312	340	394	519
CHFM256 -6215	- (B) - Ratio	18.5	6	1151	312	340	394	487	1316	312	340	394	532
CHFM30 -6215	- (B) - Ratio	22	4	1151	312	340	394	474	1316	312	340	394	519
CHFM306 -6215	- (B) - Ratio	22	6	1151	312	340	394	487	1316	312	340	394	532
CHFM40 -6215	- (B) - Ratio	30	4	1151	312	340	394	487	1316	312	340	394	532
CHFM406 -6215	- (B) - Ratio	30	6	1266	312	340	394	525	1481	312	340	394	620
CHFM50 -6215	- (B) - Ratio	37	4	1266	312	340	394	525	1481	312	340	394	620
CHFM506 -6215	- (B) - Ratio	37	6	1266	312	340	394	525	1481	312	340	394	620
CHFM60 -6215	- (B) - Ratio	45	4	1266	312	340	394	525	1481	312	340	394	620
CHFM606 -6215	- (B) - Ratio	45	6	1321	312	390	484	635	-	312	-	-	-
CHFM75 -6215	- (B) - Ratio	55	4	1321	312	390	484	635	-	312	-	-	-

Note: 5. □ indicates 0 or 5, expressing combination with reduction ratio. Refer to the Selection Table for details.
 6. "B" after the frame size indicates models equipped with brake.
 7. Dimension of shaft end: Refer to pages F-28 to F-29 for details.
 8. Dimensions in above drawings are subject to change without notice.

Dimension Tables Gearmotors (Horizontal Direction, Flange Mount)

CHFM^{Note 1} - 6225 to 6235

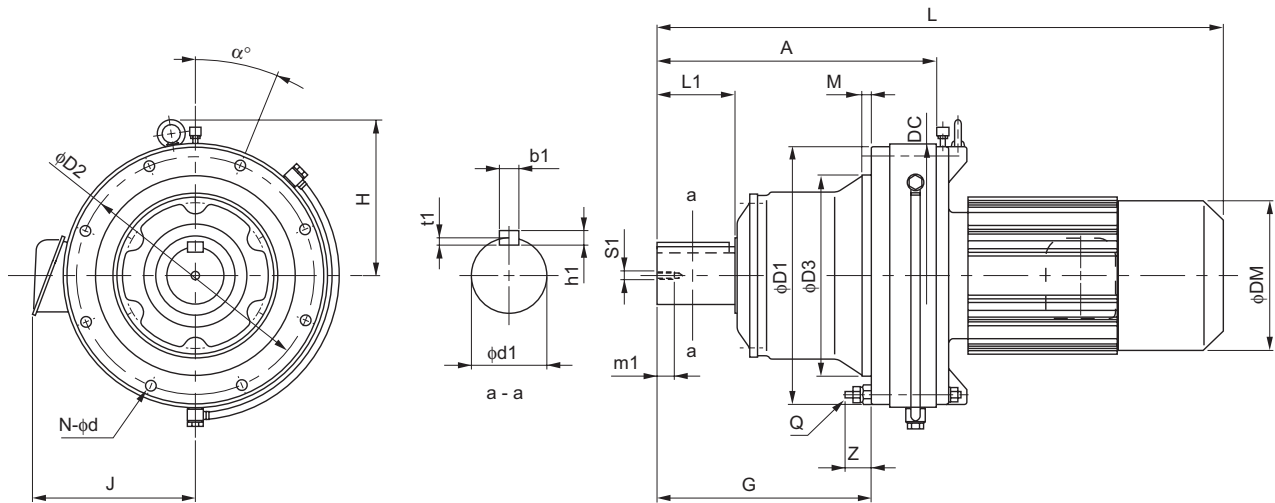

GEARMOTORS

Dimension Tables
CHFM

Frame size	A	G	D1	D2	D3	DC	Q	Z	M	N	d	α°	Output Shaft <small>Note 2, 3, 6</small>						
													d1	L1	b1	h1	t1	S1	m1
6225	566	454	521	475	420	526	M20	60	20	12	22	15	120	165	32	18	11	M20	34
6235	628	505	557	510	455	562	M20	63	20	12	22	15	130	200	32	18	11	M24	41

Model	Note 5	Motor		Standard					With Brake				
		kW	P	L	H	J	DM	W(kg)	L	H	J	DM	W(kg)
CHFM206 - 6225	-(B) - Ratio	15	6	1191	333	340	394	542	1356	333	340	394	587
CHFM25 - 6225	-(B) - Ratio	18.5	4	1191	333	340	394	542	1356	333	340	394	587
CHFM256 - 6225	-(B) - Ratio	18.5	6	1191	333	340	394	555	1356	333	340	394	600
CHFM30 - 6225	-(B) - Ratio	22	4	1191	333	340	394	542	1356	333	340	394	587
CHFM306 - 6225	-(B) - Ratio	22	6	1191	333	340	394	555	1356	333	340	394	600
CHFM40 - 6225	-(B) - Ratio	30	4	1191	333	340	394	555	1356	333	340	394	600
CHFM406 - 6225	-(B) - Ratio	30	6	1306	333	340	394	593	1521	333	340	394	688
CHFM50 - 6225	-(B) - Ratio	37	4	1306	333	340	394	593	1521	333	340	394	688
CHFM506 - 6225	-(B) - Ratio	37	6	1306	333	340	394	593	1521	333	340	394	688
CHFM60 - 6225	-(B) - Ratio	45	4	1306	333	340	394	593	1521	333	340	394	688
CHFM606 - 6225	-(B) - Ratio	45	6	1361	333	390	484	692	-	-	-	-	-
CHFM75 - 6225	-(B) - Ratio	55	4	1361	333	390	484	692	-	-	-	-	-
CHFM206 - 6235	-(B) - Ratio	15	6	1253	351	340	394	627	1463	351	340	394	658
CHFM256 - 6235	-(B) - Ratio	18.5	6	1253	351	340	394	627	1463	351	340	394	672
CHFM306 - 6235	-(B) - Ratio	22	6	1253	351	340	394	627	1463	351	340	394	672
CHFM406 - 6235	-(B) - Ratio	30	6	1368	351	340	394	673	1583	351	340	394	761
CHFM506 - 6235	-(B) - Ratio	37	6	1368	351	340	394	673	1583	351	340	394	761
CHFM606 - 6235	-(B) - Ratio	45	6	1423	351	390	484	762	-	-	-	-	-
CHFM756 - 6235	-(B) - Ratio	55	6	1503	351	390	485	816	-	-	-	-	-

- Note: 1. \square indicates motor capacity.
 2. Dimension of shaft end diameter: Dimension tolerance conforms to JIS B 0401-1976 "h6."
 3. Dimension of shaft end key: Dimension tolerance conforms to JIS B 1301-1996 "Parallel Key."
 4. Pilot diameter (ϕD_3): Dimension tolerance conforms to JIS B 0401-1976 "g6."

Dimension Tables Gearmotors (Horizontal Direction, Flange Mount)

CHFM^{Note 1} - 6245 to 6265

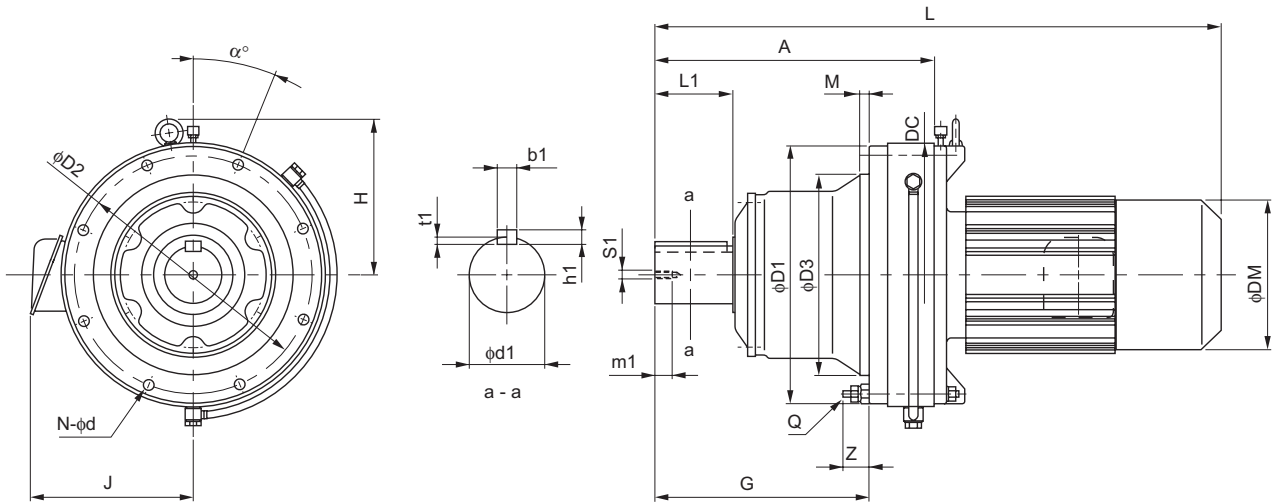

Dimension Tables
CHFM
GEARMOTORS

Frame size	A	G	D1	D2	D3	DC	Q	Z	M	N	d	α°	Output Shaft ^{Note 2, 3, 6}						
													d1	L1	b1	h1	t1	S1	m1
6245	657	529	615	560	500	614	M24	65	25	12	27	15	140	200	36	20	12	M24	41
6255	775	616	666	610	540	670	M24	86	30	12	27	15	160	240	40	22	13	M30	49
6265	892	712	730	660	570	736	M30	82	40	12	34	15	170	300	40	22	13	M30	49

Model	Note 5	Motor		Standard					With Brake				
		kW	P	L	H	J	DM	W(kg)	L	H	J	DM	W(kg)
CHFM206 - 6245	- (B) - Ratio	15	6	1282	359	340	394	747	1447	359	340	394	780
CHFM256 - 6245	- (B) - Ratio	18.5	6	1282	359	340	394	747	1447	359	340	394	794
CHFM306 - 6245	- (B) - Ratio	22	6	1282	359	340	394	747	1447	359	340	394	794
CHFM406 - 6245	- (B) - Ratio	30	6	1397	359	340	394	793	1612	359	340	394	881
CHFM506 - 6245	- (B) - Ratio	37	6	1397	359	340	394	793	1612	359	340	394	881
CHFM606 - 6245	- (B) - Ratio	45	6	1452	359	390	484	884	-	359	-	-	-
CHFM756 - 6245	- (B) - Ratio	55	6	1532	359	390	485	933	-	359	-	-	-
CHFM256 - 6255	- (B) - Ratio	18.5	6	1400	386	340	394	992	1565	386	340	394	1039
CHFM306 - 6255	- (B) - Ratio	22	6	1400	386	340	394	992	1565	386	340	394	1039
CHFM406 - 6255	- (B) - Ratio	30	6	1515	386	340	394	1037	1730	386	340	394	1125
CHFM506 - 6255	- (B) - Ratio	37	6	1515	386	340	394	1037	1730	386	340	394	1125
CHFM606 - 6255	- (B) - Ratio	45	6	1570	386	390	484	1117	-	-	-	-	-
CHFM756 - 6255	- (B) - Ratio	55	6	1650	386	390	485	1172	-	-	-	-	-
CHFM306 - 6265	- (B) - Ratio	22	6	1517	453	340	394	1230	1727	453	340	394	1277
CHFM406 - 6265	- (B) - Ratio	30	6	1632	453	340	394	1275	1847	453	340	394	1363
CHFM506 - 6265	- (B) - Ratio	37	6	1632	453	340	394	1275	1847	453	340	394	1363
CHFM606 - 6265	- (B) - Ratio	45	6	1687	453	390	484	1370	-	-	-	-	-

Note: 5. "B" after the frame size indicates models equipped with brake.
 6. Dimension of shaft end: Refer to pages F-28 to F-29 for details.
 7. Dimensions in above drawings are subject to change without notice.

Dimension Tables Gearmotors (Universal Direction, Flange Mount)

CNFM^{Note 1} - 606□DA to 612□DB

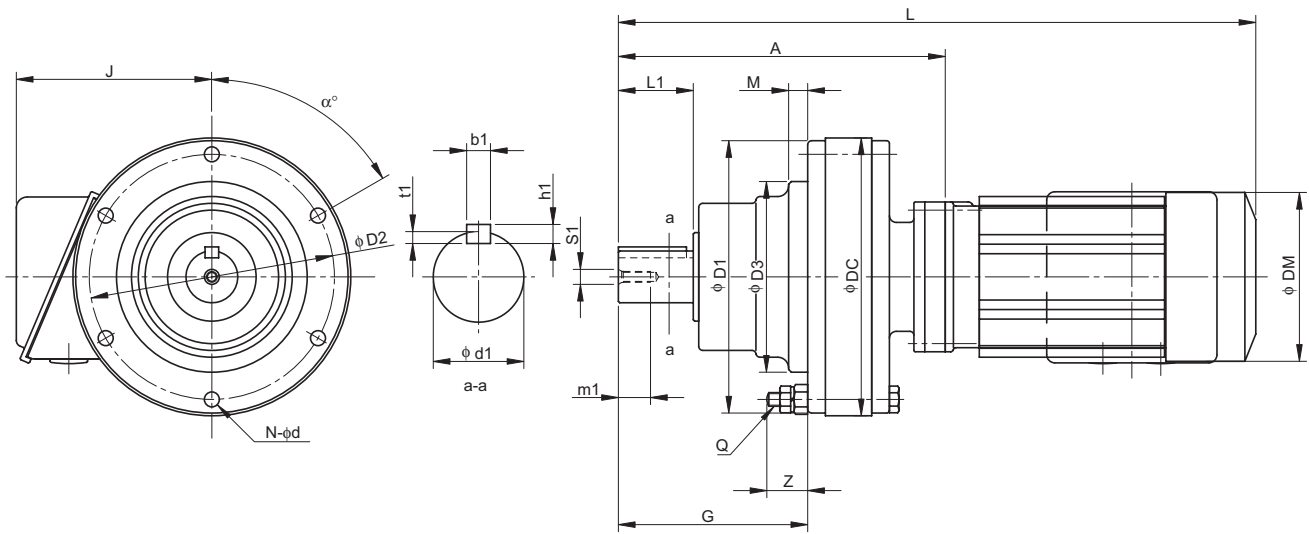

Frame size <small>Note 5</small>	A	G	D1	D2	D3	DC	Q	Z	M	N	d	α°	Output Shaft <small>Note 2, 3, 7</small>						
													d1	L1	b1	h1	t1	S1	m1
606□DA	125	68	110	98	80	110	M6	23	4	6	6.6	60	14	25	5	5	3	M5	16
607□DA	131	74	110	98	80	110	M6	23	4	6	6.6	60	18	30	6	6	3.5	M6	16
609□DA	190	114	150	134	105	150	M8	28	6	8	9	22.5	28	35	8	7	4	M8	20
610□DA	204	114	150	134	105	150	M8	28	6	8	9	22.5	28	35	8	7	4	M8	20
612□DA	240	139	200	180	140	204	M10	33	14	6	11	60	38	55	10	8	5	M8	20
612□DB	252	139	200	180	140	204	M10	33	14	6	11	60	38	55	10	8	5	M8	20

Model <small>Note 5, 6</small>	Motor		Standard					With Brake			
	kW	P	L	J	DM	W(kg)	L	J	DM	W(kg)	
CNFM01 - 606□DA - (B) - Ratio	0.1	4	287	130	119	8	294	130	124	9.5	
CNFM01 - 607□DA - (B) - Ratio	0.1	4	293	130	119	9	300	130	124	10.5	
CNFM02 - 607□DA - (B) - Ratio	0.2	4	311	130	124	10	339	130	124	12	
CNFM01 - 609□DA - (B) - Ratio	0.1	4	352	130	119	14	359	130	124	15	
CNFM02 - 609□DA - (B) - Ratio	0.2	4	370	130	124	15	398	130	124	16	
CNFM03 - 609□DA - (B) - Ratio	0.25	4	370	130	124	15	398	130	124	16	
CNFM05 - 609□DA - (B) - Ratio	0.4	4	386	130	124	16	418	130	124	17	
CNFM01 - 610□DA - (B) - Ratio	0.1	4	366	130	119	15	373	130	124	16	
CNFM02 - 610□DA - (B) - Ratio	0.2	4	384	130	124	16	412	130	124	17	
CNFM03 - 610□DA - (B) - Ratio	0.25	4	384	130	124	16	412	130	124	17	
CNFM05 - 610□DA - (B) - Ratio	0.4	4	400	130	124	17	432	130	124	18	
CNFM01 - 612□DA - (B) - Ratio	0.1	4	402	130	119	26	409	130	124	27	
CNFM02 - 612□DA - (B) - Ratio	0.2	4	420	130	124	27	448	130	124	28	
CNFM03 - 612□DA - (B) - Ratio	0.25	4	420	130	124	27	448	130	124	28	
CNFM05 - 612□DA - (B) - Ratio	0.4	4	436	130	124	28	468	130	124	29	
CNFM01 - 612□DB - (B) - Ratio	0.1	4	414	130	119	29	421	130	124	31	
CNFM02 - 612□DB - (B) - Ratio	0.2	4	432	130	124	30	473	130	124	32	
CNFM03 - 612□DB - (B) - Ratio	0.25	4	432	130	124	30	473	130	124	32	
CNFM05 - 612□DB - (B) - Ratio	0.4	4	448	130	124	31	473	130	124	33	
CNFM08 - 612□DB - (B) - Ratio	0.55	4	489	140	148	35	532	140	148	38	
CNFM1 - 612□DB - (B) - Ratio	0.75	4	489	140	148	35	532	140	148	38	
CNFM1H - 612□DB - (B) - Ratio	1.1	4	516	145	160	39	578	145	160	44	
CNFM2 - 612□DB - (B) - Ratio	1.5	4	516	145	160	39	578	145	160	44	

- Note: 1. □ indicates motor capacity.
 2. Dimension of shaft end diameter: Dimension tolerance conforms to JIS B 0401-1976 "h6."
 3. Dimension of shaft end key: Dimension tolerance conforms to JIS B 1301-1996 "Parallel Key."
 4. Pilot diameter ($\phi D3$): Dimension tolerance conforms to JIS B 0401-1976 "g6."

Dimension Tables Gearmotors (Horizontal Direction, Flange Mount)

CHFM^{Note 1} - 613□DA to 614□DC

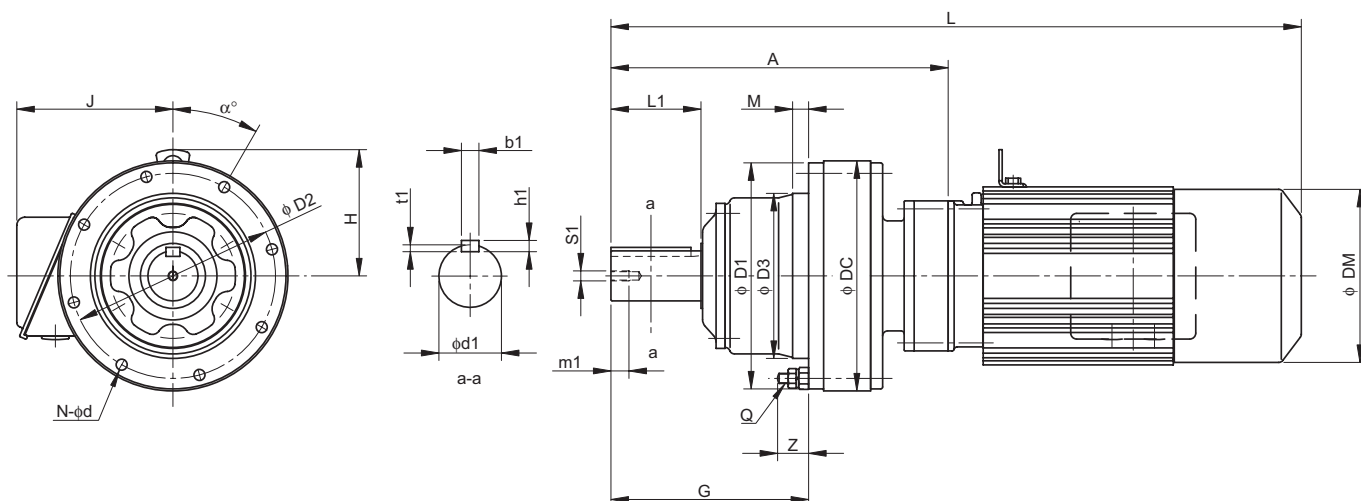

GEARMOTORS
Dimension Tables
CHFM

Frame size <small>Note 5</small>	A	G	D1	D2	D3	DC	H	Q	Z	M	N	d	α°	Output Shaft <small>Note 2, 3, 7</small>						
														d1	L1	b1	h1	t1	S1	m1
613□DA	294	178	226	205	165	230	150	M10	31	16	6	11	60	50	70	14	9	5.5	M10	18
613□DB	303	178	226	205	165	230	150	M10	31	16	6	11	60	50	70	14	9	5.5	M10	18
613□DC	317	178	226	205	165	230	150	M10	31	16	6	11	60	50	70	14	9	5.5	M10	18
614□DA	314	198	226	205	165	230	150	M10	31	16	6	11	60	50	90	14	9	5.5	M10	18
614□DB	323	198	226	205	165	230	150	M10	31	16	6	11	60	50	90	14	9	5.5	M10	18
614□DC	337	198	226	205	165	230	150	M10	31	16	6	11	60	50	90	14	9	5.5	M10	18

Model <small>Note 5, 6</small>	Motor		Standard				With Brake			
	kW	P	L	J	DM	W(kg)	L	J	DM	W(kg)
CHFM02 - 613□DA - (B) - Ratio	0.2	4	474	130	124	40	502	130	124	41
CHFM03 - 613□DA - (B) - Ratio	0.25	4	474	130	124	40	522	130	124	41
CHFM05 - 613□DA - (B) - Ratio	0.4	4	490	130	124	41	522	130	124	42
CHFM02 - 613□DB - (B) - Ratio	0.2	4	483	130	124	42	511	130	124	44
CHFM03 - 613□DB - (B) - Ratio	0.25	4	483	130	124	42	511	130	124	44
CHFM05 - 613□DB - (B) - Ratio	0.4	4	499	130	124	43	531	130	124	45
CHFM08 - 613□DB - (B) - Ratio	0.55	4	540	140	148	47	583	140	148	50
CHFM1 - 613□DB - (B) - Ratio	0.75	4	540	140	148	47	583	140	148	50
CHFM1H - 613□DB - (B) - Ratio	1.1	4	573	145	160	51	635	145	160	56
CHFM2 - 613□DB - (B) - Ratio	1.5	4	573	145	160	51	635	145	160	56
CHFM08 - 613□DC - (B) - Ratio	0.55	4	554	140	148	49	597	140	148	52
CHFM1 - 613□DC - (B) - Ratio	0.75	4	554	140	148	49	597	140	148	52
CHFM2 - 613□DC - (B) - Ratio	1.5	4	587	145	160	53	649	145	160	58
CHFM3 - 613□DC - (B) - Ratio	2.2	4	607	152	173	57	670	152	173	63
CHFM02 - 614□DA - (B) - Ratio	0.2	4	494	130	124	40	522	130	124	41
CHFM03 - 614□DA - (B) - Ratio	0.25	4	494	130	124	40	522	130	124	41
CHFM05 - 614□DA - (B) - Ratio	0.4	4	510	130	124	41	542	130	124	42
CHFM02 - 614□DB - (B) - Ratio	0.2	4	503	130	124	42	531	130	124	44
CHFM03 - 614□DB - (B) - Ratio	0.25	4	503	130	124	42	531	130	124	44
CHFM05 - 614□DB - (B) - Ratio	0.4	4	519	130	124	43	551	130	124	47
CHFM08 - 614□DB - (B) - Ratio	0.55	4	560	140	148	47	603	140	148	50
CHFM1 - 614□DB - (B) - Ratio	0.75	4	560	140	148	47	603	140	148	50
CHFM1H - 614□DB - (B) - Ratio	1.1	4	593	145	160	51	655	145	160	54
CHFM2 - 614□DB - (B) - Ratio	1.5	4	593	145	160	51	655	145	160	54
CHFM08 - 614□DC - (B) - Ratio	0.55	4	574	140	148	49	617	140	148	52
CHFM1 - 614□DC - (B) - Ratio	0.75	4	574	140	148	49	617	140	148	52
CHFM1H - 614□DC - (B) - Ratio	1.1	4	607	145	160	53	669	145	160	58
CHFM2 - 614□DC - (B) - Ratio	1.5	4	607	145	160	53	669	145	160	58
CHFM3 - 614□DC - (B) - Ratio	2.2	4	627	152	173	57	690	152	173	63

Note: 5. □ indicates 0 or 5, expressing combination with reduction ratio. Refer to the Selection Table for details.
 6. "B" after the frame size indicates models equipped with brake.
 7. Dimension of shaft end: Refer to pages F-28 to F-29 for details.
 8. Dimensions in above drawings are subject to change without notice.

Dimension Tables Gearmotors (Horizontal Direction, Flange Mount)

CHFM^{Note 1} - 616□DA to 618□DA

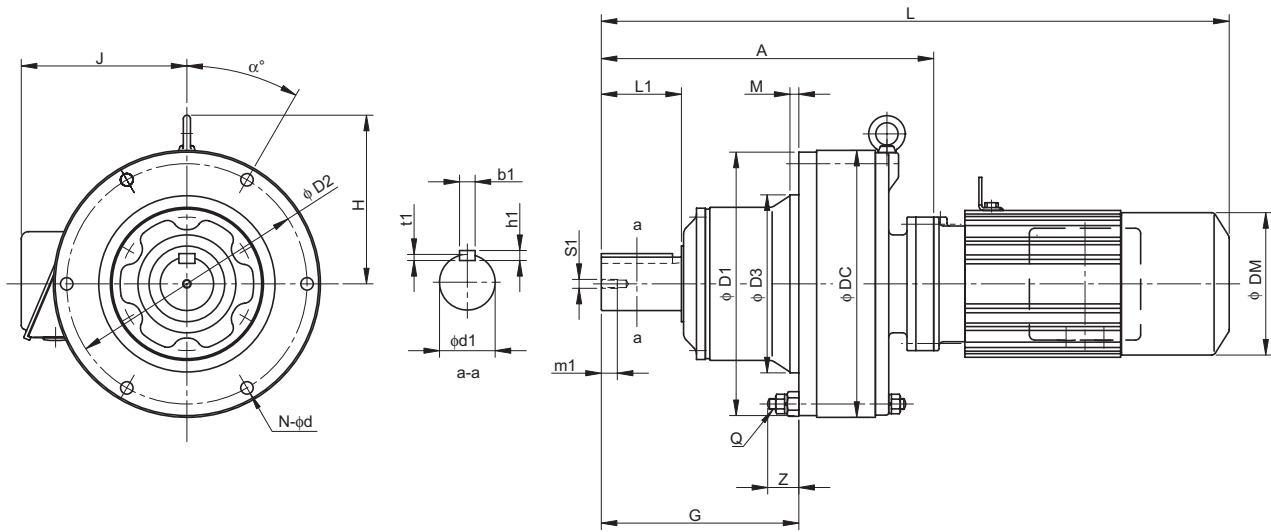

Frame size <small>Note 5</small>	A	G	D1	D2	D3	DC	H	Q	Z	M	N	d	α°	Output Shaft <small>Note 2, 3, 7</small>						
														d1	L1	b1	h1	t1	S1	m1
616□DA	373	222	296	270	200	300	189	M12	35	10	6	14	30	60	90	18	11	7	M10	18
616□DB	387	222	296	270	200	300	189	M12	35	10	6	14	30	60	90	18	11	7	M10	18
617□DA	418	262	330	300	250	340	216	M12	41	12	8	14	22.5	70	90	20	12	7.5	M12	24
617□DB	432	262	330	300	250	340	216	M12	41	12	8	14	22.5	70	90	20	12	7.5	M12	24
618□DA	474	299	360	330	280	370	231	M12	38	12	8	14	22.5	80	110	22	14	9	M12	24

Model <small>Note 5, 6</small>	Motor		Standard				With Brake			
	kW	P	L	J	DM	W(kg)	L	J	DM	W(kg)
CHFM02 -616□DA - (B) - Ratio	0.2	4	553	130	124	72	581	130	124	74
CHFM03 -616□DA - (B) - Ratio	0.25	4	553	130	124	72	581	130	124	74
CHFM05 -616□DA - (B) - Ratio	0.4	4	569	130	124	73	601	130	124	75
CHFM08 -616□DA - (B) - Ratio	0.55	4	610	140	148	77	653	140	148	80
CHFM1 -616□DA - (B) - Ratio	0.75	4	610	140	148	77	653	140	148	80
CHFM1H -616□DA - (B) - Ratio	1.1	4	643	145	160	81	705	145	160	86
CHFM2 -616□DA - (B) - Ratio	1.5	4	643	145	160	81	705	145	160	86
CHFM08 -616□DB - (B) - Ratio	0.55	4	624	140	148	79	667	140	148	82
CHFM1 -616□DB - (B) - Ratio	0.75	4	624	140	148	79	667	140	148	82
CHFM1H -616□DB - (B) - Ratio	1.1	4	657	145	160	83	719	145	160	88
CHFM2 -616□DB - (B) - Ratio	1.5	4	657	145	160	83	719	145	160	88
CHFM3 -616□DB - (B) - Ratio	2.2	4	677	152	173	87	740	152	173	93
CHFM02 -617□DA - (B) - Ratio	0.2	4	598	130	124	92	626	130	124	94
CHFM03 -617□DA - (B) - Ratio	0.25	4	598	130	124	92	626	130	124	94
CHFM05 -617□DA - (B) - Ratio	0.4	4	614	130	124	93	646	130	124	95
CHFM08 -617□DA - (B) - Ratio	0.55	4	655	140	148	97	698	140	148	100
CHFM1 -617□DA - (B) - Ratio	0.75	4	655	140	148	97	698	140	148	100
CHFM1H -617□DA - (B) - Ratio	1.1	4	688	145	160	101	750	145	160	106
CHFM2 -617□DA - (B) - Ratio	1.5	4	688	145	160	101	750	145	160	106
CHFM08 -617□DB - (B) - Ratio	0.55	4	669	140	148	98	712	140	148	101
CHFM1 -617□DB - (B) - Ratio	0.75	4	669	140	148	98	712	140	148	101
CHFM1H -617□DB - (B) - Ratio	1.1	4	702	145	160	102	764	145	160	107
CHFM2 -617□DB - (B) - Ratio	1.5	4	702	145	160	102	764	145	160	107
CHFM3 -617□DB - (B) - Ratio	2.2	4	722	152	173	106	785	152	173	112
CHFM05 -618□DA - (B) - Ratio	0.4	4	670	130	124	136	702	130	124	138
CHFM08 -618□DA - (B) - Ratio	0.55	4	711	140	148	140	754	140	148	143
CHFM1 -618□DA - (B) - Ratio	0.75	4	711	140	148	140	754	140	148	143
CHFM1H -618□DA - (B) - Ratio	1.1	4	744	145	160	144	806	145	160	149
CHFM2 -618□DA - (B) - Ratio	1.5	4	744	145	160	144	806	145	160	149
CHFM3 -618□DA - (B) - Ratio	2.2	4	764	152	173	148	827	152	173	154

- Note: 1. □ indicates motor capacity.
 2. Dimension of shaft end diameter: Dimension tolerance conforms to JIS B 0401-1976 "h6."
 3. Dimension of shaft end key: Dimension tolerance conforms to JIS B 1301-1996 "Parallel Key."
 4. Pilot diameter ($\phi D3$): Dimension tolerance conforms to JIS B 0401-1976 "g6."

Dimension Tables Gearmotors (Horizontal Direction, Flange Mount)

CHFM^{Note 1} - 616□DC to 618□DB

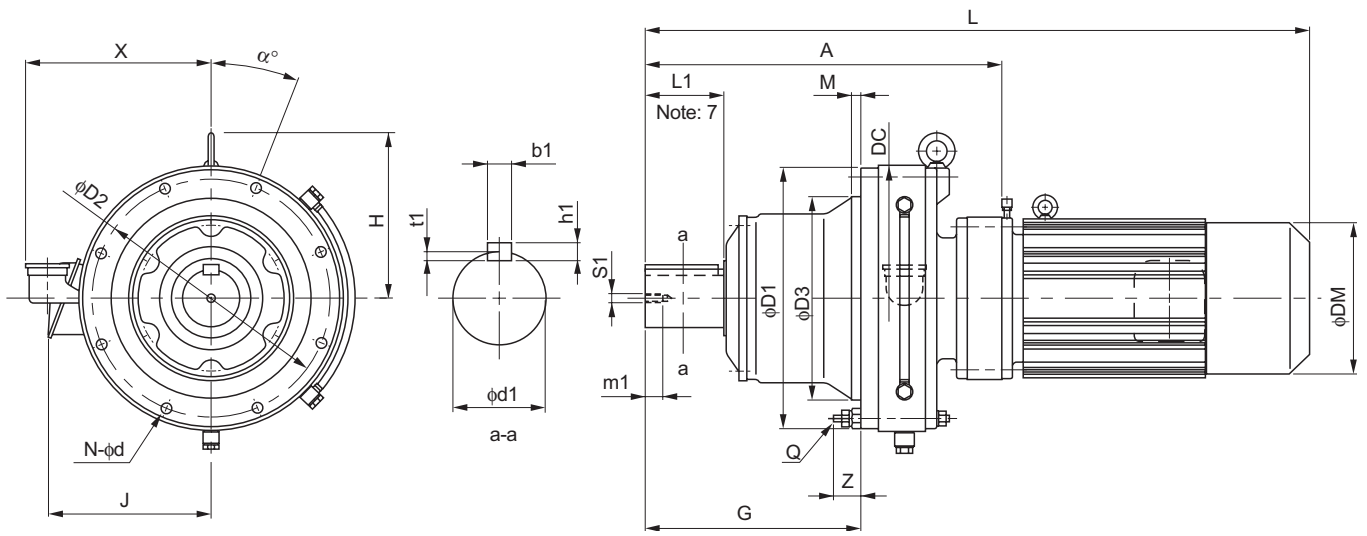

Dimension Tables
CHFM
GEARMOTORS

Frame size <small>Note 5</small>	A	G	D1	D2	D3	DC	H	Q	Z	M	N	d	α°	X	Output Shaft <small>Note 2, 3, 7</small>						
															d1	L1	b1	h1	t1	S1	m1
616□DC	389	222	296	270	200	300	189	M12	35	10	6	14	30	228	60	90	18	11	7	M10	18
617□DC	436	262	330	300	250	340	216	M12	41	12	8	14	22.5	243	70	90	20	12	7.5	M12	24
618□DB	496	299	360	330	280	370	231	M12	38	12	8	14	22.5	258	80	110	22	14	9	M12	24

Model <small>Note 5, 6</small>	Motor		Standard				With Brake			
	kW	P	L	J	DM	W(kg)	L	J	DM	W(kg)
CHFM1H -616□DC - (B) - Ratio	1.1	4	659	145	160	89	721	145	160	94
CHFM2 -616□DC - (B) - Ratio	1.5	4	659	145	160	89	721	145	160	94
CHFM3 -616□DC - (B) - Ratio	2.2	4	679	152	173	93	742	152	173	100
CHFM4 -616□DC - (B) - Ratio	3.0	4	702	168	212	103	774	168	212	113
CHFM5 -616□DC - (B) - Ratio	3.7	4	702	168	212	103	774	168	212	113
CHFM8 -616□DC - (B) - Ratio	5.5	4	746	168	212	110	818	168	212	120
CHFM1H -617□DC - (B) - Ratio	1.1	4	706	145	160	113	768	145	160	118
CHFM2 -617□DC - (B) - Ratio	1.5	4	706	145	160	113	768	145	160	118
CHFM3 -617□DC - (B) - Ratio	2.2	4	726	152	173	117	789	152	173	124
CHFM4 -617□DC - (B) - Ratio	3.0	4	749	168	212	127	821	168	212	137
CHFM5 -617□DC - (B) - Ratio	3.7	4	749	168	212	127	821	168	212	137
CHFM8 -617□DC - (B) - Ratio	5.5	4	793	168	212	134	865	168	212	144
CHFM1H -618□DB - (B) - Ratio	1.1	4	766	145	160	159	828	145	160	164
CHFM2 -618□DB - (B) - Ratio	1.5	4	766	145	160	159	828	145	160	164
CHFM3 -618□DB - (B) - Ratio	2.2	4	786	152	173	162	849	152	173	169
CHFM4 -618□DB - (B) - Ratio	3.0	4	809	168	212	172	881	168	212	182
CHFM5 -618□DB - (B) - Ratio	3.7	4	809	168	212	172	881	168	212	182
CHFM8 -618□DB - (B) - Ratio	5.5	4	853	168	212	179	925	168	212	189
CHFM10 -618□DB - (B) - Ratio	7.5	4	876	213	251	194	971	213	251	212
CHFM15 -618□DB - (B) - Ratio	11	4	936	213	251	208	1031	213	251	226

Note: 5. □ indicates 0 or 5, expressing combination with reduction ratio. Refer to the Selection Table for details.
 6. "B" after the frame size indicates models equipped with brake.
 7. Dimension of shaft end: Refer to pages F-28 to F-29 for details.
 8. Dimensions in above drawings are subject to change without notice.

Dimension Tables Gearmotors (Horizontal Direction, Flange Mount)

CHFM^{Note 1} - 619□DA to 619□DB

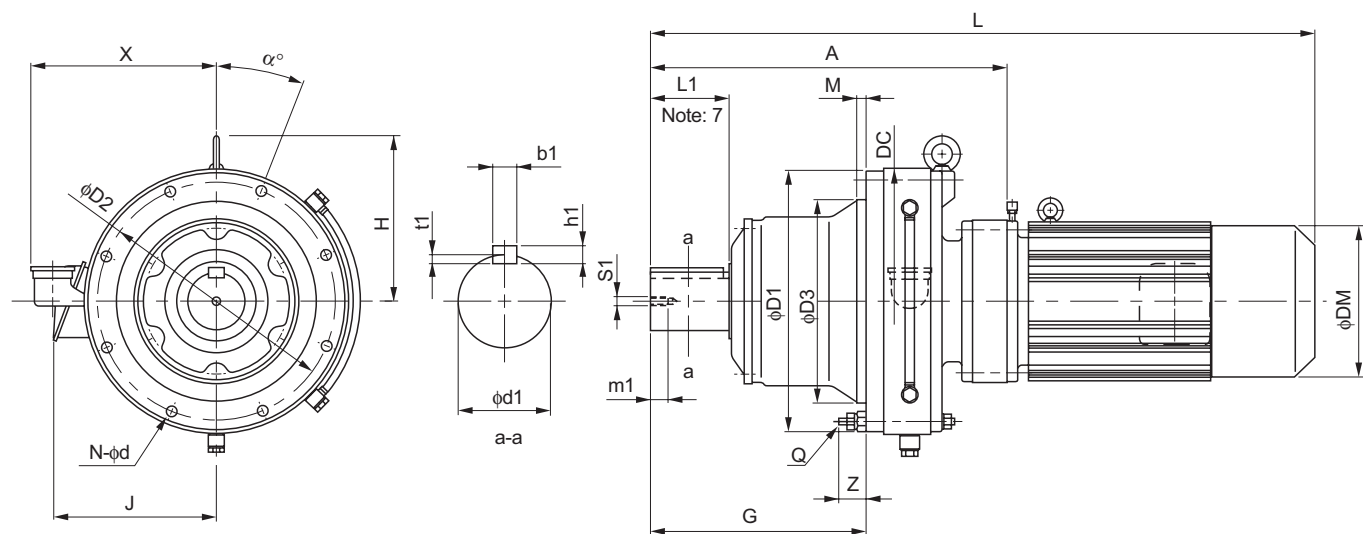

Frame size <small>Note 5</small>	A	G	D1	D2	D3	DC	H	Q	Z	M	N	d	α°	X	Output Shaft <small>Note 2, 3, 7</small>						
															d1	L1	b1	h1	t1	S1	m1
619□DA	556	365	420	380	320	430	281	M12	43	10	12	14	15	285	95	135	25	14	9	M20	34
619□DB	572	365	420	380	320	430	281	M12	43	10	12	14	15	285	95	135	25	14	9	M20	34

Model <small>Note 5, 6</small>	Motor		Standard					With Brake			
	kW	P	L	J	DM	W(kg)	L	J	DM	W(kg)	
CHFM1 - 619□DA - (B) - Ratio	0.75	4	793	140	148	201	836	140	148	204	
CHFM1H - 619□DA - (B) - Ratio	1.1	4	826	145	160	205	888	145	160	210	
CHFM2 - 619□DA - (B) - Ratio	1.5	4	826	145	160	205	888	145	160	210	
CHFM3 - 619□DA - (B) - Ratio	2.2	4	846	152	173	209	909	152	173	216	
CHFM4 - 619□DA - (B) - Ratio	3.0	4	869	168	212	219	941	168	212	229	
CHFM5 - 619□DA - (B) - Ratio	3.7	4	869	168	212	219	941	168	212	229	
CHFM8 - 619□DA - (B) - Ratio	5.5	4	913	168	212	226	985	168	212	236	
CHFM2 - 619□DB - (B) - Ratio	1.5	4	842	145	160	212	904	145	160	217	
CHFM3 - 619□DB - (B) - Ratio	2.2	4	862	152	173	216	925	152	173	223	
CHFM4 - 619□DB - (B) - Ratio	3.0	4	885	168	212	226	957	168	212	236	
CHFM5 - 619□DB - (B) - Ratio	3.7	4	885	168	212	226	957	168	212	236	
CHFM8 - 619□DB - (B) - Ratio	5.5	4	929	168	212	233	1001	168	212	243	
CHFM10 - 619□DB - (B) - Ratio	7.5	4	952	213	251	248	1047	213	251	266	
CHFM15 - 619□DB - (B) - Ratio	11	4	1012	213	251	262	1107	213	251	280	
CHFM20 - 619□DB - (B) - Ratio	15	4	1102	261	324	314	1207	261	324	348	

- Note: 1. □ indicates motor capacity.
 2. Dimension of shaft end diameter: Dimension tolerance conforms to JIS B 0401-1976 "h6."
 3. Dimension of shaft end key: Dimension tolerance conforms to JIS B 1301-1996 "Parallel Key."
 4. Pilot diameter (φD3): Dimension tolerance conforms to JIS B 0401-1976 "g6."

Dimension Tables Gearmotors (Horizontal Direction, Flange Mount)

CHFM^{Note 1} - 6205DA to 6215DA

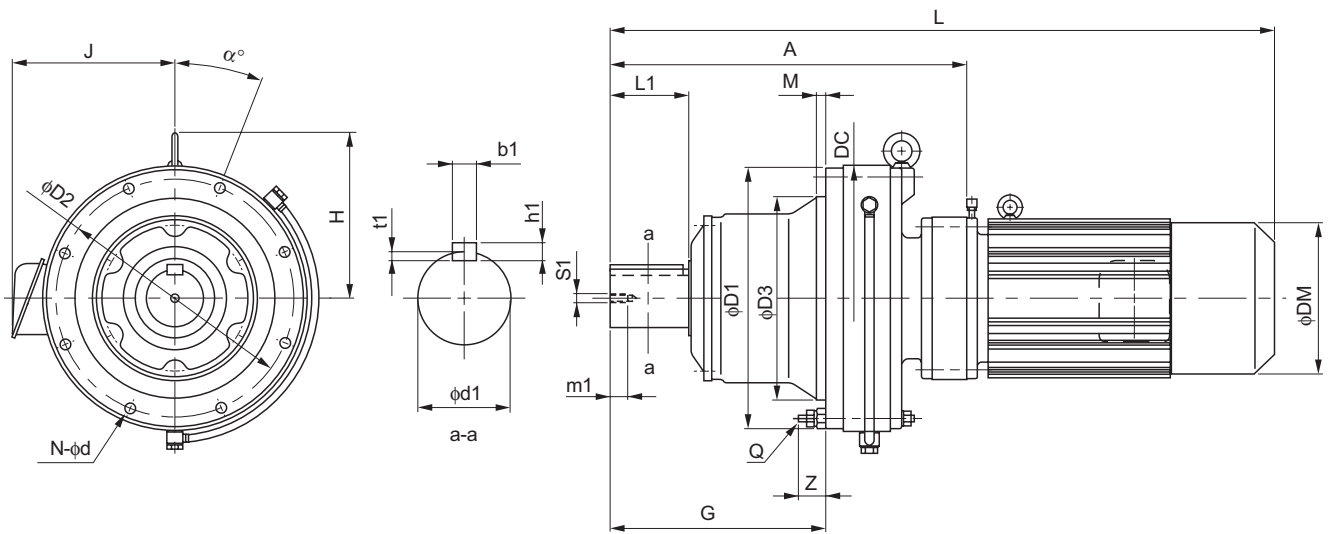

Dimension Tables
CHFM
GEARMOTORS

Frame size	A	G	D1	D2	D3	DC	H	Q	Z	M	N	d	α°	Output Shaft ^{Note 2, 3, 7}						
														d1	L1	b1	h1	t1	S1	m1
6205DA	597	410	443	405	360	448	283	M16	57	20	12	18	15	100	165	28	16	10	M20	34
6205DB	624	410	443	405	360	448	283	M16	57	20	12	18	15	100	165	28	16	10	M20	34
6215DA	650	423	480	440	390	485	312	M18	57	20	12	20.5	15	110	165	28	16	10	M20	34

Model	Note 6	Motor		Standard				With Brake			
		kW	P	L	J	DM	W(kg)	L	J	DM	W(kg)
CHFM1	-6205DA - (B) - Ratio	0.75	4	834	140	148	225	877	140	148	228
CHFM2	-6205DA - (B) - Ratio	1.5	4	867	145	160	229	929	145	160	234
CHFM3	-6205DA - (B) - Ratio	2.2	4	887	152	173	233	949	152	173	240
CHFM4	-6205DA - (B) - Ratio	3.0	4	910	168	212	243	982	168	212	253
CHFM5	-6205DA - (B) - Ratio	3.7	4	910	168	212	243	982	168	212	253
CHFM8	-6205DA - (B) - Ratio	5.5	4	954	168	212	250	1026	168	212	260
CHFM3	-6205DB - (B) - Ratio	2.2	4	914	152	173	245	977	152	173	252
CHFM4	-6205DB - (B) - Ratio	3.0	4	937	168	212	255	1009	168	212	265
CHFM5	-6205DB - (B) - Ratio	3.7	4	937	168	212	255	1009	168	212	265
CHFM8	-6205DB - (B) - Ratio	5.5	4	981	168	212	262	1053	168	212	272
CHFM10	-6205DB - (B) - Ratio	7.5	4	1004	213	251	277	1099	213	251	295
CHFM15	-6205DB - (B) - Ratio	11	4	1064	213	251	290	1159	213	251	308
CHFM20	-6205DB - (B) - Ratio	15	4	1154	261	324	342	1249	261	324	375
CHFM2	-6215DA - (B) - Ratio	1.5	4	920	145	160	321	982	145	160	326
CHFM3	-6215DA - (B) - Ratio	2.2	4	940	152	173	324	1003	152	173	331
CHFM4	-6215DA - (B) - Ratio	3.0	4	963	168	212	334	1035	168	212	344
CHFM5	-6215DA - (B) - Ratio	3.7	4	963	168	212	334	1035	168	212	344
CHFM8	-6215DA - (B) - Ratio	5.5	4	1007	168	212	341	1079	168	212	351
CHFM10	-6215DA - (B) - Ratio	7.5	4	1030	213	251	356	1125	213	251	374
CHFM15	-6215DA - (B) - Ratio	11	4	1090	213	251	369	1185	213	251	387
CHFM20	-6215DA - (B) - Ratio	15	4	1180	261	324	421	1285	261	324	455

Note: 5. □ indicates 0 or 5, expressing combination with reduction ratio. Refer to the Selection Table for details.
 6. "B" after the frame size indicates models equipped with brake.
 7. Dimension of shaft end: Refer to pages F-28 to F-29 for details.
 8. Dimensions in above drawings are subject to change without notice.

Dimension Tables Gearmotors (Horizontal Direction, Flange Mount)

CHFM^{Note 1} - 6215DB to 6225DB

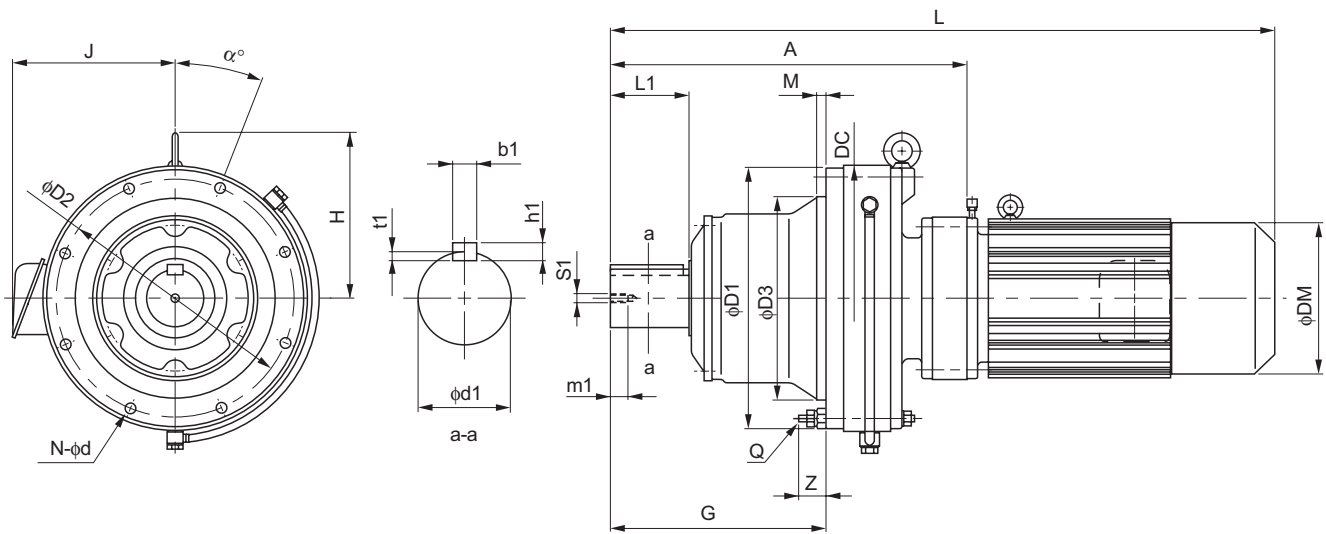

Frame size	A	G	D1	D2	D3	DC	H	Q	Z	M	N	d	α°	Output Shaft <small>Note 2, 3, 6</small>						
														d1	L1	b1	h1	t1	S1	m1
6215DB	675	423	480	440	390	485	312	M18	57	20	12	20.5	15	110	165	28	16	10	M20	34
6225DA	692	454	521	475	420	526	333	M20	65	20	12	22	15	120	165	32	18	11	M20	34
6225DB	735	454	521	475	420	526	333	M20	65	20	12	22	15	120	165	32	18	11	M20	34

Model	Note 5	Motor		Standard				With Brake			
		kW	P	L	J	DM	W(kg)	L	J	DM	W(kg)
CHFM5	- 6215DB - (B) - Ratio	3.7	4	993	168	212	353	1065	168	212	363
CHFM8	- 6215DB - (B) - Ratio	5.5	4	1037	168	212	360	1109	168	212	370
CHFM10	- 6215DB - (B) - Ratio	7.5	4	1060	213	251	376	1155	213	251	393
CHFM15	- 6215DB - (B) - Ratio	11	4	1120	213	251	390	1215	213	251	407
CHFM20	- 6215DB - (B) - Ratio	15	4	1205	261	324	443	1310	261	324	477
CHFM25	- 6215DB - (B) - Ratio	18.5	4	1300	340	394	518	1465	340	394	569
CHFM30	- 6215DB - (B) - Ratio	22	4	1300	340	394	518	1465	340	394	569
CHFM2	- 6225DA - (B) - Ratio	1.5	4	962	145	160	378	1024	145	160	383
CHFM3	- 6225DA - (B) - Ratio	2.2	4	982	152	173	381	1045	152	173	388
CHFM4	- 6225DA - (B) - Ratio	3.0	4	1005	168	212	391	1077	168	212	401
CHFM5	- 6225DA - (B) - Ratio	3.7	4	1005	168	212	391	1077	168	212	401
CHFM8	- 6225DA - (B) - Ratio	5.5	4	1049	168	212	398	1121	168	212	408
CHFM10	- 6225DA - (B) - Ratio	7.5	4	1072	213	251	413	1167	213	251	431
CHFM15	- 6225DA - (B) - Ratio	11	4	1132	213	251	427	1227	213	251	445
CHFM20	- 6225DA - (B) - Ratio	15	4	1222	261	324	479	1312	261	324	512
CHFM5	- 6225DB - (B) - Ratio	3.7	4	1058	168	212	436	1130	168	212	447
CHFM8	- 6225DB - (B) - Ratio	5.5	4	1102	168	212	443	1174	168	212	454
CHFM10	- 6225DB - (B) - Ratio	7.5	4	1125	213	251	458	1220	213	251	476
CHFM15	- 6225DB - (B) - Ratio	11	4	1185	213	251	472	1280	213	251	490
CHFM20	- 6225DB - (B) - Ratio	15	4	1265	261	324	526	1370	261	324	560
CHFM25	- 6225DB - (B) - Ratio	18.5	4	1360	340	394	598	1525	340	394	649
CHFM30	- 6225DB - (B) - Ratio	22	4	1360	340	394	598	1525	340	394	649
CHFM40	- 6225DB - (B) - Ratio	30	4	1360	340	394	615	1525	340	394	666

- Note: 1. □ indicates motor capacity.
 2. Dimension of shaft end diameter: Dimension tolerance conforms to JIS B 0401-1976 "h6."
 3. Dimension of shaft end key: Dimension tolerance conforms to JIS B 1301-1996 "Parallel Key."
 4. Pilot diameter (φD3): Dimension tolerance conforms to JIS B 0401-1976 "g6."

Dimension Tables Gearmotors (Horizontal Direction, Flange Mount)

CHFM - 6235DA to 6245DB

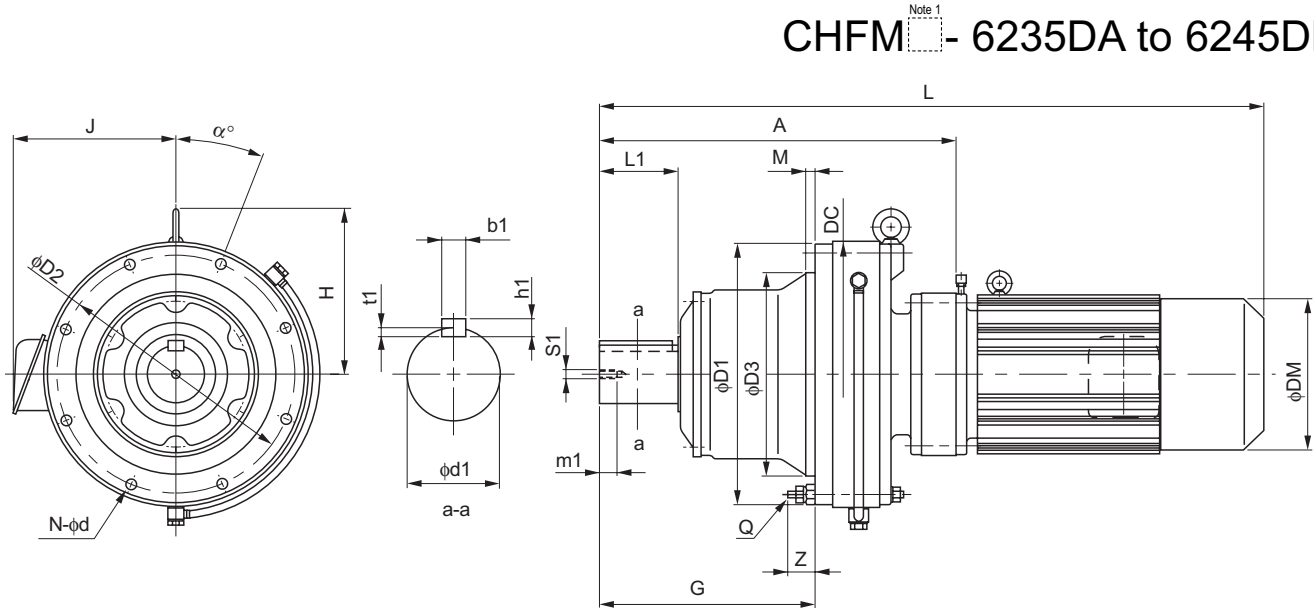

GEARMOTORS
Dimension Tables
CHFM

Frame size	A	G	D1	D2	D3	DC	H	Q	Z	M	N	d	α°	Output Shaft <small>Note 2, 3, 6</small>						
														d1	L1	b1	h1	t1	S1	m1
6235DA	778	505	557	510	455	562	351	M20	68	20	12	22	15	130	200	32	18	11	M24	41
6235DB	800	505	557	510	455	562	351	M20	68	20	12	22	15	130	200	32	18	11	M24	41
6245DA	816	529	615	560	500	614	395	M24	65	25	12	27	15	140	200	36	20	12	M24	41
6245DB	837	529	615	560	500	614	395	M24	65	25	12	27	15	140	200	36	20	12	M24	41

Model	Motor <small>Note 5</small>	Motor		Standard				With Brake			
		kW	P	L	J	DM	W(kg)	L	J	DM	W(kg)
CHFM3	-6235DA - (B) - Ratio	2.2	4	1068	152	173	485	1131	152	173	491
CHFM4	-6235DA - (B) - Ratio	3.0	4	1091	168	212	494	1163	168	212	504
CHFM5	-6235DA - (B) - Ratio	3.7	4	1091	168	212	494	1163	168	212	504
CHFM8	-6235DA - (B) - Ratio	5.5	4	1135	168	212	501	1207	168	212	511
CHFM10	-6235DA - (B) - Ratio	7.5	4	1163	213	251	517	1258	213	251	534
CHFM15	-6235DA - (B) - Ratio	11	4	1223	213	251	531	1318	213	251	548
CHFM20	-6235DA - (B) - Ratio	15	4	1308	261	324	584	1398	261	324	618
CHFM25	-6235DA - (B) - Ratio	18.5	4	1403	340	394	661	1568	340	394	712
CHFM30	-6235DA - (B) - Ratio	22	4	1403	340	394	661	1568	340	394	712
CHFM15	-6235DB - (B) - Ratio	11	4	1245	213	251	567	1340	213	251	585
CHFM20	-6235DB - (B) - Ratio	15	4	1330	261	324	629	1435	261	324	735
CHFM25	-6235DB - (B) - Ratio	18.5	4	1425	340	394	696	1590	340	394	747
CHFM30	-6235DB - (B) - Ratio	22	4	1425	340	394	696	1590	340	394	747
CHFM40	-6235DB - (B) - Ratio	30	4	1425	340	394	710	1590	340	394	753
CHFM50	-6235DB - (B) - Ratio	37	4	1540	340	394	748	1755	340	394	845
CHFM3	-6245DA - (B) - Ratio	2.2	4	1106	152	173	593	1169	152	173	599
CHFM4	-6245DA - (B) - Ratio	3.0	4	1129	168	212	602	1201	168	212	612
CHFM5	-6245DA - (B) - Ratio	3.7	4	1129	168	212	602	1201	168	212	612
CHFM8	-6245DA - (B) - Ratio	5.5	4	1173	168	212	609	1245	168	212	619
CHFM10	-6245DA - (B) - Ratio	7.5	4	1201	213	251	625	1296	213	251	642
CHFM15	-6245DA - (B) - Ratio	11	4	1261	213	251	639	1356	213	251	656
CHFM20	-6245DA - (B) - Ratio	15	4	1346	261	324	692	1451	261	324	726
CHFM25	-6245DA - (B) - Ratio	18.5	4	1441	340	394	763	1606	340	394	814
CHFM30	-6245DA - (B) - Ratio	22	4	1441	340	394	763	1606	340	394	814
CHFM15	-6245DB - (B) - Ratio	11	4	1282	213	251	663	1377	213	251	681
CHFM20	-6245DB - (B) - Ratio	15	4	1367	261	324	723	1472	261	324	752
CHFM25	-6245DB - (B) - Ratio	18.5	4	1462	340	394	789	1627	340	394	840
CHFM30	-6245DB - (B) - Ratio	22	4	1462	340	394	789	1627	340	394	840
CHFM40	-6245DB - (B) - Ratio	30	4	1462	340	394	806	1627	340	394	849
CHFM50	-6245DB - (B) - Ratio	37	4	1577	340	394	843	1792	340	394	940

Note: 5. "B" after the frame size indicates models equipped with brake.
 6. Dimension of shaft end: Refer to pages F-28 to F-29 for details.
 7. Dimensions in above drawings are subject to change without notice.

Dimension Tables Gearmotors (Horizontal Direction, Flange Mount)

CHFM^{Note 1} - 6255DA to 6265DA

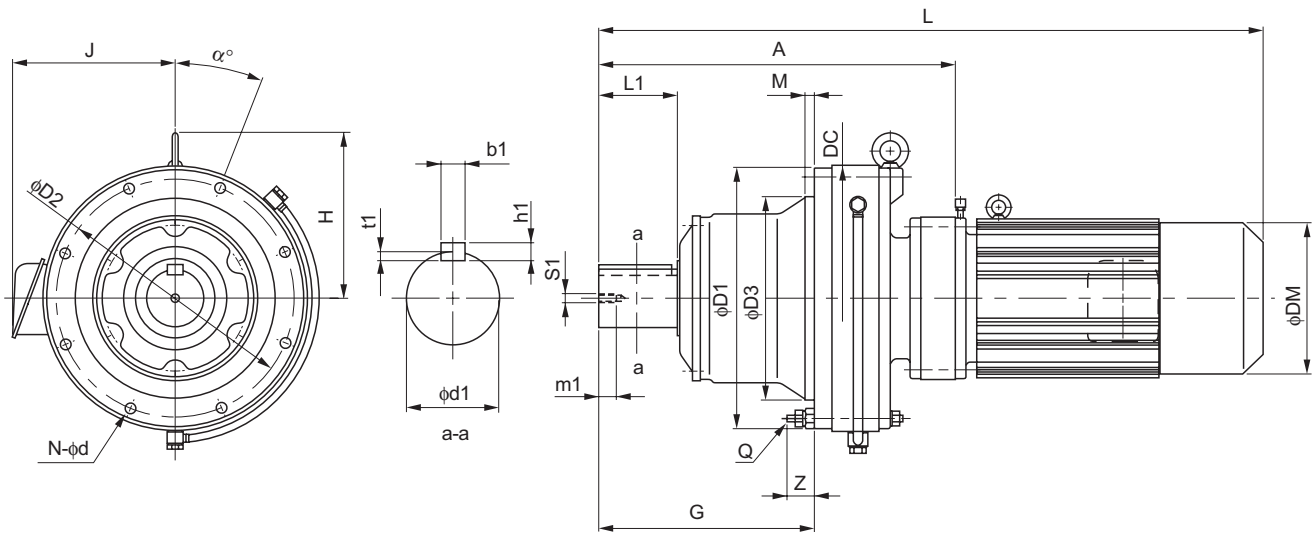

Frame size	A	G	D1	D2	D3	DC	H	Q	Z	M	N	d	α°	Output Shaft ^{Note 2, 3, 8}						
														d1	L1	b1	h1	t1	S1	m1
6255DA	956	616	666	610	540	670	386	M24	88	30	12	27	15	160	240	40	22	13	M30	49
6255DB	978	616	666	610	540	670	386	M24	88	30	12	27	15	160	240	40	22	13	M30	49
6265DA	1088	712	730	660	570	736	453	M30	82	40	12	34	15	170	300	40	22	13	M30	49

Model	Note 7	Motor		Standard				With Brake			
		kW	P	L	J	DM	W(kg)	L	J	DM	W(kg)
CHFM5	- 6255DA - (B) - Ratio	3.7	4	1284	168	212	868	1356	168	212	878
CHFM8	- 6255DA - (B) - Ratio	5.5	4	1328	168	212	878	1400	168	212	888
CHFM10	- 6255DA - (B) - Ratio	7.5	4	1346	213	251	893	1441	213	251	908
CHFM15	- 6255DA - (B) - Ratio	11	4	1406	213	251	908	1501	213	251	923
CHFM20	- 6255DA - (B) - Ratio	15	4	1486	261	324	958	1591	261	324	994
CHFM25	- 6255DA - (B) - Ratio	18.5	4	1581	340	394	1032	1746	340	394	1083
CHFM30	- 6255DA - (B) - Ratio	22	4	1581	340	394	1032	1746	340	394	1083
CHFM40	- 6255DA - (B) - Ratio	30	4	1581	340	394	1052	1746	340	394	1095
CHFM15	- 6255DB - (B) - Ratio	11	4	1443	213	251	981	1538	213	251	996
CHFM20	- 6255DB - (B) - Ratio	15	4	1508	261	324	1031	1613	261	324	1065
CHFM25	- 6255DB - (B) - Ratio	18.5	4	1603	340	394	1107	1768	340	394	1158
CHFM30	- 6255DB - (B) - Ratio	22	4	1603	340	394	1107	1768	340	394	1158
CHFM40	- 6255DB - (B) - Ratio	30	4	1603	340	394	1122	1768	340	394	1165
CHFM50	- 6255DB - (B) - Ratio	37	4	1718	340	394	1159	1928	340	394	1256
CHFM60	- 6255DB - (B) - Ratio	45	4	1718	340	394	1159	1928	340	394	1256
CHFM8	- 6265DA - (B) - Ratio	5.5	4	1480	168	212	1196	1552	168	212	1206
CHFM10	- 6265DA - (B) - Ratio	7.5	4	1493	213	251	1211	1588	213	251	1231
CHFM15	- 6265DA - (B) - Ratio	11	4	1553	213	251	1226	1648	213	251	1241
CHFM20	- 6265DA - (B) - Ratio	15	4	1618	261	324	1276	1723	261	324	1311
CHFM25	- 6265DA - (B) - Ratio	18.5	4	1713	340	394	1355	1878	340	394	1400
CHFM30	- 6265DA - (B) - Ratio	22	4	1713	340	394	1355	1878	340	394	1400
CHFM40	- 6265DA - (B) - Ratio	30	4	1713	340	394	1370	1878	340	394	1413
CHFM50	- 6265DA - (B) - Ratio	37	4	1828	340	394	1405	2043	340	394	1502
CHFM60	- 6265DA - (B) - Ratio	45	4	1828	340	394	1405	2043	340	394	1502

- Note: 1. □ indicates motor capacity.
 2. Dimension of shaft end diameter: Dimension tolerance conforms to JIS B 0401-1976 "h6."
 3. Dimension of shaft end key: Dimension tolerance conforms to JIS B 1301-1996 "Parallel Key."
 4. Pilot diameter ($\phi D3$) of CHFM type: Dimension tolerance conforms to JIS B 0401-1976 "g6."
 5. Pilot diameter ($\phi D3$) of CVVM type: Dimension tolerance conforms to JIS B 0401-1976 "f8."

Dimension Tables Gearmotors (Vertical, Slow Speed Shaft Down, V-Flange Mount)

CVVM^{Note 1} - 607□SK to 609□SK

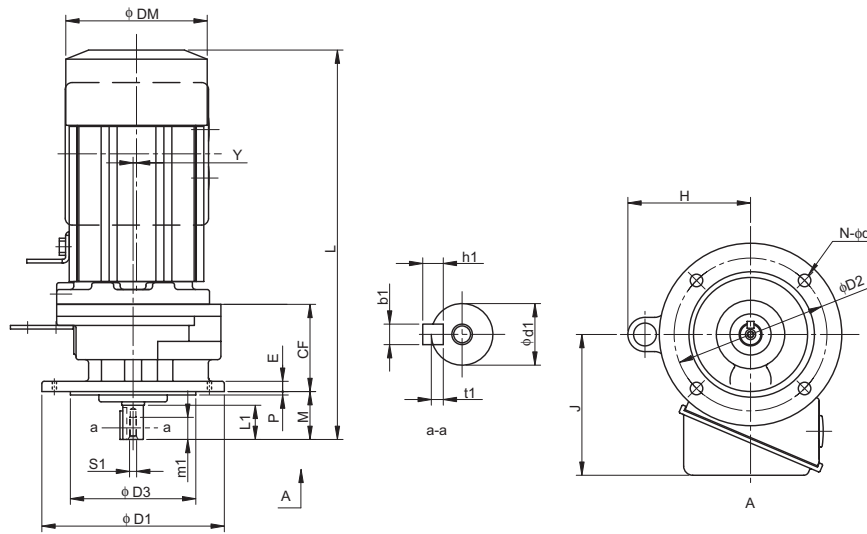

Dimension Tables
CVVM
GEARMOTORS

Frame size <small>Notes 6</small>	CF	D1	D2	D3	M	E	P	Y	N	d	H	Output Shaft <small>Notes 2, 3, 8</small>						
												d1	L1	b1	h1	t1	S1	m1
607□SK	77	160	134	110	42	9	3	0	4	11	-	18	30	6	6	3.5	M6	16
608□SK	92	160	134	110	48	9	3	0	4	11	-	22	35	6	6	3.5	M6	16
609□SK	118	160	134	110	48	9	3	0	4	11	107	28	35	8	7	4	M8	20

Model <small>Notes 6, 7</small>	Motor		Standard					With Brake			
	kW	P	L	J	DM	W(kg)	L	J	DM	W(kg)	
CVVM05 - 607□SK - (B) - Ratio	0.4	4	310	130	124	12	342	130	124	13	
CVVM08 - 607□SK - (B) - Ratio	0.55	4	350	140	148	15	394	140	148	17	
CVVM1 - 607□SK - (B) - Ratio	0.75	4	350	140	148	15	394	140	148	17	
CVVM05 - 608□SK - (B) - Ratio	0.4	4	336	130	124	13	368	130	124	14	
CVVM08 - 608□SK - (B) - Ratio	0.55	4	377	140	148	16	420	140	148	18	
CVVM1 - 608□SK - (B) - Ratio	0.75	4	377	140	148	16	420	140	148	18	
CVVM1H - 608□SK - (B) - Ratio	1.1	4	410	145	160	21	472	145	160	25	
CVVM2 - 608□SK - (B) - Ratio	1.5	4	410	145	160	21	472	145	160	25	
CVVM05 - 609□SK - (B) - Ratio	0.4	4	362	130	124	15	394	130	124	16	
CVVM08 - 609□SK - (B) - Ratio	0.55	4	403	140	148	18	446	140	148	20	
CVVM1 - 609□SK - (B) - Ratio	0.75	4	403	140	148	18	446	140	148	20	
CVVM1H - 609□SK - (B) - Ratio	1.1	4	436	145	160	23	498	145	160	27	
CVVM2 - 609□SK - (B) - Ratio	1.5	4	436	145	160	23	498	145	160	27	
CVVM3 - 609□SK - (B) - Ratio	2.2	4	456	152	173	27	519	152	173	33	

Note: 6. □ indicates 0 or 5, expressing combination with reduction ratio. Refer to the Selection Table for details.
 7. "B" after the frame size indicates models equipped with brake.
 8. Dimension of shaft end: Refer to pages F-28 to F-29 for details.
 9. Dimensions in above drawings are subject to change without notice.

Dimension Tables Gearmotors (Vertical, Slow Speed Shaft Down, V-Flange Mount)

CVVM^{Note 1} - 610□SK to 611□SK

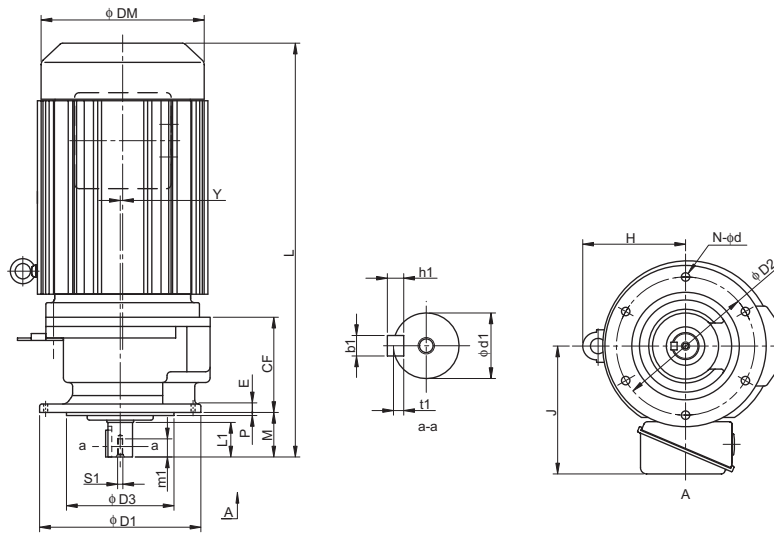

Frame size <small>Note 5</small>	CF	D1	D2	D3	M	E	P	Y	N	d	H	Output Shaft <small>Note 2, 3, 7</small>						
												d1	L1	b1	h1	t1	S1	m1
610□SK	122	160	134	110	48	9	3	0	4	11	116	28	35	8	7	4	M8	20
611□SK	124	210	180	140	58	11	4	3	6	11	134	32	45	10	8	5	M8	20

Model <small>Note 5, 6</small>	Motor		Standard				With Brake			
	kW	P	L	J	DM	W(kg)	L	J	DM	W(kg)
CVVM05 - 610□SK - (B) - Ratio	0.4	4	362	130	124	16	393	130	124	17
CVVM08 - 610□SK - (B) - Ratio	0.55	4	403	140	148	19	452	140	148	21
CVVM1 - 610□SK - (B) - Ratio	0.75	4	403	140	148	19	452	140	148	21
CVVM1H - 610□SK - (B) - Ratio	1.1	4	436	145	160	24	493	145	160	28
CVVM2 - 610□SK - (B) - Ratio	1.5	4	436	145	160	24	493	145	160	28
CVVM3 - 610□SK - (B) - Ratio	2.2	4	456	152	173	28	519	152	173	34
CVVM4 - 610□SK - (B) - Ratio	3	4	491	168	212	40	563	168	212	51
CVVM5 - 610□SK - (B) - Ratio	3.7	4	491	168	212	40	563	168	212	51
CVVM08 - 611□SK - (B) - Ratio	0.55	4	419	140	148	29	462	140	148	31
CVVM1 - 611□SK - (B) - Ratio	0.75	4	419	140	148	29	462	140	148	31
CVVM1H - 611□SK - (B) - Ratio	1.1	4	452	145	160	34	514	145	160	38
CVVM2 - 611□SK - (B) - Ratio	1.5	4	452	145	160	34	514	145	160	38
CVVM3 - 611□SK - (B) - Ratio	2.2	4	472	152	173	38	535	152	173	44
CVVM4 - 611□SK - (B) - Ratio	3	4	495	168	212	50	567	168	212	61
CVVM5 - 611□SK - (B) - Ratio	3.7	4	495	168	212	50	567	168	212	61
CVVM8 - 611□SK - (B) - Ratio	5.5	4	539	168	212	58	611	168	212	69

- Note: 1. □ indicates motor capacity.
 2. Dimension of shaft end diameter: Dimension tolerance conforms to JIS B 0401-1976 "h6."
 3. Dimension of shaft end key: Dimension tolerance conforms to JIS B 1301-1996 "Parallel Key."
 4. Pilot diameter ($\phi D3$): Dimension tolerance conforms to JIS B 0401-1976 "f8."

Dimension Tables Gearmotors (Universal Direction, V-Flange Mount)

CNVM^{Note 1} - 606□ to 609□

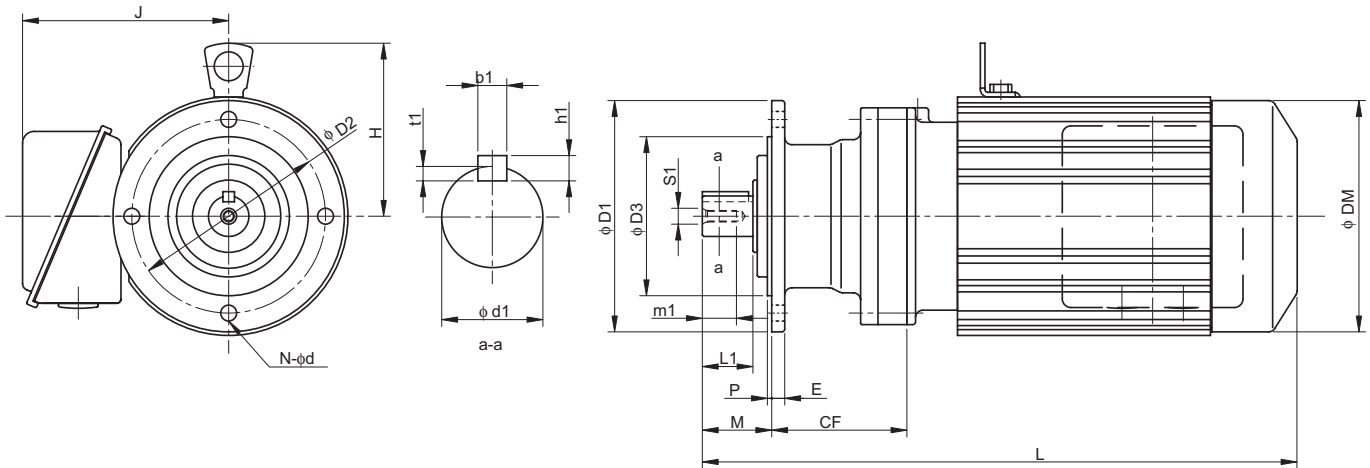

GEARMOTORS
Dimension Tables
CNVM

Frame size <small>Note 5</small>	CF	D1	D2	D3	M	E	P	N	d	H	Output Shaft <small>Note 2, 3, 7</small>						
											d1	L1	b1	h1	t1	S1	m1
606□	58	120	102	80	34	8	3	6	9	-	14	25	5	5	3	M5	16
607□	56	160	134	110	42	9	3	4	11	-	18	30	6	6	3.5	M6	16
608□	81	160	134	110	48	9	3	4	11	-	22	35	6	6	3.5	M6	16
609□	94	160	134	110	48	9	3	4	11	107	28	35	8	7	4	M8	20

Model <small>Note 5, 6</small>	Motor		Standard				With Brake			
	kW	P	L	J	DM	W(kg)	L	J	DM	W(kg)
CNVM01 - 606□ - (B) - Ratio	0.1	4	254	130	119	7	261	130	124	9
CNVM02 - 606□ - (B) - Ratio	0.2	4	272	130	124	8	300	130	124	10
CNVM03 - 606□ - (B) - Ratio	0.25	4	272	130	124	9	300	130	124	10
CNVM01 - 607□ - (B) - Ratio	0.1	4	260	130	119	9	267	130	124	10
CNVM02 - 607□ - (B) - Ratio	0.2	4	278	130	124	10	306	130	124	11
CNVM03 - 607□ - (B) - Ratio	0.25	4	278	130	124	10	306	130	124	11
CNVM05 - 607□ - (B) - Ratio	0.4	4	294	130	124	11	326	130	124	12
CNVM01 - 608□ - (B) - Ratio	0.1	4	286	130	119	12	293	130	124	13
CNVM02 - 608□ - (B) - Ratio	0.2	4	304	130	124	13	332	130	124	14
CNVM03 - 608□ - (B) - Ratio	0.25	4	304	130	124	13	332	130	124	14
CNVM05 - 608□ - (B) - Ratio	0.4	4	320	130	124	15	352	130	124	16
CNVM08 - 608□ - (B) - Ratio	0.55	4	361	140	148	19	404	140	148	20
CNVM1 - 608□ - (B) - Ratio	0.75	4	361	140	148	19	404	140	148	20
CNVM01 - 609□ - (B) - Ratio	0.1	4	304	130	119	13	311	130	124	15
CNVM02 - 609□ - (B) - Ratio	0.2	4	322	130	124	14	350	130	124	16
CNVM03 - 609□ - (B) - Ratio	0.25	4	322	130	124	14	350	130	124	16
CNVM05 - 609□ - (B) - Ratio	0.4	4	338	130	124	15	370	130	124	17
CNVM08 - 609□ - (B) - Ratio	0.55	4	379	140	148	19	422	140	148	22
CNVM1 - 609□ - (B) - Ratio	0.75	4	379	140	148	19	422	140	148	22
CNVM1H - 609□ - (B) - Ratio	1.1	4	412	145	160	22	474	145	160	27
CNVM2 - 609□ - (B) - Ratio	1.5	4	412	145	160	22	474	145	160	27

Note: 5. □ indicates 0 or 5, expressing combination with reduction ratio. Refer to the Selection Table for details.
 6. "B" after the frame size indicates models equipped with brake.
 7. Dimension of shaft end: Refer to pages F-28 to F-29 for details.
 8. Dimensions in above drawings are subject to change without notice.

Dimension Tables Gearmotors (Universal Direction, V-Flange Mount)

CNVM^{Note 1} - 610□ to 612□

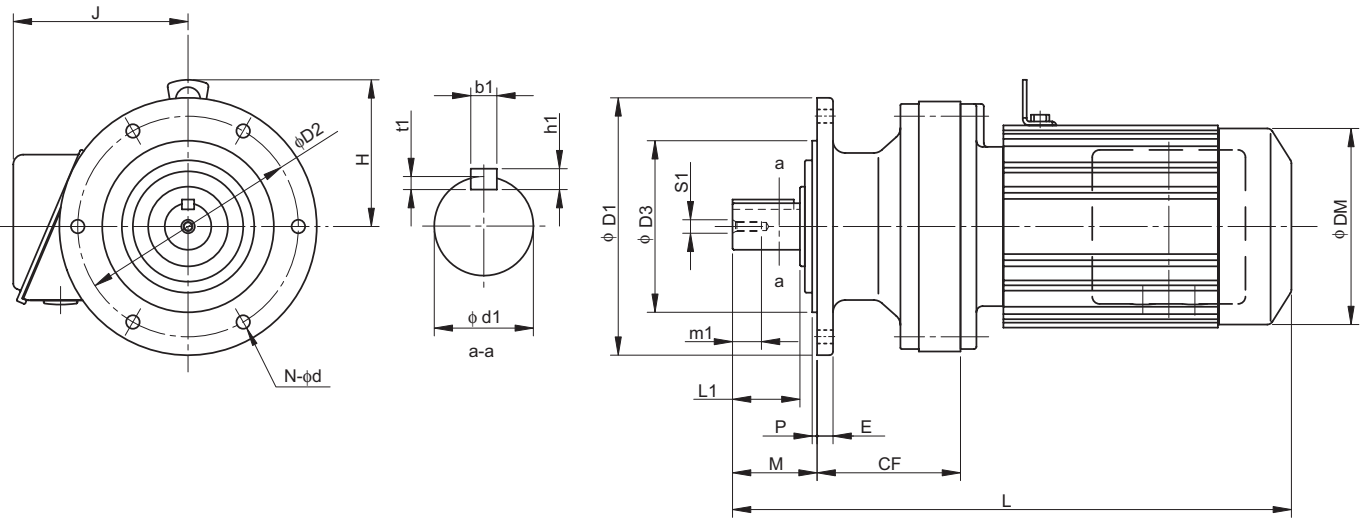

GEARMOTORS

Dimension Tables
CNVM

Frame size <small>Note 5</small>	CF	D1	D2	D3	M	E	P	N	d	H	Output Shaft <small>Note 2, 3, 7</small>						
											d1	L1	b1	h1	t1	S1	m1
610□	108	160	134	110	48	9	3	4	11	107	28	35	8	7	4	M8	20
611□	112	210	180	140	58	11	4	6	11	116	32	45	10	8	5	M8	20
612□	117	210	180	140	69	13	4	6	11	137	38	55	10	8	5	M8	20

Model <small>Note 5, 6</small>	Motor		Standard				With Brake			
	kW	P	L	J	DM	W(kg)	L	J	DM	W(kg)
CNVM02 -610□ - (B) - Ratio	0.2	4	336	130	124	16	364	130	124	18
CNVM03 -610□ - (B) - Ratio	0.25	4	336	130	124	16	364	130	124	18
CNVM05 -610□ - (B) - Ratio	0.4	4	352	130	124	17	384	130	124	19
CNVM08 -610□ - (B) - Ratio	0.55	4	393	140	148	21	436	140	148	24
CNVM1 -610□ - (B) - Ratio	0.75	4	393	140	148	21	436	140	148	24
CNVM1H -610□ - (B) - Ratio	1.1	4	426	145	160	25	488	145	160	30
CNVM2 -610□ - (B) - Ratio	1.5	4	426	145	160	25	488	145	160	30
CNVM3 -610□ - (B) - Ratio	2.2	4	446	152	173	29	509	152	173	35
CNVM05 -611□ - (B) - Ratio	0.4	4	363	130	124	19	394	130	124	21
CNVM08 -611□ - (B) - Ratio	0.55	4	403	140	148	22	452	140	148	25
CNVM1 -611□ - (B) - Ratio	0.75	4	403	140	148	22	452	140	148	25
CNVM1H -611□ - (B) - Ratio	1.1	4	436	145	160	25	493	145	160	30
CNVM2 -611□ - (B) - Ratio	1.5	4	436	145	160	25	493	145	160	30
CNVM3 -611□ - (B) - Ratio	2.2	4	456	152	173	29	519	152	173	35
CNVM4 -611□ - (B) - Ratio	3.0	4	491	168	212	39	563	168	212	49
CNVM5 -611□ - (B) - Ratio	3.7	4	491	168	212	39	563	168	212	49
CNVM05 -612□ - (B) - Ratio	0.4	4	387	130	124	30	419	130	124	31
CNVM08 -612□ - (B) - Ratio	0.55	4	423	140	148	31	466	140	148	34
CNVM1 -612□ - (B) - Ratio	0.75	4	423	140	148	31	466	140	148	34
CNVM1H -612□ - (B) - Ratio	1.1	4	456	145	160	35	518	145	160	40
CNVM2 -612□ - (B) - Ratio	1.5	4	456	145	160	35	518	145	160	40
CNVM3 -612□ - (B) - Ratio	2.2	4	476	152	173	39	539	152	173	46
CNVM4 -612□ - (B) - Ratio	3.0	4	499	168	212	49	571	168	212	59
CNVM5 -612□ - (B) - Ratio	3.7	4	499	168	212	49	571	168	212	59
CNVM8 -612□ - (B) - Ratio	5.5	4	543	168	212	56	615	168	212	66

- Note: 1. □ indicates motor capacity.
 2. Dimension of shaft end diameter: Dimension tolerance conforms to JIS B 0401-1976 "h6."
 3. Dimension of shaft end key: Dimension tolerance conforms to JIS B 1301-1996 "Parallel Key."
 4. Pilot diameter ($\phi D3$): Dimension tolerance conforms to JIS B 0401-1976 "f8."

Dimension Tables Gearmotors (Vertical, Slow Speed Shaft Down, V-Flange Mount)

CVVM^{Note 1} - 613□ to 614□

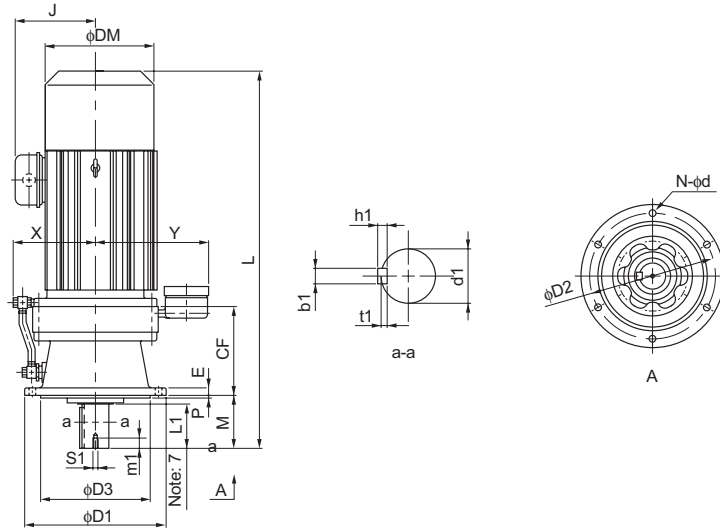

GEARMOTORS
Dimension Tables
CVVM

Frame size <small>Note 5</small>	CF	D1	D2	D3	M	E	P	N	d	X	Y	Output Shaft <small>Note 2, 3, 7</small>						
												d1	L1	b1	h1	t1	S1	m1
613□	164	260	230	200	76	15	4	6	11	152	233	50	61	14	9	5.5	M10	18
614□	164	260	230	200	96	15	4	6	11	152	233	50	81	14	9	5.5	M10	18

Model <small>Note 5, 6</small>	Motor		Standard				With Brake			
	kW	P	L	J	DM	W(kg)	L	J	DM	W(kg)
CVVM08 - 613□ - (B) - Ratio	0.55	4	477	140	148	51	520	140	148	54
CVVM1 - 613□ - (B) - Ratio	0.75	4	477	140	148	51	520	140	148	54
CVVM1H - 613□ - (B) - Ratio	1.1	4	510	145	160	55	572	145	160	60
CVVM2 - 613□ - (B) - Ratio	1.5	4	510	145	160	55	572	145	160	60
CVVM3 - 613□ - (B) - Ratio	2.2	4	530	152	173	58	593	152	173	65
CVVM4 - 613□ - (B) - Ratio	3.0	4	553	168	212	68	625	168	212	78
CVVM5 - 613□ - (B) - Ratio	3.7	4	553	168	212	68	625	168	212	78
CVVM8 - 613□ - (B) - Ratio	5.5	4	597	168	212	75	669	168	212	85
CVVM10 - 613□ - (B) - Ratio	7.5	4	620	213	251	90	715	213	251	108
CVVM15 - 613□ - (B) - Ratio	11	4	680	213	251	104	775	213	251	121
CVVM1 - 614□ - (B) - Ratio	0.75	4	497	140	148	52	540	140	148	55
CVVM1H - 614□ - (B) - Ratio	1.1	4	530	145	160	56	592	145	160	61
CVVM2 - 614□ - (B) - Ratio	1.5	4	530	145	160	56	592	145	160	61
CVVM3 - 614□ - (B) - Ratio	2.2	4	550	152	173	59	613	152	173	66
CVVM4 - 614□ - (B) - Ratio	3.0	4	573	168	212	69	645	168	212	79
CVVM5 - 614□ - (B) - Ratio	3.7	4	573	168	212	69	645	168	212	79
CVVM8 - 614□ - (B) - Ratio	5.5	4	617	168	212	76	689	168	212	86
CVVM10 - 614□ - (B) - Ratio	7.5	4	640	213	251	91	735	213	251	109
CVVM15 - 614□ - (B) - Ratio	11	4	700	213	251	104	795	213	251	122
CVVM20 - 614□ - (B) - Ratio	15	4	790	261	324	156	895	261	324	190

Note: 5. □ indicates 0 or 5, expressing combination with reduction ratio. Refer to the Selection Table for details.
 6. "B" after the frame size indicates models equipped with brake.
 7. Dimension of shaft end: Refer to pages F-28 to F-29 for details.
 8. Dimensions in above drawings are subject to change without notice.

Dimension Tables Gearmotors (Vertical, Slow Speed Shaft Down, V-Flange Mount)

CVVM^{Note 1} - 616□ to 617□

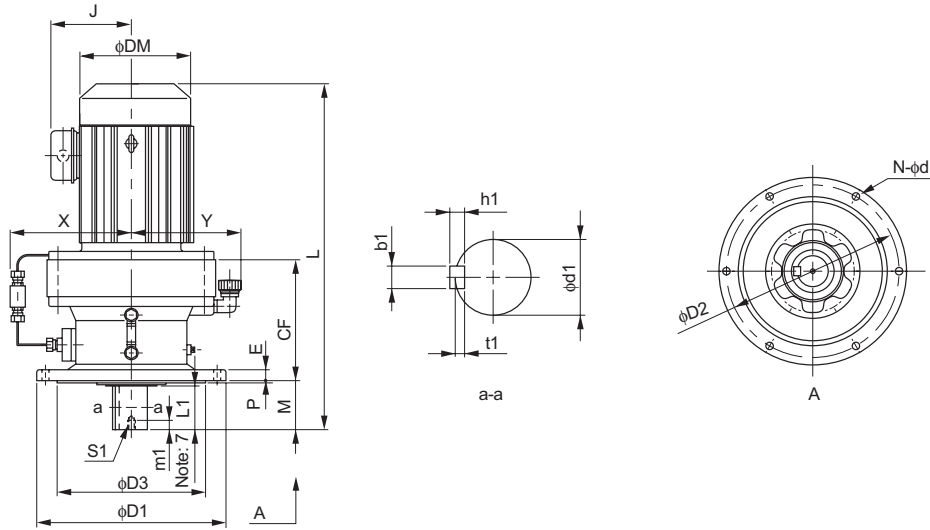

GEARMOTORS

Dimension Tables
CVVM

Frame size <small>Note 5</small>	CF	D1	D2	D3	M	E	P	N	d	X	Y	Output Shaft <small>Note 2, 3, 7</small>						
												d1	L1	b1	h1	t1	S1	m1
616□	219	340	310	270	89	20	4	6	11	217	200	60	80	18	11	7	M10	18
617□	258	400	360	316	94	22	5	8	14	222	225	70	84	20	12	7.5	M12	24

Model <small>Note 5, 6</small>	Motor		Standard				With Brake			
	kW	P	L	J	DM	W(kg)	L	J	DM	W(kg)
CVVM1H - 616□	- (B) - Ratio	1.1 4	583	145	160	89	645	145	160	94
CVVM2 - 616□	- (B) - Ratio	1.5 4	583	145	160	89	645	145	160	94
CVVM3 - 616□	- (B) - Ratio	2.2 4	598	152	173	92	661	152	173	98
CVVM4 - 616□	- (B) - Ratio	3.0 4	621	168	212	101	693	168	212	111
CVVM5 - 616□	- (B) - Ratio	3.7 4	621	168	212	101	693	168	212	111
CVVM8 - 616□	- (B) - Ratio	5.5 4	665	168	212	108	737	168	212	118
CVVM10 - 616□	- (B) - Ratio	7.5 4	693	213	251	124	788	213	251	141
CVVM15 - 616□	- (B) - Ratio	11 4	753	213	251	138	848	213	251	155
CVVM20 - 616□	- (B) - Ratio	15 4	838	261	324	191	943	261	324	225
CVVM25 - 616□	- (B) - Ratio	18.5 4	933	340	394	267	1098	340	394	318
CVVM30 - 616□	- (B) - Ratio	22 4	933	340	394	267	1098	340	394	318
CVVM4 - 617□	- (B) - Ratio	3.0 4	680	168	212	144	752	168	212	154
CVVM5 - 617□	- (B) - Ratio	3.7 4	680	168	212	144	752	168	212	154
CVVM8 - 617□	- (B) - Ratio	5.5 4	724	168	212	151	796	168	212	161
CVVM10 - 617□	- (B) - Ratio	7.5 4	742	213	251	166	837	213	251	184
CVVM15 - 617□	- (B) - Ratio	11 4	802	213	251	180	897	213	251	198
CVVM20 - 617□	- (B) - Ratio	15 4	882	261	324	234	987	261	324	268
CVVM25 - 617□	- (B) - Ratio	18.5 4	977	340	394	306	1142	340	324	357
CVVM30 - 617□	- (B) - Ratio	22 4	977	340	394	306	1142	340	324	357
CVVM40 - 617□	- (B) - Ratio	30 4	977	340	394	323	1142	340	324	366

- Note: 1. □ indicates motor capacity.
 2. Dimension of shaft end diameter: Dimension tolerance conforms to JIS B 0401-1976 "h6."
 3. Dimension of shaft end key: Dimension tolerance conforms to JIS B 1301-1996 "Parallel Key."
 4. Pilot diameter (ϕ_{D3}): Dimension tolerance conforms to JIS B 0401-1976 "f8."

Dimension Tables Gearmotors (Vertical, Slow Speed Shaft Down, V-Flange Mount)

CVVM^{Note 1} - 618□ to 619□

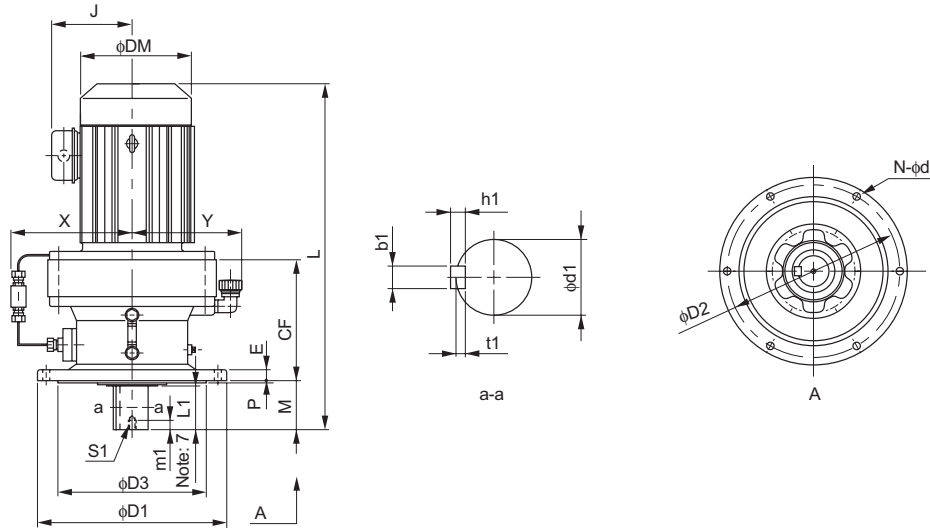

GEARMOTORS
Dimension Tables
CVVM

Frame size <small>Note 5</small>	CF	D1	D2	D3	M	E	P	N	d	X	Y	Output Shaft <small>Note 2, 3, 7</small>						
												d1	L1	b1	h1	t1	S1	m1
618□	279	430	390	345	110	22	5	8	18	237	240	80	100	22	14	9	M12	24
619□	320	490	450	400	145	30	6	12	18	265	270	95	125	25	14	9	M20	34

Model <small>Note 5, 6</small>	Motor		Standard				With Brake			
	kW	P	L	J	DM	W(kg)	L	J	DM	W(kg)
CVVM4 - 618□ - (B) - Ratio	3.0	4	717	168	212	170	789	168	212	180
CVVM5 - 618□ - (B) - Ratio	3.7	4	717	168	212	170	789	168	212	180
CVVM8 - 618□ - (B) - Ratio	5.5	4	761	168	212	178	833	168	212	188
CVVM10 - 618□ - (B) - Ratio	7.5	4	779	213	251	193	874	213	251	211
CVVM15 - 618□ - (B) - Ratio	11	4	839	213	251	207	934	213	251	225
CVVM20 - 618□ - (B) - Ratio	15	4	919	261	324	267	1024	261	324	296
CVVM25 - 618□ - (B) - Ratio	18.5	4	1014	340	394	333	1179	340	394	384
CVVM30 - 618□ - (B) - Ratio	22	4	1014	340	394	333	1179	340	394	384
CVVM40 - 618□ - (B) - Ratio	30	4	1014	340	394	350	1179	340	394	393
CVVM50 - 618□ - (B) - Ratio	37	4	1129	340	394	398	1344	340	394	495
CVVM60 - 618□ - (B) - Ratio	45	4	1129	340	394	398	1344	340	394	495
CVVM8 - 619□ - (B) - Ratio	5.5	4	857	168	212	250	929	168	212	260
CVVM10 - 619□ - (B) - Ratio	7.5	4	870	213	251	263	965	213	251	281
CVVM15 - 619□ - (B) - Ratio	11	4	930	213	251	277	1025	213	251	295
CVVM20 - 619□ - (B) - Ratio	15	4	995	261	324	330	1100	261	324	365
CVVM25 - 619□ - (B) - Ratio	18.5	4	1090	340	394	408	1255	340	394	453
CVVM256 - 619□ - (B) - Ratio	18.5	6	1090	340	394	421	1255	340	394	466
CVVM30 - 619□ - (B) - Ratio	22	4	1090	340	394	408	1255	340	394	453
CVVM40 - 619□ - (B) - Ratio	30	4	1090	340	394	421	1255	340	394	466
CVVM406 - 619□ - (B) - Ratio	30	6	1205	340	394	459	1420	340	394	556
CVVM50 - 619□ - (B) - Ratio	37	4	1205	340	394	459	1420	340	394	556
CVVM506 - 619□ - (B) - Ratio	37	6	1205	340	394	459	1420	340	394	556
CVVM60 - 619□ - (B) - Ratio	45	4	1205	340	394	459	1420	340	394	556

Note: 5. □ indicates 0 or 5, expressing combination with reduction ratio. Refer to the Selection Table for details.
 6. "B" after the frame size indicates models equipped with brake.
 7. Dimension of shaft end: Refer to pages F-28 to F-29 for details.
 8. Dimensions in above drawings are subject to change without notice.

Dimension Tables Gearmotors (Vertical, Slow Speed Shaft Down, V-Flange Mount)

CVVM^{Note 1} - 6205 to 6215

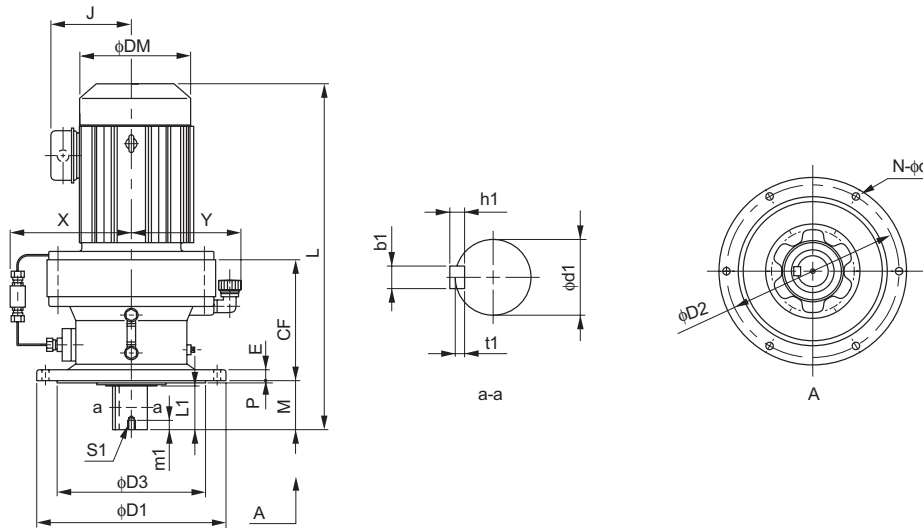

Frame size	CF	D1	D2	D3	M	E	P	N	d	X	Y	Output Shaft <small>Note 2, 3, 6</small>						
												d1	L1	b1	h1	t1	S1	m1
6205	298	455	405	355	204	30	5	8	22	341	287	100	165	28	16	10	M20	34
6215	323	490	440	390	203	35	7	8	24	348	306	110	165	28	16	10	M20	34

Model	Note 5	Motor		Standard				With Brake			
		kW	P	L	J	DM	W(kg)	L	J	DM	W(kg)
CVVM15 - 6205	- (B) - Ratio	11	4	972	213	251	299	1067	213	251	317
CVVM20 - 6205	- (B) - Ratio	15	4	1042	261	324	353	1147	261	324	389
CVVM206 - 6205	- (B) - Ratio	15	6	1127	340	394	428	1292	340	394	473
CVVM25 - 6205	- (B) - Ratio	18.5	4	1127	340	394	428	1292	340	394	473
CVVM30 - 6205	- (B) - Ratio	22	4	1127	340	394	428	1292	340	394	473
CVVM306 - 6205	- (B) - Ratio	22	6	1127	340	394	441	1292	340	394	486
CVVM40 - 6205	- (B) - Ratio	30	4	1127	340	394	441	1292	340	394	486
CVVM406 - 6205	- (B) - Ratio	30	6	1242	340	394	479	1457	340	394	573
CVVM50 - 6205	- (B) - Ratio	37	4	1242	340	394	479	1457	340	394	573
CVVM506 - 6205	- (B) - Ratio	37	6	1242	340	394	479	1457	340	394	573
CVVM60 - 6205	- (B) - Ratio	45	4	1242	340	394	479	1457	340	394	573
CVVM606 - 6205	- (B) - Ratio	45	6	1297	390	484	572	-	-	-	-
CVVM75 - 6205	- (B) - Ratio	55	4	1297	390	484	572	-	-	-	-
CVVM15 - 6215	- (B) - Ratio	11	4	996	213	251	377	1091	213	251	395
CVVM20 - 6215	- (B) - Ratio	15	4	1066	261	324	432	1171	261	324	467
CVVM206 - 6215	- (B) - Ratio	15	6	1151	340	394	501	1316	340	394	546
CVVM25 - 6215	- (B) - Ratio	18.5	4	1151	340	394	501	1316	340	394	546
CVVM256 - 6215	- (B) - Ratio	18.5	6	1151	340	394	514	1316	340	394	559
CVVM30 - 6215	- (B) - Ratio	22	4	1151	340	394	501	1316	340	394	546
CVVM306 - 6215	- (B) - Ratio	22	6	1151	340	394	514	1316	340	394	559
CVVM40 - 6215	- (B) - Ratio	30	4	1151	340	394	514	1316	340	394	559
CVVM406 - 6215	- (B) - Ratio	30	6	1266	340	394	569	1481	340	394	664
CVVM50 - 6215	- (B) - Ratio	37	4	1266	340	394	569	1481	340	394	664
CVVM506 - 6215	- (B) - Ratio	37	6	1266	340	394	569	1481	340	394	664
CVVM60 - 6215	- (B) - Ratio	45	4	1266	340	394	569	1481	340	394	664
CVVM606 - 6215	- (B) - Ratio	45	6	1321	390	484	662	-	-	-	-
CVVM75 - 6215	- (B) - Ratio	55	4	1321	390	484	662	-	-	-	-

- Note: 1. □ indicates motor capacity.
 2. Dimension of shaft end diameter: Dimension tolerance conforms to JIS B 0401-1976 "h6."
 3. Dimension of shaft end key: Dimension tolerance conforms to JIS B 1301-1996 "Parallel Key."
 4. Pilot diameter (φD3): Dimension tolerance conforms to JIS B 0401-1976 "f8."

Dimension Tables Gearmotors (Vertical, Slow Speed Shaft Down, V-Flange Mount)

CVVM^{Note 1} - 6225 to 6235

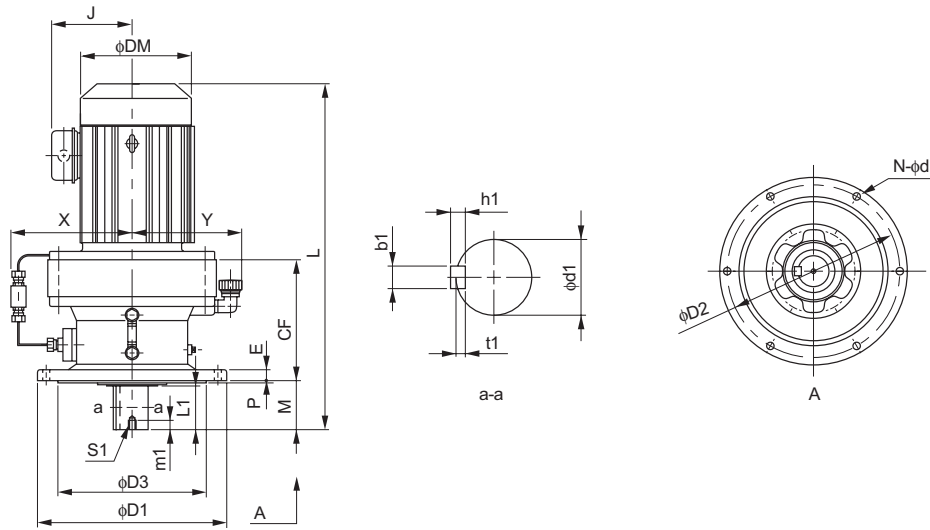

GEARMOTORS
Dimension Tables
CVVM

Frame size	CF	D1	D2	D3	M	E	P	N	d	X	Y	Output Shaft Note 2, 3, 6						
												d1	L1	b1	h1	t1	S1	m1
6225	356	535	475	415	210	35	10	8	27	352	326	120	165	32	18	11	M20	34
6235	378	570	510	450	250	40	10	8	27	359	344	130	200	32	18	11	M24	41

Model	Note 5	Motor		Standard				With Brake			
		kW	P	L	J	DM	W(kg)	L	J	DM	W(kg)
CVVM206 - 6225	- (B) - Ratio	15	6	1191	340	394	593	1356	340	394	638
CVVM25 - 6225	- (B) - Ratio	18.5	4	1191	340	394	593	1356	340	394	638
CVVM256 - 6225	- (B) - Ratio	18.5	6	1191	340	394	606	1356	340	394	651
CVVM30 - 6225	- (B) - Ratio	22	4	1191	340	394	593	1356	340	394	638
CVVM306 - 6225	- (B) - Ratio	22	6	1191	340	394	606	1356	340	394	651
CVVM40 - 6225	- (B) - Ratio	30	4	1191	340	394	606	1356	340	394	651
CVVM406 - 6225	- (B) - Ratio	30	6	1306	340	394	660	1521	340	394	755
CVVM50 - 6225	- (B) - Ratio	37	4	1306	340	394	660	1521	340	394	755
CVVM506 - 6225	- (B) - Ratio	37	6	1306	340	394	660	1521	340	394	755
CVVM60 - 6225	- (B) - Ratio	45	4	1306	340	394	660	1521	340	394	755
CVVM606 - 6225	- (B) - Ratio	45	6	1361	390	484	743	-	-	-	-
CVVM75 - 6225	- (B) - Ratio	55	4	1361	390	484	743	-	-	-	-
CVVM206 - 6235	- (B) - Ratio	15	6	1253	340	394	653	1418	340	394	684
CVVM256 - 6235	- (B) - Ratio	18.5	6	1253	340	394	653	1418	340	394	698
CVVM306 - 6235	- (B) - Ratio	22	6	1253	340	394	653	1418	340	394	698
CVVM406 - 6235	- (B) - Ratio	30	6	1368	340	394	699	1583	340	394	787
CVVM506 - 6235	- (B) - Ratio	37	6	1368	340	394	699	1583	340	394	787
CVVM606 - 6235	- (B) - Ratio	45	6	1423	390	484	788	-	-	-	-
CVVM756 - 6235	- (B) - Ratio	55	6	1503	390	485	842	-	-	-	-

Note: 5. "B" after the frame size indicates models equipped with brake.
6. Dimension of shaft end: Refer to pages F-28 to F-29 for details.
7. Dimensions in above drawings are subject to change without notice.

Dimension Tables Gearmotors (Vertical, Slow Speed Shaft Down, V-Flange Mount)

CVVM^{Note 1} - 6245 to 6265

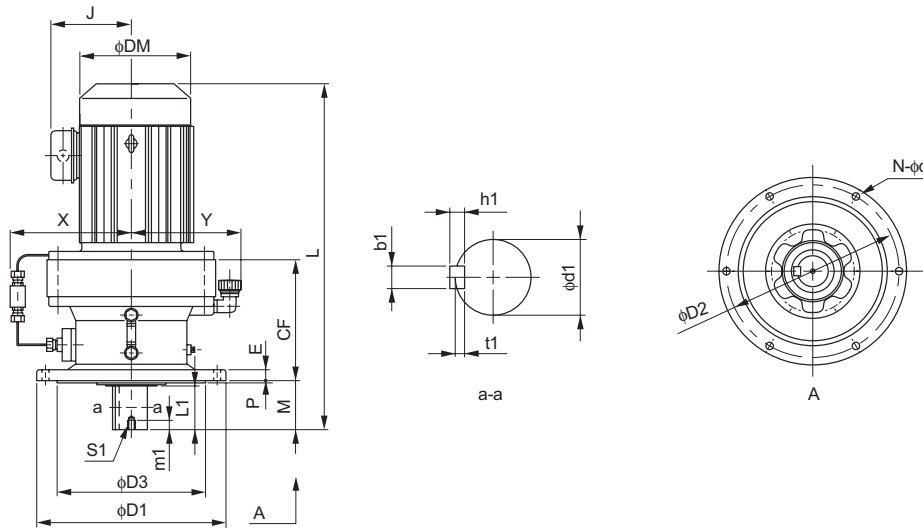

Frame size	CF	D1	D2	D3	M	E	P	N	d	X	Y	Output Shaft Note 2, 3, 7						
												d1	L1	b1	h1	t1	S1	m1
6245	407	635	560	485	250	40	10	8	33	370	371	140	200	36	20	12	M24	41
6255	480	685	610	535	295	45	10	8	33	426	399	160	240	40	22	13	M30	49
6265	532	750	660	570	360	50	10	8	39	460	431	170	300	40	22	13	M30	49

Model	Note 6	Motor		Standard				With Brake			
		kW	P	L	J	DM	W(kg)	L	J	DM	W(kg)
CVVM206 - 6245	- (B) - Ratio	15	6	1282	340	394	759	1447	340	394	792
CVVM256 - 6245	- (B) - Ratio	18.5	6	1282	340	394	759	1447	340	394	806
CVVM306 - 6245	- (B) - Ratio	22	6	1282	340	394	759	1447	340	394	806
CVVM406 - 6245	- (B) - Ratio	30	6	1397	340	394	805	1612	340	394	893
CVVM506 - 6245	- (B) - Ratio	37	6	1397	340	394	805	1612	340	394	893
CVVM606 - 6245	- (B) - Ratio	45	6	1452	390	484	896	-	-	-	-
CVVM756 - 6245	- (B) - Ratio	55	6	1532	390	485	945	-	-	-	-
CVVM206 - 6255	- (B) - Ratio	15	6	1400	340	394	1045	1565	340	394	1123
CVVM256 - 6255	- (B) - Ratio	18.5	6	1400	340	394	1045	1565	340	394	1137
CVVM306 - 6255	- (B) - Ratio	22	6	1400	340	394	1045	1565	340	394	1137
CVVM406 - 6255	- (B) - Ratio	30	6	1515	340	394	1090	1730	340	394	1178
CVVM506 - 6255	- (B) - Ratio	37	6	1515	340	394	1090	1730	340	394	1178
CVVM606 - 6255	- (B) - Ratio	45	6	1570	390	484	1170	-	-	-	-
CVVM756 - 6255	- (B) - Ratio	55	6	1650	390	485	1225	-	-	-	-
CVVM406 - 6265	- (B) - Ratio	22	6	1517	340	394	1350	1727	340	394	1397
CVVM406 - 6265	- (B) - Ratio	30	6	1632	340	394	1395	1847	340	394	1483
CVVM506 - 6265	- (B) - Ratio	37	6	1632	340	394	1395	1847	340	394	1483
CVVM606 - 6265	- (B) - Ratio	45	6	1687	390	484	1490	-	-	-	-

- Note: 1. □ indicates motor capacity.
 2. Dimension of shaft end diameter: Dimension tolerance conforms to JIS B 0401-1976 "h6."
 3. Dimension of shaft end key: Dimension tolerance conforms to JIS B 1301-1996 "Parallel Key."
 4. Pilot diameter (φD3): Dimension tolerance conforms to JIS B 0401-1976 "f8."

Dimension Tables Gearmotors (Universal Direction, V-Flange Mount)

CNVM^{Note 1} - 606□DA to 612□DB

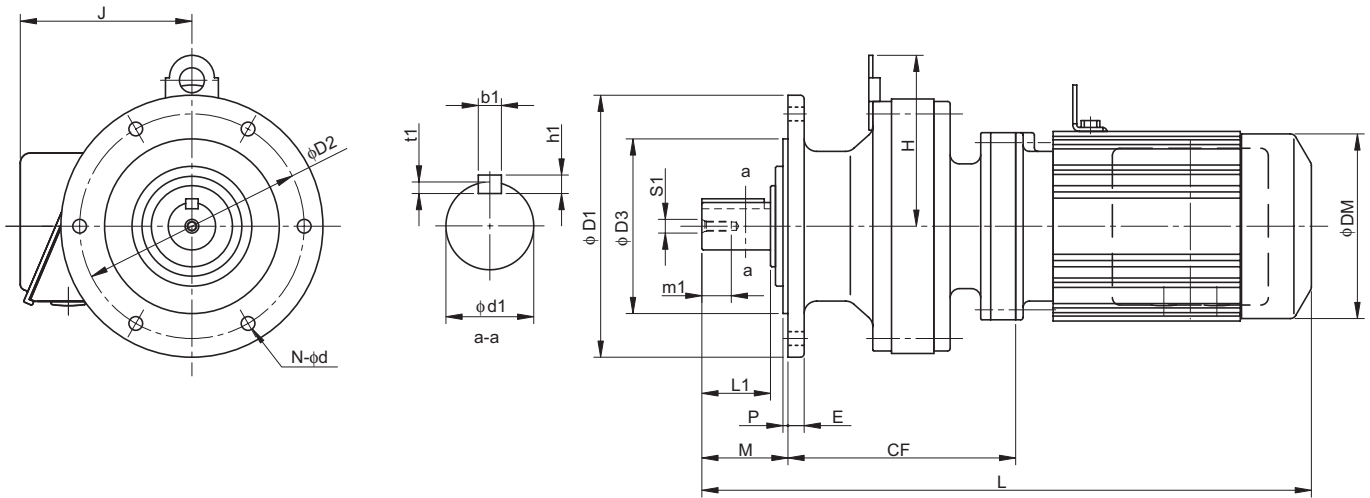

GEARMOTORS
Dimension Tables
CVVM

Frame size <small>Note 5</small>	CF	D1	D2	D3	M	E	P	N	d	H	Output Shaft <small>Note 2, 3, 7</small>						
											d1	L1	b1	h1	t1	S1	m1
606□DA	91	120	102	80	34	8	3	6	9	-	14	25	5	5	3	M5	16
607□DA	89	160	134	110	42	9	3	4	11	-	18	30	6	6	3.5	M6	16
609□DA	142	160	134	110	48	9	3	4	11	107	28	35	8	7	4	M8	20
610□DA	156	160	134	110	48	9	3	4	11	107	28	35	8	7	4	M8	20
612□DA	171	210	180	140	69	13	4	6	11	137	38	55	10	8	5	M8	20
612□DB	183	210	180	140	69	13	4	6	11	-	38	55	10	8	5	M8	20

Model <small>Note 5, 6</small>	Motor		Standard				With Brake			
	kW	P	L	J	DM	W(kg)	L	J	DM	W(kg)
CNVM01 - 606□DA - (B) - Ratio	0.1	4	287	130	119	9	294	130	124	12
CNVM01 - 607□DA - (B) - Ratio	0.1	4	293	130	119	9	300	130	124	12
CNVM02 - 607□DA - (B) - Ratio	0.2	4	311	130	124	10	339	130	124	13
CNVM01 - 609□DA - (B) - Ratio	0.1	4	352	130	119	16	359	130	124	17
CNVM02 - 609□DA - (B) - Ratio	0.2	4	370	130	124	17	398	130	124	18
CNVM03 - 609□DA - (B) - Ratio	0.25	4	370	130	124	17	398	130	124	18
CNVM05 - 609□DA - (B) - Ratio	0.4	4	386	130	124	18	418	130	124	19
CNVM01 - 610□DA - (B) - Ratio	0.1	4	366	130	119	17	373	130	124	18
CNVM02 - 610□DA - (B) - Ratio	0.2	4	384	130	124	18	412	130	124	19
CNVM03 - 610□DA - (B) - Ratio	0.25	4	384	130	124	18	412	130	124	19
CNVM05 - 610□DA - (B) - Ratio	0.4	4	400	130	124	19	432	130	124	20
CNVM01 - 612□DA - (B) - Ratio	0.1	4	402	130	119	29	409	130	124	30
CNVM02 - 612□DA - (B) - Ratio	0.2	4	420	130	124	30	448	130	124	31
CNVM03 - 612□DA - (B) - Ratio	0.25	4	420	130	124	30	448	130	124	31
CNVM05 - 612□DA - (B) - Ratio	0.4	4	436	130	124	31	468	130	124	32
CNVM01 - 612□DB - (B) - Ratio	0.1	4	414	130	119	32	421	130	124	34
CNVM02 - 612□DB - (B) - Ratio	0.2	4	432	130	124	33	473	130	124	35
CNVM03 - 612□DB - (B) - Ratio	0.25	4	432	130	124	33	473	130	124	35
CNVM05 - 612□DB - (B) - Ratio	0.4	4	448	130	124	34	473	130	124	36
CNVM08 - 612□DB - (B) - Ratio	0.55	4	489	140	148	38	532	140	148	41
CNVM1 - 612□DB - (B) - Ratio	0.75	4	489	140	148	38	532	140	148	41
CNVM1H - 612□DB - (B) - Ratio	1.1	4	516	145	160	42	578	145	160	47
CNVM2 - 612□DB - (B) - Ratio	1.5	4	516	145	160	42	578	145	160	47

Note: 5. □ indicates 0 or 5, expressing combination with reduction ratio. Refer to the Selection Table for details.
 6. "B" after the frame size indicates models equipped with brake.
 7. Dimension of shaft end: Refer to pages F-28 to F-29 for details.
 8. Dimensions in above drawings are subject to change without notice.

Dimension Tables Gearmotors (Vertical, Slow Speed Shaft Down, V-Flange Mount)

CVVM^{Note 1} - 613□DA to 614□DC

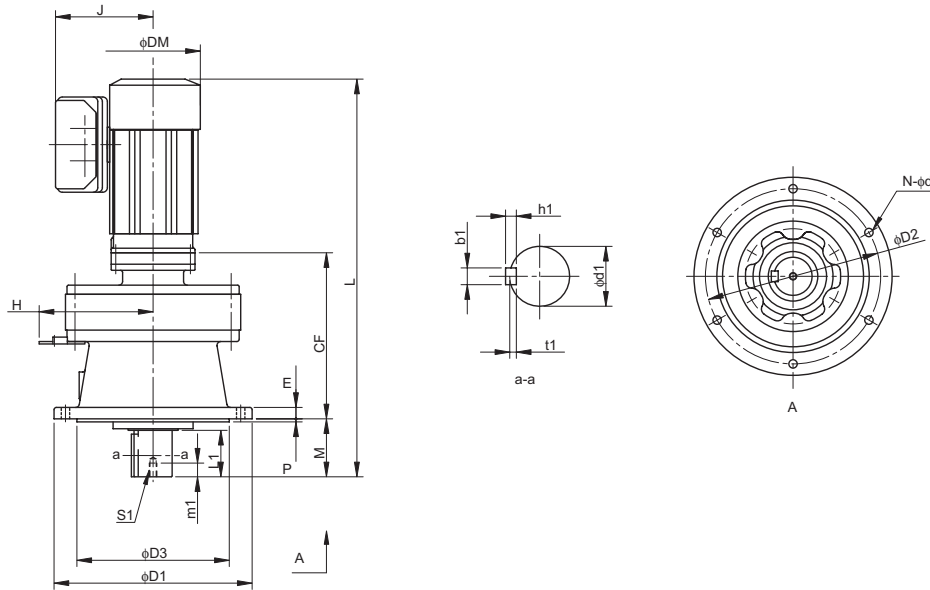

Frame size <small>Note 5</small>	CF	D1	D2	D3	M	E	P	N	d	H	Output Shaft <small>Note 2, 3, 7</small>						
											d1	L1	b1	h1	t1	S1	m1
613□DA	218	260	230	200	76	15	4	6	11	150	50	61	14	9	5.5	M10	18
613□DB	227	260	230	200	76	15	4	6	11	150	50	61	14	9	5.5	M10	18
613□DC	241	260	230	200	76	15	4	6	11	-	50	61	14	9	5.5	M10	18
614□DA	218	260	230	200	96	15	4	6	11	150	50	81	14	9	5.5	M10	18
614□DB	227	260	230	200	96	15	4	6	11	150	50	81	14	9	5.5	M10	18
614□DC	241	260	230	200	96	15	4	6	11	-	50	81	14	9	5.5	M10	18

Model <small>Note 5, 6</small>	Motor		Standard				With Brake			
	kW	P	L	J	DM	W(kg)	L	J	DM	W(kg)
CVVM02 - 613□DA - (B) - Ratio	0.2	4	474	130	124	45	502	130	124	45
CVVM03 - 613□DA - (B) - Ratio	0.25	4	494	130	124	45	522	130	124	45
CVVM05 - 613□DA - (B) - Ratio	0.4	4	490	130	124	48	522	130	124	49
CVVM02 - 613□DB - (B) - Ratio	0.2	4	483	130	124	48	511	130	124	50
CVVM03 - 613□DB - (B) - Ratio	0.25	4	483	130	124	48	511	130	124	50
CVVM05 - 613□DB - (B) - Ratio	0.4	4	499	130	124	49	531	130	124	51
CVVM08 - 613□DB - (B) - Ratio	0.55	4	540	140	148	53	583	140	148	56
CVVM1 - 613□DB - (B) - Ratio	0.75	4	540	140	148	53	583	140	148	56
CVVM1H - 613□DB - (B) - Ratio	1.1	4	573	145	160	57	635	145	160	62
CVVM2 - 613□DB - (B) - Ratio	1.5	4	573	145	160	57	635	145	160	62
CVVM08 - 613□DC - (B) - Ratio	0.55	4	554	140	148	56	597	140	148	59
CVVM1 - 613□DC - (B) - Ratio	0.75	4	554	140	148	56	597	140	148	59
CVVM2 - 613□DC - (B) - Ratio	1.5	4	587	145	160	60	649	145	160	65
CVVM3 - 613□DC - (B) - Ratio	2.2	4	607	152	173	64	670	152	173	70
CVVM02 - 614□DA - (B) - Ratio	0.2	4	494	123	124	45	522	123	124	46
CVVM03 - 614□DA - (B) - Ratio	0.25	4	494	123	124	45	522	123	124	46
CVVM05 - 614□DA - (B) - Ratio	0.4	4	510	123	124	48	542	123	124	49
CVVM02 - 614□DB - (B) - Ratio	0.2	4	503	123	124	48	531	123	124	50
CVVM03 - 614□DB - (B) - Ratio	0.25	4	503	123	124	48	531	123	124	50
CVVM05 - 614□DB - (B) - Ratio	0.4	4	519	123	124	49	551	123	124	51
CVVM08 - 614□DB - (B) - Ratio	0.55	4	560	140	148	53	603	140	148	56
CVVM1 - 614□DB - (B) - Ratio	0.75	4	560	140	148	53	603	140	148	56
CVVM1H - 614□DB - (B) - Ratio	1.1	4	593	145	160	57	655	145	160	62
CVVM2 - 614□DB - (B) - Ratio	1.5	4	593	145	160	57	655	145	160	62
CVVM08 - 614□DC - (B) - Ratio	0.55	4	574	140	148	54	617	140	148	57
CVVM1 - 614□DC - (B) - Ratio	0.75	4	574	140	148	54	617	140	148	57
CVVM1H - 614□DC - (B) - Ratio	1.1	4	607	145	160	58	669	145	160	63
CVVM2 - 614□DC - (B) - Ratio	1.5	4	607	145	160	58	669	145	160	63
CVVM3 - 614□DC - (B) - Ratio	2.2	4	627	152	173	62	690	152	173	68

- Note: 1. □ indicates motor capacity.
 2. Dimension of shaft end diameter: Dimension tolerance conforms to JIS B 0401-1976 "h6."
 3. Dimension of shaft end key: Dimension tolerance conforms to JIS B 1301-1996 "Parallel Key."
 4. Pilot diameter (φD3): Dimension tolerance conforms to JIS B 0401-1976 "f8."

Dimension Tables Gearmotors (Vertical, Slow Speed Shaft Down, V-Flange Mount)

CVVM^{Note 1} - 616□DA to 618□DA

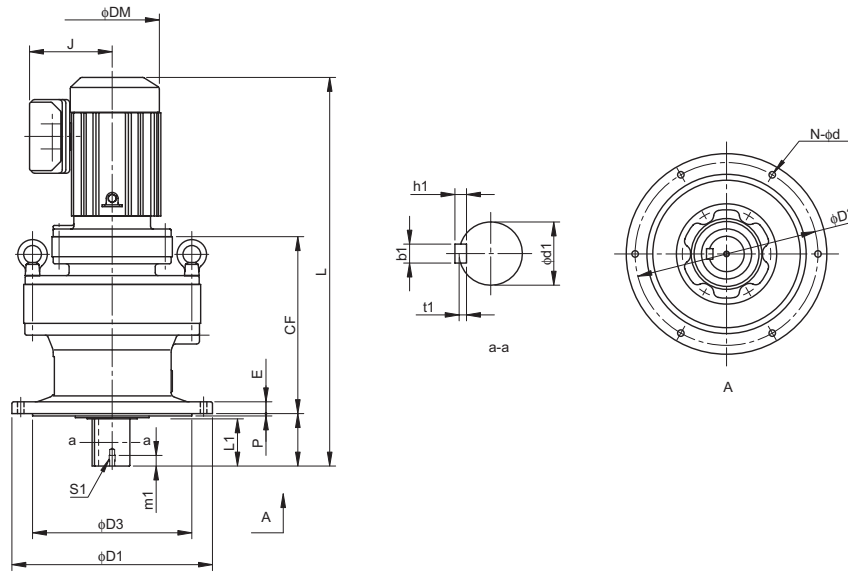

GEARMOTORS
Dimension Tables
CVVM

Frame size <small>Note 5</small>	CF	D1	D2	D3	M	E	P	N	d	H	Output Shaft <small>Note 2, 3, 7</small>						
											d1	L1	b1	h1	t1	S1	m1
616□DA	285	340	310	270	89	20	4	6	11	-	60	80	18	11	7	M10	18
616□DB	299	340	310	270	89	20	4	6	11	-	60	80	18	11	7	M10	18
617□DA	324	400	360	316	94	22	5	8	14	-	70	84	20	12	7.5	M12	24
617□DB	338	400	360	316	94	22	5	8	14	-	70	84	20	12	7.5	M12	24
618□DA	364	430	390	345	110	22	5	8	18	-	80	100	22	14	9	M12	24

Model <small>Note 5, 6</small>	Motor		Standard				With Brake			
	kW	P	L	J	DM	W(kg)	L	J	DM	W(kg)
CVVM02 -616□DA - (B) - Ratio	0.2	4	554	130	124	84	581	130	124	86
CVVM03 -616□DA - (B) - Ratio	0.25	4	554	130	124	84	581	130	124	86
CVVM05 -616□DA - (B) - Ratio	0.4	4	570	130	124	85	601	130	124	87
CVVM08 -616□DA - (B) - Ratio	0.55	4	611	140	148	89	653	140	148	92
CVVM1 -616□DA - (B) - Ratio	0.75	4	611	140	148	89	653	140	148	92
CVVM1H -616□DA - (B) - Ratio	1.1	4	643	145	160	93	705	145	160	98
CVVM2 -616□DA - (B) - Ratio	1.5	4	643	145	160	93	705	145	160	98
CVVM08 -616□DB - (B) - Ratio	0.55	4	625	140	148	91	667	140	148	94
CVVM1 -616□DB - (B) - Ratio	0.75	4	625	140	148	91	667	140	148	94
CVVM1H -616□DB - (B) - Ratio	1.1	4	658	145	160	95	719	145	160	100
CVVM2 -616□DB - (B) - Ratio	1.5	4	658	145	160	95	719	145	160	100
CVVM3 -616□DB - (B) - Ratio	2.2	4	678	152	173	99	740	152	173	105
CVVM02 -617□DA - (B) - Ratio	0.2	4	598	130	124	120	626	130	124	122
CVVM03 -617□DA - (B) - Ratio	0.25	4	598	130	124	120	626	130	124	122
CVVM05 -617□DA - (B) - Ratio	0.4	4	614	130	124	121	646	130	124	123
CVVM08 -617□DA - (B) - Ratio	0.55	4	655	140	148	125	698	140	148	128
CVVM1 -617□DA - (B) - Ratio	0.75	4	655	140	148	125	698	140	148	128
CVVM1H -617□DA - (B) - Ratio	1.1	4	688	145	160	129	750	145	160	134
CVVM2 -617□DA - (B) - Ratio	1.5	4	688	145	160	129	750	145	160	134
CVVM08 -617□DB - (B) - Ratio	0.55	4	669	140	148	122	712	140	148	129
CVVM1 -617□DB - (B) - Ratio	0.75	4	669	140	148	122	712	140	148	129
CVVM1H -617□DB - (B) - Ratio	1.1	4	702	145	160	131	764	145	160	136
CVVM2 -617□DB - (B) - Ratio	1.5	4	702	145	160	131	764	145	160	136
CVVM3 -617□DB - (B) - Ratio	2.2	4	722	152	173	135	785	152	173	141
CVVM05 -618□DA - (B) - Ratio	0.4	4	670	130	124	154	702	130	124	156
CVVM08 -618□DA - (B) - Ratio	0.55	4	711	140	148	158	754	140	148	161
CVVM1 -618□DA - (B) - Ratio	0.75	4	711	140	148	158	754	140	148	161
CVVM1H -618□DA - (B) - Ratio	1.1	4	744	145	160	162	806	145	160	167
CVVM2 -618□DA - (B) - Ratio	1.5	4	744	145	160	162	806	145	160	167
CVVM3 -618□DA - (B) - Ratio	2.2	4	764	152	173	166	827	152	173	172

Note: 5. □ indicates 0 or 5, expressing combination with reduction ratio. Refer to the Selection Table for details.
 6. "B" after the frame size indicates models equipped with brake.
 7. Dimension of shaft end: Refer to pages F-28 to F-29 for details.
 8. Dimensions in above drawings are subject to change without notice.

Dimension Tables Gearmotors (Vertical, Slow Speed Shaft Down, V-Flange Mount)

CVVM^{Note 1} - 616□DC to 618□DB

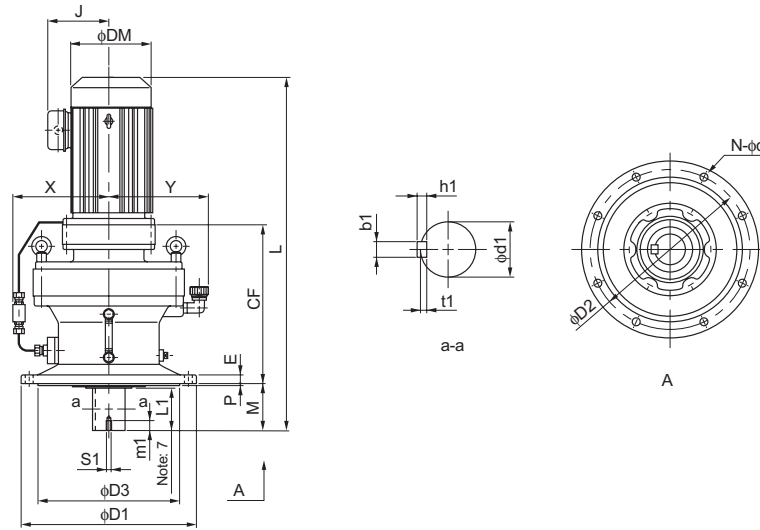

GEARMOTORS

Dimension Tables
CVVM

Frame size <small>Note 5</small>	CF	D1	D2	D3	M	E	P	N	d	X	Y	Output Shaft <small>Note 2, 3, 7</small>						
												d1	L1	b1	h1	t1	S1	m1
616□DC	300	340	310	270	89	20	4	6	11	196	200	60	80	18	11	7	M10	18
617□DC	342	400	360	316	94	22	5	8	14	218	225	70	84	20	12	7.5	M12	24
618□DB	386	430	390	345	110	22	5	8	18	233	240	80	100	22	14	9	M12	24

Model <small>Note 5, 6</small>	Motor		Standard				With Brake			
	kW	P	L	J	DM	W(kg)	L	J	DM	W(kg)
CVVM1H - 616□DC - (B) - Ratio	1.1	4	659	145	160	103	721	145	160	108
CVVM2 - 616□DC - (B) - Ratio	1.5	4	659	145	160	103	721	145	160	108
CVVM3 - 616□DC - (B) - Ratio	2.2	4	679	152	173	107	742	152	173	114
CVVM4 - 616□DC - (B) - Ratio	3.0	4	702	168	212	117	774	168	212	127
CVVM5 - 616□DC - (B) - Ratio	3.7	4	702	168	212	117	774	168	212	127
CVVM8 - 616□DC - (B) - Ratio	5.5	4	746	168	212	127	818	168	212	131
CVVM1H - 617□DC - (B) - Ratio	1.1	4	706	145	160	138	768	145	160	143
CVVM2 - 617□DC - (B) - Ratio	1.5	4	706	145	160	138	768	145	160	143
CVVM3 - 617□DC - (B) - Ratio	2.2	4	726	152	173	142	789	152	173	152
CVVM4 - 617□DC - (B) - Ratio	3.0	4	749	168	212	152	821	168	212	165
CVVM5 - 617□DC - (B) - Ratio	3.7	4	749	168	212	152	821	168	212	165
CVVM8 - 617□DC - (B) - Ratio	5.5	4	793	168	212	162	865	168	212	172
CVVM1H - 618□DB - (B) - Ratio	1.1	4	766	145	160	179	828	145	160	184
CVVM2 - 618□DB - (B) - Ratio	1.5	4	766	145	160	179	828	145	160	184
CVVM3 - 618□DB - (B) - Ratio	2.2	4	786	152	173	183	849	152	173	190
CVVM4 - 618□DB - (B) - Ratio	3.0	4	809	168	212	193	881	168	212	203
CVVM5 - 618□DB - (B) - Ratio	3.7	4	809	168	212	193	881	168	212	203
CVVM8 - 618□DB - (B) - Ratio	5.5	4	853	168	212	200	925	168	212	210
CVVM10 - 618□DB - (B) - Ratio	7.5	4	876	213	251	215	971	213	251	231
CVVM15 - 618□DB - (B) - Ratio	11	4	936	213	251	229	1031	213	251	247

- Note: 1. □ indicates motor capacity.
 2. Dimension of shaft end diameter: Dimension tolerance conforms to JIS B 0401-1976 "h6."
 3. Dimension of shaft end key: Dimension tolerance conforms to JIS B 1301-1996 "Parallel Key."
 4. Pilot diameter (φD3): Dimension tolerance conforms to JIS B 0401-1976 "f8."

Dimension Tables Gearmotors (Vertical, Slow Speed Shaft Down, V-Flange Mount)

CVVM^{Note 1} - 619□DA to 619□DB

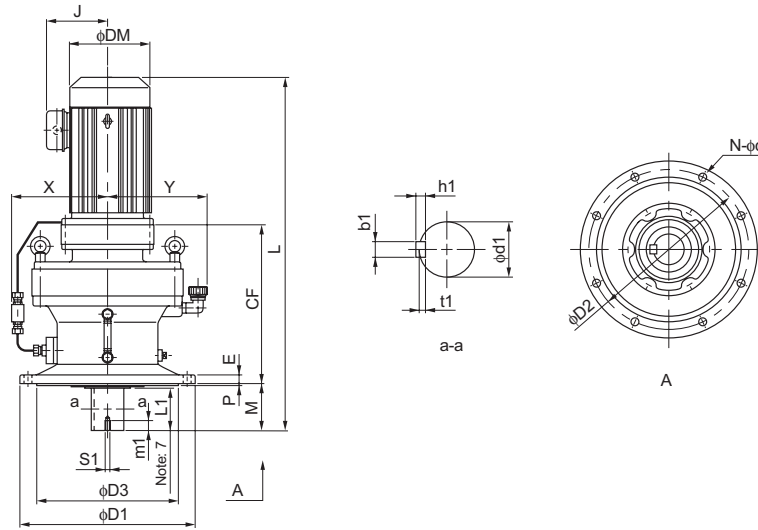

Dimension Tables
CVVM
GEARMOTORS

Frame size <small>Note 5</small>	CF	D1	D2	D3	M	E	P	N	d	X	Y	Output Shaft <small>Note 2, 3, 7</small>						
												d1	L1	b1	h1	t1	S1	m1
619□DA	411	490	450	400	145	30	6	12	18	255	270	95	125	25	14	9	M20	34
619□DB	427	490	450	400	145	30	6	12	18	255	270	95	125	25	14	9	M20	34

Model <small>Note 5, 6</small>	Motor		Standard				With Brake			
	kW	P	L	J	DM	W(kg)	L	J	DM	W(kg)
CVVM1 - 619□DA - (B) - Ratio	0.75	4	793	140	148	238	836	140	148	241
CVVM1H - 619□DA - (B) - Ratio	1.1	4	826	145	160	242	888	145	160	247
CVVM2 - 619□DA - (B) - Ratio	1.5	4	826	145	160	242	888	145	160	247
CVVM3 - 619□DA - (B) - Ratio	2.2	4	846	152	173	246	909	152	173	253
CVVM4 - 619□DA - (B) - Ratio	3.0	4	869	168	212	256	941	168	212	266
CVVM5 - 619□DA - (B) - Ratio	3.7	4	869	168	212	256	941	168	212	266
CVVM8 - 619□DA - (B) - Ratio	5.5	4	913	168	212	263	985	168	212	273
CVVM2 - 619□DB - (B) - Ratio	1.5	4	842	145	160	249	904	145	160	254
CVVM3 - 619□DB - (B) - Ratio	2.2	4	862	152	173	253	925	152	173	260
CVVM4 - 619□DB - (B) - Ratio	3.0	4	885	168	212	263	957	168	212	273
CVVM5 - 619□DB - (B) - Ratio	3.7	4	885	168	212	263	957	168	212	273
CVVM8 - 619□DB - (B) - Ratio	5.5	4	929	168	212	270	1001	168	212	280
CVVM10 - 619□DB - (B) - Ratio	7.5	4	952	213	251	285	1047	213	251	303
CVVM15 - 619□DB - (B) - Ratio	11	4	1012	213	251	299	1107	213	251	317
CVVM20 - 619□DB - (B) - Ratio	15	4	1102	261	324	351	1207	261	324	385

Note: 5. □ indicates 0 or 5, expressing combination with reduction ratio. Refer to the Selection Table for details.
 6. "B" after the frame size indicates models equipped with brake.
 7. Dimension of shaft end: Refer to pages F-28 to F-29 for details.
 8. Dimensions in above drawings are subject to change without notice.

Dimension Tables Gearmotors (Vertical, Slow Speed Shaft Down, V-Flange Mount)

CVVM^{Note 1} - 6205DA to 6215DA

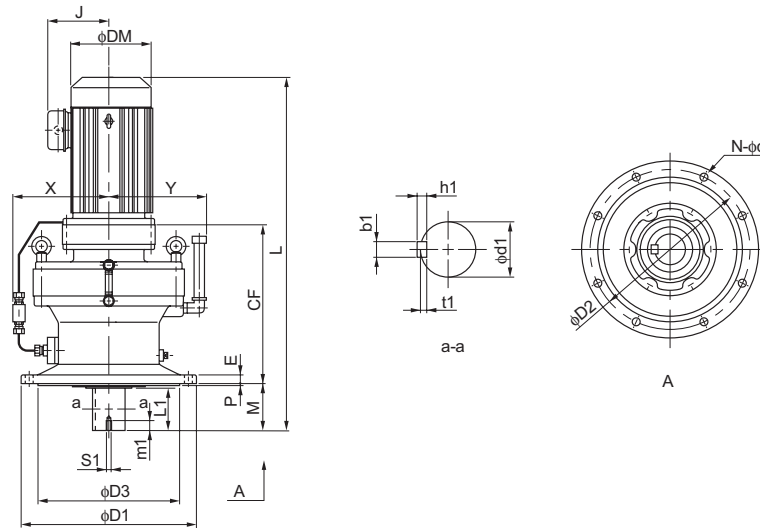

Frame size	CF	D1	D2	D3	M	E	P	N	d	X	Y	Output Shaft <small>Note 2, 3, 6</small>						
												d1	L1	b1	h1	t1	S1	m1
6205DA	393	455	405	355	204	30	5	8	22	341	287	100	165	28	16	10	M20	34
6205DB	420	455	405	355	204	30	5	8	22	341	287	100	165	28	16	10	M20	34
6215DA	447	490	440	390	203	35	7	8	24	348	306	110	165	28	16	10	M20	34

Model	Note 5	Motor		Standard				With Brake			
		kW	P	L	J	DM	W(kg)	L	J	DM	W(kg)
CVVM1	-6205DA - (B) - Ratio	0.75	4	834	140	148	254	877	140	148	257
CVVM2	-6205DA - (B) - Ratio	1.5	4	867	145	160	257	929	145	160	263
CVVM3	-6205DA - (B) - Ratio	2.2	4	887	152	173	262	949	152	173	269
CVVM4	-6205DA - (B) - Ratio	3.0	4	910	168	212	272	982	168	212	282
CVVM5	-6205DA - (B) - Ratio	3.7	4	910	168	212	272	982	168	212	282
CVVM8	-6205DA - (B) - Ratio	5.5	4	954	168	212	279	1026	168	212	289
CVVM3	-6205DB - (B) - Ratio	2.2	4	914	152	173	274	977	152	173	281
CVVM4	-6205DB - (B) - Ratio	3.0	4	937	168	212	284	1009	168	212	294
CVVM5	-6205DB - (B) - Ratio	3.7	4	937	168	212	284	1009	168	212	301
CVVM8	-6205DB - (B) - Ratio	5.5	4	981	168	212	291	1053	168	212	324
CVVM10	-6205DB - (B) - Ratio	7.5	4	1004	213	251	306	1099	213	251	347
CVVM15	-6205DB - (B) - Ratio	11	4	1064	213	251	320	1159	213	251	361
CVVM20	-6205DB - (B) - Ratio	15	4	1154	259	324	372	1249	259	324	429
CVVM2	-6215DA - (B) - Ratio	1.5	4	920	145	160	331	982	145	160	336
CVVM3	-6215DA - (B) - Ratio	2.2	4	940	152	173	334	1003	152	173	341
CVVM4	-6215DA - (B) - Ratio	3.0	4	963	168	212	344	1035	168	212	354
CVVM5	-6215DA - (B) - Ratio	3.7	4	963	168	212	344	1035	168	212	354
CVVM8	-6215DA - (B) - Ratio	5.5	4	1007	168	212	351	1079	168	212	361
CVVM10	-6215DA - (B) - Ratio	7.5	4	1030	213	251	366	1125	213	251	384
CVVM15	-6215DA - (B) - Ratio	11	4	1090	213	251	380	1185	213	251	398
CVVM20	-6215DA - (B) - Ratio	15	4	1180	161	324	432	1285	161	324	466

- Note: 1. \square indicates motor capacity.
 2. Dimension of shaft end diameter: Dimension tolerance conforms to JIS B 0401-1976 "h6."
 3. Dimension of shaft end key: Dimension tolerance conforms to JIS B 1301-1996 "Parallel Key."
 4. Pilot diameter ($\phi D3$): Dimension tolerance conforms to JIS B 0401-1976 "f8."

Dimension Tables Gearmotors (Vertical, Slow Speed Shaft Down, V-Flange Mount)

CVVM^{Note 1} - 6215DB to 6225DB

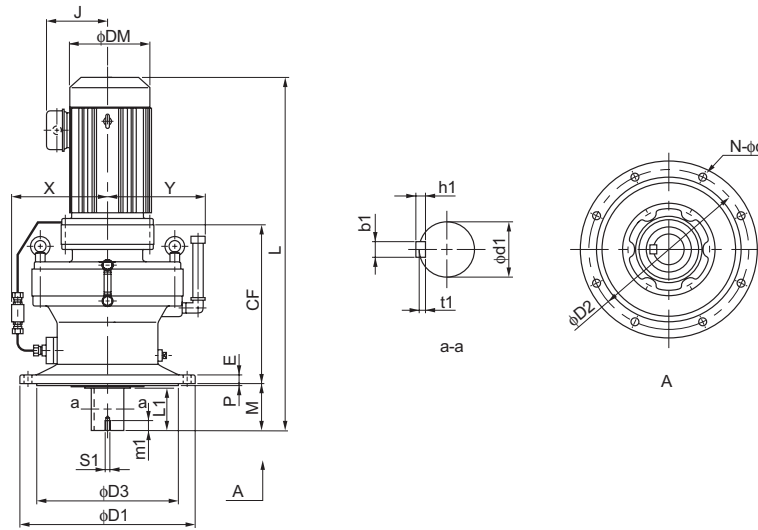

Dimension Tables
CVVM
GEARMOTORS

Frame size	CF	D1	D2	D3	M	E	P	N	d	X	Y	Output Shaft ^{Note 2, 3, 6}						
												d1	L1	b1	h1	t1	S1	m1
6215DB	472	490	440	390	203	35	7	8	24	348	306	110	165	28	16	10	M20	34
6225DA	482	535	475	415	210	35	10	8	27	352	326	120	165	32	18	11	M20	34
6225DB	525	535	475	415	210	35	10	8	27	352	326	120	165	32	18	11	M20	34

Model	Note 5	Motor		Standard				With Brake			
		kW	P	L	J	DM	W(kg)	L	J	DM	W(kg)
CVVM5	-6215DB - (B) - Ratio	3.7	4	993	168	212	377	1065	168	212	387
CVVM8	-6215DB - (B) - Ratio	5.5	4	1037	168	212	384	1109	168	212	400
CVVM10	-6215DB - (B) - Ratio	7.5	4	1060	213	251	400	1155	213	251	417
CVVM15	-6215DB - (B) - Ratio	11	4	1120	213	251	414	1215	213	251	431
CVVM20	-6215DB - (B) - Ratio	15	4	1205	261	324	467	1310	261	324	500
CVVM25	-6215DB - (B) - Ratio	18.5	4	1300	340	394	543	1465	340	394	587
CVVM30	-6215DB - (B) - Ratio	22	4	1300	340	394	543	1465	340	394	587
CVVM2	-6225DA - (B) - Ratio	1.5	4	962	145	160	420	1024	145	160	425
CVVM3	-6225DA - (B) - Ratio	2.2	4	982	152	173	423	1045	152	173	430
CVVM4	-6225DA - (B) - Ratio	3.0	4	1005	168	212	433	1077	168	212	443
CVVM5	-6225DA - (B) - Ratio	3.7	4	1005	168	212	433	1077	168	212	443
CVVM8	-6225DA - (B) - Ratio	5.5	4	1049	168	212	440	1121	168	212	450
CVVM10	-6225DA - (B) - Ratio	7.5	4	1072	213	251	455	1167	213	251	473
CVVM15	-6225DA - (B) - Ratio	11	4	1132	213	251	469	1227	213	251	486
CVVM20	-6225DA - (B) - Ratio	15	4	1222	261	324	521	1327	261	324	554
CVVM5	-6225DB - (B) - Ratio	3.7	4	1058	168	212	479	1130	168	212	490
CVVM8	-6225DB - (B) - Ratio	5.5	4	1102	168	212	486	1174	168	212	497
CVVM10	-6225DB - (B) - Ratio	7.5	4	1125	213	251	501	1220	213	251	519
CVVM15	-6225DB - (B) - Ratio	11	4	1185	213	251	515	1280	213	251	533
CVVM20	-6225DB - (B) - Ratio	15	4	1265	261	324	569	1370	261	324	603
CVVM25	-6225DB - (B) - Ratio	18.5	4	1360	340	394	661	1525	340	394	685
CVVM30	-6225DB - (B) - Ratio	22	4	1360	340	394	661	1525	340	394	685
CVVM40	-6225DB - (B) - Ratio	30	4	1360	340	394	678	1525	340	394	721

Note: 5. "B" after the frame size indicates models equipped with brake.
 6. Dimension of shaft end: Refer to pages F-28 to F-29 for details.
 7. Dimensions in above drawings are subject to change without notice.

Dimension Tables Gearmotors (Vertical, Slow Speed Shaft Down, V-Flange Mount)

CVVM^{Note 1} - 6235DA to 6245DB

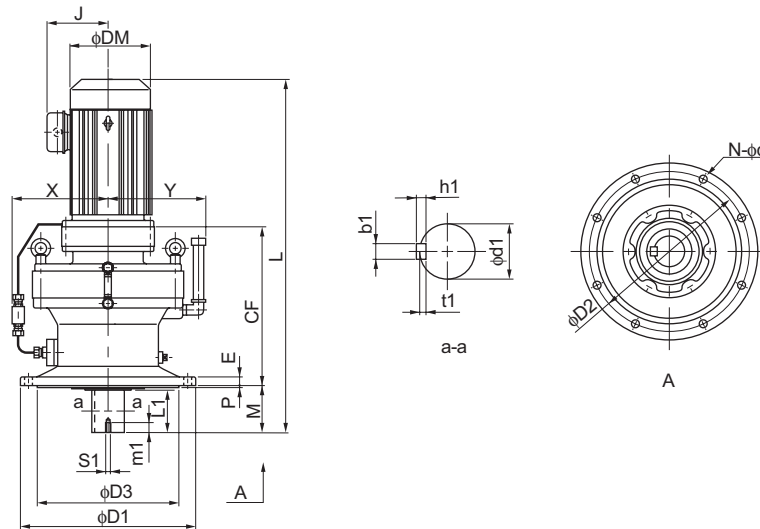

GEARMOTORS
Dimension Tables
CVVM

Frame size	CF	D1	D2	D3	M	E	P	N	d	X	Y	Output Shaft Note 2, 3, 6						
												d1	L1	b1	h1	t1	S1	m1
6235DA	529	570	510	450	250	40	10	8	27	359	344	130	200	32	18	11	M24	41
6235DB	551	570	510	450	250	40	10	8	27	359	344	130	200	32	18	11	M24	41
6245DA	566	635	560	485	250	40	10	8	33	370	371	140	200	36	20	12	M24	41
6245DB	587	635	560	485	250	40	10	8	33	370	371	140	200	36	20	12	M24	41

Model	Motor Note 5	Standard				With Brake			
		kW	P	L	J	DM	W(kg)	L	J
CVVM3 - 6235DA - (B) - Ratio	2.2 4	1069	152	173	523	1131	152	173	529
CVVM4 - 6235DA - (B) - Ratio	3.0 4	1091	168	212	532	1163	168	212	542
CVVM5 - 6235DA - (B) - Ratio	3.7 4	1091	168	212	532	1163	168	212	542
CVVM8 - 6235DA - (B) - Ratio	5.5 4	1135	168	212	539	1207	168	212	549
CVVM10 - 6235DA - (B) - Ratio	7.5 4	1163	213	251	555	1258	213	251	572
CVVM15 - 6235DA - (B) - Ratio	11 4	1223	213	251	569	1318	213	251	586
CVVM20 - 6235DA - (B) - Ratio	15 4	1309	261	324	622	1413	261	324	656
CVVM25 - 6235DA - (B) - Ratio	18.5 4	1403	340	394	698	1568	340	394	742
CVVM30 - 6235DA - (B) - Ratio	22 4	1403	340	394	698	1568	340	394	742
CVVM15 - 6235DB - (B) - Ratio	11 4	1245	213	251	601	1340	213	251	619
CVVM20 - 6235DB - (B) - Ratio	15 4	1330	261	324	663	1435	261	324	697
CVVM25 - 6235DB - (B) - Ratio	18.5 4	1425	340	394	730	1590	340	394	781
CVVM30 - 6235DB - (B) - Ratio	22 4	1425	340	394	730	1590	340	394	781
CVVM40 - 6235DB - (B) - Ratio	30 4	1425	340	394	744	1590	340	394	787
CVVM50 - 6235DB - (B) - Ratio	37 4	1540	340	394	792	1755	340	394	889
CVVM3 - 6245DA - (B) - Ratio	2.2 4	1106	152	173	617	1169	152	173	623
CVVM4 - 6245DA - (B) - Ratio	3.0 4	1129	168	212	626	1201	168	212	636
CVVM5 - 6245DA - (B) - Ratio	3.7 4	1129	168	212	626	1201	168	212	636
CVVM8 - 6245DA - (B) - Ratio	5.5 4	1173	168	212	633	1245	168	212	643
CVVM10 - 6245DA - (B) - Ratio	7.5 4	1201	213	251	649	1296	213	251	666
CVVM15 - 6245DA - (B) - Ratio	11 4	1261	213	251	663	1356	213	251	680
CVVM20 - 6245DA - (B) - Ratio	15 4	1346	261	324	716	1451	261	324	750
CVVM25 - 6245DA - (B) - Ratio	18.5 4	1441	340	394	792	1606	340	394	845
CVVM30 - 6245DA - (B) - Ratio	22 4	1441	340	394	792	1606	340	394	845
CVVM15 - 6245DB - (B) - Ratio	11 4	1282	213	251	690	1377	213	251	708
CVVM20 - 6245DB - (B) - Ratio	15 4	1367	261	324	750	1472	261	324	779
CVVM25 - 6245DB - (B) - Ratio	18.5 4	1462	340	394	816	1627	340	394	867
CVVM30 - 6245DB - (B) - Ratio	22 4	1462	340	394	816	1627	340	394	867
CVVM40 - 6245DB - (B) - Ratio	30 4	1462	340	394	833	1627	340	394	876
CVVM50 - 6245DB - (B) - Ratio	37 4	1577	340	394	881	1792	340	394	978

- Note: 1. □ indicates motor capacity.
 2. Dimension of shaft end diameter: Dimension tolerance conforms to JIS B 0401-1976 "h6."
 3. Dimension of shaft end key: Dimension tolerance conforms to JIS B 1301-1996 "Parallel Key."
 4. Pilot diameter (φD3): Dimension tolerance conforms to JIS B 0401-1976 "f8."

Dimension Tables Gearmotors (Vertical, Slow Speed Shaft Down, V-Flange Mount)

CVVM^{Note 1} - 6255DA to 6275DA

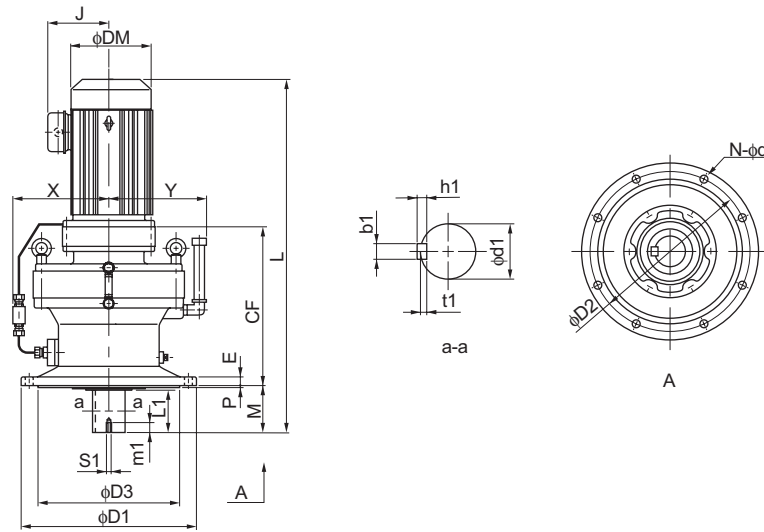

Dimension Tables
CVVM
GEARMOTORS

Frame size	CF	D1	D2	D3	M	E	P	N	d	X	Y	Output Shaft ^{Note 2, 3, 6}						
												d1	L1	b1	h1	t1	S1	m1
6255DA	661	685	610	535	295	45	10	8	33	395	399	160	240	40	22	13	M30	49
6255DB	684	685	610	535	295	45	10	8	33	395	399	160	240	40	22	13	M30	49
6265DA	728	750	660	570	360	50	10	8	39	427	431	170	300	40	22	13	M30	49
6275DA	994	1160	1020	900	355	60	10	8	39	610	613	180	320	45	25	15	M30	52

Model	Motor ^{Note 5}	Motor				Standard				With Brake			
		kW	P	L	J	DM	W(kg)	L	J	DM	W(kg)		
CVVM5	-6255DA - (B) - Ratio	3.7	4	1284	168	212	947	1356	168	212	957		
CVVM8	-6255DA - (B) - Ratio	5.5	4	1328	168	212	954	1400	168	212	964		
CVVM10	-6255DA - (B) - Ratio	7.5	4	1346	213	251	969	1441	213	251	984		
CVVM15	-6255DA - (B) - Ratio	11	4	1406	213	251	983	1501	213	251	998		
CVVM20	-6255DA - (B) - Ratio	15	4	1486	261	324	1041	1591	261	324	1077		
CVVM25	-6255DA - (B) - Ratio	18.5	4	1581	340	394	1110	1746	340	394	1161		
CVVM30	-6255DA - (B) - Ratio	22	4	1581	340	394	1110	1746	340	394	1161		
CVVM40	-6255DA - (B) - Ratio	30	4	1581	340	394	1129	1746	340	394	1172		
CVVM15	-6255DB - (B) - Ratio	11	4	1443	213	251	1059	1538	213	251	1074		
CVVM20	-6255DB - (B) - Ratio	15	4	1508	261	324	1109	1613	261	324	1143		
CVVM25	-6255DB - (B) - Ratio	18.5	4	1603	340	394	1185	1768	340	394	1236		
CVVM30	-6255DB - (B) - Ratio	22	4	1603	340	394	1185	1768	340	394	1236		
CVVM40	-6255DB - (B) - Ratio	30	4	1603	340	394	1200	1768	340	394	1243		
CVVM50	-6255DB - (B) - Ratio	37	4	1718	340	394	1238	1928	340	394	1335		
CVVM60	-6255DB - (B) - Ratio	45	4	1718	340	394	1238	1928	340	394	1335		
CVVM8	-6265DA - (B) - Ratio	5.5	4	1480	168	212	1296	1552	168	212	1306		
CVVM10	-6265DA - (B) - Ratio	7.5	4	1493	213	251	1309	1588	213	251	1329		
CVVM15	-6265DA - (B) - Ratio	11	4	1553	213	251	1326	1648	213	251	1341		
CVVM20	-6265DA - (B) - Ratio	15	4	1618	261	324	1376	1723	261	324	1412		
CVVM25	-6265DA - (B) - Ratio	18.5	4	1713	340	394	1455	1878	340	394	1500		
CVVM30	-6265DA - (B) - Ratio	22	4	1713	340	394	1455	1878	340	394	1500		
CVVM40	-6265DA - (B) - Ratio	30	4	1713	340	394	1470	1878	340	394	1513		
CVVM50	-6265DA - (B) - Ratio	37	4	1828	340	394	1505	2043	340	394	1598		
CVVM60	-6265DA - (B) - Ratio	45	4	1828	340	394	1505	2043	340	394	1598		
CVVM10	-6275DA - (B) - Ratio	7.5	4	1754	213	251	2694	1849	213	251	2714		
CVVM15	-6275DA - (B) - Ratio	11	4	1814	213	251	2708	1909	213	251	2723		
CVVM20	-6275DA - (B) - Ratio	15	4	1879	261	324	2761	1984	261	324	2797		
CVVM25	-6275DA - (B) - Ratio	18.5	4	1974	340	394	2840	2139	340	394	2885		
CVVM30	-6275DA - (B) - Ratio	22	4	1974	340	394	2840	2139	340	394	2885		
CVVM40	-6275DA - (B) - Ratio	30	4	1974	340	394	2855	2139	340	394	2898		
CVVM50	-6275DA - (B) - Ratio	37	4	2089	340	394	2890	2304	340	394	2983		
CVVM60	-6275DA - (B) - Ratio	45	4	2089	340	394	2890	2304	340	394	2983		

Note: 5. "B" after the frame size indicates models equipped with brake.
 6. Dimension of shaft end: Refer to pages F-28 to F-29 for details.
 7. Dimensions in above drawings are subject to change without notice.

Dimension Tables Gearmotors (Universal Direction, Foot-Mount)

CNHM^{Note 1} - 610H, 612H (Center Height Option)

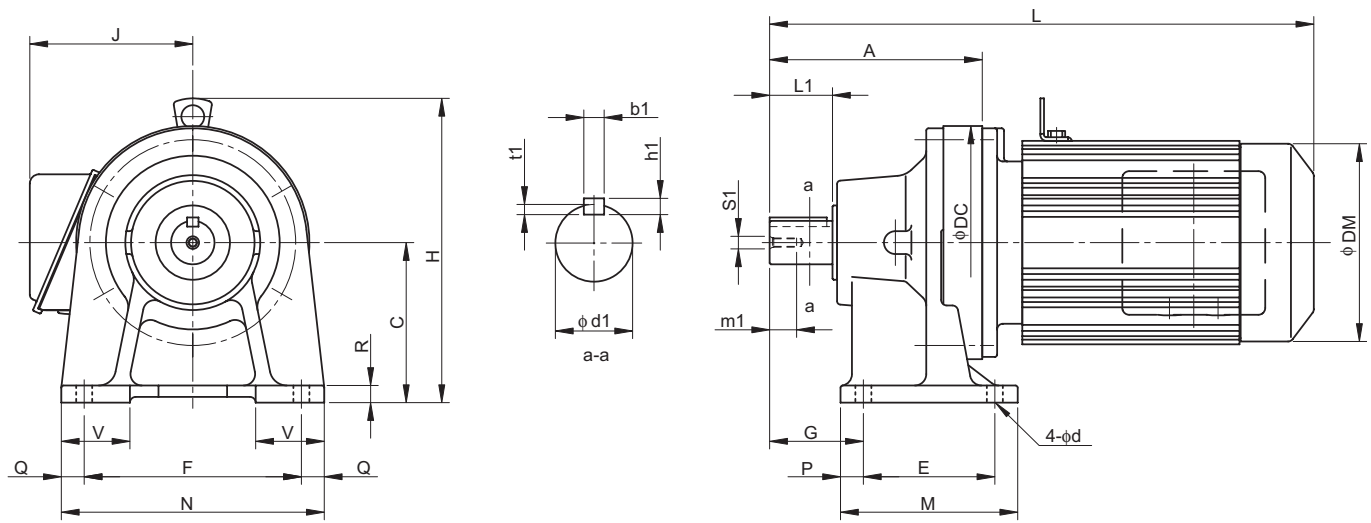

Frame size	A	C	DC	E	F	G	M	N	P	Q	R	V	d	Output Shaft <small>Note 2, 3, 5</small>						
														d1	L1	b1	h1	t1	S1	m1
610H	156	120	150	90	150	60	135	180	15	15	12	40	11	28	35	8	7	4	M8	20
612H	186	140	204	115	190	82	155	230	20	20	15	60	14	38	55	10	8	5	M8	20

Model	Note 4	Motor		Standard					With Brake					
		kW	P	L	H	J	DM	W(kg)	L	H	J	DM	W(kg)	
CNHM02	-610H	-(B) - Ratio	0.2	4	336	207	130	124	19	364	207	130	124	21
CNHM03	-610H	-(B) - Ratio	0.25	4	336	207	130	124	19	364	207	130	124	21
CNHM05	-610H	-(B) - Ratio	0.4	4	352	207	130	124	20	384	207	130	124	22
CNHM08	-610H	-(B) - Ratio	0.55	4	393	213	140	148	24	436	213	140	148	27
CNHM1	-610H	-(B) - Ratio	0.75	4	393	213	140	148	24	436	213	140	148	27
CNHM1H	-610H	-(B) - Ratio	1.1	4	426	220	145	160	28	488	220	145	160	33
CNHM2	-610H	-(B) - Ratio	1.5	4	426	220	145	160	28	488	220	145	160	33
CNHM3	-610H	-(B) - Ratio	2.2	4	446	226	152	173	32	509	226	152	173	38
CNHM05	-612H	-(B) - Ratio	0.4	4	387	257	130	124	31	419	257	130	124	33
CNHM08	-612H	-(B) - Ratio	0.55	4	423	233	140	148	33	466	233	140	148	36
CNHM1	-612H	-(B) - Ratio	0.75	4	423	233	140	148	33	466	233	140	148	36
CNHM1H	-612H	-(B) - Ratio	1.1	4	456	240	145	160	37	518	240	145	160	42
CNHM2	-612H	-(B) - Ratio	1.5	4	456	240	145	160	37	518	240	145	160	42
CNHM3	-612H	-(B) - Ratio	2.2	4	476	246	152	173	51	539	246	152	173	48
CNHM4	-612H	-(B) - Ratio	3.0	4	499	266	168	212	51	571	266	168	212	61
CNHM5	-612H	-(B) - Ratio	3.7	4	499	266	168	212	51	571	266	168	212	61
CNHM8	-612H	-(B) - Ratio	5.5	4	543	266	168	212	58	615	266	168	212	68

Note: 1. □ indicates motor capacity.
 2. Dimension of shaft end diameter: Dimension tolerance conforms to JIS B 0401-1976 "h6."
 3. Dimension of shaft end key: Dimension tolerance conforms to JIS B 1301-1996 "Parallel Key."

Dimension Tables Gearmotors (Horizontal Direction, Foot-Mount)

CHHM^{Note 1}- 614H, 616H (Center Height Option)

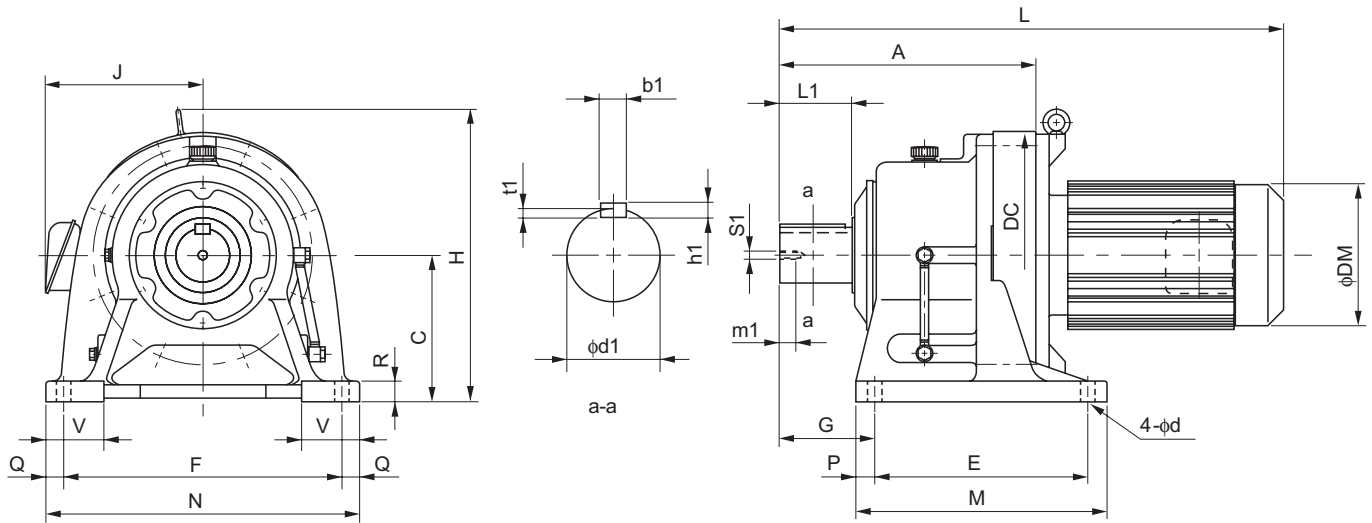

GEARMOTORS
Dimension Tables
Center Height Option

Frame size	A	C	DC	E	F	G	M	N	P	Q	R	V	d	Output Shaft <small>Note 2, 3, 5</small>						
														d1	L1	b1	h1	t1	S1	m1
614H	260	160	230	145	290	120	195	330	25	20	22	65	18	50	90	14	9	5.5	M10	18
616H	308	200	300	150	370	139	238	410	44	20	25	75	18	60	90	18	11	7	M10	18

Model	Note 4	Motor		Standard					With Brake				
		kW	P	L	H	J	DM	W(kg)	L	H	J	DM	W(kg)
CHHM1 - 614H	-(B) - Ratio	0.75	4	497	268	140	148	52	540	268	140	148	57
CHHM1H - 614H	-(B) - Ratio	1.1	4	530	268	145	160	58	592	268	145	160	63
CHHM2 - 614H	-(B) - Ratio	1.5	4	530	268	145	160	58	592	268	145	160	63
CHHM3 - 614H	-(B) - Ratio	2.2	4	550	274	152	173	61	613	274	152	173	68
CHHM4 - 614H	-(B) - Ratio	3.0	4	573	296	168	212	71	645	296	168	212	81
CHHM5 - 614H	-(B) - Ratio	3.7	4	573	296	168	212	71	645	296	168	212	81
CHHM8 - 614H	-(B) - Ratio	5.5	4	617	296	168	212	78	689	296	168	212	88
CHHM10 - 614H	-(B) - Ratio	7.5	4	640	323	213	251	93	735	323	213	251	111
CHHM15 - 614H	-(B) - Ratio	11	4	700	323	213	251	107	795	323	213	251	125
*CHHM20 - 614H	-(B) - Ratio	15	4	790	358	261	324	159	880	321	261	324	193
CHHM1H - 616H	-(B) - Ratio	1.1	4	583	310	145	160	99	645	310	145	160	104
CHHM2 - 616H	-(B) - Ratio	1.5	4	583	310	145	160	99	645	310	145	160	104
CHHM3 - 616H	-(B) - Ratio	2.2	4	598	310	152	173	102	661	310	152	173	108
CHHM4 - 616H	-(B) - Ratio	3.0	4	621	310	168	212	111	693	310	168	212	121
CHHM5 - 616H	-(B) - Ratio	3.7	4	621	310	168	212	111	693	310	168	212	121
CHHM8 - 616H	-(B) - Ratio	5.5	4	665	310	168	212	118	737	310	168	212	128
CHHM10 - 616H	-(B) - Ratio	7.5	4	693	333	213	251	134	788	333	213	251	151
CHHM15 - 616H	-(B) - Ratio	11	4	753	333	213	251	148	848	333	213	251	165
CHHM20 - 616H	-(B) - Ratio	15	4	838	368	261	324	201	928	368	261	324	235
CHHM25 - 616H	-(B) - Ratio	18.5	4	933	368	340	394	277	1098	368	340	394	328
CHHM30 - 616H	-(B) - Ratio	22	4	933	368	340	394	277	1098	368	340	394	328

*** indicates models with bottom level of the motor lower than the reducer base.

Note: 4. "B" after the frame size indicates models equipped with brake.
5. Dimension of shaft end: Refer to pages F-28 to F-29 for details.
6. Dimensions in above drawings are subject to change without notice.

M E M O

GEARMOTORS

Dimension
Tables

C

REDUCERS

CYCLO® SPEED REDUCERS

	Page
1. How to Select	
Standard Specifications	C-3
Model Selection	C-4
Selection of Load Factor	C-7
Nomenclature	C-9
2. Selection Tables	C-11
3. Dimension Tables	C-69

C CYCLO® SPEED REDUCER

1. How to Select

Standard Specifications of Reducer

		CYCLO® DRIVE 6000 Series	CYCLO® DRIVE 6000SK Series (With "SK" at the end of frame size)
Lubrication		Grease or oil lubricated models	Grease lubricated models
Speed reduction		Internal planetary gear mechanism with trochoidal curved tooth profile	Involute gear mechanism
Output rotation direction		Single reduction type	Reverse rotation direction
		Duble reduction type	Same rotation direction
		(*Note the difference with single reduction type of CYCLO® DRIVE 6000 Series.)	
		*In contrast to input rotation direction.	
Ambient Conditions	Installation location	Indoors (Minimal)	
	Ambient Temperature	-10°~40°C	
	Ambient Humidity	Under 85%	
	Elevation	Under 1,000 meters	
	Atmosphere	Well ventilated location, free of corrosive gases, explosive gases, vapors and dust.	
Method of Mounting Note 1		CHH Type : slow speed shaft in horizontal direction and with foot CHF Type : slow speed shaft in horizontal direction and with flange (not for 6000SK Series) CVV Type : slow speed shaft down in vertical direction and with V-flange *Models with "N" for the second nomenclature symbol (such as CNH Type) may be mounted in any direction.	
Method of coupling with driven machine		Coupling, gears, chain sprocket or belt.	
Painting		Type : Acrylic modified phthalic Colour : Equivalent to Mancel 6.5PB 3.6/8.2.	

Note: 1. Models for universal mounting (types with N for the second digit of nomenclature) can be manufactured for following frame sizes only. Other frame sizes require indication for mounting direction.

[Frame sizes for universal mounting direction] *□ of the frame size indicates 0, 5, or H.

606□, 607□, 608□, 609□, 610□, 611□, 612□,

606□DA, 607□DA, 608□DA, 609□DA, 610□DA, 612□DA, 612□DB

Model Selection

Select models referring to the following flowchart. Consult us if there is any question.
Step 1: Determination of Operating Condition

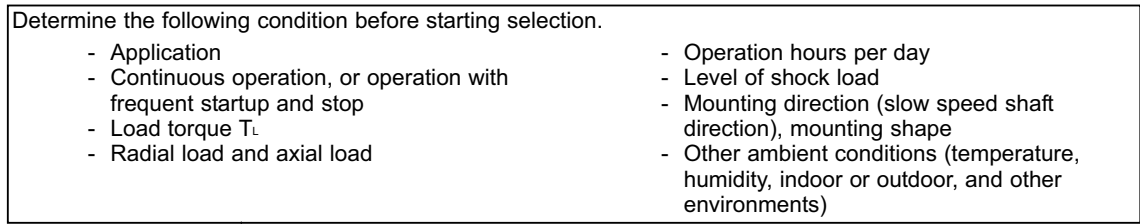

Step 2: Model Selection

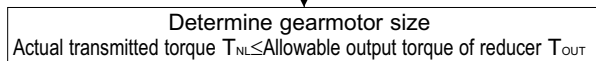
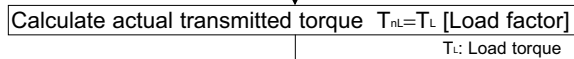
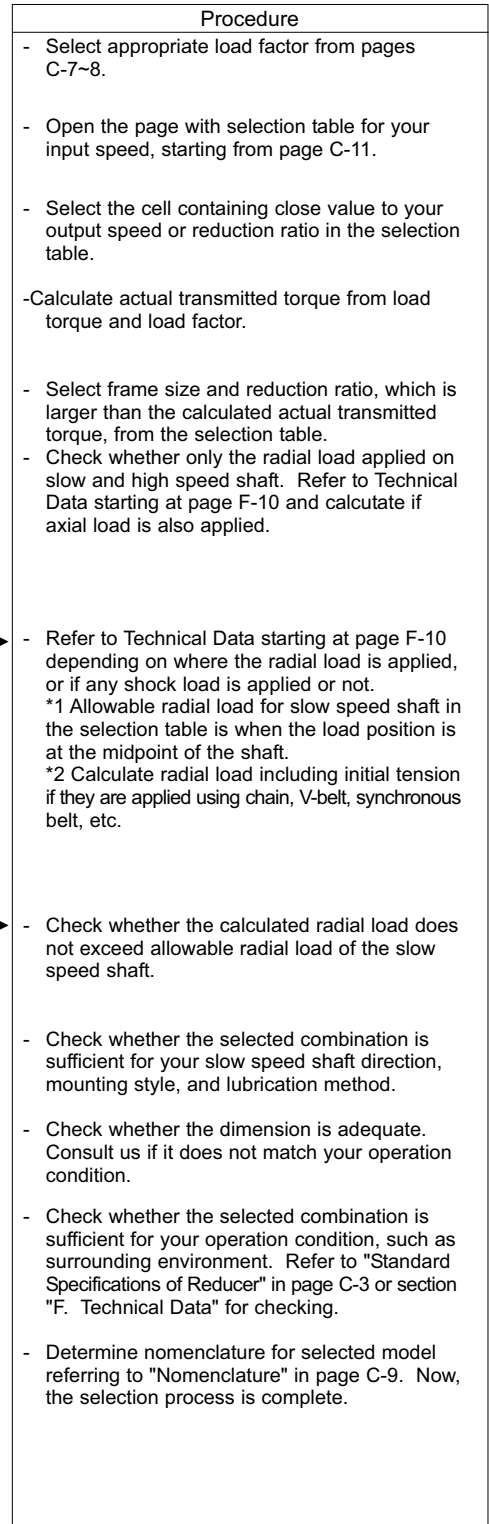
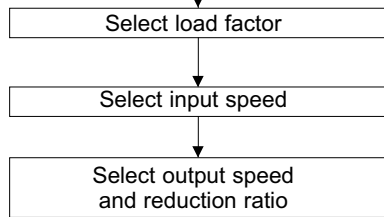

Step 3: Check

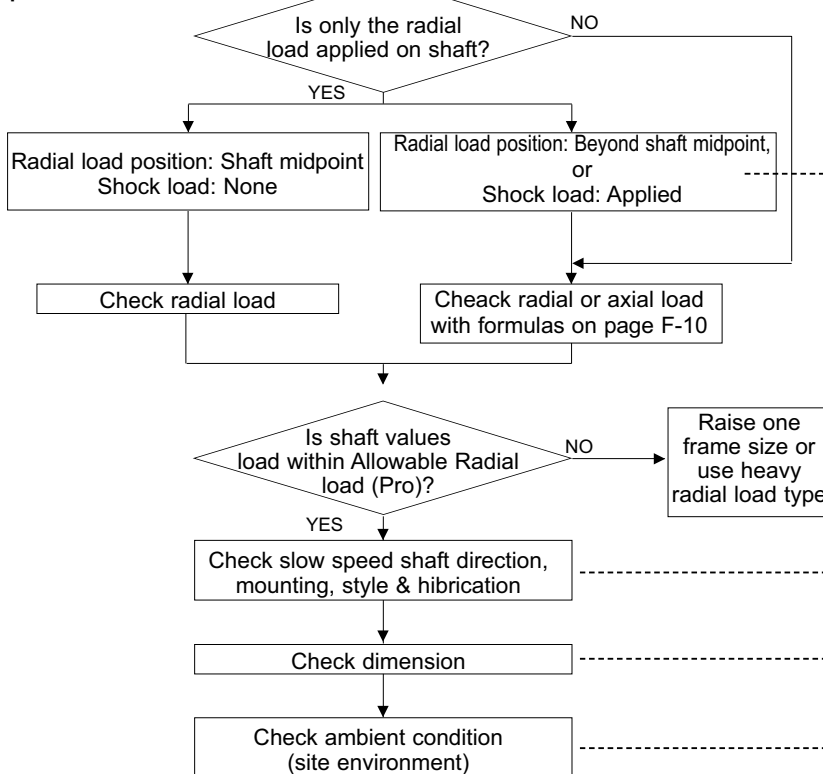

Step 4: Nomenclature Determination, Selection Complete

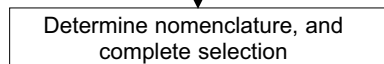

REDUCERS

How to Select

Model Selection

Description of Our Selection Table

This is a brief description of our tables on page C-11 and after.

Upper row: Output speed (r/min)
Lower row: Reduction ratio
* Note that "reduction ratio = nominal ratio" for models with "SK" at the end of frame size (6000 SK Series).
(Indicated reduction ratio is the same as actual reduction ratios for other models.)

Input speed (r/min)

Selection Tables 6000 Series Reducer

Single Reduction Ratio 6 ~ 119 Frame Size: 6060 ~ 6120

Frame Size	n ₂ [r/min] Ratio[Z]	n ₁ : Input Speed [r/min]													
		242	181	132	112	96.7	85.3	69.0	58.0	50.0	41.4	33.7	28.4	24.6	2
6060	P ₁ [kW]	0.200	0.200	0.200	0.200	0.200	0.200	0.183	0.110	0.110	0.110	0.089	-	-	
	T _{out} [N·m]	7.51	10.0	13.8	16.3	18.8	21.3	24.0	17.2	20.0	24.0	24.0	-	-	
	T _{out} [kgf·m]	0.766	1.02	1.41	1.66	1.92	2.17	2.45	1.75	2.04	2.45	2.45	-	-	
	Pro[N]	798	912	1180	1180	1180	1180	1180	1180	1180	1180	1180	-	-	
	Pro[kgf]	81.3	93	120	120	120	120	120	120	120	120	120	-	-	
6065	P ₁ [kW]	0.286	0.286	0.286	0.286	0.286	0.282	0.228	0.166	0.165	0.137	0.112	-	-	
	T _{out} [N·m]	10.7	14.3	19.7	23.3	26.9	30.0	30.0	25.9	30.0	30.0	30.0	-	-	
	T _{out} [kgf·m]	1.09	1.46	2.01	2.38	2.74	3.06	3.06	2.64	3.06	3.06	3.06	-	-	
	Pro[N]	793	904	1180	1180	1180	1180	1180	1180	1180	1180	1180	-	-	
	Pro[kgf]	80.8	92.2	120	120	120	120	120	120	120	120	120	-	-	
6070	P ₁ [kW]	0.347	0.347	0.347	0.347	0.347	0.347	0.310	0.230	0.226	0.205	0.167	0.100	0.100	
	T _{out} [N·m]	13.0	17.3	23.9	28.2	32.5	36.9	42.1	35.9	41.0	45.0	45.0	31.9	36.9	
	T _{out} [kgf·m]	1.33	1.76	2.44	2.87	3.31	3.76	4.29	3.66	4.18	4.59	4.59	3.25	3.76	
	Pro[N]	1380	1520	1690	1770	1770	1770	1770	1770	1770	1770	1770	1770	1770	
	Pro[kgf]	141	155	172	180	180	180	180	180	180	180	180	180	180	
6075	P ₁ [kW]	0.407	0.407	0.407	0.407	0.407	0.407	0.407	0.294	0.286	0.272	0.223	0.143	0.136	
	T _{out} [N·m]	15.3	20.4	28.0	33.1	38.2	43.3	53.5	46.0	52.0	59.6	60.0	45.7	50.1	
	T _{out} [kgf·m]	1.56	2.08	2.85	3.37	3.89	4.41	5.45	4.69	5.30	6.08	6.12	4.66	5.11	
	Pro[N]	1370	1510	1680	1770	1770	1770	1770	1770	1770	1770	1660	1750	1700	
	Pro[kgf]	140	154	171	180	180	180	180	180	180	180	169	178	173	
	P ₁ [kW]	0.592	0.592	0.592	0.592	0.592	0.592	0.478	0.340	0.340	0.340	0.250	0.192	0.185	0.



Frame size

First row: Allowable input capacity (kW)
Second row: Allowable output torque (N·m)
Third row: Allowable output torque (kgf·m)
Fourth row: Allowable radial load at slow speed shaft (N)
Fifth row: Allowable radial load at slow speed shaft (kgf)

REDUCERS
How to Select

Selection Example

Below is an example selection process following the model selection procedure in page C-4.

<ul style="list-style-type: none"> • Operation condition <ul style="list-style-type: none"> - Application: Chain conveyor - Operation hours per day: 24 hours/day - Operation pattern: Continuous operation - Load torque: 178N·m - Input speed: 1450 r/min - Output speed: 33.7 r/min 	<ul style="list-style-type: none"> - Connection with machine used: <ul style="list-style-type: none"> Output side: Chain sprocket Sprocket pitch circle radius: R=61mm Load position: Midpoint of shaft Initial tension=0 Input side: Coupling Level of shock load: None - Mounting direction (slow speed shaft direction), mounting style:
--	---



The model is selected based on above operation conditions in this example.

Operation condition, selection, and calculation results	Reference pages
<ul style="list-style-type: none"> • Select load factor Load condition for chain conveyor application → Uniform load (U) Load factor = 1.2 (U, 24 hours/day operation) 	Page C-7,8 Table C-2: Reducer Load Classification Table C-1: Reducer Load Factor
<ul style="list-style-type: none"> • Select input speed 1450 r/min 	Page C-15, 40-42, 48-57: CYCLO® SPEED REDUCERS Selection Tables
<ul style="list-style-type: none"> • Select output speed Power source frequency 50Hz, output speed 33.7r/min → 1450/33.7 = Reduction ratio 43 	Page C-40-42: CYCLO® SPEED REDUCERS Selection Tables
<ul style="list-style-type: none"> • Calculated actual transmitted torque $T_{nL}=178 \text{ (N·m)} \times 1.2=213.6 \text{ (N·m)}$ 	
<ul style="list-style-type: none"> • Determine reducer frame size $T_{nL} \leq T_{OUT} \rightarrow 213.6 \text{ (N·m)} \leq 292 \text{ (N·m)}$ Reducer frame size : 6105 	Page C-40: CYCLO® SPEED REDUCERS Selection Tables
<ul style="list-style-type: none"> • Check radial load (Output side) $Pr = TL/R \leq Pro/Cf$ $Pr = 199 \text{ (N·m)} / 0.061 \text{ (m)} = 3262 \text{ (N)} \leq 5400 \text{ (N)} / 1 = 5400 \text{ (N)} \rightarrow \text{OK}$ (Input side) No radial load because of coupling connection. 	Page F-10: Allowable Radial and Axial Load Page C-40: CYCLO® SPEED REDUCERS Selection Tables
<ul style="list-style-type: none"> • Check slow speed shaft direction, mounting style, lubrication method Slow speed shaft direction: Horizontal, Mounting style: Foot mount → Nomenclature: CNH (Grease lubrication method) 	Page C-9: Nomenclature
<ul style="list-style-type: none"> • Check dimension Check dimension using Dimension Tables. 	Page C-71: Dimension Tables
<ul style="list-style-type: none"> • Check surrounding condition Ambient temperature: 20°C → OK 	Page C-3: Standard Specifications of Gearmotor
<ul style="list-style-type: none"> • Determine nomenclature Determine nomenclature: CNH-6105-43 	Page C-9: Nomenclature
<p>The selection is complete.</p>	

Selection of Load Factor

CYCLO® SPEED REDUCER is designed for operation under uniform load for 10 hours/day.

Load factors below must be considered for operations exceeding 10 hours/day or load condition of your application. Select load factor by method (1) or (2) according to the load characteristics.

(1) Load Factor Selection by Load Classifications

[Load Factor] U: Uniform load M: Moderate shock H: Heavy shock

Table C-1 Reducer Load Factor

Daily Duty	~3 hours/day			~10 hours/day			~24 hours/day		
	U	M	H	U	M	H	U	M	H
Load Factor	0.80	1.00	1.35	1.00	1.20	1.50	1.50	1.35	1.60

Table C-2 Recommended Load Classifications

Type of APPLICATION	Type of LOAD	Type of APPLICATION	Type of LOAD	Type of APPLICATION	Type of LOAD	Type of APPLICATION	Type of LOAD
*Aerator		Elevators		slab conveyor	H	suction roll	U
Agitators		bucket - uniform load	U	small waste-conveyor-belt	U	washers & thickeners	M
pure liquids	U	bucket - heavy load	M	small waste-conveyor-chain	M	winders	U
liquids & solids	M	bucket - cont.	U	sorting table	M	*Printing Presses	
liquids-variable density	M	centrifugal discharge	U	tipple hoist conveyor	M	pullers	
Blowers		escalators	U	tipple hoist drive	M	barge haul	H
centrifugal	U	freight	M	transfer conveyors	M	Pumps	
lobe	M	gravity discharge	U	transfer rolls	M	centrifugal	U
vane	U	*man lifts		tray drive	M	proportioning	M
Brewing & Distilling		*passenger		trimmer feed	M	reciprocating single acting, 3 or more cylinders	M
bottling machinery	U	**Extruders(Plastics)		waste conveyor	M	double acting, 2 or more cylinders	M
brew kettles, cont. duty	U	blow molders	M	Machine Tools			
cookers-cont. duty	U	coating	U	bending roll	M	punch press-gear driven	H
mash tubs-cont. duty	U	film	U	*notching press-belt driven		plate planers	H
scale hopper, frequent starts	M	pipe	U	tapping machine	H	rotary-gear type	U
Can Filling Machines	U	pre-plasticizers	M	other machine tools		rotary-lobe, vane	U
*Cane Knives	M	rods	U	main drives	M	Rubber & Plastics Industries	
Car Dumpers	H	sheet	U	auxiliary drives	U	*crackers	H
Car Pullers	M	tubing	U	Metal Mills			
Clarifiers	U	Fans		draw bench carriage & main drive	M	laboratory equipment	M
Classifiers	M	centrifugal	U	forming machines	H	*mixing mills	H
Clay Working Machinery		*cooling towers		*pinch, dryer & scrubber rolls, reversing		*refiners	M
brick press	H	induced draft	U	slitters	M	*rubber calendars	M
briquette machine	H	*forced draft		table conveyors-non-reversing group drives	M	*rubber mill(2 on line)	M
clay working machinery	M	induced draft	M	individual drives	H	*rubber mill(3 on line)	U
pug mill	M	large(mine, etc.)	M	*table conveyors-reversing		*sheeter	M
Compressors		large(industrial)	M	wire drawing & flattening machine	M	*tire building machines	
centrifugal	U	light(small diameter)	U	wire winding machine	M	*tire & tube press openers	
lobe	M	Feeders		Mills, Rotary Type		*tubers & strainers	M
reciprocating, multi-cylinder	M	apron	M	*ball	M	*warming mills	M
reciprocating, single-cylinder	H	belt	M	*cement kilns	M	Sand Muller	M
Conveyors-Uniformly Loaded or Fed		disc	U	*dryers & coolers	M	Screens	
apron	U	reciprocating	H	*pebble	M	air washing	U
assembly	U	screw	M	*rod, plain & wedge bar	M	rotary-stone or gravel	M
belt	U	Food industry		tumbling barrels	H	traveling water intake	U
bucket	U	beet slicer	M	Mixers			
chain	U	cereal cooker	U	concrete mixers, cont.	M	concrete mixers, intermittent	M
flight	U	dough mixer	M	constant density	U	constant density	U
oven	U	meat grinders	M	variable density	M	thickeners	M
screw	U	Generators(not welding)	U	Oil Industry			
Conveyors-Heavy Duty Not Uniformly Fed		Hammer mills	H	chillers	M	slow or rapid mixers	M
apron	M	Hoists		*oil well pumping		sludge collectors	U
assembly	M	heavy duty	H	paraffin filter press	M	vacuum filters	M
belt	M	medium duty	M	rotary kilns	M	Slab Pushers	M
bucket	M	skip hoist	M	Paper Mills			
chain	M	Laundry Washers		agitators(mixers)	M	*Steering Gear	
flight	M	reversing	M	barker-auxiliaries-hydraulic	M	Stokers	U
*live roll	U	Laundry Tumblers	M	barker-mechanical	M	Sugar Industry	
oven	M	Line Shaft		barking drum	H	*cane knives	M
reciprocating	H	driving processing equipment	M	beater & pulper	M	*crushers	M
screw	M	light	U	bleacher	U	*mills	H
shaker	H	other line shafts	U	calendars	M	Textile Industry	
Cranes(Except for Dry Dock Cranes)		Lumber Industry		calendars-super	H	batchers	M
main hoists	M	barkers-hydraulic		converting machine, except cutters, platers	M	calendars	M
*bridge travel		mechanical	H	conveyors	U	cards	M
*trolley travel		burner conveyor	M	couch	M	dry cans	M
Crusher		chain saw & drag saw	H	cutters-platers	H	dryers	M
ore	H	chain transfer	H	cylinders	M	dyeing machinery	M
stone	H	craneway transfer	H	dryers	M	*knitting machines	
*sugar	M	de-barking drum	H	Paper Mills			
Dredges		edger feed	M	felt stretcher	M	looms	M
cable reels	M	gang feed	H	felt whipper	H	mangles	M
conveyors	M	green chain	M	jordans	H	nappers	M
cutter head drives	H	live rolls	H	log haul	H	pads	M
jig drives	H	log haul-locline	H	presses	U	*range drives	
maneuvering winches	M	log haul-well type	H	pulp machine reel	M	slashers	M
pumps	M	log turning device	H	stock chests	M	soapers	M
screen drive	H	main log conveyor	H	Remarks: * Refer to factory. ** To be selected on basis of 24hr. service only.			
stackers	M	off bearing rolls	M	Note: Table above contains reference value. Names and mechanical characteristics of the actual machine may differ from the table above.			
utility winches	M	planer feed chains	M	Sumitomo Drive Technologies			
*Dry Dock Cranes		planer floor chains	M	Reducers			
		planer tilting hoist	M	C-7			
		re-saw merry-go-round conveyor	M				
		roll cases	H				

REDUCERS
How to Select

Selection of Load Factor

(2) Load Factor Selection by Start - Stop Frequency

Select load factor according to the frequency of start - stop and operation hours.

Also, check the thermal load of your motor at this time (Refer to your motor manual).

Table C-3 Start - Stop Frequency and Reducer Load Factor

Number of start-stop (times/hour)	~3 hours/day			~10 hours/day			~24 hours/day		
	I	II	III	I	II	III	I	II	III
≤10	0.80	1.00	1.20	1.00	1.10	1.35	1.20	1.25	1.50
≤200	0.85	1.10	1.30	1.10	1.30	1.50	1.25	1.50	1.65
≤500	0.90	1.20	1.40	1.15	1.45	1.60	1.30	1.60	1.75

The ratio of Moment of Inertia (The ratio of GD^2) =
$$\frac{\text{Moment of Inertia (GD}^2\text{) of load as seen from the motor shaft}}{\text{Moment of Inertia (GD}^2\text{) of motor}}$$

- Load Factor
- I : Allowable ratio of Moment of Inertia (GD^2) ≤ 0.3
 - II : Allowable ratio of Moment of Inertia (GD^2) ≤ 3
 - III: Allowable ratio of Moment of Inertia (GD^2) ≤ 10

- Note:
1. Include operation times by brake, clutch, etc. in the start - stop frequency.
 2. Consult us for applications with startup with torque or radial load applied. Other solutions may be necessary.

Nomenclature

Slow Speed Shaft Direction	
Horizontal, slow speed shaft level	H
Vertical, slow speed shaft down	V
Vertical, slow speed shaft up	W
Universal mounting	N

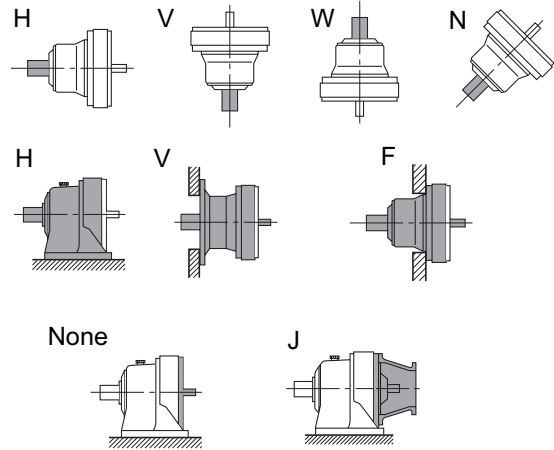

Mounting style	
Foot	H
V flange	V
Flange	F

Type of Input	
Gearmotor	M
With adaptor	JM

Special Specifications	
Standard specification	blank
Special specification	S

Shaft specification	
Metric JIS (Standard)	-
Inch size	Y
Metric DIN	G

Suffix			
Standard	-	HH Type Ceiling	H1
Light Heavy Radial	R1	Modification Left Wall	H2
High Cap. Brg. Ductile Casing	R2	Modification Right Wall	H3
Baseplate	BP	Torque Limiter	TL
Low Backlash	LB		

Frame size
(Refer to Selection
Tables starting from
page C-11.)

Nominal ratio

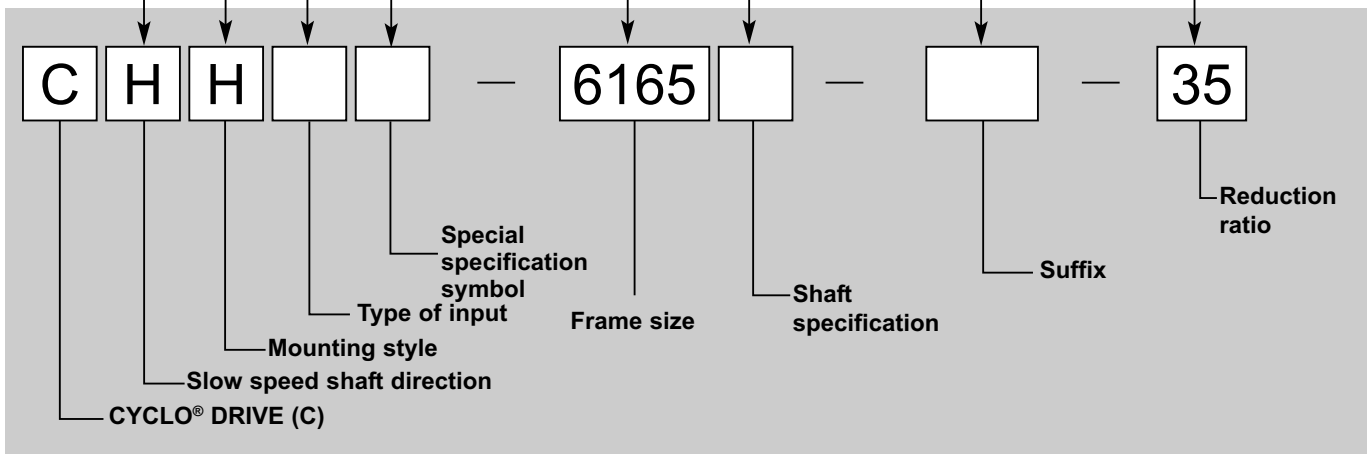

REDUCERS
How to Select

Nomenclature and Product Examples

Nomenclature Examples(Speed Reducer)

Example 1. CNH - 6115 - 29

C:	Model	- CYCLO® DRIVE
N:	Slow speed shaft direction	- Universal direction
H:	Mounting style	- Foot
6115:	Frame size	- 6115
29:	Reduction ratio	- 29

Example 2. CVV - 6195DA - 377

C:	Model	- CYCLO® DRIVE
V:	Slow speed shaft direction	- Vertical mounting
V:	Mounting style	- V flange
6195DA:	Frame size	- 6195DA
377:	Reduction ratio	- 377

REDUCERS

How to Select

Product and Nomenclature Symbol Examples (Speed Reducer)

Standard and various application products of CYCLO SPEED REDUCER are classified by their nomenclature symbol as below. Refer to specific catalogs or consult us for details on our application products.

CYCLO® SPEED REDUCERS

CHH
(CNH)

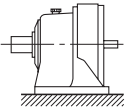

CHF
(CNF)

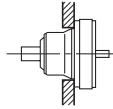

CHV
(CNV)

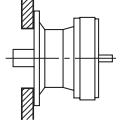

CVH
(CNH)

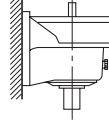

CVF
(CNF)

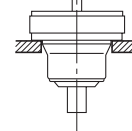

CVV
(CNV)

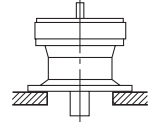

CWH
(CNH)

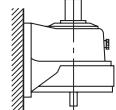

CFW
(CNF)

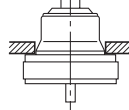

CWV
(CNV)

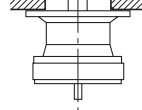

CHHJ

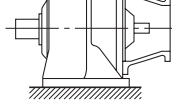

With Adaptor

CHFJ

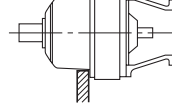

With Adaptor

CVVJ

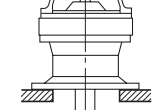

With Adaptor

CYCLO® SPEED REDUCERS Application Products

CHHX
(CNHX)

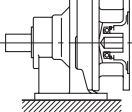

Input Side Hollow Shaft

CHF X
(CNFX)

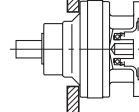

Input Side Hollow Shaft

CVV X
(CNVX)

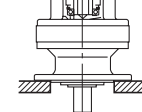

Input Side Hollow Shaft

C CYCLO® SPEED REDUCERS

2. Selection Tables

Selection Tables 6000SK Series Reducer

Nominal Reduction Ratio 2.5 ~ 10 Frame Size: 6070SK ~ 6115SK

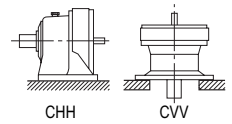

Input Speed	$n_1 = 50$ 580 r/min	n_1 : Input Speed [r/min]	T_{out} : Allowable output torque [N·m, kgf·m]
		n_2 : Output Speed [r/min]	Pro: Allowable output shaft radial load [N, kgf]
		P_i : Allowable input power [kW]	*Consult us for Pro of CNF and CHF type.

Selection Tables
Ratio 2.5 - 10
REDUCERS

Frame Size	n_1 [r/min]	50								580								Dim. Page
		n_2 [r/min]	20.0	16.7	12.5	10.0	8.33	6.25	5.00	232	193	145	116	96.7	72.5	58.0		
	Ratio[Z]	2.5	3	4	5	6	8	10	2.5	3	4	5	6	8	10			
6070SK	P_i [kW]	-	-	-	-	-	-	-	0.507	0.479	0.385	0.388	0.339	0.254	0.195	CHH C-70 CVW C-81		
	T_{out} [N·m]	29.4	30.5	24.1	44.8	46.6	45.8	47.4	19.8	22.5	24.1	30.3	31.8	31.7	30.5			
	T_{out} [kgf·m]	2.99	3.10	2.46	4.56	4.75	4.67	4.83	2.02	2.29	2.46	3.09	3.24	3.23	3.11			
	Pro[N]	1770	1770	1770	1770	1770	1770	1770	1490	1550	1730	1770	1770	1770	1770			
	Pro[kgf]	180	180	180	180	180	180	180	152	158	176	180	180	180	180			
	P_1 [kW]	-	-	-	-	-	-	-	0.634	0.599	0.482	0.485	0.424	0.317	0.244			
6075SK	T_{out} [N·m]	36.7	38.1	30.1	56.0	58.3	57.3	59.3	24.8	28.1	30.1	37.9	39.8	39.7	38.1	CHH C-70 CVW C-81		
	T_{out} [kgf·m]	3.74	3.88	3.07	5.70	5.94	5.84	6.04	2.53	2.87	3.07	3.87	4.05	4.04	3.88			
	Pro[N]	1770	1770	1770	1770	1770	1770	1770	1430	1490	1660	1770	1770	1770	1770			
	Pro[kgf]	180	180	180	180	180	180	180	146	152	169	180	180	180	180			
	P_i [kW]	-	-	-	-	-	-	-	0.784	0.822	0.895	0.748	0.632	0.495	0.379			
	T_{out} [N·m]	41.0	44.5	67.1	73.4	63.8	65.8	72.6	30.7	38.6	56.0	58.5	59.3	61.9	59.2			
6080SK	T_{out} [kgf·m]	4.17	4.54	6.84	7.49	6.50	6.70	7.40	3.12	3.93	5.71	5.97	6.04	6.31	6.04	CHH C-70 CVW C-81		
	Pro[N]	2560	2560	2560	2560	2560	2560	2560	1570	1620	1690	1860	1990	2200	2440			
	Pro[kgf]	261	261	261	261	261	261	261	160	165	172	190	203	224	249			
	P_i [kW]	-	-	-	-	-	-	-	0.981	1.03	1.12	0.879	0.790	0.618	0.473			
	T_{out} [N·m]	44.2	55.7	83.9	86.2	79.8	82.2	90.8	38.4	48.3	70.0	68.7	74.2	77.4	74.0			
	T_{out} [kgf·m]	4.51	5.67	8.56	8.79	8.14	8.38	9.25	3.91	4.92	7.13	7.00	7.56	7.89	7.55			
6090SK	Pro[N]	2560	2560	2560	2560	2560	2560	2560	1490	1530	1560	1770	1840	2060	2320	CHH C-70 CVW C-81		
	Pro[kgf]	261	261	261	261	261	261	261	152	156	159	180	188	210	236			
	P_i [kW]	-	-	-	-	-	-	-	1.15	1.11	1.12	1.06	0.883	0.691	0.645			
	T_{out} [N·m]	55.4	63.3	84.4	101	98.7	104	121	44.9	52.0	70.2	82.9	82.9	86.5	101			
	T_{out} [kgf·m]	5.65	6.46	8.61	10.3	10.1	10.6	12.3	4.58	5.30	7.16	8.45	8.45	8.81	10.3			
	Pro[N]	3340	3340	3340	3340	3340	3340	3340	2800	2900	3160	3340	3340	3340	3340			
6095SK	Pro[kgf]	340	340	340	340	340	340	340	285	296	322	340	340	340	340	CHH C-70 CVW C-81		
	P_i [kW]	-	-	-	-	-	-	-	1.30	1.25	1.25	1.25	1.05	0.814	0.814			
	T_{out} [N·m]	62.6	71.3	95.1	119	117	122	153	50.7	58.5	78.0	97.5	98.6	102	127			
	T_{out} [kgf·m]	6.38	7.27	9.70	12.1	12.0	12.5	15.6	5.17	5.97	7.95	9.94	10.0	10.4	13.0			
	Pro[N]	3340	3340	3340	3340	3340	3340	3340	2740	2840	3080	3220	3340	3340	3340			
	Pro[kgf]	340	340	340	340	340	340	340	279	289	314	328	340	340	340			
6100SK	P_i [kW]	-	-	-	-	-	-	-	1.35	1.32	1.29	1.28	1.07	0.848	0.891	CHH C-70 CVW C-81		
	T_{out} [N·m]	66.5	79.7	107	133	119	126	156	52.8	61.9	80.6	99.7	101	106	139			
	T_{out} [kgf·m]	6.78	8.12	11.0	13.6	12.2	12.8	15.9	5.38	6.31	8.22	10.2	10.3	10.8	14.2			
	Pro[N]	5400	5400	5400	5400	5400	5400	5400	2720	2810	3060	3200	3370	3710	3890			
	Pro[kgf]	550	550	550	550	550	550	550	277	286	312	326	344	378	397			
	P_i [kW]	-	-	-	-	-	-	-	1.50	1.55	1.52	1.50	1.26	0.996	0.990			
6105SK	T_{out} [N·m]	78.2	93.7	126	156	136	127	159	58.7	72.8	94.9	117	118	125	155	CHH C-70 CVW C-81		
	T_{out} [kgf·m]	7.97	9.55	12.9	15.9	13.8	13.0	16.3	5.98	7.42	9.67	11.9	12.1	12.7	15.8			
	Pro[N]	5400	5400	5400	5400	5400	5400	5400	2650	2700	2920	3030	3220	3500	3760			
	Pro[kgf]	550	550	550	550	550	550	550	270	275	298	309	328	357	383			
	P_i [kW]	-	-	-	-	-	-	-	2.52	2.52	2.50	2.30	2.05	1.58	1.32			
	T_{out} [N·m]	98.4	118	157	195	195	197	249	98.4	118	157	180	192	197	207			
6110SK	T_{out} [kgf·m]	10.0	12.0	16.0	19.9	19.9	20.1	25.4	10.0	12.0	16.0	18.3	19.6	20.1	21.1	CHH C-70 CVW C-81		
	Pro[N]	7610	7610	7610	7610	7610	7610	7610	3470	3650	3840	4060	4370	4920	5420			
	Pro[kgf]	776	776	776	776	776	776	776	354	372	391	414	445	502	552			
	P_i [kW]	-	-	-	-	-	-	-	3.15	3.15	3.13	2.88	2.56	1.97	1.65			
	T_{out} [N·m]	123	148	196	244	244	247	311	123	148	196	225	241	247	259			
	T_{out} [kgf·m]	12.5	15.0	20.0	24.9	24.9	25.2	31.7	12.5	15.0	20.0	22.9	24.5	25.2	26.4			
6115SK	Pro[N]	7610	7610	7610	7610	7610	7610	7610	3260	3400	3540	3740	4000	4570	5040	CHH C-70 CVW C-81		
	Pro[kgf]	776	776	776	776	776	776	776	332	347	361	381	408	466	514			
	Ratio[Z]	2.5	3	4	5	6	8	10	2.5	3	4	5	6	8	10			
	n_2 [r/min]	20.0	16.7	12.5	10.0	8.33	6.25	5.00	232	193	145	116	96.7	72.5	58.0			
	n_1 [r/min]	50								580								

Note: 1. Reduction ratio in the selection table is "nominal ratio." Refer to "6000 SK Series (Actual Reduction Ratio)" in page A-4 for actual reduction ratio.
 2. Allowable radial load Pro is the value at the midpoint of the output shaft. Refer to pages F-11~12 when radial load is off the midpoint of output shaft and for checking thrust load.
 3. Refer to pages F-15~16 for allowable radial load for input shaft.

Selection Tables 6000SK Series Reducer

Nominal Reduction Ratio 2.5 ~ 10 Frame Size: 6070SK ~ 6115SK

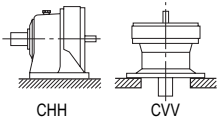

n_1 : Input Speed [r/min]	T_{out} : Allowable output torque [N·m, kgf·m]	Input Speed	$n_1 =$ 720 870 r/min
n_2 : Output Speed [r/min]	Pro: Allowable output shaft radial load [N, kgf]		
P_i : Allowable input power [kW]	*Consult us for Pro of CNF and CHF type.		

Frame Size	n_1 [r/min]	720								870								Dim. Page
		n_2 [r/min]	288	240	180	144	120	90.0	72.0	348	290	218	174	145	109	87.0		
		Ratio[Z]	2.5	3	4	5	6	8	10	2.5	3	4	5	6	8	10		
6070SK	P_i [kW]	0.614	0.581	0.478	0.473	0.414	0.310	0.238	0.723	0.686	0.578	0.563	0.492	0.369	0.284	CHH C-70 CVW C-81		
	T_{out} [N·m]	19.3	22.0	24.1	29.8	31.3	31.2	30.0	18.9	21.5	24.1	29.3	30.8	30.8	29.6			
	T_{out} [kgf·m]	1.97	2.24	2.46	3.04	3.19	3.18	3.06	1.92	2.19	2.46	2.99	3.14	3.14	3.02			
	Pro[N]	1370	1430	1590	1730	1770	1770	1770	1290	1330	1470	1600	1700	1770	1770			
	Pro[kgf]	140	146	162	176	180	180	180	131	136	150	163	173	180	180			
6075SK	P_i [kW]	0.767	0.726	0.598	0.591	0.517	0.387	0.298	0.904	0.857	0.723	0.703	0.615	0.461	0.355	CHH C-70 CVW C-81		
	T_{out} [N·m]	24.2	27.5	30.1	37.3	39.1	39.0	37.5	23.6	26.8	30.1	36.7	38.5	38.5	37.0			
	T_{out} [kgf·m]	2.46	2.80	3.07	3.80	3.98	3.98	3.82	2.40	2.73	3.07	3.74	3.92	3.92	3.77			
	Pro[N]	1320	1370	1520	1650	1750	1770	1770	1230	1290	1410	1530	1620	1770	1770			
	Pro[kgf]	135	140	155	168	178	180	180	125	131	144	156	165	180	180			
6080SK	P_i [kW]	0.935	0.981	1.03	0.912	0.771	0.604	0.463	1.09	1.14	1.17	1.08	0.917	0.719	0.551	CHH C-70 CVW C-81		
	T_{out} [N·m]	29.5	37.1	52.1	57.5	58.3	60.9	58.3	28.4	35.8	48.9	56.6	57.4	60.0	57.4			
	T_{out} [kgf·m]	3.00	3.78	5.31	5.86	5.94	6.20	5.94	2.90	3.65	4.98	5.76	5.85	6.11	5.85			
	Pro[N]	1450	1500	1570	1710	1810	2010	2250	1350	1390	1470	1580	1690	1860	2080			
	Pro[kgf]	148	153	160	174	185	205	229	138	142	150	161	172	190	212			
6085SK	P_i [kW]	1.17	1.23	1.29	1.07	0.964	0.755	0.578	1.36	1.43	1.47	1.27	1.15	0.899	0.688	CHH C-70 CVW C-81		
	T_{out} [N·m]	36.9	46.4	65.1	67.5	72.9	76.1	72.9	35.6	44.7	61.1	66.4	71.8	75.0	71.8			
	T_{out} [kgf·m]	3.76	4.73	6.64	6.88	7.43	7.76	7.43	3.62	4.56	6.23	6.77	7.32	7.64	7.32			
	Pro[N]	1380	1410	1450	1610	1690	1880	2120	1290	1310	1360	1490	1550	1740	1960			
	Pro[kgf]	141	144	148	164	172	192	216	131	134	139	152	158	177	200			
6090SK	P_i [kW]	1.38	1.33	1.33	1.27	1.07	0.834	0.778	1.61	1.56	1.56	1.49	1.25	0.980	0.915	CHH C-70 CVW C-81		
	T_{out} [N·m]	43.4	50.3	67.1	80.3	80.6	84.0	98.0	42.0	48.8	65.0	77.8	78.4	81.8	95.4			
	T_{out} [kgf·m]	4.42	5.13	6.84	8.18	8.22	8.57	10.0	4.28	4.97	6.63	7.93	7.99	8.34	9.73			
	Pro[N]	2580	2680	2920	3090	3260	3340	3340	2410	2500	2730	2870	3030	3340	3340			
	Pro[kgf]	263	273	298	315	332	340	340	246	255	278	293	309	340	340			
6095SK	P_i [kW]	1.56	1.50	1.50	1.50	1.27	0.983	0.983	1.82	1.76	1.76	1.76	1.49	1.16	1.16	CHH C-70 CVW C-81		
	T_{out} [N·m]	49.0	56.7	75.6	94.5	95.9	99.1	124	47.4	54.9	73.2	91.5	93.3	96.4	121			
	T_{out} [kgf·m]	4.99	5.78	7.70	9.63	9.77	10.1	12.6	4.83	5.60	7.46	9.33	9.51	9.83	12.3			
	Pro[N]	2520	2620	2840	2960	3120	3340	3340	2350	2440	2650	2750	2900	3200	3340			
	Pro[kgf]	257	267	290	302	318	340	340	240	249	270	280	296	326	340			
6100SK	P_i [kW]	1.68	1.64	1.60	1.58	1.33	1.05	1.11	1.91	1.98	1.93	1.91	1.61	1.27	1.34	CHH C-70 CVW C-81		
	T_{out} [N·m]	52.8	61.9	80.6	99.7	101	106	139	49.9	61.9	80.6	99.7	101	106	139			
	T_{out} [kgf·m]	5.38	6.31	8.22	10.2	10.3	10.8	14.2	5.09	6.31	8.22	10.2	10.3	10.8	14.2			
	Pro[N]	2480	2560	2800	2910	3080	3360	3540	2330	2370	2570	2680	2840	3090	3240			
	Pro[kgf]	253	261	285	297	314	343	361	238	242	262	273	289	315	330			
6105SK	P_i [kW]	1.86	1.93	1.88	1.86	1.56	1.24	1.23	2.25	2.33	2.27	2.25	1.89	1.49	1.48	CHH C-70 CVW C-81		
	T_{out} [N·m]	58.7	72.8	94.9	117	118	125	155	58.7	72.8	94.9	117	118	125	155			
	T_{out} [kgf·m]	5.98	7.42	9.67	11.9	12.1	12.7	15.8	5.98	7.42	9.67	11.9	12.1	12.7	15.8			
	Pro[N]	2420	2450	2650	2750	2910	3170	3390	2240	2260	2430	2510	2680	2880	3100			
	Pro[kgf]	247	250	270	280	297	323	346	228	230	248	256	273	294	316			
6110SK	P_i [kW]	3.12	3.12	3.11	2.75	2.47	1.96	1.61	3.66	3.76	3.75	3.20	2.89	2.37	1.92	CHH C-70 CVW C-81		
	T_{out} [N·m]	98.4	118	157	173	187	197	203	95.5	118	157	167	181	197	200			
	T_{out} [kgf·m]	10.0	12.0	16.0	17.7	19.0	20.1	20.7	9.74	12.0	16.0	17.0	18.4	20.1	20.4			
	Pro[N]	3170	3330	3490	3740	4000	4480	4960	2940	3070	3210	3470	3720	4120	4590			
	Pro[kgf]	323	339	356	381	408	457	506	300	313	327	354	379	420	468			
6115SK	P_i [kW]	3.91	3.90	3.88	3.44	3.09	2.45	2.02	4.58	4.70	4.69	4.00	3.61	2.96	2.40	CHH C-70 CVW C-81		
	T_{out} [N·m]	123	148	196	217	233	247	254	119	147	196	209	226	247	250			
	T_{out} [kgf·m]	12.5	15.0	20.0	22.1	23.8	25.2	25.9	12.2	15.0	20.0	21.3	23.0	25.2	25.5			
	Pro[N]	2950	3080	3200	3420	3650	4130	4600	2740	2830	2910	3180	3370	3770	4230			
	Pro[kgf]	301	314	326	349	372	421	469	279	288	297	324	344	384	431			
Frame Size	Ratio[Z]	2.5	3	4	5	6	8	10	2.5	3	4	5	6	8	10	Dim. Page		
	n_2 [r/min]	288	240	180	144	120	90.0	72.0	348	290	218	174	145	109	87.0			
	n_1 [r/min]	720								870								

REDUCERS
Selection Tables
Ratio 2.5 - 10

Note: 1. Reduction ratio in the selection table is "nominal ratio." Refer to "6000 SK Series (Actual Reduction Ratio)" in page A-4 for actual reduction ratio.
 2. Allowable radial load Pro is the value at the midpoint of the output shaft. Refer to pages F-11~12 when radial load is off the midpoint of output shaft and for checking thrust load.
 3. Refer to pages F-15~16 for allowable radial load for input shaft.

Selection Tables 6000SK Series Reducer

Nominal Reduction Ratio 2.5 ~ 10 Frame Size: 6070SK ~ 6115SK

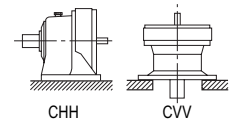

Input Speed	$n_1 = \begin{matrix} 980 \\ 1165 \end{matrix}$ r/min	n_1 : Input Speed [r/min]	T_{out} : Allowable output torque [N·m, kgf·m]
		n_2 : Output Speed [r/min]	Pro: Allowable output shaft radial load [N, kgf]
		P_1 : Allowable input power [kW]	*Consult us for Pro of CNF and CHF type.

Selection Tables
Ratio 2.5 - 10
REDUCERS

Frame Size	n_1 [r/min]	980							1165							Dim. Page
		n_2 [r/min]	392	327	245	196	163	123	98.0	466	388	291	233	194	146	
	Ratio[Z]	2.5	3	4	5	6	8	10	2.5	3	4	5	6	8	10	
6070SK	P_1 [kW]	0.801	0.760	0.649	0.627	0.549	0.411	0.317	0.927	0.882	0.763	0.734	0.642	0.482	0.371	CHH C-70 CVW C-81
	T_{out} [N·m]	18.5	21.1	24.0	29.0	30.5	30.5	29.3	18.1	20.6	23.8	28.6	30.0	30.0	28.9	
	T_{out} [kgf·m]	1.89	2.15	2.45	2.96	3.11	3.11	2.99	1.84	2.10	2.42	2.91	3.06	3.06	2.95	
	Pro[N]	1230	1280	1410	1530	1620	1770	1770	1150	1200	1310	1430	1520	1710	1770	
	Pro[kgf]	125	130	144	156	165	180	180	117	122	134	146	155	174	180	
6075SK	P_1 [kW]	1.00	0.950	0.811	0.784	0.686	0.514	0.396	1.16	1.10	0.953	0.918	0.803	0.603	0.464	CHH C-70 CVW C-81
	T_{out} [N·m]	23.2	26.4	30.0	36.3	38.1	38.1	36.6	22.6	25.7	29.7	35.7	37.5	37.6	36.1	
	T_{out} [kgf·m]	2.36	2.69	3.06	3.70	3.88	3.88	3.73	2.30	2.62	3.03	3.64	3.82	3.83	3.68	
	Pro[N]	1180	1230	1340	1460	1550	1750	1770	1100	1150	1260	1360	1450	1640	1770	
	Pro[kgf]	120	125	137	149	158	178	180	112	117	128	139	148	167	180	
6080SK	P_1 [kW]	1.20	1.26	1.27	1.19	0.997	0.802	0.615	1.38	1.42	1.42	1.34	1.12	0.939	0.720	CHH C-70 CVW C-81
	T_{out} [N·m]	27.9	35.1	47.0	55.3	55.4	59.4	56.9	27.0	33.3	44.4	52.2	52.3	58.5	56.1	
	T_{out} [kgf·m]	2.84	3.57	4.79	5.63	5.65	6.05	5.80	2.75	3.39	4.52	5.32	5.33	5.96	5.72	
	Pro[N]	1290	1330	1410	1500	1620	1780	1980	1220	1260	1330	1420	1520	1660	1850	
	Pro[kgf]	132	136	144	153	165	181	202	124	128	136	145	155	169	189	
6085SK	P_1 [kW]	1.51	1.58	1.59	1.40	1.25	1.00	0.768	1.73	1.78	1.78	1.57	1.40	1.17	0.900	CHH C-70 CVW C-81
	T_{out} [N·m]	34.8	43.8	58.8	64.9	69.3	74.2	71.1	33.7	41.6	55.5	61.3	65.4	73.2	70.1	
	T_{out} [kgf·m]	3.55	4.47	5.99	6.61	7.06	7.57	7.25	3.44	4.24	5.65	6.24	6.67	7.46	7.15	
	Pro[N]	1230	1260	1300	1420	1480	1650	1860	1150	1180	1240	1340	1400	1530	1740	
	Pro[kgf]	125	128	133	145	151	168	190	117	120	126	137	143	156	177	
6090SK	P_1 [kW]	1.77	1.72	1.72	1.64	1.39	1.08	1.01	2.03	1.97	1.97	1.89	1.60	1.25	1.17	CHH C-70 CVW C-81
	T_{out} [N·m]	41.0	47.7	63.6	76.1	77.0	80.3	93.7	39.5	46.1	61.5	73.6	74.8	78.1	91.1	
	T_{out} [kgf·m]	4.18	4.86	6.48	7.76	7.85	8.19	9.55	4.03	4.70	6.27	7.50	7.62	7.96	9.29	
	Pro[N]	2320	2390	2610	2760	2900	3210	3340	2180	2250	2450	2580	2720	3000	3270	
	Pro[kgf]	236	244	266	281	296	327	340	222	229	250	263	277	306	333	
6095SK	P_1 [kW]	2.00	1.93	1.93	1.93	1.65	1.28	1.28	2.29	2.22	2.22	2.22	1.90	1.48	1.48	CHH C-70 CVW C-81
	T_{out} [N·m]	46.3	53.7	71.6	89.6	91.6	94.7	118	44.6	51.9	69.2	86.5	88.9	92.1	115	
	T_{out} [kgf·m]	4.72	5.48	7.30	9.13	9.34	9.65	12.1	4.55	5.29	7.06	8.82	9.07	9.38	11.7	
	Pro[N]	2260	2330	2530	2630	2770	3050	3260	2120	2190	2370	2460	2590	2840	3050	
	Pro[kgf]	230	238	258	268	282	311	332	216	223	242	251	264	290	311	
6100SK	P_1 [kW]	2.16	2.23	2.18	2.15	1.81	1.43	1.51	2.56	2.65	2.59	2.56	2.15	1.70	1.71	CHH C-70 CVW C-81
	T_{out} [N·m]	49.9	61.9	80.6	99.7	101	106	139	49.9	61.9	80.6	99.7	101	106	133	
	T_{out} [kgf·m]	5.09	6.31	8.22	10.2	10.3	10.8	14.2	5.09	6.31	8.22	10.2	10.3	10.8	13.6	
	Pro[N]	2220	2260	2440	2530	2690	2920	3060	2070	2090	2260	2340	2480	2700	2870	
	Pro[kgf]	226	230	249	258	274	298	312	211	213	230	239	253	275	293	
6105SK	P_1 [kW]	2.53	2.62	2.56	2.53	2.13	1.68	1.67	3.01	3.12	3.05	3.01	2.53	2.00	1.90	CHH C-70 CVW C-81
	T_{out} [N·m]	58.7	72.8	94.9	117	118	125	155	58.7	72.8	94.9	117	118	125	148	
	T_{out} [kgf·m]	5.98	7.42	9.67	11.9	12.1	12.7	15.8	5.98	7.42	9.67	11.9	12.1	12.7	15.1	
	Pro[N]	2130	2140	2300	2370	2530	2730	2920	1970	1980	2120	2180	2320	2490	2740	
	Pro[kgf]	217	218	234	242	258	278	298	201	202	216	222	237	254	279	
6110SK	P_1 [kW]	3.97	4.07	4.12	3.50	3.18	2.67	2.14	4.45	4.56	4.62	3.95	3.62	3.13	2.51	CHH C-70 CVW C-81
	T_{out} [N·m]	91.8	113	153	162	176	197	198	86.7	107	144	154	169	195	195	
	T_{out} [kgf·m]	9.36	11.5	15.6	16.5	18.0	20.1	20.2	8.83	10.9	14.7	15.7	17.2	19.9	19.9	
	Pro[N]	2840	2950	3060	3340	3550	3900	4380	2680	2790	2890	3140	3340	3630	4070	
	Pro[kgf]	289	301	312	340	362	398	446	273	284	295	320	340	370	415	
6115SK	P_1 [kW]	4.96	5.08	5.15	4.37	3.97	3.34	2.68	5.57	5.70	5.78	4.94	4.53	3.91	3.14	CHH C-70 CVW C-81
	T_{out} [N·m]	115	141	191	202	221	247	248	108	133	180	192	212	244	244	
	T_{out} [kgf·m]	11.7	14.4	19.4	20.6	22.5	25.2	25.3	11.0	13.6	18.4	19.6	21.6	24.8	24.9	
	Pro[N]	2630	2710	2780	3040	3220	3560	4010	2480	2560	2620	2850	3010	3290	3720	
	Pro[kgf]	268	276	283	310	328	363	409	253	261	267	291	307	335	379	
Frame Size	Ratio[Z]	2.5	3	4	5	6	8	10	2.5	3	4	5	6	8	10	Dim. Page
	n_2 [r/min]	392	327	245	196	163	123	98.0	466	388	291	233	194	146	117	
	n_1 [r/min]	980							1165							

- Note: 1. Reduction ratio in the selection table is "nominal ratio." Refer to "6000 SK Series (Actual Reduction Ratio)" in page A-4 for actual reduction ratio.
 2. Allowable radial load Pro is the value at the midpoint of the output shaft. Refer to pages F-11~12 when radial load is off the midpoint of output shaft and for checking thrust load.
 3. Refer to pages F-15~16 for allowable radial load for input shaft.

Selection Tables 6000SK Series Reducer

Nominal Reduction Ratio 2.5 ~ 10 Frame Size: 6070SK ~ 6115SK

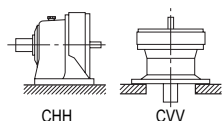

n_1 : Input Speed [r/min]	T_{out} : Allowable output torque [N·m, kgf·m]	Input Speed	$n_1 = \begin{matrix} 1450 \\ 1750 \end{matrix}$ r/min
n_2 : Output Speed [r/min]	Pro: Allowable output shaft radial load [N, kgf]		
P_i : Allowable input power [kW]	*Consult us for Pro of CNF and CHF type.		

Frame Size	n_1 [r/min]	1450								1750								Dim. Page
		n_2 [r/min]	580	483	363	290	242	181	145	700	583	438	350	292	219	175		
		Ratio[Z]	2.5	3	4	5	6	8	10	2.5	3	4	5	6	8	10		
6070SK	P_i [kW]	1.11	1.06	0.935	0.886	0.784	0.589	0.454	1.11	1.06	0.935	0.886	0.784	0.589	0.454	CHH C-70		
	T_{out} [N·m]	17.4	19.9	23.4	27.7	29.4	29.5	28.4	14.4	16.5	19.4	23.0	24.4	24.4	23.5			
	T_{out} [kgf·m]	1.77	2.03	2.39	2.83	3.00	3.01	2.89	1.47	1.68	1.98	2.34	2.49	2.49	2.40			
	Pro[N]	1070	1110	1210	1320	1390	1570	1730	1020	1060	1170	1280	1340	1510	1650			
	Pro[kgf]	109	113	123	135	142	160	176	104	108	119	130	137	154	168			
6075SK	P_i [kW]	1.39	1.32	1.17	1.11	0.980	0.736	0.567	1.39	1.32	1.17	1.11	0.980	0.736	0.567	CHH C-70		
	T_{out} [N·m]	21.7	24.9	29.3	34.7	36.8	36.9	35.5	18.0	20.6	24.3	28.7	30.5	30.5	29.4			
	T_{out} [kgf·m]	2.21	2.53	2.98	3.53	3.75	3.76	3.62	1.83	2.10	2.47	2.93	3.11	3.11	3.00			
	Pro[N]	1020	1060	1150	1260	1320	1500	1660	980	1020	1110	1220	1290	1450	1590			
	Pro[kgf]	104	108	117	128	135	153	169	100	104	113	124	131	148	162			
6080SK	P_i [kW]	1.65	1.65	1.65	1.55	1.30	1.10	0.880	1.65	1.65	1.65	1.55	1.30	1.10	0.880	CHH C-70		
	T_{out} [N·m]	25.8	30.9	41.2	48.5	48.6	54.8	55.1	21.3	25.6	34.2	40.2	40.3	45.4	45.6			
	T_{out} [kgf·m]	2.62	3.15	4.20	4.94	4.96	5.59	5.61	2.18	2.61	3.48	4.10	4.11	4.63	4.65			
	Pro[N]	1130	1170	1240	1320	1410	1530	1700	1090	1130	1210	1290	1380	1490	1650			
	Pro[kgf]	115	119	126	135	144	156	173	111	115	123	131	141	152	168			
6085SK	P_i [kW]	2.06	2.06	2.06	1.82	1.62	1.37	1.10	2.06	2.06	2.06	1.82	1.62	1.37	1.10	CHH C-70		
	T_{out} [N·m]	32.2	38.7	51.6	56.9	60.8	68.6	68.8	26.7	32.0	42.7	47.2	50.4	56.8	57.0			
	T_{out} [kgf·m]	3.28	3.94	5.26	5.80	6.20	6.99	7.02	2.72	3.27	4.35	4.81	5.14	5.79	5.81			
	Pro[N]	1060	1100	1150	1250	1300	1410	1590	1030	1070	1130	1230	1290	1390	1550			
	Pro[kgf]	108	112	117	127	133	144	162	105	109	115	125	131	142	158			
6090SK	P_i [kW]	2.40	2.34	2.34	2.24	1.91	1.50	1.40	2.40	2.34	2.34	2.24	1.91	1.50	1.40	CHH C-70		
	T_{out} [N·m]	37.5	43.9	58.6	70.1	71.7	75.1	87.6	31.1	36.4	48.5	58.1	59.4	62.2	72.6			
	T_{out} [kgf·m]	3.83	4.48	5.97	7.14	7.31	7.65	8.93	3.17	3.71	4.95	5.92	6.06	6.34	7.40			
	Pro[N]	2010	2080	2260	2380	2510	2760	3010	1930	2000	2190	2320	2420	2680	2910			
	Pro[kgf]	205	212	230	243	256	281	307	197	204	223	236	247	273	297			
6095SK	P_i [kW]	2.71	2.64	2.64	2.64	2.27	1.77	1.77	2.71	2.64	2.64	2.64	2.27	1.77	1.77	CHH C-70		
	T_{out} [N·m]	42.4	49.5	66.0	82.5	85.3	88.5	111	35.1	41.0	54.7	68.3	70.7	73.4	92			
	T_{out} [kgf·m]	4.32	5.04	6.72	8.41	8.70	9.02	11.3	3.58	4.18	5.57	6.96	7.21	7.48	9.3			
	Pro[N]	1960	2020	2190	2270	2380	2620	2800	1890	1960	2130	2220	2320	2560	2740			
	Pro[kgf]	200	206	223	231	243	267	285	193	200	217	226	237	261	279			
6100SK	P_i [kW]	3.19	3.30	3.22	3.15	2.67	2.12	1.98	3.19	3.30	3.22	3.15	2.67	2.12	1.98	CHH C-70		
	T_{out} [N·m]	49.9	61.9	80.6	98.6	100	106	124	41.3	51.3	66.8	81.7	83	88	103			
	T_{out} [kgf·m]	5.09	6.31	8.22	10.0	10.2	10.8	12.6	4.21	5.23	6.81	8.3	8.5	9.0	10.5			
	Pro[N]	1880	1900	2040	2120	2250	2420	2680	1820	1850	2010	2090	2220	2400	2640			
	Pro[kgf]	192	194	208	216	229	247	273	186	189	205	213	226	245	269			
6105SK	P_i [kW]	3.75	3.88	3.79	3.70	3.14	2.49	2.20	3.75	3.88	3.79	3.70	3.14	2.49	2.20	CHH C-70		
	T_{out} [N·m]	58.7	72.8	94.9	116	118	125	138	48.6	60.4	78.6	96	98	103	114			
	T_{out} [kgf·m]	5.98	7.42	9.67	11.8	12.0	12.7	14.0	4.95	6.15	8.01	9.8	9.9	10.5	11.6			
	Pro[N]	1800	1800	1900	1960	2090	2230	2550	1750	1770	1890	1960	2080	2240	2530			
	Pro[kgf]	183	183	194	200	213	227	260	178	180	193	200	212	228	258			
6110SK	P_i [kW]	5.15	5.28	5.35	4.61	4.22	3.70	3.06	5.15	5.28	5.35	4.61	4.22	3.70	3.06	CHH C-70		
	T_{out} [N·m]	80.6	99.1	134	144	158	185	191	66.8	82.1	111	120	131	153	159			
	T_{out} [kgf·m]	8.21	10.1	13.6	14.7	16.1	18.9	19.5	6.80	8.4	11.3	12.2	13.4	15.6	16.2			
	Pro[N]	2480	2590	2690	2900	3090	3350	3710	2410	2520	2640	2840	3030	3290	3640			
	Pro[kgf]	253	264	274	296	315	341	378	246	257	269	290	309	335	371			
6115SK	P_i [kW]	6.44	6.60	6.69	5.77	5.28	4.63	3.83	6.44	6.60	6.69	5.77	5.28	4.63	3.83	CHH C-70		
	T_{out} [N·m]	101	124	167	180	198	232	239	83	103	139	150	164	192	198			
	T_{out} [kgf·m]	10.3	12.6	17.1	18.4	20.2	23.6	24.4	8.5	10.5	14.1	15.2	16.7	19.6	20.2			
	Pro[N]	2310	2380	2430	2650	2800	3010	3360	2270	2340	2420	2630	2790	3010	3360			
	Pro[kgf]	235	243	248	270	285	307	343	231	239	247	268	284	307	342			
Frame Size	Ratio[Z]	2.5	3	4	5	6	8	10	2.5	3	4	5	6	8	10	Dim. Page		
	n_2 [r/min]	580	483	363	290	242	181	145	700	583	438	350	292	219	175			
	n_1 [r/min]	1450								1750								

REDUCERS
Selection Tables
Ratio 2.5 - 10

Note: 1. Reduction ratio in the selection table is "nominal ratio." Refer to "6000 SK Series (Actual Reduction Ratio)" in page A-4 for actual reduction ratio.
 2. Allowable radial load Pro is the value at the midpoint of the output shaft. Refer to pages F-11~12 when radial load is off the midpoint of output shaft and for checking thrust load.
 3. Refer to pages F-15~16 for allowable radial load for input shaft.

Selection Tables 6000 Series Reducer

Single Reduction Ratio 6 ~ 119 Frame Size: 6060 ~ 6120

Input Speed	$n_1 = 50$ r/min	n_1 : Input Speed [r/min]	T_{out} : Allowable output torque [N·m, kgf·m]
		n_2 : Output Speed [r/min]	Pro: Allowable output shaft radial load [N, kgf]
		P_i : Allowable input power [kW]	*Consult us for Pro of CNF and CHF type.

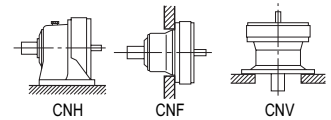

Selection Tables
Ratio 6 - 119
REDUCERS

Frame Size	n_2 [r/min] Ratio[Z]	8.33	6.25	4.55	3.85	3.33	2.94	2.38	2.00	1.72	1.43	1.16	0.980	0.847	0.704	0.575	0.420	Dim. Page	
		6	8	11	13	15	17	21	25	29	35	43	51	59	71	87	119		
6060	P_i [kW]	-	-	-	-	-	-	-	-	-	-	-	-	-	-	-	-	CNH C-71	
	T_{out} [N·m]	24.0	24.0	24.0	24.0	24.0	24.0	24.0	24.0	24.0	24.0	24.0	-	-	-	-	-	CNF C-76	
	T_{out} [kgf·m]	2.45	2.45	2.45	2.45	2.45	2.45	2.45	2.45	2.45	2.45	2.45	-	-	-	-	-	CNV C-82	
	Pro[N]	969	1010	1180	1180	1180	1180	1180	1180	1180	1180	1180	-	-	-	-	-		
	Pro[kgf]	98.8	103	120	120	120	120	120	120	120	120	-	-	-	-	-	-		
6065	P_i [kW]	-	-	-	-	-	-	-	-	-	-	-	-	-	-	-	-	CNH C-71	
	T_{out} [N·m]	25.0	27.1	30.0	30.0	30.0	30.0	30.0	30.0	30.0	30.0	30.0	-	-	-	-	-	CNF C-76	
	T_{out} [kgf·m]	2.55	2.76	3.06	3.06	3.06	3.06	3.06	3.06	3.06	3.06	3.06	-	-	-	-	-	CNV C-82	
	Pro[N]	958	974	1140	1180	1180	1180	1180	1180	1180	1180	1180	-	-	-	-	-		
	Pro[kgf]	97.7	99	116	120	120	120	120	120	120	120	-	-	-	-	-	-		
6070	P_i [kW]	-	-	-	-	-	-	-	-	-	-	-	-	-	-	-	-	CNH C-71	
	T_{out} [N·m]	29.7	43.7	45.0	45.0	45.0	45.0	45.0	45.0	45.0	45.0	45.0	45	45	-	-	-	CNF C-76	
	T_{out} [kgf·m]	3.03	4.45	4.59	4.59	4.59	4.59	4.59	4.59	4.59	4.59	4.59	5	5	-	-	-	CNV C-82	
	Pro[N]	1770	1770	1770	1770	1770	1770	1770	1770	1770	1770	1770	1750	1770	-	-	-		
	Pro[kgf]	180.0	180	180	180	180	180	180	180	180	180	180	178	180	-	-	-		
6075	P_i [kW]	-	-	-	-	-	-	-	-	-	-	-	-	-	-	-	-	CNH C-71	
	T_{out} [N·m]	29.7	43.7	50.8	60.0	60.0	60.0	60.0	60.0	60.0	60.0	60.0	57	57	-	-	-	CNF C-76	
	T_{out} [kgf·m]	3.03	4.45	5.18	6.12	6.12	6.12	6.12	6.12	6.12	6.12	6.12	6	6	-	-	-	CNV C-82	
	Pro[N]	1770	1770	1770	1770	1770	1770	1770	1770	1770	1770	1770	1660	1580	1580	-	-		
	Pro[kgf]	180.0	180	180	180	180	180	180	180	180	180	169	161	161	-	-	-		
6080	P_i [kW]	-	-	-	-	-	-	-	-	-	-	-	-	-	-	-	-	CNH C-71	
	T_{out} [N·m]	78.5	80.0	80.0	80.0	80.0	80.0	77.2	80.0	80.0	80.0	80.0	80	80	80	80	-	CNF C-76	
	T_{out} [kgf·m]	8.00	8.15	8.15	8.15	8.15	8.15	7.87	8.15	8.15	8.15	8.15	8	8	8	8	-	CNV C-82	
	Pro[N]	2560	2560	2560	2560	2560	2560	2560	2560	2500	2560	2540	2480	2510	2460	2450	-		
	Pro[kgf]	261.0	261	261	261	261	261	261	255	261	259	253	256	251	250	-	-		
6085	P_i [kW]	-	-	-	-	-	-	-	-	-	-	-	-	-	-	-	-	CNH C-71	
	T_{out} [N·m]	78.5	99.2	100.0	100.0	100.0	100.0	77.2	100.0	100.0	100.0	100.0	100	100	100	100	-	CNF C-76	
	T_{out} [kgf·m]	8.00	10.10	10.20	10.20	10.20	10.20	7.87	10.20	10.20	10.20	10.20	10	10	10	10	-	CNV C-82	
	Pro[N]	2560	2560	2560	2560	2560	2560	2560	2360	2300	2420	2340	2290	2310	2260	2260	-		
	Pro[kgf]	261.0	261	261	261	261	261	241	234	247	239	233	235	230	230	-	-		
6090	P_i [kW]	-	-	-	-	-	-	-	-	-	-	-	-	-	-	-	-	CNH C-71	
	T_{out} [N·m]	142.0	150.0	150.0	150.0	150.0	150.0	150.0	150.0	150.0	150.0	150.0	149	146	132	150	108	CNF C-76	
	T_{out} [kgf·m]	14.50	15.30	15.30	15.30	15.30	15.30	15.30	15.30	15.30	15.30	15.30	15	15	14	15	11	CNV C-82	
	Pro[N]	3340	3340	3340	3340	3340	3340	3340	3280	3290	3300	3310	3280	3300	3310	3310	3310	-	
	Pro[kgf]	340.0	340	340	340	340	340	340	334	335	336	337	334	336	337	337	-		
6095	P_i [kW]	-	-	-	-	-	-	-	-	-	-	-	-	-	-	-	-	CNH C-71	
	T_{out} [N·m]	170.0	168.0	200.0	200.0	200.0	200.0	200.0	200.0	200.0	200.0	200.0	153	146	132	195	108	CNF C-76	
	T_{out} [kgf·m]	17.30	17.10	20.40	20.40	20.40	20.40	20.40	20.40	20.40	20.40	20.40	16	15	14	20	11	CNV C-82	
	Pro[N]	3340	3340	3340	3340	3340	3340	3340	3180	3200	3200	3220	3280	3300	3310	3230	3310	-	
	Pro[kgf]	340.0	340	340	340	340	340	324	326	326	328	334	336	337	329	337	-		
6100	P_i [kW]	-	-	-	-	-	-	-	-	-	-	-	-	-	-	-	-	CNH C-71	
	T_{out} [N·m]	171.0	250.0	250.0	250.0	250.0	250.0	250.0	250.0	250.0	250.0	250.0	250	250	250	250	250	CNF C-76	
	T_{out} [kgf·m]	17.40	25.50	25.50	25.50	25.50	25.50	25.50	25.50	25.50	25.50	25.50	26	26	26	26	26	CNV C-82	
	Pro[N]	5400	5400	5400	5400	5400	5400	5400	5400	5400	5400	5400	5400	5400	5380	5400	5360	-	
	Pro[kgf]	550.0	550	550	550	550	550	550	550	550	550	550	550	550	548	550	546	-	
6105	P_i [kW]	-	-	-	-	-	-	-	-	-	-	-	-	-	-	-	-	CNH C-71	
	T_{out} [N·m]	171.0	276.0	308.0	300.0	300.0	300.0	300.0	300.0	300.0	300.0	300.0	297	296	264	300	258	CNF C-76	
	T_{out} [kgf·m]	17.40	28.10	31.40	30.60	30.60	30.60	30.60	30.60	30.60	30.60	30.60	30	30	27	31	26	CNV C-82	
	Pro[N]	5400	5400	5400	5400	5400	5400	5400	5400	5400	5400	5400	5310	5090	5370	4780	5350	-	
	Pro[kgf]	550.0	550	550	550	550	550	550	550	550	550	541	519	547	487	545	-		
6110	P_i [kW]	-	-	-	-	-	-	-	-	-	-	-	-	-	-	-	-	CNH C-71	
	T_{out} [N·m]	193.0	360.0	360.0	360.0	360.0	360.0	360.0	360.0	360.0	360.0	360.0	360	360	360	360	-	CNF C-76	
	T_{out} [kgf·m]	19.70	36.70	36.70	36.70	36.70	36.70	36.70	36.70	36.70	36.70	36.70	37	37	37	37	-	CNV C-82	
	Pro[N]	7610	7610	7610	7610	7610	7610	7610	7340	7200	7280	7590	7590	7610	7580	7600	-		
	Pro[kgf]	776.0	776	776	776	776	776	748	734	742	774	774	776	773	775	-	-		
6115	P_i [kW]	-	-	-	-	-	-	-	-	-	-	-	-	-	-	-	-	CNH C-71	
	T_{out} [N·m]	193.0	406.0	420.0	420.0	420.0	420.0	420.0	420.0	420.0	420.0	420.0	420	420	420	420	-	CNF C-76	
	T_{out} [kgf·m]	19.70	41.40	42.80	42.80	42.80	42.80	42.80	42.80	42.80	42.80	42.80	43	43	43	43	-	CNV C-82	
	Pro[N]	7610	7610	7610	7600	7610	7500	7460	7150	7010	7090	7370	7410	7430	7390	7410	-		
	Pro[kgf]	776.0	776	776	775	776	765	760	729	715	723	751	755	757	753	755	-		
6120	P_i [kW]	-	-	-	-	-	-	-	-	-	-	-	-	-	-	-	-	CNH C-71	
	T_{out} [N·m]	366	525	525	525	525	520	522	525	520	525	525	525	525	525	525	-	CNF C-76	
	T_{out} [kgf·m]	37.3	53.5	53.5	53.5	53.5	53.0	53.2	53.5	53.0	53.5	53.5	53.5	53.5	53.5	53.5	-	CNV C-82	
	Pro[N]	9810	9810	9810	9810	9810	9810	9810	9810	9810	9810	9810	9810	9810	9810	9780	-		
	Pro[kgf]	1000	1000	1000	1000	1000	1000	1000	1000	1000	1000	1000	1000	1000	997	-	-		

Note: 1. Allowable radial load Pro is the value at the midpoint of the output shaft. Refer to pages F-11~12 when radial load is off the midpoint of output shaft and for checking thrust load.

2. Refer to pages F-15~16 for allowable radial load for input shaft.

Selection Tables 6000 Series Reducer

Single Reduction Ratio 6 ~ 119 Frame Size: 6125 ~ 6195

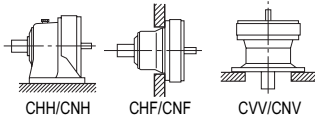

n_1 : Input Speed [r/min] T_{out} : Allowable output torque [N·m, kgf·m]
 n_2 : Output Speed [r/min] Pro: Allowable output shaft radial load [N, kgf]
 P_1 : Allowable input power [kW] *Consult us for Pro of CNF and CHF type.

Input Speed $n_1 = 50$ r/min

Frame Size	n_2 [r/min] Ratio[Z]	8.33	6.25	4.55	3.85	3.33	2.94	2.38	2.00	1.72	1.43	1.16	0.980	0.847	0.704	0.575	0.420	Dim. Page	
6125	P_1 [kW]	-	-	-	-	-	-	-	-	-	-	-	-	-	-	-	-	CNH C-71 CNF C-76 CNV C-82	
	T_{out} [N·m]	366	574	622	630	630	630	630	630	630	630	630	630	630	592	630	-		
	T_{out} [kgf·m]	37.3	58.5	63.4	64.2	64.2	64.2	64.2	64.2	64.2	64.2	64.2	64.2	64.2	60.3	64.2	-		
	Pro[N]	9810	9810	9810	9810	9810	9810	9810	9810	9810	9810	9810	9810	9810	9810	9810	9560		-
	Pro[kgf]	1000	1000	1000	1000	1000	1000	1000	1000	1000	1000	1000	1000	1000	1000	1000	975		-
6130	P_1 [kW]	-	-	-	-	-	-	-	-	-	-	-	-	-	-	-	-	CHH C-72 CHF C-77 CVV C-83	
	T_{out} [N·m]	555	744	780	780	780	780	780	780	780	780	780	928	912	902	848	-		
	T_{out} [kgf·m]	56.6	75.8	79.5	79.5	79.5	79.5	79.5	79.5	79.5	79.5	79.5	94.6	93.0	91.9	86.4	-		
	Pro[N]	14700	14700	14700	14700	14700	14700	14700	14700	14700	14700	14700	14700	14700	14700	14700	14700		-
	Pro[kgf]	1500	1500	1500	1500	1500	1500	1500	1500	1500	1500	1500	1500	1500	1500	1500	1500		-
6135	P_1 [kW]	-	-	-	-	-	-	-	-	-	-	-	-	-	-	-	-	CHH C-72 CHF C-77 CVV C-83	
	T_{out} [N·m]	607	764	940	940	940	940	940	900	940	940	940	967	1050	1040	979	-		
	T_{out} [kgf·m]	61.9	77.9	95.8	95.8	95.8	95.8	95.8	91.7	95.8	95.8	95.8	98.6	107	106	99.8	-		
	Pro[N]	14700	14700	14700	14700	14700	14700	14700	14700	14700	14700	14700	14700	14700	14700	14700	14700		-
	Pro[kgf]	1500	1500	1500	1500	1500	1500	1500	1500	1500	1500	1500	1500	1500	1500	1500	1500		-
6140	P_1 [kW]	-	-	-	-	-	-	-	-	-	-	-	-	-	-	-	-	CHH C-72 CHF C-77 CVV C-83	
	T_{out} [N·m]	717	1150	1230	1230	1230	1230	1230	1230	1230	1230	1230	1230	1230	1230	1230	1230		-
	T_{out} [kgf·m]	73.1	117	125	125	125	125	125	125	125	125	125	125	125	125	125	125		-
	Pro[N]	16000	16000	16000	16000	16000	16000	16000	16000	16000	16000	16000	16000	16000	16000	16000	16000		-
	Pro[kgf]	1630	1630	1630	1630	1630	1630	1630	1630	1630	1630	1630	1630	1630	1630	1630	1630		-
6145	P_1 [kW]	-	-	-	-	-	-	-	-	-	-	-	-	-	-	-	-	CHH C-72 CHF C-77 CVV C-83	
	T_{out} [N·m]	717	1150	1290	1370	1360	1370	1340	1370	1370	1370	1370	1370	1370	1370	1320	1250		-
	T_{out} [kgf·m]	73.1	117	131	140	139	140	137	140	140	140	140	140	140	140	135	127		-
	Pro[N]	16000	16000	16000	15900	16000	16000	16000	16000	15800	16000	15700	15700	16000	16000	16000	16000		-
	Pro[kgf]	1630	1630	1630	1620	1630	1630	1630	1630	1610	1630	1600	1600	1630	1630	1630	1630		-
6160	P_1 [kW]	-	-	-	-	-	-	-	-	-	-	-	-	-	-	-	-	CHH C-72 CHF C-77 CVV C-84	
	T_{out} [N·m]	1320	1760	1760	1760	1760	1760	1760	1760	1760	1760	1740	1760	1760	1760	1760	-		
	T_{out} [kgf·m]	135	179	179	179	179	179	179	179	179	179	177	179	179	179	179	-		
	Pro[N]	22100	22100	22100	22100	22100	22100	22100	22100	22100	22100	22100	22100	22100	22100	22100	22100		-
	Pro[kgf]	2250	2250	2250	2250	2250	2250	2250	2250	2250	2250	2250	2250	2250	2250	2250	2250		-
6165	P_1 [kW]	-	-	-	-	-	-	-	-	-	-	-	-	-	-	-	-	CHH C-72 CHF C-77 CVV C-84	
	T_{out} [N·m]	1320	1870	2100	2100	2100	2100	2100	2100	2100	2100	2100	2100	2100	2100	2050	-		
	T_{out} [kgf·m]	135	191	214	214	214	214	214	214	214	214	214	214	214	214	209	-		
	Pro[N]	22100	22100	22100	22100	22100	22100	22100	22100	22100	22100	22100	22100	22100	22100	21800	-		
	Pro[kgf]	2250	2250	2250	2250	2250	2250	2250	2250	2250	2250	2250	2250	2250	2250	2220	-		
6170	P_1 [kW]	-	-	-	-	-	-	-	-	-	-	-	-	-	-	-	-	CHH C-72 CHF C-77 CVV C-84	
	T_{out} [N·m]	1860	2530	2530	2530	2530	2530	2530	2530	2530	2530	2530	2530	2530	2530	2530	2530		-
	T_{out} [kgf·m]	190	258	258	258	258	258	258	258	258	258	258	258	258	258	258	258		-
	Pro[N]	29500	29500	29500	29500	29500	29500	29500	29500	29500	29500	29500	29500	29500	29500	29500	29500		-
	Pro[kgf]	3010	3010	3010	3010	3010	3010	3010	3010	3010	3010	3010	3010	3010	3010	3010	3010		-
6175	P_1 [kW]	-	-	-	-	-	-	-	-	-	-	-	-	-	-	-	-	CHH C-72 CHF C-77 CVV C-84	
	T_{out} [N·m]	1860	2600	3150	3150	3150	3150	3150	3150	3150	3150	3150	3150	3150	3150	3150	3150		-
	T_{out} [kgf·m]	190	265	321	321	321	321	321	321	321	321	321	321	321	321	321	321		-
	Pro[N]	29500	29500	29500	29500	29500	29500	29500	29500	29500	29500	29500	29500	29500	29500	29500	29500		-
	Pro[kgf]	3010	3010	3010	3010	3010	3010	3010	3010	3010	3010	3010	3010	3010	3010	3010	3010		-
6180	P_1 [kW]	-	-	-	-	-	-	-	-	-	-	-	-	-	-	-	-	CHH C-72 CHF C-77 CVV C-84	
	T_{out} [N·m]	-	-	4060	4060	4060	4060	4050	4050	4050	4050	4060	4050	4050	4050	4060	-		
	T_{out} [kgf·m]	-	-	414	414	414	414	413	413	413	413	414	413	413	413	414	-		
	Pro[N]	-	-	41700	41700	41700	41700	41700	41700	41700	41700	41700	41700	41700	41700	41700	41700		-
	Pro[kgf]	-	-	4250	4250	4250	4250	4250	4250	4250	4250	4250	4250	4250	4250	4250	4250		-
6185	P_1 [kW]	-	-	-	-	-	-	-	-	-	-	-	-	-	-	-	-	CHH C-72 CHF C-77 CVV C-84	
	T_{out} [N·m]	-	-	4810	4900	4920	5000	5000	5000	5000	5000	5000	5000	5000	5000	4510	5000		-
	T_{out} [kgf·m]	-	-	490	499	502	510	510	510	510	510	510	510	510	510	460	510		-
	Pro[N]	-	-	41700	41700	41700	41700	41700	41700	41700	41700	41700	41700	41700	41600	41700	41700		-
	Pro[kgf]	-	-	4250	4250	4250	4250	4250	4250	4250	4250	4250	4250	4250	4240	4250	4250		-
6190	P_1 [kW]	-	-	-	-	-	-	-	-	-	-	-	-	-	-	-	-	CHH C-72 CHF C-77 CVV C-84	
	T_{out} [N·m]	-	-	6380	6380	6380	6380	6380	6380	6380	6380	6380	6380	6380	6380	6380	6380		-
	T_{out} [kgf·m]	-	-	650	650	650	650	650	650	650	650	650	650	650	650	650	650		-
	Pro[N]	-	-	59000	58700	58900	59000	59000	59000	59000	59000	59000	59000	58700	58600	58400	58900		-
	Pro[kgf]	-	-	6010	5980	6000	6010	6010	6010	6010	6010	6010	6010	5980	5970	5950	6000		-
6195	P_1 [kW]	-	-	-	-	-	-	-	-	-	-	-	-	-	-	-	-	CHH C-72 CHF C-77 CVV C-84	
	T_{out} [N·m]	-	-	7580	7630	7910	7960	7960	7960	7960	7960	7960	7960	7960	7960	7960	7960		-
	T_{out} [kgf·m]	-	-	773	778	806	811	811	811	811	811	811	811	811	811	811	811		-
	Pro[N]	-	-	59000	58200	58300	59000	59000	59000	59000	59000	58600	59000	58200	58100	58000	58400		-
	Pro[kgf]	-	-	6010	5930	5940	6010	6010	6010	6010	6010	5970	6010	5930	5920	5910	5950		-
Frame Size	Ratio[Z]	6	8	11	13	15	17	21	25	29	35	43	51	59	71	87	119	Dim. Page	
	n_2 [r/min]	8.33	6.25	4.55	3.85	3.33	2.94	2.38	2.00	1.72	1.43	1.16	0.980	0.847	0.704	0.575	0.420		

Note: 1. Allowable radial load Pro is the value at the midpoint of the output shaft. Refer to pages F-11~12 when radial load is off the midpoint of output shaft and for checking thrust load.
 2. Refer to pages F-15~16 for allowable radial load for input shaft.

Selection Tables 6000 Series Reducer

Single Reduction Ratio 6 ~ 119 Frame Size: 6205 ~ 6275

Input Speed	$n_1 = 50$ r/min	n_1 : Input Speed [r/min]	T_{out} : Allowable output torque [N·m, kgf·m]
		n_2 : Output Speed [r/min]	Pro: Allowable output shaft radial load [N, kgf]
		P_1 : Allowable input power [kW]	*Consult us for Pro of CNF and CHF type.

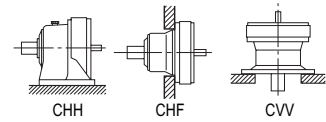

Selection Tables
Ratio 6 - 119
REDUCERS

Frame Size	n_2 [r/min] Ratio[Z]	8.33	6.25	4.55	3.85	3.33	2.94	2.38	2.00	1.72	1.43	1.16	0.980	0.847	0.704	0.575	0.420	Dim. Page	
		6	8	11	13	15	17	21	25	29	35	43	51	59	71	87	119		
6205	P_1 [kW]	-	-	-	-	-	-	-	-	-	-	-	-	-	-	-	-	-	CHH C-72 CHF C-77 CVW C-84
	T_{out} [N·m]	-	-	8620	-	9270	-	9270	-	9230	-	9300	-	9300	-	8760	-	-	
	T_{out} [kgf·m]	-	-	879	-	945	-	945	-	941	-	948	-	948	-	893	-	-	
	Pro [N]	-	-	84100	-	84100	-	84100	-	84100	-	84100	-	84100	-	84100	-	-	
	Pro [kgf]	-	-	8570	-	8570	-	8570	-	8570	-	8570	-	8570	-	8570	-	-	
6215	P_1 [kW]	-	-	-	-	-	-	-	-	-	-	-	-	-	-	-	-	-	CHH C-72 CHF C-77 CVW C-84
	T_{out} [N·m]	-	-	11400	-	12200	-	12500	-	12700	-	12700	-	12700	-	11300	-	-	
	T_{out} [kgf·m]	-	-	1160	-	1240	-	1270	-	1290	-	1290	-	1290	-	1150	-	-	
	Pro [N]	-	-	104000	-	104000	-	104000	-	104000	-	104000	-	104000	-	104000	-	-	
	Pro [kgf]	-	-	10600	-	10600	-	10600	-	10600	-	10600	-	10600	-	10600	-	-	
6225	P_1 [kW]	-	-	-	-	-	-	-	-	-	-	-	-	-	-	-	-	-	CHH C-72 CHF C-77 CVW C-84
	T_{out} [N·m]	-	-	13500	-	14500	-	14800	-	15000	-	16000	-	15900	-	15100	-	-	
	T_{out} [kgf·m]	-	-	1380	-	1480	-	1510	-	1530	-	1630	-	1620	-	1540	-	-	
	Pro [N]	-	-	145000	-	145000	-	145000	-	145000	-	145000	-	145000	-	145000	-	-	
	Pro [kgf]	-	-	14800	-	14800	-	14800	-	14800	-	14800	-	14800	-	14800	-	-	
6235	P_1 [kW]	-	-	-	-	-	-	-	-	-	-	-	-	-	-	-	-	-	CHH C-72 CHF C-77 CVW C-84
	T_{out} [N·m]	-	-	18700	-	19600	-	18900	-	18900	-	20500	-	20500	-	17200	-	-	
	T_{out} [kgf·m]	-	-	1910	-	2000	-	1930	-	1930	-	2090	-	2090	-	1750	-	-	
	Pro [N]	-	-	179000	-	179000	-	179000	-	179000	-	179000	-	179000	-	179000	-	-	
	Pro [kgf]	-	-	18200	-	18200	-	18200	-	18200	-	18200	-	18200	-	18200	-	-	
6245	P_1 [kW]	-	-	-	-	-	-	-	-	-	-	-	-	-	-	-	-	-	CHH C-72 CHF C-77 CVW C-84
	T_{out} [N·m]	-	-	20500	-	26200	-	25800	-	25800	-	25800	-	25800	-	22600	-	-	
	T_{out} [kgf·m]	-	-	2090	-	2670	-	2630	-	2630	-	2630	-	2630	-	2300	-	-	
	Pro [N]	-	-	208000	-	208000	-	208000	-	208000	-	208000	-	208000	-	208000	-	-	
	Pro [kgf]	-	-	21200	-	21200	-	21200	-	21200	-	21200	-	21200	-	21200	-	-	
6255	P_1 [kW]	-	-	-	-	-	-	-	-	-	-	-	-	-	-	-	-	-	CHH C-72 CHF C-77 CVW C-84
	T_{out} [N·m]	-	-	27500	-	31200	-	31000	-	32500	-	34500	-	34500	-	31000	-	-	
	T_{out} [kgf·m]	-	-	2800	-	3180	-	3160	-	3310	-	3520	-	3520	-	3160	-	-	
	Pro [N]	-	-	257000	-	258000	-	258000	-	258000	-	258000	-	258000	-	258000	-	-	
	Pro [kgf]	-	-	26200	-	26300	-	26300	-	26300	-	26300	-	26300	-	26300	-	-	
6265	P_1 [kW]	-	-	-	-	-	-	-	-	-	-	-	-	-	-	-	-	-	CHH C-72 CHF C-77 CVW C-84
	T_{out} [N·m]	-	-	31300	-	43700	-	46000	-	46000	-	46000	-	46000	-	44000	-	-	
	T_{out} [kgf·m]	-	-	3190	-	4450	-	4690	-	4690	-	4690	-	4690	-	4490	-	-	
	Pro [N]	-	-	276000	-	276000	-	276000	-	276000	-	276000	-	276000	-	276000	-	-	
	Pro [kgf]	-	-	28100	-	28100	-	28100	-	28100	-	28100	-	28100	-	28100	-	-	
6275	P_1 [kW]	-	-	-	-	-	-	-	-	-	-	-	-	-	-	-	-	-	CHH C-72 CVW C-84
	T_{out} [N·m]	-	-	-	-	-	-	-	-	68200	-	68200	-	68200	-	68200	-	-	
	T_{out} [kgf·m]	-	-	-	-	-	-	-	-	6950	-	6950	-	6950	-	6950	-	-	
	Pro [N]	-	-	-	-	-	-	-	-	248000	-	248000	-	248000	-	245000	-	-	
	Pro [kgf]	-	-	-	-	-	-	-	25300	-	25300	-	25300	-	25000	-	-		

Note: 1. Allowable radial load Pro is the value at the midpoint of the output shaft. Refer to pages F-11~12 when radial load is off the midpoint of output shaft and for checking thrust load.
2. Refer to pages F-15~16 for allowable radial load for input shaft.

Selection Tables 6000 Series Reducer

Single Reduction Ratio 6 ~ 119 Frame Size: 6060 ~ 6120

Input Speed	$n_1 = 580$ r/min	n_1 : Input Speed [r/min]	T_{out} : Allowable output torque [N·m, kgf·m]
		n_2 : Output Speed [r/min]	Pro: Allowable output shaft radial load [N, kgf]
		P_i : Allowable input power [kW]	*Consult us for Pro of CNF and CHF type.

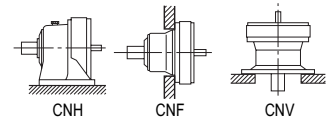

Selection Tables
Ratio 6 - 119
REDUCERS

Frame Size	n_2 [r/min] Ratio[Z]	96.7	72.5	52.7	44.6	38.7	34.1	27.6	23.2	20.0	16.6	13.5	11.4	9.83	8.17	6.67	4.87	Dim. Page	
		6	8	11	13	15	17	21	25	29	35	43	51	59	71	87	119		
6060	P_i [kW]	0.200	0.192	0.139	0.118	0.102	0.090	0.073	0.061	0.053	0.044	0.036	-	-	-	-	-	-	CNH C-71 CNF C-76 CNV C-82
	T_{out} [N·m]	18.8	24.0	24.0	24.0	24.0	24.0	24.0	24.0	24.0	24.0	24.0	-	-	-	-	-	-	
	T_{out} [kgf·m]	1.92	2.45	2.45	2.45	2.45	2.45	2.45	2.45	2.45	2.45	2.45	-	-	-	-	-	-	
	Pro[N]	1020	1010	1180	1180	1180	1180	1180	1180	1180	1180	1180	-	-	-	-	-	-	
	Pro[kgf]	104	103	120	120	120	120	120	120	120	120	120	-	-	-	-	-	-	
6065	P_i [kW]	0.267	0.216	0.174	0.148	0.128	0.113	0.091	0.077	0.066	0.055	0.045	-	-	-	-	-	-	CNH C-71 CNF C-76 CNV C-82
	T_{out} [N·m]	25.0	27.1	30.0	30.0	30.0	30.0	30.0	30.0	30.0	30.0	30.0	-	-	-	-	-	-	
	T_{out} [kgf·m]	2.55	2.76	3.06	3.06	3.06	3.06	3.06	3.06	3.06	3.06	3.06	-	-	-	-	-	-	
	Pro[N]	958	974	1140	1180	1180	1180	1180	1180	1180	1180	1180	-	-	-	-	-	-	
	Pro[kgf]	97.7	99.3	116	120	120	120	120	120	120	120	120	-	-	-	-	-	-	
6070	P_i [kW]	0.316	0.288	0.262	0.221	0.192	0.169	0.137	0.115	0.099	0.082	0.067	0.056	0.049	-	-	-	-	CNH C-71 CNF C-76 CNV C-82
	T_{out} [N·m]	29.7	36.1	45.0	45.0	45.0	45.0	45.0	45.0	45.0	45.0	45.0	45.0	45.0	-	-	-	-	
	T_{out} [kgf·m]	3.03	3.68	4.59	4.59	4.59	4.59	4.59	4.59	4.59	4.59	4.59	4.59	4.59	-	-	-	-	
	Pro[N]	1770	1770	1770	1770	1770	1770	1770	1770	1770	1770	1770	1770	1750	1770	-	-	-	
	Pro[kgf]	180	180	180	180	180	180	180	180	180	180	180	180	178	180	-	-	-	
6075	P_i [kW]	0.316	0.288	0.291	0.273	0.256	0.226	0.183	0.153	0.132	0.110	0.089	0.071	0.062	-	-	-	-	CNH C-71 CNF C-76 CNV C-82
	T_{out} [N·m]	29.7	36.1	50.1	55.5	60.0	60.0	60.0	60.0	60.0	60.0	60.0	56.9	57.4	-	-	-	-	
	T_{out} [kgf·m]	3.03	3.68	5.11	5.66	6.12	6.12	6.12	6.12	6.12	6.12	6.12	5.80	5.85	-	-	-	-	
	Pro[N]	1770	1770	1770	1770	1770	1770	1770	1770	1770	1770	1770	1660	1580	1580	-	-	-	
	Pro[kgf]	180	180	180	180	180	180	180	180	180	180	180	169	161	161	-	-	-	
6080	P_i [kW]	0.592	0.592	0.465	0.393	0.341	0.301	0.235	0.205	0.176	0.146	0.119	0.100	0.087	0.072	0.059	-	-	CNH C-71 CNF C-76 CNV C-82
	T_{out} [N·m]	55.6	74.1	80.0	80.0	80.0	80.0	77.2	80.0	80.0	80.0	80.0	80.0	80.0	80.0	80.0	-	-	
	T_{out} [kgf·m]	5.67	7.55	8.15	8.15	8.15	8.15	7.87	8.15	8.15	8.15	8.15	8.15	8.15	8.15	8.15	-	-	
	Pro[N]	2540	2560	2560	2560	2560	2560	2560	2560	2500	2560	2540	2480	2510	2460	2450	-	-	
	Pro[kgf]	259	261	261	261	261	261	261	261	255	261	259	253	256	251	250	-	-	
6085	P_i [kW]	0.778	0.778	0.581	0.492	0.426	0.376	0.235	0.256	0.220	0.183	0.149	0.125	0.108	0.090	0.073	-	-	CNH C-71 CNF C-76 CNV C-82
	T_{out} [N·m]	73.0	97.3	100	100	100	100	77.2	100	100	100	100	100	100	100	100	-	-	
	T_{out} [kgf·m]	7.44	9.92	10.2	10.2	10.2	10.2	7.87	10.2	10.2	10.2	10.2	10.2	10.2	10.2	10.2	-	-	
	Pro[N]	2510	2560	2560	2560	2560	2560	2560	2360	2300	2420	2340	2290	2310	2260	2260	-	-	
	Pro[kgf]	256	261	261	261	261	261	261	241	234	247	239	233	235	230	230	-	-	
6090	P_i [kW]	1.15	1.15	0.872	0.738	0.639	0.564	0.457	0.384	0.331	0.274	0.223	0.186	0.158	0.119	0.110	0.058	-	CNH C-71 CNF C-76 CNV C-82
	T_{out} [N·m]	108	143	150	150	150	150	150	150	150	150	150	149	146	132	150	108	-	
	T_{out} [kgf·m]	11.0	14.6	15.3	15.3	15.3	15.3	15.3	15.3	15.3	15.3	15.3	15.2	14.9	13.5	15.3	11.0	-	
	Pro[N]	3340	3340	3340	3340	3340	3340	3340	3280	3290	3300	3310	3280	3300	3310	3310	3310	-	
	Pro[kgf]	340	340	340	340	340	340	340	334	335	336	337	334	336	337	337	337	-	
6095	P_i [kW]	1.47	1.34	1.05	0.984	0.852	0.752	0.609	0.499	0.441	0.365	0.297	0.192	0.158	0.119	0.131	0.058	-	CNH C-71 CNF C-76 CNV C-82
	T_{out} [N·m]	138	168	181	200	200	200	200	195	200	200	200	153	146	132	178	108	-	
	T_{out} [kgf·m]	14.1	17.1	18.5	20.4	20.4	20.4	20.4	19.9	20.4	20.4	20.4	15.6	14.9	13.5	18.1	11.0	-	
	Pro[N]	3340	3340	3340	3340	3340	3340	3340	3190	3200	3200	3220	3280	3300	3310	3270	3310	-	
	Pro[kgf]	340	340	340	340	340	340	340	325	326	326	328	334	336	337	333	337	-	
6100	P_i [kW]	1.82	1.86	1.45	1.23	1.07	0.940	0.761	0.639	0.551	0.457	0.372	0.313	0.271	0.225	0.184	0.134	-	CNH C-71 CNF C-76 CNV C-82
	T_{out} [N·m]	171	233	250	250	250	250	250	250	250	250	250	250	250	250	250	250	-	
	T_{out} [kgf·m]	17.4	23.8	25.5	25.5	25.5	25.5	25.5	25.5	25.5	25.5	25.5	25.5	25.5	25.5	25.5	25.5	-	
	Pro[N]	5400	5400	5400	5400	5400	5400	5400	5400	5400	5400	5400	5400	5400	5400	5380	5400	5360	
	Pro[kgf]	550	550	550	550	550	550	550	550	550	550	550	550	550	550	548	550	546	
6105	P_i [kW]	1.82	1.86	1.79	1.48	1.28	1.13	0.913	0.767	0.661	0.548	0.446	0.372	0.321	0.238	0.220	0.139	-	CNH C-71 CNF C-76 CNV C-82
	T_{out} [N·m]	171	233	308	300	300	300	300	300	300	300	300	297	296	264	300	258	-	
	T_{out} [kgf·m]	17.4	23.8	31.4	30.6	30.6	30.6	30.6	30.6	30.6	30.6	30.6	30.3	30.2	26.9	30.6	26.3	-	
	Pro[N]	5400	5400	5400	5400	5400	5400	5400	5400	5400	5400	5400	5310	5090	5370	4780	5350	-	
	Pro[kgf]	550	550	550	550	550	550	550	550	550	550	550	541	519	547	487	545	-	
6110	P_i [kW]	2.06	2.88	2.09	1.77	1.53	1.35	1.10	0.921	0.794	0.658	0.535	0.451	0.390	0.324	0.265	-	-	CNH C-71 CNF C-76 CNV C-82
	T_{out} [N·m]	193	360	360	360	360	360	360	360	360	360	360	360	360	360	360	-	-	
	T_{out} [kgf·m]	19.7	36.7	36.7	36.7	36.7	36.7	36.7	36.7	36.7	36.7	36.7	36.7	36.7	36.7	36.7	-	-	
	Pro[N]	6210	6780	7610	7610	7610	7610	7610	7340	7200	7280	7590	7590	7610	7580	7600	-	-	
	Pro[kgf]	633	691	776	776	776	776	776	748	734	742	774	774	776	773	775	-	-	
6115	P_i [kW]	2.06	3.25	2.44	2.07	1.79	1.58	1.28	1.07	0.926	0.767	0.624	0.526	0.455	0.378	0.309	-	-	CNH C-71 CNF C-76 CNV C-82
	T_{out} [N·m]	193	406	420	420	420	420	420	420	420	420	420	420	420	420	420	-	-	
	T_{out} [kgf·m]	19.7	41.4	42.8	42.8	42.8	42.8	42.8	42.8	42.8	42.8	42.8	42.8	42.8	42.8	42.8	-	-	
	Pro[N]	6210	6720	7610	7600	7610	7500	7460	7150	7010	7090	7370	7410	7430	7390	7410	-	-	
	Pro[kgf]	633	685	776	775	776	765	760	729	715	723	751	755	757	753	755	-	-	
6120	P_i [kW]	3.90	4.00	3.05	2.58	2.24	1.96	1.59	1.34	1.15	0.959	0.781	0.658	0.569	0.473	0.386	-	-	CNH C-71 CNF C-76 CNV C-82
	T_{out} [N·m]	366	501	525	525	525	520	522	525	520	525	525	525	525	525	525	-	-	
	T_{out} [kgf·m]	37.3	51.1	53.5	53.5	53.5	53.0	53.2	53.5	53.0	53.5	53.5	53.5	53.5	53.5	53.5	-	-	
	Pro[N]	6880	7620	8740	9090	9810	9810	9810	9810	9810	9810	9810	9810	9810	9810	9780	-	-	
	Pro[kgf]	701	777	891	927	1000	1000	1000	1000	1000	1000	1000	1000	1000	1000	997	-	-	

Note: 1. Allowable radial load Pro is the value at the midpoint of the output shaft. Refer to pages F-11~12 when radial load is off the midpoint of output shaft and for checking thrust load.

2. Refer to pages F-15~16 for allowable radial load for input shaft.

Selection Tables 6000 Series Reducer

Single Reduction Ratio 6 ~ 119 Frame Size: 6125 ~ 6195

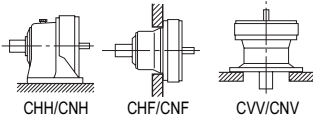

n_1 : Input Speed [r/min] T_{out} : Allowable output torque [N·m, kgf·m]
 n_2 : Output Speed [r/min] Pro: Allowable output shaft radial load [N, kgf]
 P_1 : Allowable input power [kW] *Consult us for Pro of CNF and CHF type.

Input Speed $n_1 = 580$ r/min

Frame Size	n_2 [r/min]	96.7	72.5	52.7	44.6	38.7	34.1	27.6	23.2	20.0	16.6	13.5	11.4	9.83	8.17	6.67	4.87	Dim. Page	
	Ratio[Z]	6	8	11	13	15	17	21	25	29	35	43	51	59	71	87	119		
6125	P_1 [kW]	3.90	4.00	3.47	3.10	2.69	2.37	1.92	1.61	1.39	1.15	0.937	0.790	0.683	0.533	0.463	-	- CNH C-71 CNF C-76 CNV C-82	
	T_{out} [N·m]	366	501	596	630	630	630	630	630	630	630	630	630	630	592	630	-		
	T_{out} [kgf·m]	37.3	51.1	60.8	64.2	64.2	64.2	64.2	64.2	64.2	64.2	64.2	64.2	64.2	60.3	64.2	-		
	Pro[N]	6880	7620	8670	8980	9710	9810	9810	9810	9810	9810	9810	9810	9810	9810	9810	9560		-
	Pro[kgf]	701	777	884	915	990	1000	1000	1000	1000	1000	1000	1000	1000	1000	1000	975		-
6130	P_1 [kW]	5.91	5.94	4.53	3.84	3.32	2.93	2.37	1.99	1.72	1.42	1.16	1.16	0.988	0.813	0.623	-	- CHH C-72 CHF C-77 CVV C-83	
	T_{out} [N·m]	555	744	780	780	780	780	780	780	780	780	780	928	912	902	848	-		
	T_{out} [kgf·m]	56.6	75.8	79.5	79.5	79.5	79.5	79.5	79.5	79.5	79.5	79.5	94.6	93.0	91.9	86.4	-		
	Pro[N]	7930	8800	10200	10700	11000	11800	12700	13300	14000	14700	14700	14700	14700	14700	14700	14700		-
	Pro[kgf]	808	897	1040	1090	1120	1200	1290	1360	1430	1500	1500	1500	1500	1500	1500	1500		-
6135	P_1 [kW]	6.47	6.11	5.46	4.62	4.01	3.53	2.86	2.30	2.07	1.72	1.40	1.21	1.14	0.938	0.719	-	- CHH C-72 CHF C-77 CVV C-83	
	T_{out} [N·m]	607	764	940	940	940	940	940	900	940	940	940	967	1050	1040	979	-		
	T_{out} [kgf·m]	61.9	77.9	95.8	95.8	95.8	95.8	95.8	91.7	95.8	95.8	95.8	98.6	107	106	99.8	-		
	Pro[N]	7870	8780	10100	10600	10900	11700	12600	13200	13900	14700	14700	14700	14700	14700	14700	14700		-
	Pro[kgf]	802	895	1030	1080	1110	1190	1280	1350	1420	1500	1500	1500	1500	1500	1500	1500		-
6140	P_1 [kW]	7.64	7.80	7.12	6.02	5.22	4.61	3.73	3.13	2.70	2.24	1.82	1.54	1.33	1.10	0.900	-	- CHH C-72 CHF C-77 CVV C-83	
	T_{out} [N·m]	717	976	1230	1230	1230	1230	1230	1230	1230	1230	1230	1230	1230	1230	1230	-		
	T_{out} [kgf·m]	73.1	99.5	125	125	125	125	125	125	125	125	125	125	125	125	125	-		
	Pro[N]	12100	13400	15000	15500	16000	16000	16000	16000	16000	16000	16000	16000	16000	16000	16000	16000		-
	Pro[kgf]	1230	1370	1530	1580	1630	1630	1630	1630	1630	1630	1630	1630	1630	1630	1630	1630		-
6145	P_1 [kW]	7.64	7.80	7.51	6.74	5.79	5.15	4.07	3.50	3.02	2.50	2.04	1.72	1.48	1.19	0.917	-	- CHH C-72 CHF C-77 CVV C-83	
	T_{out} [N·m]	717	976	1290	1370	1360	1370	1340	1370	1370	1370	1370	1370	1370	1320	1250	-		
	T_{out} [kgf·m]	73.1	99.5	131	140	139	140	137	140	140	140	140	140	140	135	127	-		
	Pro[N]	12100	13400	15000	15400	16000	16000	16000	16000	15800	16000	15700	15700	16000	16000	16000	16000		-
	Pro[kgf]	1230	1370	1530	1570	1630	1630	1630	1630	1610	1630	1600	1600	1630	1630	1630	1630		-
6160	P_1 [kW]	14.1	14.0	10.2	8.63	7.48	6.60	5.34	4.49	3.87	3.21	2.58	2.20	1.90	1.58	1.29	-	- CHH C-72 CHF C-77 CVV C-84	
	T_{out} [N·m]	1320	1760	1760	1760	1760	1760	1760	1760	1760	1760	1740	1760	1760	1760	1760	-		
	T_{out} [kgf·m]	135	179	179	179	179	179	179	179	179	179	177	179	179	179	179	-		
	Pro[N]	13500	15000	17300	18200	19400	20100	21700	22100	22100	22100	22100	22100	22100	22100	22100	22100		-
	Pro[kgf]	1380	1530	1760	1860	1980	2050	2210	2250	2250	2250	2250	2250	2250	2250	2250	2250		-
6165	P_1 [kW]	14.1	14.9	12.2	10.3	8.95	7.90	6.39	5.37	4.63	3.84	3.12	2.63	2.28	1.89	1.51	-	- CHH C-72 CHF C-77 CVV C-84	
	T_{out} [N·m]	1320	1870	2100	2100	2100	2100	2100	2100	2100	2100	2100	2100	2100	2100	2050	-		
	T_{out} [kgf·m]	135	191	214	214	214	214	214	214	214	214	214	214	214	214	209	-		
	Pro[N]	13500	14900	17000	18000	19200	19900	21500	22100	22100	22100	22100	22100	22100	22100	21800	21800		-
	Pro[kgf]	1380	1520	1730	1830	1960	2030	2190	2250	2250	2250	2250	2250	2250	2250	2250	2220		-
6170	P_1 [kW]	19.8	20.2	14.7	12.4	10.8	9.51	7.70	6.47	5.58	4.62	3.76	3.17	2.74	2.28	1.86	-	- CHH C-72 CHF C-77 CVV C-84	
	T_{out} [N·m]	1860	2530	2530	2530	2530	2530	2530	2530	2530	2530	2530	2530	2530	2530	2530	-		
	T_{out} [kgf·m]	190	258	258	258	258	258	258	258	258	258	258	258	258	258	258	-		
	Pro[N]	15100	16500	19300	20300	21400	22400	24400	25400	26900	28700	29500	29500	29500	29500	29500	29500		-
	Pro[kgf]	1540	1680	1970	2070	2180	2280	2490	2590	2740	2930	3010	3010	3010	3010	3010	3010		-
6175	P_1 [kW]	19.8	20.8	18.3	15.5	13.4	11.8	9.59	8.06	6.94	5.75	4.68	3.95	3.41	2.84	2.31	-	- CHH C-72 CHF C-77 CVV C-84	
	T_{out} [N·m]	1860	2600	3150	3150	3150	3150	3150	3150	3150	3150	3150	3150	3150	3150	3150	-		
	T_{out} [kgf·m]	190	265	321	321	321	321	321	321	321	321	321	321	321	321	321	-		
	Pro[N]	15100	16500	18900	19900	21000	22000	24100	25100	26600	28400	29500	29500	29500	29500	29500	29500		-
	Pro[kgf]	1540	1680	1930	2030	2140	2240	2460	2560	2710	2900	3010	3010	3010	3010	3010	3010		-
6180	P_1 [kW]	-	-	23.6	20.0	17.3	15.3	12.3	10.4	8.93	7.40	6.03	5.08	4.39	3.65	2.98	-	- CHH C-72 CHF C-77 CVV C-84	
	T_{out} [N·m]	-	-	4060	4060	4060	4060	4050	4050	4050	4050	4060	4050	4050	4050	4060	-		
	T_{out} [kgf·m]	-	-	414	414	414	414	413	413	413	413	414	413	413	413	414	-		
	Pro[N]	-	-	25600	26700	28300	30000	32600	34000	35700	38200	41200	41700	41700	41700	41700	41700		-
	Pro[kgf]	-	-	2610	2720	2880	3060	3320	3470	3640	3890	4200	4250	4250	4250	4250	4250		-
6185	P_1 [kW]	-	-	27.9	24.1	19.9	18.8	15.2	12.8	11.0	9.13	7.43	6.27	5.42	4.06	3.67	-	- CHH C-72 CHF C-77 CVV C-84	
	T_{out} [N·m]	-	-	4810	4900	4670	5000	5000	5000	5000	5000	5000	5000	5000	4510	5000	-		
	T_{out} [kgf·m]	-	-	490	499	476	510	510	510	510	510	510	510	510	460	510	-		
	Pro[N]	-	-	25200	26400	28000	29600	32200	33600	35300	37900	40800	41700	41600	41700	41700	41700		-
	Pro[kgf]	-	-	2570	2690	2850	3020	3280	3430	3600	3860	4160	4250	4240	4250	4250	4250		-
6190	P_1 [kW]	-	-	37.1	31.4	27.2	24.0	19.4	16.3	14.1	11.7	9.49	8.00	6.91	5.74	4.69	-	- CHH C-72 CHF C-77 CVV C-84	
	T_{out} [N·m]	-	-	6380	6380	6380	6380	6380	6380	6380	6380	6380	6380	6380	6380	6380	-		
	T_{out} [kgf·m]	-	-	650	650	650	650	650	650	650	650	650	650	650	650	650	-		
	Pro[N]	-	-	35500	37100	39100	41500	45100	47400	49900	52900	57200	58700	58600	58400	58900	58900		-
	Pro[kgf]	-	-	3620	3780	3990	4230	4600	4830	5090	5390	5830	5980	5970	5950	6000	6000		-
6195	P_1 [kW]	-	-	44.0	36.1	33.2	29.9	24.2	20.4	17.5	14.5	11.8	9.98	8.63	7.17	5.85	-	- CHH C-72 CHF C-77 CVV C-84	
	T_{out} [N·m]	-	-	7570	7350	7800	7960	7960	796										

Selection Tables 6000 Series Reducer

Single Reduction Ratio 6 ~ 119 Frame Size: 6205 ~ 6275

Input Speed	$n_1 = 580$ r/min	n_1 : Input Speed [r/min]	T_{out} : Allowable output torque [N·m, kgf·m]
		n_2 : Output Speed [r/min]	Pro: Allowable output shaft radial load [N, kgf]
		P_1 : Allowable input power [kW]	*Consult us for Pro of CNF and CHF type.

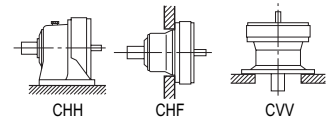

Selection Tables
Ratio 6 - 119
REDUCERS

Frame Size	n_2 [r/min] Ratio[Z]	96.7	72.5	52.7	44.6	38.7	34.1	27.6	23.2	20.0	16.6	13.5	11.4	9.83	8.17	6.67	4.87	Dim. Page
		6	8	11	13	15	17	21	25	29	35	43	51	59	71	87	119	
6205	P_1 [kW]	-	-	46.8	-	39.5	-	28.2	-	20.3	-	13.8	-	10.1	-	6.43	-	CHH C-72 CHF C-77 CVW C-84
	T_{out} [N·m]	-	-	8050	-	9270	-	9270	-	9230	-	9300	-	9300	-	8760	-	
	T_{out} [kgf·m]	-	-	821	-	945	-	945	-	941	-	948	-	948	-	893	-	
	Pro[N]	-	-	67300	-	72500	-	81600	-	84100	-	84100	-	84100	-	84100	-	
	Pro[kgf]	-	-	6860	-	7390	-	8320	-	8570	-	8570	-	8570	-	8570	-	
6215	P_1 [kW]	-	-	64.0	-	51.9	-	38.1	-	27.9	-	18.8	-	13.7	-	8.28	-	CHH C-72 CHF C-77 CVW C-84
	T_{out} [N·m]	-	-	11000	-	12200	-	12500	-	12700	-	12700	-	12700	-	11300	-	
	T_{out} [kgf·m]	-	-	1120	-	1240	-	1270	-	1290	-	1290	-	1290	-	1150	-	
	Pro[N]	-	-	67300	-	72600	-	82500	-	90200	-	102000	-	104000	-	104000	-	
	Pro[kgf]	-	-	6860	-	7400	-	8410	-	9190	-	10400	-	10600	-	10600	-	
6225	P_1 [kW]	-	-	74.7	-	61.7	-	45.1	-	33.2	-	23.8	-	17.2	-	11.1	-	CHH C-72 CHF C-77 CVW C-84
	T_{out} [N·m]	-	-	12900	-	14500	-	14800	-	15000	-	16000	-	15900	-	15100	-	
	T_{out} [kgf·m]	-	-	1310	-	1480	-	1510	-	1530	-	1630	-	1620	-	1540	-	
	Pro[N]	-	-	71100	-	77100	-	86900	-	95200	-	108000	-	118000	-	133000	-	
	Pro[kgf]	-	-	7250	-	7860	-	8860	-	9700	-	11000	-	12000	-	13600	-	
6235	P_1 [kW]	-	-	99.9	-	83.6	-	57.5	-	41.7	-	30.5	-	22.2	-	12.6	-	CHH C-72 CHF C-77 CVW C-84
	T_{out} [N·m]	-	-	17200	-	19600	-	18900	-	18900	-	20500	-	20500	-	17200	-	
	T_{out} [kgf·m]	-	-	1750	-	2000	-	1930	-	1930	-	2090	-	2090	-	1750	-	
	Pro[N]	-	-	88800	-	95300	-	108000	-	119000	-	133000	-	146000	-	166000	-	
	Pro[kgf]	-	-	9050	-	9710	-	11000	-	12100	-	13600	-	14900	-	16900	-	
6245	P_1 [kW]	-	-	117	-	112	-	78.5	-	56.9	-	38.4	-	28.0	-	16.6	-	CHH C-72 CHF C-77 CVW C-84
	T_{out} [N·m]	-	-	20200	-	26200	-	25800	-	25800	-	25800	-	25800	-	22600	-	
	T_{out} [kgf·m]	-	-	2060	-	2670	-	2630	-	2630	-	2630	-	2630	-	2300	-	
	Pro[N]	-	-	98600	-	106000	-	119000	-	131000	-	149000	-	163000	-	185000	-	
	Pro[kgf]	-	-	10100	-	10800	-	12100	-	13400	-	15200	-	16600	-	18900	-	
6255	P_1 [kW]	-	-	151	-	133	-	94.4	-	71.6	-	51.3	-	37.4	-	22.8	-	CHH C-72 CHF C-77 CVW C-84
	T_{out} [N·m]	-	-	25900	-	31200	-	31000	-	32500	-	34500	-	34500	-	31000	-	
	T_{out} [kgf·m]	-	-	2640	-	3180	-	3160	-	3310	-	3520	-	3520	-	3160	-	
	Pro[N]	-	-	121000	-	130000	-	146000	-	161000	-	182000	-	200000	-	226000	-	
	Pro[kgf]	-	-	12300	-	13300	-	14900	-	16400	-	18600	-	20400	-	23000	-	
6265	P_1 [kW]	-	-	175	-	175	-	140	-	101	-	68.4	-	49.8	-	32.3	-	CHH C-72 CHF C-77 CVW C-84
	T_{out} [N·m]	-	-	30100	-	41000	-	46000	-	46000	-	46000	-	46000	-	44000	-	
	T_{out} [kgf·m]	-	-	3070	-	4180	-	4690	-	4690	-	4690	-	4690	-	4490	-	
	Pro[N]	-	-	148000	-	158000	-	177000	-	197000	-	222000	-	243000	-	274000	-	
	Pro[kgf]	-	-	15100	-	16100	-	18000	-	20100	-	22600	-	24800	-	27900	-	
6275	P_1 [kW]	-	-	-	-	-	-	-	-	150	-	101	-	73.9	-	50.1	-	CHH C-72 CVW C-84
	T_{out} [N·m]	-	-	-	-	-	-	-	-	68200	-	68200	-	68200	-	68200	-	
	T_{out} [kgf·m]	-	-	-	-	-	-	-	-	6950	-	6950	-	6950	-	6950	-	
	Pro[N]	-	-	-	-	-	-	-	-	228000	-	248000	-	248000	-	245000	-	
	Pro[kgf]	-	-	-	-	-	-	-	23200	-	25300	-	25300	-	25000	-		

Note: 1. Allowable radial load Pro is the value at the midpoint of the output shaft. Refer to pages F-11~12 when radial load is off the midpoint of output shaft and for checking thrust load.
2. Refer to pages F-15~16 for allowable radial load for input shaft.

M E M O

A large grid of 20 columns and 40 rows for taking notes. The grid is composed of small squares, with the top-left corner containing the word 'MEMO' in bold capital letters.

REDUCERS
Selection Tables
Ratio xxx - xxx

Selection Tables 6000 Series Reducer

Single Reduction Ratio 6 ~ 119 Frame Size: 6060 ~ 6120

Input Speed	$n_1 = 720$ r/min	n_1 : Input Speed [r/min]	T_{out} : Allowable output torque [N·m, kgf·m]
		n_2 : Output Speed [r/min]	Pro: Allowable output shaft radial load [N, kgf]
		P_1 : Allowable input power [kW]	*Consult us for Pro of CNF and CHF type.

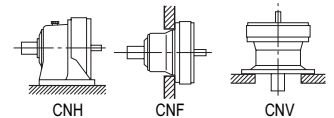

Selection Tables
Ratio 6 - 119
REDUCERS

Frame Size	n_2 [r/min] Ratio[Z]	120	90.0	65.5	55.4	48.0	42.4	34.3	28.8	24.8	20.6	16.7	14.1	12.2	10.1	8.28	6.05	Dim. Page	
		6	8	11	13	15	17	21	25	29	35	43	51	59	71	87	119		
6060	P_1 [kW]	0.200	0.200	0.173	0.147	0.127	0.112	0.091	0.076	0.066	0.054	0.044	-	-	-	-	-	-	
	T_{out} [N·m]	15.1	20.2	24.0	24.0	24.0	24.0	24.0	24.0	24.0	24.0	24.0	-	-	-	-	-	-	
	T_{out} [kgf·m]	1.54	2.06	2.45	2.45	2.45	2.45	2.45	2.45	2.45	2.45	2.45	-	-	-	-	-	-	
	Pro[N]	999	1050	1180	1180	1180	1180	1180	1180	1180	1180	1180	-	-	-	-	-	-	
	Pro[kgf]	102	107	120	120	120	120	120	120	120	120	120	-	-	-	-	-	-	
6065	P_1 [kW]	0.286	0.259	0.216	0.183	0.159	0.140	0.113	0.095	0.082	0.068	0.055	-	-	-	-	-	-	
	T_{out} [N·m]	21.6	26.1	30.0	30.0	30.0	30.0	30.0	30.0	30.0	30.0	30.0	-	-	-	-	-	-	
	T_{out} [kgf·m]	2.20	2.66	3.06	3.06	3.06	3.06	3.06	3.06	3.06	3.06	3.06	-	-	-	-	-	-	
	Pro[N]	987	985	1140	1180	1180	1180	1180	1180	1180	1180	1180	-	-	-	-	-	-	
	Pro[kgf]	101	100	116	120	120	120	120	120	120	120	120	-	-	-	-	-	-	
6070	P_1 [kW]	0.347	0.325	0.325	0.275	0.238	0.210	0.170	0.143	0.123	0.102	0.083	0.070	0.061	-	-	-	-	
	T_{out} [N·m]	26.2	32.8	45.0	45.0	45.0	45.0	45.0	45.0	45.0	45.0	45.0	45.0	45.0	-	-	-	-	
	T_{out} [kgf·m]	2.67	3.34	4.59	4.59	4.59	4.59	4.59	4.59	4.59	4.59	4.59	4.59	4.59	-	-	-	-	
	Pro[N]	1710	1770	1770	1770	1770	1770	1770	1770	1770	1770	1770	1770	1750	1770	-	-	-	
	Pro[kgf]	174	180	180	180	180	180	180	180	180	180	180	180	178	180	-	-	-	
6075	P_1 [kW]	0.376	0.325	0.344	0.322	0.317	0.280	0.227	0.190	0.164	0.136	0.111	0.089	0.077	-	-	-	-	
	T_{out} [N·m]	28.4	32.8	47.7	52.7	60.0	60.0	60.0	60.0	60.0	60.0	60.0	56.9	57.4	-	-	-	-	
	T_{out} [kgf·m]	2.90	3.34	4.86	5.37	6.12	6.12	6.12	6.12	6.12	6.12	6.12	5.80	5.85	-	-	-	-	
	Pro[N]	1700	1770	1770	1770	1770	1770	1770	1770	1770	1770	1770	1660	1580	-	-	-	-	
	Pro[kgf]	173	180	180	180	180	180	180	180	180	180	180	169	161	-	-	-	-	
6080	P_1 [kW]	0.592	0.592	0.577	0.488	0.423	0.373	0.292	0.254	0.219	0.181	0.148	0.124	0.108	0.089	0.073	-	-	
	T_{out} [N·m]	44.8	59.7	80.0	80.0	80.0	80.0	77.2	80.0	80.0	80.0	80.0	80.0	80.0	80.0	80.0	-	-	
	T_{out} [kgf·m]	4.57	6.09	8.15	8.15	8.15	8.15	7.87	8.15	8.15	8.15	8.15	8.15	8.15	8.15	8.15	-	-	
	Pro[N]	2380	2560	2560	2560	2560	2560	2560	2560	2500	2560	2560	2540	2480	2510	2460	2450	-	-
	Pro[kgf]	243	261	261	261	261	261	261	261	255	261	255	261	253	256	251	250	-	-
6085	P_1 [kW]	0.778	0.778	0.683	0.610	0.529	0.467	0.292	0.317	0.274	0.227	0.185	0.156	0.135	0.112	0.091	-	-	
	T_{out} [N·m]	58.8	78.4	94.7	100	100	100	77.2	100	100	100	100	100	100	100	100	-	-	
	T_{out} [kgf·m]	5.99	7.99	9.65	10.2	10.2	10.2	7.87	10.2	10.2	10.2	10.2	10.2	10.2	10.2	10.2	-	-	
	Pro[N]	2350	2530	2560	2560	2560	2560	2560	2360	2300	2420	2340	2290	2310	2260	2260	-	-	
	Pro[kgf]	240	258	261	261	261	261	261	241	234	247	239	233	235	230	230	-	-	
6090	P_1 [kW]	1.15	1.15	1.08	0.916	0.794	0.700	0.567	0.476	0.410	0.340	0.277	0.231	0.196	0.148	0.137	0.072	-	
	T_{out} [N·m]	86.7	116	150	150	150	150	150	150	150	150	150	149	146	132	150	108	-	
	T_{out} [kgf·m]	8.84	11.8	15.3	15.3	15.3	15.3	15.3	15.3	15.3	15.3	15.3	15.2	14.9	13.5	15.3	11.0	-	
	Pro[N]	3340	3340	3340	3340	3340	3340	3340	3280	3290	3300	3310	3280	3300	3310	3310	3310	-	-
	Pro[kgf]	340	340	340	340	340	340	340	334	335	336	337	334	336	337	337	337	-	-
6095	P_1 [kW]	1.52	1.52	1.24	1.19	1.06	0.934	0.756	0.588	0.547	0.453	0.369	0.239	0.196	0.148	0.154	0.072	-	
	T_{out} [N·m]	115	153	172	196	200	200	200	185	200	200	200	153	146	132	169	108	-	
	T_{out} [kgf·m]	11.7	15.6	17.5	20.0	20.4	20.4	20.4	18.9	20.4	20.4	20.4	15.6	14.9	13.5	17.2	11.0	-	
	Pro[N]	3340	3340	3340	3340	3340	3340	3340	3210	3200	3200	3220	3280	3300	3310	3280	3310	-	-
	Pro[kgf]	340	340	340	340	340	340	340	327	326	326	328	334	336	337	334	337	-	-
6100	P_1 [kW]	2.26	2.20	1.80	1.53	1.32	1.17	0.945	0.794	0.684	0.567	0.461	0.389	0.336	0.279	0.228	0.167	-	
	T_{out} [N·m]	171	222	250	250	250	250	250	250	250	250	250	250	250	250	250	250	-	
	T_{out} [kgf·m]	17.4	22.6	25.5	25.5	25.5	25.5	25.5	25.5	25.5	25.5	25.5	25.5	25.5	25.5	25.5	25.5	-	
	Pro[N]	5080	5400	5400	5400	5400	5400	5400	5400	5400	5400	5400	5400	5400	5400	5380	5400	5360	-
	Pro[kgf]	518	550	550	550	550	550	550	550	550	550	550	550	550	550	548	550	546	-
6105	P_1 [kW]	2.26	2.20	2.22	1.83	1.59	1.40	1.13	0.952	0.821	0.680	0.554	0.462	0.398	0.295	0.274	0.172	-	
	T_{out} [N·m]	171	222	308	300	300	300	300	300	300	300	300	297	296	264	300	258	-	
	T_{out} [kgf·m]	17.4	22.6	31.4	30.6	30.6	30.6	30.6	30.6	30.6	30.6	30.6	30.3	30.2	26.9	30.6	26.3	-	
	Pro[N]	5080	5400	5400	5400	5400	5400	5400	5400	5400	5400	5400	5310	5090	5370	4780	5350	-	
	Pro[kgf]	518	550	550	550	550	550	550	550	550	550	550	541	519	547	487	545	-	
6110	P_1 [kW]	2.56	3.55	2.60	2.20	1.90	1.68	1.36	1.14	0.985	0.816	0.664	0.560	0.484	0.402	0.328	-	-	
	T_{out} [N·m]	193	358	360	360	360	360	360	360	360	360	360	360	360	360	360	-	-	
	T_{out} [kgf·m]	19.7	36.5	36.7	36.7	36.7	36.7	36.7	36.7	36.7	36.7	36.7	36.7	36.7	36.7	36.7	-	-	
	Pro[N]	5760	6280	7260	7550	7610	7610	7610	7340	7200	7280	7590	7590	7610	7580	7600	-	-	
	Pro[kgf]	587	640	740	776	776	776	776	748	734	742	774	774	776	773	775	-	-	
6115	P_1 [kW]	2.56	3.92	3.03	2.56	2.22	1.96	1.59	1.33	1.15	0.952	0.775	0.654	0.565	0.469	0.383	-	-	
	T_{out} [N·m]	193	395	420	420	420	420	420	420	420	420	420	420	420	420	420	-	-	
	T_{out} [kgf·m]	19.7	40.3	42.8	42.8	42.8	42.8	42.8	42.8	42.8	42.8	42.8	42.8	42.8	42.8	42.8	-	-	
	Pro[N]	5760	6230	7180	7480	7610	7500	7460	7150	7010	7090	7370	7410	7430	7390	7410	-	-	
	Pro[kgf]	587	635	732	762	776	765	760	729	715	723	751	755	757	753	755	-	-	
6120	P_1 [kW]	4.85	4.72	3.79	3.20	2.78	2.43	1.97	1.67	1.42	1.19	0.969	0.817	0.706	0.587	0.479	-	-	
	T_{out} [N·m]	366	476	525	525	525	520	522	525	520	525	525	525	525	525	525	-	-	
	T_{out} [kgf·m]	37.3	48.5	53.5	53.5	53.5	53.0	53.2	53.5	53.0	53.5	53.5	53.5	53.5	53.5	53.5	-	-	
	Pro[N]	6380	7080	8100	8420	9090	9230	9810	9810	9810	9810	9810	9810	9810	9810	9810	9780	-	-
	Pro[kgf]	650	722	826	858	927	941	1000	1000	1000	1000	1000	1000	1000	1000	1000	997	-	-

Note: 1. Allowable radial load Pro is the value at the midpoint of the output shaft. Refer to pages F-11~12 when radial load is off the midpoint of output shaft and for checking thrust load.

2. Refer to pages F-15~16 for allowable radial load for input shaft.

Selection Tables 6000 Series Reducer

Single Reduction Ratio 6 ~ 119 Frame Size: 6205 ~ 6275

Input Speed	$n_1 = 720$ r/min	n_1 : Input Speed [r/min]	T_{out} : Allowable output torque [N·m, kgf·m]
		n_2 : Output Speed [r/min]	Pro: Allowable output shaft radial load [N, kgf]
		P_1 : Allowable input power [kW]	*Consult us for Pro of CNF and CHF type.

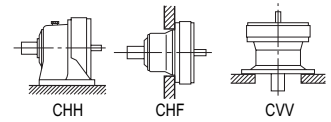

Selection Tables
Ratio 6 - 119
REDUCERS

Frame Size	n_2 [r/min] Ratio[Z]	120	90.0	65.5	55.4	48.0	42.4	34.3	28.8	24.8	20.6	16.7	14.1	12.2	10.1	8.28	6.05	Dim. Page
		6	8	11	13	15	17	21	25	29	35	43	51	59	71	87	119	
6205	P_1 [kW]	-	-	55.2	-	49.0	-	35.0	-	25.3	-	17.2	-	12.5	-	7.99	-	CHH C-72 CHF C-77 CVW C-84
	T_{out} [N·m]	-	-	7650	-	9270	-	9270	-	9230	-	9300	-	9300	-	8760	-	
	T_{out} [kgf·m]	-	-	780	-	945	-	945	-	941	-	948	-	948	-	893	-	
	Pro[N]	-	-	63000	-	67800	-	76300	-	83600	-	84100	-	84100	-	84100	-	
	Pro[kgf]	-	-	6420	-	6910	-	7780	-	8520	-	8570	-	8570	-	8570	-	
6215	P_1 [kW]	-	-	75.3	-	64.4	-	47.2	-	34.6	-	23.3	-	17.0	-	10.3	-	CHH C-72 CHF C-77 CVW C-84
	T_{out} [N·m]	-	-	10400	-	12200	-	12500	-	12700	-	12700	-	12700	-	11300	-	
	T_{out} [kgf·m]	-	-	1060	-	1240	-	1270	-	1290	-	1290	-	1290	-	1150	-	
	Pro[N]	-	-	63000	-	67900	-	77200	-	84400	-	95800	-	104000	-	104000	-	
	Pro[kgf]	-	-	6420	-	6920	-	7870	-	8600	-	9770	-	10600	-	10600	-	
6225	P_1 [kW]	-	-	88.1	-	76.6	-	55.9	-	41.2	-	29.5	-	21.4	-	13.7	-	CHH C-72 CHF C-77 CVW C-84
	T_{out} [N·m]	-	-	12200	-	14500	-	14800	-	15000	-	16000	-	15900	-	15100	-	
	T_{out} [kgf·m]	-	-	1240	-	1480	-	1510	-	1530	-	1630	-	1620	-	1540	-	
	Pro[N]	-	-	66600	-	72100	-	81200	-	89000	-	101000	-	110000	-	124000	-	
	Pro[kgf]	-	-	6790	-	7350	-	8280	-	9070	-	10300	-	11200	-	12600	-	
6235	P_1 [kW]	-	-	113	-	104	-	71.4	-	51.7	-	37.6	-	27.3	-	15.7	-	CHH C-72 CHF C-77 CVW C-84
	T_{out} [N·m]	-	-	15700	-	19600	-	18900	-	18900	-	20400	-	20300	-	17200	-	
	T_{out} [kgf·m]	-	-	1600	-	2000	-	1930	-	1930	-	2080	-	2070	-	1750	-	
	Pro[N]	-	-	83400	-	89000	-	101000	-	111000	-	125000	-	137000	-	155000	-	
	Pro[kgf]	-	-	8500	-	9070	-	10300	-	11300	-	12700	-	14000	-	15800	-	
6245	P_1 [kW]	-	-	132	-	132	-	97.5	-	70.6	-	47.6	-	34.7	-	20.7	-	CHH C-72 CHF C-77 CVW C-84
	T_{out} [N·m]	-	-	18300	-	24900	-	25800	-	25800	-	25800	-	25800	-	22600	-	
	T_{out} [kgf·m]	-	-	1870	-	2540	-	2630	-	2630	-	2630	-	2630	-	2300	-	
	Pro[N]	-	-	92600	-	98800	-	112000	-	123000	-	139000	-	152000	-	173000	-	
	Pro[kgf]	-	-	9440	-	10100	-	11400	-	12500	-	14200	-	15500	-	17600	-	
6255	P_1 [kW]	-	-	151	-	151	-	117	-	88.9	-	61.5	-	44.9	-	28.3	-	CHH C-72 CHF C-77 CVW C-84
	T_{out} [N·m]	-	-	20900	-	28500	-	31000	-	32500	-	33300	-	33400	-	31000	-	
	T_{out} [kgf·m]	-	-	2130	-	2910	-	3160	-	3310	-	3390	-	3400	-	3160	-	
	Pro[N]	-	-	114000	-	122000	-	136000	-	151000	-	170000	-	187000	-	211000	-	
	Pro[kgf]	-	-	11600	-	12400	-	13900	-	15400	-	17300	-	19100	-	21500	-	
6265	P_1 [kW]	-	-	175	-	175	-	172	-	126	-	84.9	-	61.9	-	40.2	-	CHH C-72 CHF C-77 CVW C-84
	T_{out} [N·m]	-	-	24200	-	33000	-	45400	-	46000	-	46000	-	46000	-	44000	-	
	T_{out} [kgf·m]	-	-	2470	-	3360	-	4630	-	4690	-	4690	-	4690	-	4490	-	
	Pro[N]	-	-	140000	-	149000	-	166000	-	184000	-	208000	-	228000	-	257000	-	
	Pro[kgf]	-	-	14300	-	15200	-	16900	-	18800	-	21200	-	23200	-	26200	-	
6275	P_1 [kW]	-	-	-	-	-	-	-	-	159	-	126	-	91.7	-	53.4	-	CHH C-72 CVW C-84
	T_{out} [N·m]	-	-	-	-	-	-	-	-	58100	-	68200	-	68200	-	58600	-	
	T_{out} [kgf·m]	-	-	-	-	-	-	-	-	5920	-	6950	-	6950	-	5970	-	
	Pro[N]	-	-	-	-	-	-	-	-	214000	-	248000	-	248000	-	240000	-	
	Pro[kgf]	-	-	-	-	-	-	-	21800	-	25300	-	25300	-	24500	-		

Note: 1. Allowable radial load Pro is the value at the midpoint of the output shaft. Refer to pages F-11~12 when radial load is off the midpoint of output shaft and for checking thrust load.
2. Refer to pages F-15~16 for allowable radial load for input shaft.

M E M O

A large grid of 20 columns and 40 rows for taking notes. The grid is composed of small squares, with the top-left corner containing the word 'MEMO' in bold capital letters.

REDUCERS
Selection Tables
Ratio xxx - xxx

Selection Tables 6000 Series Reducer

Single Reduction Ratio 6 ~ 119 Frame Size: 6060 ~ 6120

Input Speed	$n_1 = 870$ r/min	n_1 : Input Speed [r/min]										T_{out} : Allowable output torque [N·m, kgf·m]					Dim. Page					
		145	109	79.1	66.9	58.0	51.2	41.4	34.8	30.0	24.9	20.2	17.1	14.7	12.3	10.0		7.31	n_2 : Output Speed [r/min]	Pro: Allowable output shaft radial load [N, kgf]	P_i : Allowable input power [kW]	*Consult us for Pro of CNF and CHF type.
Frame Size	Ratio[Z]	6	8	11	13	15	17	21	25	29	35	43	51	59	71	87	119					
6060	P_i [kW]	0.200	0.200	0.200	0.177	0.153	0.135	0.110	0.092	0.079	0.066	0.054	-	-	-	-	-					
	T_{out} [N·m]	12.5	16.7	22.9	24.0	24.0	24.0	24.0	24.0	24.0	24.0	24.0	-	-	-	-	-					
	T_{out} [kgf·m]	1.27	1.70	2.33	2.45	2.45	2.45	2.45	2.45	2.45	2.45	2.45	-	-	-	-	-					
	Pro[N]	940	1070	1180	1180	1180	1180	1180	1180	1180	1180	1180	-	-	-	-	-					
	Pro[kgf]	95.8	109	120	120	120	120	120	120	120	120	120	-	-	-	-	-					
6065	P_i [kW]	0.286	0.286	0.262	0.221	0.192	0.169	0.137	0.115	0.099	0.082	0.067	-	-	-	-	-					
	T_{out} [N·m]	17.9	23.9	30.0	30.0	30.0	30.0	30.0	30.0	30.0	30.0	30.0	-	-	-	-	-					
	T_{out} [kgf·m]	1.82	2.44	3.06	3.06	3.06	3.06	3.06	3.06	3.06	3.06	3.06	-	-	-	-	-					
	Pro[N]	931	1010	1140	1180	1180	1180	1180	1180	1180	1180	1180	-	-	-	-	-					
	Pro[kgf]	94.9	103	116	120	120	120	120	120	120	120	120	-	-	-	-	-					
6070	P_i [kW]	0.347	0.347	0.347	0.332	0.288	0.254	0.205	0.173	0.149	0.123	0.100	0.085	0.073	-	-	-					
	T_{out} [N·m]	21.7	28.9	39.8	45.0	45.0	45.0	45.0	45.0	45.0	45.0	45.0	45.0	45.0	-	-	-					
	T_{out} [kgf·m]	2.21	2.95	4.06	4.59	4.59	4.59	4.59	4.59	4.59	4.59	4.59	4.59	4.59	-	-	-					
	Pro[N]	1610	1770	1770	1770	1770	1770	1770	1770	1770	1770	1770	1770	1750	1770	-	-					
	Pro[kgf]	164	180	180	180	180	180	180	180	180	180	180	180	178	180	-	-					
6075	P_i [kW]	0.407	0.361	0.397	0.372	0.369	0.338	0.274	0.224	0.198	0.164	0.134	0.107	0.092	-	-	-					
	T_{out} [N·m]	25.5	30.1	45.6	50.4	57.7	60.0	60.0	58.4	60.0	60.0	60.0	56.9	56.7	-	-	-					
	T_{out} [kgf·m]	2.60	3.07	4.65	5.14	5.88	6.12	6.12	5.95	6.12	6.12	6.12	5.80	5.78	-	-	-					
	Pro[N]	1600	1770	1770	1770	1770	1770	1770	1770	1770	1770	1770	1660	1580	1600	-	-					
	Pro[kgf]	163	180	180	180	180	180	180	180	180	180	180	169	161	163	-	-					
6080	P_i [kW]	0.592	0.592	0.592	0.590	0.511	0.451	0.353	0.307	0.265	0.219	0.178	0.150	0.130	0.108	0.088	-					
	T_{out} [N·m]	37.1	49.4	67.9	80.0	80.0	80.0	77.2	80.0	80.0	80.0	80.0	80.0	80.0	80.0	80.0	80.0					
	T_{out} [kgf·m]	3.78	5.04	6.92	8.15	8.15	8.15	7.87	8.15	8.15	8.15	8.15	8.15	8.15	8.15	8.15	8.15					
	Pro[N]	2240	2420	2560	2560	2560	2560	2560	2560	2500	2560	2540	2480	2510	2460	2450	-					
	Pro[kgf]	228	247	261	261	261	261	261	261	255	261	259	253	256	251	250	-					
6085	P_i [kW]	0.778	0.778	0.775	0.738	0.639	0.564	0.353	0.384	0.331	0.274	0.223	0.188	0.163	0.135	0.110	-					
	T_{out} [N·m]	48.7	64.9	88.9	100	100	100	77.2	100	100	100	100	100	100	100	100	100					
	T_{out} [kgf·m]	4.96	6.62	9.06	10.2	10.2	10.2	7.87	10.2	10.2	10.2	10.2	10.2	10.2	10.2	10.2	10.2					
	Pro[N]	2220	2390	2560	2560	2560	2560	2560	2360	2300	2420	2340	2290	2310	2260	2260	2260					
	Pro[kgf]	226	244	261	261	261	261	261	241	234	247	239	233	235	230	230	-					
6090	P_i [kW]	1.15	1.15	1.15	1.11	0.959	0.846	0.685	0.575	0.496	0.411	0.335	0.280	0.237	0.179	0.165	0.087					
	T_{out} [N·m]	71.7	95.6	131	150	150	150	150	150	150	150	150	149	146	132	150	108					
	T_{out} [kgf·m]	7.31	9.75	13.4	15.3	15.3	15.3	15.3	15.3	15.3	15.3	15.3	15.2	14.9	13.5	15.3	11.0					
	Pro[N]	3290	3340	3340	3340	3340	3340	3340	3280	3290	3300	3310	3280	3300	3310	3310	3310					
	Pro[kgf]	335	340	340	340	340	340	340	334	335	336	337	334	336	337	337	337					
6095	P_i [kW]	1.52	1.52	1.43	1.38	1.28	1.13	0.913	0.680	0.637	0.548	0.430	0.288	0.237	0.179	0.178	0.087					
	T_{out} [N·m]	94.8	126	164	187	200	200	200	177	193	200	193	153	146	132	162	108					
	T_{out} [kgf·m]	9.66	12.8	16.7	19.1	20.4	20.4	20.4	18.0	19.7	20.4	19.7	15.6	14.9	13.5	16.5	11.0					
	Pro[N]	3240	3340	3340	3340	3340	3340	3340	3230	3210	3200	3230	3280	3300	3310	3290	3310					
	Pro[kgf]	330	340	340	340	340	340	340	329	327	326	329	334	336	337	335	337					
6100	P_i [kW]	2.35	2.35	2.18	1.84	1.60	1.41	1.14	0.959	0.827	0.685	0.558	0.470	0.406	0.338	0.276	0.201					
	T_{out} [N·m]	147	196	250	250	250	250	250	250	250	250	250	250	250	250	250	250					
	T_{out} [kgf·m]	15.0	20.0	25.5	25.5	25.5	25.5	25.5	25.5	25.5	25.5	25.5	25.5	25.5	25.5	25.5	25.5					
	Pro[N]	4790	5320	5400	5400	5400	5400	5400	5400	5400	5400	5400	5400	5400	5400	5380	5400					
	Pro[kgf]	488	542	550	550	550	550	550	550	550	550	550	550	550	550	548	550					
6105	P_i [kW]	2.73	2.54	2.61	2.21	1.92	1.69	1.37	1.15	0.992	0.822	0.669	0.558	0.481	0.357	0.331	0.208					
	T_{out} [N·m]	171	212	300	300	300	300	300	300	300	300	300	297	296	264	300	258					
	T_{out} [kgf·m]	17.4	21.6	30.6	30.6	30.6	30.6	30.6	30.6	30.6	30.6	30.6	30.3	30.2	26.9	30.6	26.3					
	Pro[N]	4760	5300	5400	5400	5400	5400	5400	5400	5400	5400	5400	5310	5090	5370	4780	5350					
	Pro[kgf]	485	540	550	550	550	550	550	550	550	550	550	541	519	547	487	545					
6110	P_i [kW]	3.09	3.55	3.14	2.66	2.30	2.03	1.64	1.38	1.19	0.986	0.803	0.677	0.585	0.486	0.397	-					
	T_{out} [N·m]	193	296	360	360	360	360	360	360	360	360	360	360	360	360	360	-					
	T_{out} [kgf·m]	19.7	30.2	36.7	36.7	36.7	36.7	36.7	36.7	36.7	36.7	36.7	36.7	36.7	36.7	36.7	-					
	Pro[N]	5400	5940	6790	7060	7570	7610	7610	7340	7200	7280	7590	7590	7610	7580	7600	-					
	Pro[kgf]	550	606	692	720	772	776	776	748	734	742	774	774	776	773	775	-					
6115	P_i [kW]	3.09	3.92	3.66	3.10	2.69	2.37	1.92	1.61	1.39	1.15	0.937	0.790	0.683	0.567	0.463	-					
	T_{out} [N·m]	193	327	420	420	420	420	420	420	420	420	420	420	420	420	420	-					
	T_{out} [kgf·m]	19.7	33.3	42.8	42.8	42.8	42.8	42.8	42.8	42.8	42.8	42.8	42.8	42.8	42.8	42.8	-					
	Pro[N]	5400	5910	6710	6990	7500	7500	7460	7150	7010	7090	7370	7410	7430	7390	7410	-					
	Pro[kgf]	550	602	684	713	765	765	760	729	715	723	751	755	757	753	755	-					
6120	P_i [kW]	5.07	5.07	4.58	3.87	3.36	2.93	2.38	2.01	1.72	1.44	1.17	0.987	0.853	0.709	0.579	-					
	T_{out} [N·m]	317	423	525	525	525	520	522	525	520	525	525	525	525	525	525	-					
	T_{out} [kgf·m]	32.3	43.1	53.5	53.5	53.5	53.0	53.2	53.5	53.0	53.5	53.5	53.5	53.5	53.5	53.5	-					
	Pro[N]	6020	6680	7570	7870	8510	8640	9540	9810	9810	9810	9810	9810	9810	9810	9780	-					
	Pro[kgf]	614	681	772	802	867	881	972	1000	1000	1000	1000	1000	1000	1000	997	-					
Frame Size	Ratio[Z]	6	8	11	1																	

Selection Tables 6000 Series Reducer

Single Reduction Ratio 6 ~ 119 Frame Size: 6125 ~ 6195

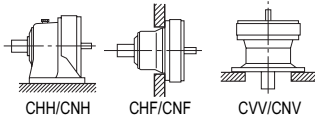

n_1 : Input Speed [r/min] T_{out} : Allowable output torque [N·m, kgf·m]
 n_2 : Output Speed [r/min] Pro: Allowable output shaft radial load [N, kgf]
 P_1 : Allowable input power [kW] *Consult us for Pro of CNF and CHF type.

Input Speed $n_1 = 870$ r/min

Frame Size	n_2 [r/min] Ratio[Z]	145	109	79.1	66.9	58.0	51.2	41.4	34.8	30.0	24.9	20.2	17.1	14.7	12.3	10.0	7.31	Dim. Page	
6125	P_1 [kW]	5.84	5.45	4.73	4.27	4.03	3.55	2.88	2.42	2.08	1.73	1.40	1.18	1.02	0.770	0.694	-	CNH C-71	
	T_{out} [N·m]	366	455	542	579	630	630	630	630	630	630	630	630	630	570	630	-	CNF C-76	
	T_{out} [kgf·m]	37.3	46.4	55.2	59.0	64.2	64.2	64.2	64.2	64.2	64.2	64.2	64.2	64.2	58.1	64.2	-	CNV C-82	
	Pro[N]	5960	6640	7550	7820	8400	8540	9440	9810	9810	9810	9810	9810	9810	9810	9810	9560	-	
	Pro[kgf]	608	677	770	797	856	871	962	1000	1000	1000	1000	1000	1000	1000	1000	975	-	
6130	P_1 [kW]	8.31	8.17	6.80	5.75	4.99	4.40	3.56	2.99	2.58	2.14	1.74	1.65	1.43	1.19	0.935	-	CNH C-72	
	T_{out} [N·m]	520	682	780	780	780	780	780	780	780	780	780	880	880	880	848	-	CHF C-77	
	T_{out} [kgf·m]	53.0	69.5	79.5	79.5	79.5	79.5	79.5	79.5	79.5	79.5	79.5	89.7	89.7	89.7	86.4	-	CVV C-83	
	Pro[N]	6890	7660	8830	9270	9520	10300	11000	11500	12200	12900	13900	14500	14700	14700	14700	14700	-	
	Pro[kgf]	702	781	900	945	970	1050	1120	1170	1240	1310	1420	1480	1500	1500	1500	1500	-	
6135	P_1 [kW]	9.10	8.40	8.19	6.92	6.01	5.30	4.29	3.45	3.11	2.58	2.10	1.72	1.65	1.37	1.08	-	CNH C-72	
	T_{out} [N·m]	569	701	940	938	940	940	940	900	940	940	940	940	917	1010	1010	979	-	CHF C-77
	T_{out} [kgf·m]	58.0	71.5	95.8	95.6	95.8	95.8	95.8	91.7	95.8	95.8	95.8	93.5	103	103	99.8	-	CVV C-83	
	Pro[N]	6830	7640	8680	9150	9400	10100	10900	11500	12100	12800	13800	14400	14700	14700	14700	14700	-	
	Pro[kgf]	696	779	885	933	958	1030	1110	1170	1230	1300	1410	1470	1500	1500	1500	1500	-	
6140	P_1 [kW]	11.2	10.6	10.7	9.04	7.83	6.91	5.59	4.70	4.05	3.36	2.73	2.30	1.99	1.65	1.35	-	CNH C-72	
	T_{out} [N·m]	698	887	1230	1230	1230	1230	1230	1230	1230	1230	1230	1230	1230	1230	1230	1230	-	CHF C-77
	T_{out} [kgf·m]	71.2	90.4	125	125	125	125	125	125	125	125	125	125	125	125	125	125	-	CVV C-83
	Pro[N]	10700	11900	13300	13600	14300	15000	16000	16000	16000	16000	16000	16000	16000	16000	16000	16000	-	
	Pro[kgf]	1090	1210	1360	1390	1460	1530	1630	1630	1630	1630	1630	1630	1630	1630	1630	1630	-	
6145	P_1 [kW]	11.2	10.6	11.0	10.1	8.68	7.73	6.11	5.26	4.53	3.75	3.06	2.50	2.15	1.77	1.38	-	CNH C-72	
	T_{out} [N·m]	698	887	1260	1370	1360	1370	1340	1370	1370	1370	1370	1370	1330	1320	1310	1250	-	CHF C-77
	T_{out} [kgf·m]	71.2	90.4	128	140	139	140	137	140	140	140	140	136	135	134	127	-	CVV C-83	
	Pro[N]	10700	11900	13300	13600	14200	14900	16000	16000	15800	16000	15700	15900	16000	16000	16000	16000	-	
	Pro[kgf]	1090	1210	1360	1390	1450	1520	1630	1630	1610	1630	1600	1620	1630	1630	1630	1630	-	
6160	P_1 [kW]	20.3	19.7	15.3	12.9	11.2	9.90	8.01	6.73	5.80	4.81	3.87	3.30	2.85	2.37	1.93	-	CNH C-72	
	T_{out} [N·m]	1270	1640	1760	1760	1760	1760	1760	1760	1760	1760	1740	1760	1760	1760	1760	-	CHF C-77	
	T_{out} [kgf·m]	129	167	179	179	179	179	179	179	179	179	177	179	179	179	179	-	CVV C-84	
	Pro[N]	11700	13000	14900	15800	16800	17400	18800	19800	20800	22100	22100	22100	22100	22100	22100	22100	-	
	Pro[kgf]	1190	1330	1520	1610	1710	1770	1920	2020	2120	2250	2250	2250	2250	2250	2250	2250	-	
6165	P_1 [kW]	21.2	20.6	18.3	15.5	13.4	11.8	9.59	8.06	6.94	5.75	4.68	3.95	3.41	2.84	2.26	-	CNH C-72	
	T_{out} [N·m]	1320	1720	2100	2100	2100	2100	2100	2100	2100	2100	2100	2100	2100	2100	2050	-	CHF C-77	
	T_{out} [kgf·m]	135	175	214	214	214	214	214	214	214	214	214	214	214	214	209	-	CVV C-84	
	Pro[N]	11600	12900	14700	15500	16600	17200	18600	19600	20500	21900	22100	22100	22100	22100	21800	-		
	Pro[kgf]	1180	1310	1500	1580	1690	1750	1900	2000	2090	2230	2250	2250	2250	2250	2220	-		
6170	P_1 [kW]	27.6	27.6	22.1	18.6	16.2	14.3	11.6	9.70	8.37	6.93	5.64	4.76	4.11	3.42	2.79	-	CNH C-72	
	T_{out} [N·m]	1730	2300	2530	2530	2530	2530	2530	2530	2530	2530	2530	2530	2530	2530	2530	-	CHF C-77	
	T_{out} [kgf·m]	176	234	258	258	258	258	258	258	258	258	258	258	258	258	258	-	CVV C-84	
	Pro[N]	13100	14400	16700	17500	18500	19400	21200	22100	23400	24900	26600	27900	29400	29500	29500	-		
	Pro[kgf]	1340	1470	1700	1780	1890	1980	2160	2250	2390	2540	2710	2840	3000	3010	3010	-		
6175	P_1 [kW]	29.7	30.1	27.5	23.2	20.1	17.8	14.4	12.1	10.4	8.63	7.02	5.92	5.12	4.25	3.47	-	CNH C-72	
	T_{out} [N·m]	1860	2510	3150	3150	3150	3150	3150	3150	3150	3150	3150	3150	3150	3150	3150	-	CHF C-77	
	T_{out} [kgf·m]	190	256	321	321	321	321	321	321	321	321	321	321	321	321	321	-	CVV C-84	
	Pro[N]	13000	14200	16300	17100	18000	19000	20800	21800	23000	24600	26300	27600	29100	29500	29500	-		
	Pro[kgf]	1330	1450	1660	1740	1830	1940	2120	2220	2340	2510	2680	2810	2970	3010	3010	-		
6180	P_1 [kW]	-	-	35.2	29.9	26.0	22.9	18.5	15.5	13.4	11.1	9.05	7.62	6.58	5.47	4.48	-	CNH C-72	
	T_{out} [N·m]	-	-	4040	4060	4060	4060	4050	4050	4050	4050	4060	4050	4050	4050	4060	-	CHF C-77	
	T_{out} [kgf·m]	-	-	412	414	414	414	413	413	413	413	414	413	413	413	414	-	CVV C-84	
	Pro[N]	-	-	22100	23100	24500	26000	28200	29500	31000	33200	35800	37200	39000	41600	41700	-		
	Pro[kgf]	-	-	2250	2350	2500	2650	2870	3010	3160	3380	3650	3790	3980	4240	4250	-		
6185	P_1 [kW]	-	-	39.0	36.2	27.2	25.8	22.8	19.2	16.5	13.7	11.2	9.40	8.13	6.10	5.51	-	CNH C-72	
	T_{out} [N·m]	-	-	4470	4900	4250	4580	5000	5000	5000	5000	5000	5000	5000	4510	5000	-	CHF C-77	
	T_{out} [kgf·m]	-	-	456	499	433	467	510	510	510	510	510	510	510	460	510	-	CVV C-84	
	Pro[N]	-	-	21900	22700	24400	25700	27900	29100	30600	32900	35400	36900	38700	41500	41700	-		
	Pro[kgf]	-	-	2230	2310	2490	2620	2840	2970	3120	3350	3610	3760	3940	4230	4250	-		
6190	P_1 [kW]	-	-	41.0	41.0	40.8	36.0	29.1	24.5	21.1	17.5	14.2	12.0	10.4	8.62	7.03	-	CNH C-72	
	T_{out} [N·m]	-	-	4700	5560	6380	6380	6380	6380	6380	6380	6380	6380	6380	6380	6380	-	CHF C-77	
	T_{out} [kgf·m]	-	-	479	567	650	650	650	650	650	650	650	650	650	650	650	-	CVV C-84	
	Pro[N]	-	-	31400	32400	33900	36000	39200	41200	43400	46000	49700	52000	54600	58100	58900	-		
	Pro[kgf]	-	-	3200	3300	3460	3670	4000	4200	4420	4690	5070	5300	5570	5920	6000	-		
6195	P_1 [kW]	-	-	48.1	48.1	45.3	44.9	36.3	30.5	26.3	21.8	17.8	15.0	12.9	10.8	8.77	-	CNH C-72	
	T_{out} [N·m]	-	-	5520	6520	7090	7960	7960	7960	7960	7960	7960	7960	7960	7960	7960	-	CHF C-77	
	T_{out} [kgf·m]	-	-	563	665	723	811	811											

Selection Tables 6000 Series Reducer

Single Reduction Ratio 6 ~ 119 Frame Size: 6205 ~ 6275

Input Speed	$n_1 = 870$ r/min	n_1 : Input Speed [r/min]	T_{out} : Allowable output torque [N·m, kgf·m]
		n_2 : Output Speed [r/min]	Pro: Allowable output shaft radial load [N, kgf]
		P_i : Allowable input power [kW]	*Consult us for Pro of CNF and CHF type.

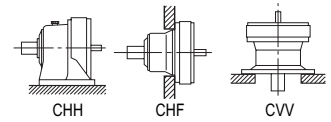

Selection Tables
Ratio 6 - 119
REDUCERS

Frame Size	n_2 [r/min] Ratio[Z]	145	109	79.1	66.9	58.0	51.2	41.4	34.8	30.0	24.9	20.2	17.1	14.7	12.3	10.0	7.31	Dim. Page
		6	8	11	13	15	17	21	25	29	35	43	51	59	71	87	119	
6205	P_i [kW]	-	-	59.7	-	58.3	-	42.4	-	30.5	-	20.7	-	15.1	-	9.65	-	CHH C-72 CHF C-77 CVW C-84
	T_{out} [N·m]	-	-	6850	-	9130	-	9270	-	9230	-	9300	-	9300	-	8760	-	
	T_{out} [kgf·m]	-	-	698	-	931	-	945	-	941	-	948	-	948	-	893	-	
	Pro[N]	-	-	59700	-	63900	-	72000	-	78800	-	84100	-	84100	-	84100	-	
	Pro[kgf]	-	-	6090	-	6510	-	7340	-	8030	-	8570	-	8570	-	8570	-	
6215	P_i [kW]	-	-	75.3	-	75.3	-	57.1	-	41.8	-	28.2	-	20.6	-	12.4	-	CHH C-72 CHF C-77 CVW C-84
	T_{out} [N·m]	-	-	8640	-	11800	-	12500	-	12700	-	12700	-	12700	-	11300	-	
	T_{out} [kgf·m]	-	-	881	-	1200	-	1270	-	1290	-	1290	-	1290	-	1150	-	
	Pro[N]	-	-	59900	-	64000	-	72700	-	79500	-	90300	-	98700	-	104000	-	
	Pro[kgf]	-	-	6110	-	6520	-	7410	-	8100	-	9200	-	10100	-	10600	-	
6225	P_i [kW]	-	-	99.5	-	92.6	-	67.6	-	49.7	-	35.7	-	25.8	-	16.6	-	CHH C-72 CHF C-77 CVW C-84
	T_{out} [N·m]	-	-	11400	-	14500	-	14800	-	15000	-	16000	-	15900	-	15100	-	
	T_{out} [kgf·m]	-	-	1160	-	1480	-	1510	-	1530	-	1630	-	1620	-	1540	-	
	Pro[N]	-	-	63000	-	67900	-	76500	-	83900	-	95100	-	104000	-	117000	-	
	Pro[kgf]	-	-	6420	-	6920	-	7800	-	8550	-	9690	-	10600	-	11900	-	
6235	P_i [kW]	-	-	113	-	113	-	86.3	-	62.5	-	43.4	-	31.6	-	18.9	-	CHH C-72 CHF C-77 CVW C-84
	T_{out} [N·m]	-	-	13000	-	17700	-	18900	-	18900	-	19500	-	19400	-	17200	-	
	T_{out} [kgf·m]	-	-	1330	-	1800	-	1930	-	1930	-	1990	-	1980	-	1750	-	
	Pro[N]	-	-	79200	-	84300	-	95400	-	105000	-	118000	-	129000	-	146000	-	
	Pro[kgf]	-	-	8070	-	8590	-	9720	-	10700	-	12000	-	13100	-	14900	-	
6245	P_i [kW]	-	-	132	-	132	-	118	-	85.3	-	57.5	-	41.9	-	25.0	-	CHH C-72 CHF C-77 CVW C-84
	T_{out} [N·m]	-	-	15100	-	20600	-	25800	-	25800	-	25800	-	25800	-	22600	-	
	T_{out} [kgf·m]	-	-	1540	-	2100	-	2630	-	2630	-	2630	-	2630	-	2300	-	
	Pro[N]	-	-	88000	-	94000	-	105000	-	116000	-	131000	-	144000	-	163000	-	
	Pro[kgf]	-	-	8970	-	9580	-	10700	-	11800	-	13400	-	14700	-	16600	-	
6255	P_i [kW]	-	-	151	-	151	-	142	-	107	-	71.1	-	51.9	-	34.2	-	CHH C-72 CHF C-77 CVW C-84
	T_{out} [N·m]	-	-	17300	-	23600	-	31000	-	32500	-	31900	-	31900	-	31000	-	
	T_{out} [kgf·m]	-	-	1760	-	2410	-	3160	-	3310	-	3250	-	3250	-	3160	-	
	Pro[N]	-	-	108000	-	116000	-	128000	-	142000	-	161000	-	176000	-	199000	-	
	Pro[kgf]	-	-	11000	-	11800	-	13000	-	14500	-	16400	-	17900	-	20300	-	
6265	P_i [kW]	-	-	175	-	175	-	172	-	152	-	103	-	74.8	-	48.5	-	CHH C-72 CHF C-77 CVW C-84
	T_{out} [N·m]	-	-	20100	-	27300	-	37600	-	46000	-	46000	-	46000	-	44000	-	
	T_{out} [kgf·m]	-	-	2050	-	2780	-	3830	-	4690	-	4690	-	4690	-	4490	-	
	Pro[N]	-	-	132000	-	141000	-	158000	-	174000	-	196000	-	215000	-	242000	-	
	Pro[kgf]	-	-	13500	-	14400	-	16100	-	17700	-	20000	-	21900	-	24700	-	
6275	P_i [kW]	-	-	-	-	-	-	-	-	159	-	151	-	111	-	53.4	-	CHH C-72 CVW C-84
	T_{out} [N·m]	-	-	-	-	-	-	-	-	48100	-	67600	-	68200	-	48500	-	
	T_{out} [kgf·m]	-	-	-	-	-	-	-	-	4900	-	6890	-	6950	-	4940	-	
	Pro[N]	-	-	-	-	-	-	-	-	203000	-	248000	-	248000	-	227000	-	
	Pro[kgf]	-	-	-	-	-	-	-	20700	-	25300	-	25300	-	23100	-		
Frame Size	n_2 [r/min]	145	109	79.1	66.9	58.0	51.2	41.4	34.8	30.0	24.9	20.2	17.1	14.7	12.3	10.0	7.31	Dim. Page

Note: 1. Allowable radial load Pro is the value at the midpoint of the output shaft. Refer to pages F-11~12 when radial load is off the midpoint of output shaft and for checking thrust load.
2. Refer to pages F-15~16 for allowable radial load for input shaft.

M E M O

A large grid of 20 columns and 40 rows for taking notes. The grid is composed of small squares, with the top-left corner containing the word 'MEMO' in bold capital letters.

REDUCERS
Selection Tables
Ratio xxx - xxx

Selection Tables 6000 Series Reducer

Single Reduction Ratio 6 ~ 119 Frame Size: 6125 ~ 6195

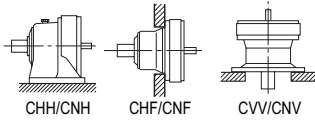

n_1 : Input Speed [r/min] T_{out} : Allowable output torque [N·m, kgf·m]
 n_2 : Output Speed [r/min] Pro: Allowable output shaft radial load [N, kgf]
 P_i : Allowable input power [kW] *Consult us for Pro of CNF and CHF type.

Input Speed $n_1 = 980$ r/min

Frame Size	n_2 [r/min] Ratio[Z]	163	123	89.1	75.4	65.3	57.6	46.7	39.2	33.8	28.0	22.8	19.2	16.6	13.8	11.3	8.24	Dim. Page
		6	8	11	13	15	17	21	25	29	35	43	51	59	71	87	119	
6125	P_i [kW]	6.40	5.97	5.18	4.68	4.54	4.00	3.24	2.72	2.35	1.94	1.58	1.33	1.15	0.843	0.761	-	- - - - -
	T_{out} [N·m]	355	442	527	563	630	630	630	630	630	630	630	630	630	554	613	-	
	T_{out} [kgf·m]	36.2	45.1	53.7	57.4	64.2	64.2	64.2	64.2	64.2	64.2	64.2	64.2	64.2	56.5	62.5	-	
	Pro[N]	5730	6380	7250	7510	8050	8180	9050	9540	9810	9810	9810	9810	9810	9810	9590	-	
	Pro[kgf]	584	650	739	766	821	834	923	972	1000	1000	1000	1000	1000	1000	978	-	
6130	P_i [kW]	9.10	8.95	7.66	6.48	5.62	4.96	4.01	3.37	2.91	2.41	1.96	1.81	1.57	1.30	1.05	-	- - - - -
	T_{out} [N·m]	505	663	780	780	780	780	780	780	780	780	780	855	855	855	848	-	
	T_{out} [kgf·m]	51.5	67.6	79.5	79.5	79.5	79.5	79.5	79.5	79.5	79.5	79.5	87.2	87.2	87.2	86.4	-	
	Pro[N]	6620	7350	8460	8890	9130	9840	10600	11100	11700	12400	13300	13900	14600	14700	14700	-	
	Pro[kgf]	675	749	862	906	931	1000	1080	1130	1190	1260	1360	1420	1490	1500	1500	-	
6135	P_i [kW]	9.96	9.20	9.23	7.58	6.77	5.97	4.84	3.89	3.50	2.90	2.36	1.89	1.81	1.50	1.22	-	- - - - -
	T_{out} [N·m]	553	682	940	912	940	940	940	900	940	940	940	892	987	987	979	-	
	T_{out} [kgf·m]	56.4	69.5	95.8	93.0	95.8	95.8	95.8	91.7	95.8	95.8	95.8	90.9	101	101	99.8	-	
	Pro[N]	6560	7330	8310	8780	9010	9720	10500	11000	11600	12200	13200	13900	14500	14700	14700	-	
	Pro[kgf]	669	747	847	895	918	991	1070	1120	1180	1240	1350	1420	1480	1500	1500	-	
6140	P_i [kW]	12.2	11.6	12.0	10.2	8.82	7.78	6.30	5.29	4.56	3.78	3.08	2.59	2.24	1.86	1.52	-	- - - - -
	T_{out} [N·m]	678	863	1230	1230	1230	1230	1230	1230	1230	1230	1230	1230	1230	1230	1230	-	
	T_{out} [kgf·m]	69.1	88.0	125	125	125	125	125	125	125	125	125	125	125	125	125	-	
	Pro[N]	10300	11400	12800	13100	13800	14400	15500	16000	16000	16000	16000	16000	16000	16000	16000	-	
	Pro[kgf]	1050	1160	1300	1340	1410	1470	1580	1630	1630	1630	1630	1630	1630	1630	1630	-	
6145	P_i [kW]	12.2	11.6	12.1	11.4	9.78	8.71	6.88	5.92	5.10	4.23	3.44	2.74	2.36	1.94	1.55	-	- - - - -
	T_{out} [N·m]	678	863	1230	1370	1360	1370	1340	1370	1370	1370	1370	1290	1290	1280	1250	-	
	T_{out} [kgf·m]	69.1	88.0	125	140	139	140	137	140	140	140	140	131	131	130	127	-	
	Pro[N]	10300	11400	12800	13100	13700	14400	15400	16000	15800	16000	15700	15900	16000	16000	16000	-	
	Pro[kgf]	1050	1160	1300	1340	1400	1470	1570	1630	1610	1630	1600	1620	1630	1630	1630	-	
6160	P_i [kW]	20.3	19.7	17.2	14.6	12.6	11.2	9.03	7.58	6.54	5.42	4.36	3.72	3.21	2.67	2.18	-	- - - - -
	T_{out} [N·m]	1130	1460	1760	1760	1760	1760	1760	1760	1760	1760	1740	1760	1760	1760	1760	-	
	T_{out} [kgf·m]	115	149	179	179	179	179	179	179	179	179	177	179	179	179	179	-	
	Pro[N]	11300	12600	14300	15100	16100	16700	18100	19000	19900	21200	22100	22100	22100	22100	22100	-	
	Pro[kgf]	1150	1280	1460	1540	1640	1700	1850	1940	2030	2160	2250	2250	2250	2250	2250	-	
6165	P_i [kW]	23.8	22.5	20.6	17.4	15.1	13.3	10.8	9.07	7.82	6.48	5.28	4.45	3.84	3.19	2.55	-	- - - - -
	T_{out} [N·m]	1320	1670	2100	2100	2100	2100	2100	2100	2100	2100	2100	2100	2100	2100	2050	-	
	T_{out} [kgf·m]	135	170	214	214	214	214	214	214	214	214	214	214	214	214	209	-	
	Pro[N]	11100	12400	14100	14900	15900	16500	17800	18800	19700	21000	22100	22100	22100	22100	21800	-	
	Pro[kgf]	1130	1260	1440	1520	1620	1680	1810	1920	2010	2140	2250	2250	2250	2250	2220	-	
6170	P_i [kW]	27.6	27.6	24.8	21.0	18.2	16.1	13.0	10.9	9.42	7.81	6.36	5.36	4.63	3.85	3.14	-	- - - - -
	T_{out} [N·m]	1530	2040	2530	2530	2530	2530	2530	2530	2530	2530	2530	2530	2530	2530	2530	-	
	T_{out} [kgf·m]	156	208	258	258	258	258	258	258	258	258	258	258	258	258	258	-	
	Pro[N]	12700	13900	16000	16800	17700	18600	20300	21200	22400	23900	25600	26800	28200	29500	29500	-	
	Pro[kgf]	1290	1420	1630	1710	1800	1900	2070	2160	2280	2440	2610	2730	2870	3010	3010	-	
6175	P_i [kW]	30.1	30.1	30.1	26.2	22.3	20.0	16.2	13.6	11.7	9.72	7.91	6.67	5.77	4.79	3.91	-	- - - - -
	T_{out} [N·m]	1670	2230	3070	3150	3100	3150	3150	3150	3150	3150	3150	3150	3150	3150	3150	-	
	T_{out} [kgf·m]	170	227	313	321	316	321	321	321	321	321	321	321	321	321	321	-	
	Pro[N]	12600	13800	15600	16400	17300	18200	20000	20800	22100	23600	25200	26500	27900	29500	29500	-	
	Pro[kgf]	1280	1410	1590	1670	1760	1860	2040	2120	2250	2410	2570	2700	2840	3010	3010	-	
6180	P_i [kW]	-	-	35.2	33.7	29.2	25.8	20.8	17.5	15.1	12.5	10.2	8.58	7.42	6.16	5.04	-	- - - - -
	T_{out} [N·m]	-	-	3580	4060	4060	4060	4050	4050	4050	4050	4060	4050	4050	4050	4060	-	
	T_{out} [kgf·m]	-	-	365	414	414	414	413	413	413	413	414	413	413	413	414	-	
	Pro[N]	-	-	21400	22200	23400	24900	27100	28300	29700	31900	34300	35700	37400	39900	41700	-	
	Pro[kgf]	-	-	2180	2260	2390	2540	2760	2880	3030	3250	3500	3640	3810	4070	4250	-	
6185	P_i [kW]	-	-	39.0	39.0	29.8	28.3	25.7	21.6	18.6	15.4	12.6	10.6	9.15	6.87	6.21	-	- - - - -
	T_{out} [N·m]	-	-	3970	4690	4130	4450	5000	5000	5000	5000	5000	5000	5000	4510	5000	-	
	T_{out} [kgf·m]	-	-	405	478	421	454	510	510	510	510	510	510	510	460	510	-	
	Pro[N]	-	-	21200	21900	23400	24700	26700	27900	29300	31500	33900	35400	37100	39800	41700	-	
	Pro[kgf]	-	-	2160	2230	2390	2520	2720	2840	2990	3210	3460	3610	3780	4060	4250	-	
6190	P_i [kW]	-	-	41.0	41.0	41.0	40.5	32.8	27.6	23.8	19.7	16.0	13.5	11.7	9.71	7.92	-	- - - - -
	T_{out} [N·m]	-	-	4180	4930	5690	6380	6380	6380	6380	6380	6380	6380	6380	6380	6380	-	
	T_{out} [kgf·m]	-	-	426	503	580	650	650	650	650	650	650	650	650	650	650	-	
	Pro[N]	-	-	30300	31300	32700	34500	37600	39500	41600	44100	47700	49900	52400	55800	58900	-	
	Pro[kgf]	-	-	3090	3190	3330	3520	3830	4030	4240	4500	4860	5090	5340	5690	6000	-	
6195	P_i [kW]	-	-	48.1	48.1	48.1	48.1	40.9	34.4	29.6	24.6	20.0	16.9	14.6	12.1	9.88	-	- - - - -
	T_{out} [N·m]	-	-	4900	5790	6680	7570	7960	7960	7960	7960	7960	7960	7960	7960	7960	-	
	T_{out} [kgf·m]	-	-	499	590	681	772	811	811	811	811	811	811	811	811	811	-	
	Pro[N]	-	-	30000	31000	32300	34100	37100	39000	41200	43700	47200	49400	52000	55300	58400	-	
	Pro[kgf]	-	-	3060	3160	3290	3480	3780	3980	4200	4450	4810	5040	5300	5640	5950	-	
Frame Size	Ratio[Z]	6	8	11	13	15	17	21	25	29	35	43	51	59	71	87	119	Dim. Page
	n_2 [r/min]	163	123	89.1	75.4	65.3	57.6	46.7	39.2	33.8	28.0	22.8	19.2	16.6	13.8	11.3	8.24	

REDUCERS
Selection Tables
Ratio 6 - 119

Note: 1. Allowable radial load Pro is the value at the midpoint of the output shaft. Refer to pages F-11~12 when radial load is off the midpoint of output shaft and for checking thrust load.
 2. Refer to pages F-15~16 for allowable radial load for input shaft.

Selection Tables 6000 Series Reducer

Single Reduction Ratio 6 ~ 119 Frame Size: 6205 ~ 6275

Input Speed	$n_1 = 980$ r/min	n_1 : Input Speed [r/min]	T_{out} : Allowable output torque [N·m, kgf·m]
		n_2 : Output Speed [r/min]	Pro: Allowable output shaft radial load [N, kgf]
		P_1 : Allowable input power [kW]	*Consult us for Pro of CNF and CHF type.

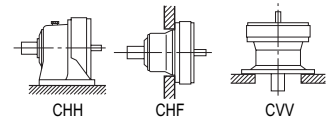

Selection Tables
Ratio 6 - 119
REDUCERS

Frame Size	n_2 [r/min] Ratio[Z]	163	123	89.1	75.4	65.3	57.6	46.7	39.2	33.8	28.0	22.8	19.2	16.6	13.8	11.3	8.24	Dim. Page	
		6	8	11	13	15	17	21	25	29	35	43	51	59	71	87	119		
6205	P_1 [kW]	-	-	59.7	-	59.7	-	47.7	-	34.4	-	23.4	-	17.0	-	10.9	-	CHH C-72 CHF C-77 CVW C-84	
	T_{out} [N·m]	-	-	6080	-	8290	-	9270	-	9230	-	9300	-	9300	-	8760	-		
	T_{out} [kgf·m]	-	-	620	-	845	-	945	-	941	-	948	-	948	-	893	-		
	Pro[N]	-	-	57700	-	61800	-	69400	-	76000	-	84100	-	84100	-	84100	-		
	Pro[kgf]	-	-	5880	-	6300	-	7070	-	7750	-	8570	-	8570	-	8570	-		
6215	P_1 [kW]	-	-	75.3	-	75.3	-	64.3	-	47.1	-	31.8	-	23.2	-	14.0	-	CHH C-72 CHF C-77 CVW C-84	
	T_{out} [N·m]	-	-	7670	-	10500	-	12500	-	12700	-	12700	-	12700	-	11300	-		
	T_{out} [kgf·m]	-	-	782	-	1070	-	1270	-	1290	-	1290	-	1290	-	1150	-		
	Pro[N]	-	-	58000	-	62000	-	70100	-	76600	-	87100	-	95100	-	104000	-		
	Pro[kgf]	-	-	5910	-	6320	-	7150	-	7810	-	8880	-	9690	-	10600	-		
6225	P_1 [kW]	-	-	99.5	-	99.5	-	76.1	-	56.0	-	40.2	-	29.1	-	18.7	-	CHH C-72 CHF C-77 CVW C-84	
	T_{out} [N·m]	-	-	10100	-	13800	-	14800	-	15000	-	16000	-	15900	-	15100	-		
	T_{out} [kgf·m]	-	-	1030	-	1410	-	1510	-	1530	-	1630	-	1620	-	1540	-		
	Pro[N]	-	-	61000	-	65500	-	73700	-	80800	-	91700	-	100000	-	113000	-		
	Pro[kgf]	-	-	6220	-	6680	-	7510	-	8240	-	9350	-	10200	-	11500	-		
6235	P_1 [kW]	-	-	113	-	113	-	97.2	-	70.4	-	47.6	-	34.6	-	21.3	-	CHH C-72 CHF C-77 CVW C-84	
	T_{out} [N·m]	-	-	11500	-	15700	-	18900	-	18900	-	18900	-	18900	-	17200	-		
	T_{out} [kgf·m]	-	-	1170	-	1600	-	1930	-	1930	-	1930	-	1930	-	1750	-		
	Pro[N]	-	-	76700	-	81700	-	91900	-	101000	-	114000	-	125000	-	141000	-		
	Pro[kgf]	-	-	7820	-	8330	-	9370	-	10300	-	11600	-	12700	-	14400	-		
6245	P_1 [kW]	-	-	132	-	132	-	120	-	94.2	-	64.8	-	47.2	-	28.1	-	CHH C-72 CHF C-77 CVW C-84	
	T_{out} [N·m]	-	-	13400	-	18300	-	23300	-	25300	-	25800	-	25800	-	22600	-		
	T_{out} [kgf·m]	-	-	1370	-	1870	-	2380	-	2580	-	2630	-	2630	-	2300	-		
	Pro[N]	-	-	85200	-	91100	-	102000	-	112000	-	126000	-	138000	-	157000	-		
	Pro[kgf]	-	-	8690	-	9290	-	10400	-	11400	-	12800	-	14100	-	16000	-		
6255	P_1 [kW]	-	-	151	-	151	-	151	-	118	-	77.9	-	56.8	-	38.5	-	CHH C-72 CHF C-77 CVW C-84	
	T_{out} [N·m]	-	-	15300	-	20900	-	29300	-	31800	-	31000	-	31000	-	31000	-		
	T_{out} [kgf·m]	-	-	1560	-	2130	-	2990	-	3240	-	3160	-	3160	-	3160	-		
	Pro[N]	-	-	104000	-	112000	-	124000	-	137000	-	155000	-	170000	-	192000	-		
	Pro[kgf]	-	-	10600	-	11400	-	12600	-	14000	-	15800	-	17300	-	19600	-		
6265	P_1 [kW]	-	-	175	-	175	-	172	-	159	-	113	-	84.2	-	53.4	-	CHH C-72 CHF C-77 CVW C-84	
	T_{out} [N·m]	-	-	17800	-	24300	-	33400	-	42700	-	45000	-	46000	-	43000	-		
	T_{out} [kgf·m]	-	-	1810	-	2480	-	3400	-	4350	-	4590	-	4690	-	4380	-		
	Pro[N]	-	-	128000	-	137000	-	152000	-	168000	-	189000	-	207000	-	234000	-		
	Pro[kgf]	-	-	13000	-	14000	-	15500	-	17100	-	19300	-	21100	-	23900	-		
6275	P_1 [kW]	-	-	-	-	-	-	-	-	159	-	151	-	125	-	53.4	-	CHH C-72 CVW C-84	
	T_{out} [N·m]	-	-	-	-	-	-	-	-	42700	-	60000	-	68200	-	43000	-		
	T_{out} [kgf·m]	-	-	-	-	-	-	-	-	-	4350	-	6120	-	6950	-	4380		-
	Pro[N]	-	-	-	-	-	-	-	-	-	196000	-	248000	-	248000	-	219000		-
	Pro[kgf]	-	-	-	-	-	-	-	-	-	20000	-	25300	-	25300	-	22300		-
Frame Size	n_2 [r/min] Ratio[Z]	6	8	11	13	15	17	21	25	29	35	43	51	59	71	87	119	Dim. Page	

Note: 1. Allowable radial load Pro is the value at the midpoint of the output shaft. Refer to pages F-11~12 when radial load is off the midpoint of output shaft and for checking thrust load.
2. Refer to pages F-15~16 for allowable radial load for input shaft.

M E M O

REDUCERS
Selection Tables
Ratio xxx - xxx

Selection Tables 6000 Series Reducer

Single Reduction Ratio 6 ~ 119 Frame Size: 6060 ~ 6120

Input Speed	$n_1 = 1165$ r/min	n_1 : Input Speed [r/min]	T_{out} : Allowable output torque [N·m, kgf·m]
		n_2 : Output Speed [r/min]	Pro: Allowable output shaft radial load [N, kgf]
		P_i : Allowable input power [kW]	*Consult us for Pro of CNF and CHF type.

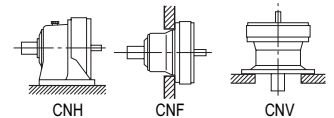

Selection Tables
Ratio 6 - 119
REDUCERS

Frame Size	n_2 [r/min] Ratio[Z]	194	146	106	89.6	77.7	68.5	55.5	46.6	40.2	33.3	27.1	22.8	19.7	16.4	13.4	9.79	Dim. Page
		6	8	11	13	15	17	21	25	29	35	43	51	59	71	87	119	
6060	P_i [kW]	0.200	0.200	0.200	0.200	0.200	0.181	0.147	0.110	0.106	0.088	0.072	-	-	-	-	-	CNH C-71
	T_{out} [N·m]	9.35	12.5	17.1	20.2	23.4	24.0	24.0	21.4	24.0	24.0	24.0	-	-	-	-	-	CNF C-76
	T_{out} [kgf·m]	0.953	1.27	1.74	2.06	2.39	2.45	2.45	2.18	2.45	2.45	2.45	-	-	-	-	-	CNV C-82
	Pro[N]	857	978	1180	1180	1180	1180	1180	1180	1180	1180	1180	-	-	-	-	-	-
	Pro[kgf]	87.4	100	120	120	120	120	120	120	120	120	120	-	-	-	-	-	-
6065	P_i [kW]	0.286	0.286	0.286	0.286	0.257	0.227	0.183	0.154	0.133	0.110	0.090	-	-	-	-	-	CNH C-71
	T_{out} [N·m]	13.4	17.8	24.5	29.0	30.0	30.0	30.0	30.0	30.0	30.0	30.0	-	-	-	-	-	CNF C-76
	T_{out} [kgf·m]	1.37	1.81	2.50	2.96	3.06	3.06	3.06	3.06	3.06	3.06	3.06	-	-	-	-	-	CNV C-82
	Pro[N]	850	968	1180	1180	1180	1180	1180	1180	1180	1180	1180	-	-	-	-	-	-
	Pro[kgf]	86.6	98.7	120	120	120	120	120	120	120	120	120	-	-	-	-	-	-
6070	P_i [kW]	0.347	0.347	0.347	0.347	0.347	0.340	0.275	0.230	0.199	0.165	0.134	0.100	0.098	-	-	-	CNH C-71
	T_{out} [N·m]	16.2	21.6	29.7	35.1	40.5	45.0	45.0	44.7	45.0	45.0	45.0	39.7	45.0	-	-	-	CNF C-76
	T_{out} [kgf·m]	1.65	2.20	3.03	3.58	4.13	4.59	4.59	4.56	4.59	4.59	4.59	4.05	4.59	-	-	-	CNV C-82
	Pro[N]	1470	1620	1770	1770	1770	1770	1770	1770	1770	1770	1770	1770	1770	-	-	-	-
	Pro[kgf]	150	165	180	180	180	180	180	180	180	180	180	180	180	-	-	-	-
6075	P_i [kW]	0.407	0.407	0.407	0.407	0.407	0.407	0.367	0.280	0.264	0.220	0.179	0.136	0.115	-	-	-	CNH C-71
	T_{out} [N·m]	19.0	25.3	34.9	41.2	47.5	53.9	60.0	54.6	59.6	60.0	60.0	54.2	52.9	-	-	-	CNF C-76
	T_{out} [kgf·m]	1.94	2.58	3.56	4.20	4.84	5.49	6.12	5.57	6.08	6.12	6.12	5.52	5.39	-	-	-	CNV C-82
	Pro[N]	1470	1610	1770	1770	1770	1770	1770	1770	1770	1770	1770	1660	1630	1660	-	-	-
	Pro[kgf]	150	164	180	180	180	180	180	180	180	180	180	169	166	169	-	-	-
6080	P_i [kW]	0.592	0.592	0.592	0.592	0.592	0.592	0.472	0.340	0.340	0.294	0.239	0.192	0.174	0.120	0.090	-	CNH C-71
	T_{out} [N·m]	27.7	36.9	50.7	60.0	69.2	78.4	77.2	66.2	76.8	80.0	80.0	76.3	80.0	66.3	61.0	-	CNF C-76
	T_{out} [kgf·m]	2.82	3.76	5.17	6.12	7.05	7.99	7.87	6.75	7.83	8.15	8.15	7.78	8.15	6.76	6.22	-	CNV C-82
	Pro[N]	2050	2210	2430	2560	2560	2560	2560	2560	2530	2560	2560	2540	2510	2510	2560	2560	-
	Pro[kgf]	209	225	248	261	261	261	261	261	258	261	261	259	256	256	261	261	-
6085	P_i [kW]	0.778	0.778	0.778	0.778	0.778	0.755	0.472	0.475	0.443	0.356	0.294	0.241	0.218	0.181	0.121	-	CNH C-71
	T_{out} [N·m]	36.3	48.5	66.6	78.7	90.8	100	77.2	92.4	100	97.1	98.4	95.8	100	100	82.1	-	CNF C-76
	T_{out} [kgf·m]	3.70	4.94	6.79	8.02	9.26	10.2	7.87	9.42	10.2	9.90	10.0	9.77	10.2	10.2	8.37	-	CNV C-82
	Pro[N]	2030	2190	2400	2560	2560	2560	2560	2450	2300	2460	2360	2330	2310	2260	2430	-	-
	Pro[kgf]	207	223	245	261	261	261	261	250	234	251	241	238	235	230	248	-	-
6090	P_i [kW]	1.15	1.15	1.15	1.15	1.15	1.13	0.758	0.671	0.625	0.550	0.435	0.332	0.298	0.239	0.211	0.117	CNH C-71
	T_{out} [N·m]	53.6	71.4	98.2	116	134	150	124	131	141	150	146	132	137	132	143	108	CNF C-76
	T_{out} [kgf·m]	5.46	7.28	10.0	11.8	13.7	15.3	12.6	13.4	14.4	15.3	14.9	13.5	14.0	13.5	14.6	11.0	CNV C-82
	Pro[N]	3010	3340	3340	3340	3340	3340	3340	3320	3310	3300	3320	3320	3320	3320	3310	3330	3310
	Pro[kgf]	307	340	340	340	340	340	340	338	337	336	338	338	338	337	339	337	-
6095	P_i [kW]	1.52	1.52	1.52	1.52	1.52	1.51	1.22	0.850	0.784	0.696	0.537	0.361	0.298	0.239	0.223	0.117	CNH C-71
	T_{out} [N·m]	70.8	94.4	130	153	177	200	200	166	177	190	180	143	137	132	151	108	CNF C-76
	T_{out} [kgf·m]	7.22	9.62	13.3	15.6	18.0	20.4	20.4	16.9	18.0	19.4	18.3	14.6	14.0	13.5	15.4	11.0	CNV C-82
	Pro[N]	2980	3290	3340	3340	3340	3340	3340	3250	3240	3220	3260	3290	3320	3310	3310	3310	-
	Pro[kgf]	304	335	340	340	340	340	340	331	330	328	332	335	338	337	337	337	-
6100	P_i [kW]	2.35	2.35	2.35	2.35	2.14	1.89	1.53	1.27	1.11	0.917	0.747	0.560	0.516	0.436	0.369	0.210	CNH C-71
	T_{out} [N·m]	110	146	201	238	250	250	250	247	250	250	250	222	237	241	250	195	CNF C-76
	T_{out} [kgf·m]	11.2	14.9	20.5	24.3	25.5	25.5	25.5	25.2	25.5	25.5	25.5	22.6	24.2	24.6	25.5	19.9	CNV C-82
	Pro[N]	4380	4870	5400	5400	5400	5400	5400	5400	5400	5400	5400	5400	5400	5400	5390	5390	-
	Pro[kgf]	446	496	550	550	550	550	550	550	550	550	550	550	550	550	549	549	-
6105	P_i [kW]	3.18	3.18	3.18	2.96	2.57	2.27	1.83	1.54	1.33	1.10	0.896	0.699	0.603	0.448	0.425	0.262	CNH C-71
	T_{out} [N·m]	149	198	272	300	300	300	300	300	300	300	300	278	277	248	288	243	CNF C-76
	T_{out} [kgf·m]	15.2	20.2	27.7	30.6	30.6	30.6	30.6	30.6	30.6	30.6	30.6	28.3	28.2	25.3	29.4	24.8	CNV C-82
	Pro[N]	4320	4800	5400	5400	5400	5400	5400	5400	5400	5400	5400	5400	5400	5400	5380	5360	-
	Pro[kgf]	440	489	550	550	550	550	550	550	550	550	550	550	550	550	548	546	-
6110	P_i [kW]	3.55	3.55	3.55	3.55	3.08	2.72	2.20	1.85	1.59	1.32	1.08	0.906	0.784	0.651	0.531	-	CNH C-71
	T_{out} [N·m]	166	221	304	359	360	360	360	360	360	360	360	360	360	360	360	-	CNF C-76
	T_{out} [kgf·m]	16.9	22.5	31.0	36.6	36.7	36.7	36.7	36.7	36.7	36.7	36.7	36.7	36.7	36.7	36.7	-	CNV C-82
	Pro[N]	4910	5450	6180	6370	6830	6930	7390	7340	7200	7280	7590	7590	7610	7580	7600	-	-
	Pro[kgf]	501	556	630	649	696	706	753	748	734	742	774	774	776	773	775	-	-
6115	P_i [kW]	3.92	3.92	3.92	3.90	3.60	3.17	2.57	2.16	1.86	1.54	1.25	1.06	0.914	0.758	0.620	-	CNH C-71
	T_{out} [N·m]	183	244	336	395	420	420	420	420	420	420	420	420	420	419	420	-	CNF C-76
	T_{out} [kgf·m]	18.7	24.9	34.3	40.3	42.8	42.8	42.8	42.8	42.8	42.8	42.8	42.8	42.8	42.7	42.8	-	CNV C-82
	Pro[N]	4890	5420	6150	6330	6760	6870	7320	7150	7010	7090	7370	7410	7430	7420	7410	-	-
	Pro[kgf]	498	552	627	645	689	700	746	729	715	723	751	755	757	756	755	-	-
6120	P_i [kW]	5.07	5.07	5.07	5.07	4.49	3.93	3.19	2.70	2.30	1.93	1.57	1.32	1.14	0.950	0.775	-	CNH C-71
	T_{out} [N·m]	237	316	434	513	525	520	522	525	520	525	525	525	525	525	525	-	CNF C-76
	T_{out} [kgf·m]	24.2	32.2	44.2	52.3	53.5	53.0	53.2	53.5	53.0	53.5	53.5	53.5	53.5	53.5	53.5	-	CNV C-82
	Pro[N]	5510	6130	6910	7100	7670	7790	8610	9070	9470	9810	9810	9810	9810	9810	9810	9780	-
	Pro[kgf]	562	625	704	724	782	794	878	925	965	1000	1000	1000	1000	1000	997	-	-
Frame Size	Ratio[Z]	6	8	11	13	15	17	21	25	29	35	43	51	59	71	87	119	Dim. Page
	n_2 [r/min]	194	146	106	89.6	77.7	68.5	55.5	46.6	40.2	33.3	27.1	22.8	19.7	16.4	13.4	9.79	

Note: 1. Allowable radial load Pro is the value at the midpoint of the output shaft. Refer to pages F-11~12 when radial load is off the midpoint of output shaft and for checking thrust load.

2. Refer to pages F-15~16 for allowable radial load for input shaft.

Selection Tables 6000 Series Reducer

Single Reduction Ratio 6 ~ 119 Frame Size: 6125 ~ 6195

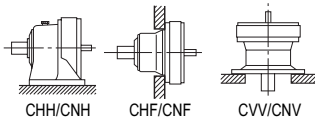

n_1 : Input Speed [r/min] T_{out} : Allowable output torque [N·m, kgf·m]
 n_2 : Output Speed [r/min] Pro: Allowable output shaft radial load [N, kgf]
 P_1 : Allowable input power [kW] *Consult us for Pro of CNF and CHF type.

Input Speed $n_1 = 1165$ r/min

Frame Size	n_2 [r/min] Ratio[Z]	194	146	106	89.6	77.7	68.5	55.5	46.6	40.2	33.3	27.1	22.8	19.7	16.4	13.4	9.79	Dim. Page	
6125	P_1 [kW]	6.96	6.82	5.91	5.34	5.39	4.76	3.85	3.24	2.79	2.31	1.88	1.59	1.37	0.963	0.868	-	- CNH C-71 CNF C-76 CNV C-82	
	T_{out} [N·m]	325	425	506	540	630	630	630	630	630	630	630	630	630	532	588	-		
	T_{out} [kgf·m]	33.1	43.3	51.6	55.0	64.2	64.2	64.2	64.2	64.2	64.2	64.2	64.2	64.2	54.2	59.9	-		
	Pro[N]	5420	6010	6840	7080	7560	7690	8510	8980	9380	9810	9810	9810	9810	9810	9810	9650		-
	Pro[kgf]	552	613	697	722	771	784	867	915	956	1000	1000	1000	1000	1000	1000	984		-
6130	P_1 [kW]	9.39	9.39	9.11	7.70	6.68	5.89	4.77	4.01	3.45	2.86	2.33	2.07	1.79	1.49	1.21	-	- CHH C-72 CHF C-77 CVV C-83	
	T_{out} [N·m]	439	585	780	780	780	780	780	780	780	780	780	821	821	821	821	-		
	T_{out} [kgf·m]	44.8	59.6	79.5	79.5	79.5	79.5	79.5	79.5	79.5	79.5	79.5	83.7	83.7	83.7	83.7	-		
	Pro[N]	6290	6980	7940	8360	8580	9260	9960	10400	11000	11600	12600	13100	13800	14700	14700	-		
	Pro[kgf]	641	712	809	852	875	944	1020	1060	1120	1180	1280	1340	1410	1500	1500	-		
6135	P_1 [kW]	11.3	10.5	10.7	8.65	8.05	7.10	5.69	4.62	4.13	3.45	2.81	2.16	2.06	1.71	1.40	-	- CHH C-72 CHF C-77 CVV C-83	
	T_{out} [N·m]	528	654	916	876	940	940	930	900	933	940	940	856	948	948	948	-		
	T_{out} [kgf·m]	53.8	66.7	93.4	89.3	95.8	95.8	94.8	91.7	95.1	95.8	95.8	87.3	96.6	96.6	96.6	-		
	Pro[N]	6190	6910	7820	8280	8460	9140	9840	10300	10900	11500	12400	13100	13700	14600	14700	-		
	Pro[kgf]	631	704	797	844	862	932	1000	1050	1110	1170	1260	1340	1400	1490	1500	-		
6140	P_1 [kW]	13.0	13.0	13.0	12.1	10.5	9.25	7.49	6.29	5.42	4.49	3.66	3.08	2.67	2.22	1.81	-	- CHH C-72 CHF C-77 CVV C-83	
	T_{out} [N·m]	609	811	1120	1230	1230	1230	1230	1230	1230	1230	1230	1230	1230	1230	1230	-		
	T_{out} [kgf·m]	62.1	82.7	114	125	125	125	125	125	125	125	125	125	125	125	125	-		
	Pro[N]	9820	10900	12200	12400	13100	13700	14700	15400	15800	16000	16000	16000	16000	16000	16000	-		
	Pro[kgf]	1000	1110	1240	1260	1340	1400	1500	1570	1610	1630	1630	1630	1630	1630	1630	-		
6145	P_1 [kW]	13.9	13.3	13.8	13.5	11.6	10.3	8.02	7.04	6.07	5.03	3.95	3.13	2.69	2.22	1.83	-	- CHH C-72 CHF C-77 CVV C-83	
	T_{out} [N·m]	651	828	1180	1360	1360	1370	1310	1370	1370	1370	1370	1320	1240	1240	1230	1240		-
	T_{out} [kgf·m]	66.4	84.4	120	139	139	140	134	140	140	140	140	135	126	126	125	126		-
	Pro[N]	9800	10900	12100	12400	13000	13600	14600	15400	15700	16000	15900	16000	16000	16000	16000	16000		-
	Pro[kgf]	999	1110	1230	1260	1330	1390	1490	1570	1600	1630	1620	1630	1630	1630	1630	1630		-
6160	P_1 [kW]	20.3	19.7	19.7	17.3	15.0	13.1	10.7	9.01	7.77	6.44	5.18	4.42	3.82	3.17	2.59	-	- CHH C-72 CHF C-77 CVV C-84	
	T_{out} [N·m]	948	1230	1690	1760	1760	1730	1760	1760	1760	1760	1760	1740	1760	1760	1760	-		
	T_{out} [kgf·m]	96.6	125	172	179	179	176	179	179	179	179	177	179	179	179	179	-		
	Pro[N]	10800	12000	13500	14200	15100	15700	17000	17900	18700	20000	21500	22100	22100	22100	22100	-		
	Pro[kgf]	1100	1220	1380	1450	1540	1600	1730	1820	1910	2040	2190	2250	2250	2250	2250	-		
6165	P_1 [kW]	24.1	24.1	24.1	20.7	18.0	15.9	12.8	10.8	9.30	7.70	6.27	5.29	4.57	3.80	3.03	-	- CHH C-72 CHF C-77 CVV C-84	
	T_{out} [N·m]	1120	1500	2060	2100	2100	2100	2100	2100	2100	2100	2100	2100	2100	2100	2050	-		
	T_{out} [kgf·m]	114	153	210	214	214	214	214	214	214	214	214	214	214	214	209	-		
	Pro[N]	10600	11800	13200	14000	14900	15500	16800	17700	18500	19800	21200	22100	22100	22100	21800	-		
	Pro[kgf]	1080	1200	1350	1430	1520	1580	1710	1800	1890	2020	2160	2250	2250	2250	2220	-		
6170	P_1 [kW]	27.6	27.6	27.6	25.0	21.7	19.1	15.5	13.0	11.2	9.28	7.56	6.37	5.51	4.58	3.73	-	- CHH C-72 CHF C-77 CVV C-84	
	T_{out} [N·m]	1290	1720	2360	2530	2530	2530	2530	2530	2530	2530	2530	2530	2530	2530	2530	-		
	T_{out} [kgf·m]	131	175	241	258	258	258	258	258	258	258	258	258	258	258	258	-		
	Pro[N]	12100	13300	15100	15800	16600	17400	19100	19900	21100	22500	24100	25200	26500	28200	29500	-		
	Pro[kgf]	1230	1360	1540	1610	1690	1770	1950	2030	2150	2290	2460	2570	2700	2870	3010	-		
6175	P_1 [kW]	30.1	30.1	30.1	30.1	25.4	23.8	19.3	16.2	13.9	11.6	9.41	7.93	6.86	5.70	4.65	-	- CHH C-72 CHF C-77 CVV C-84	
	T_{out} [N·m]	1410	1880	2580	3050	2970	3150	3150	3150	3150	3150	3150	3150	3150	3150	3150	-		
	T_{out} [kgf·m]	144	192	263	311	303	321	321	321	321	321	321	321	321	321	321	-		
	Pro[N]	12000	13200	14900	15400	16300	17000	18700	19600	20700	22100	23700	24900	26200	27900	29500	-		
	Pro[kgf]	1220	1350	1520	1570	1660	1730	1910	2000	2110	2250	2420	2540	2670	2840	3010	-		
6180	P_1 [kW]	-	-	35.2	35.2	32.4	30.6	24.8	20.8	17.9	14.9	12.1	10.2	8.82	7.33	5.99	-	- CHH C-72 CHF C-77 CVV C-84	
	T_{out} [N·m]	-	-	3020	3560	3780	4050	4050	4050	4050	4050	4060	4050	4050	4050	4060	-		
	T_{out} [kgf·m]	-	-	308	363	385	413	413	413	413	413	414	413	413	413	414	-		
	Pro[N]	-	-	20300	21000	22100	23400	25500	26600	27900	30000	32300	33600	35300	37600	40600	-		
	Pro[kgf]	-	-	2070	2140	2250	2390	2600	2710	2840	3060	3290	3430	3600	3830	4140	-		
6185	P_1 [kW]	-	-	39.0	39.0	34.0	32.3	30.6	25.7	22.1	18.3	14.9	12.6	10.9	8.16	7.38	-	- CHH C-72 CHF C-77 CVV C-84	
	T_{out} [N·m]	-	-	3340	3950	3970	4280	5000	5000	5000	5000	5000	5000	5000	4510	5000	-		
	T_{out} [kgf·m]	-	-	340	403	405	436	510	510	510	510	510	510	510	460	510	-		
	Pro[N]	-	-	20200	20900	22000	23300	25100	26200	27600	29700	31900	33300	34900	37400	40300	-		
	Pro[kgf]	-	-	2060	2130	2240	2380	2560	2670	2810	3030	3250	3390	3560	3810	4110	-		
6190	P_1 [kW]	-	-	41.0	41.0	41.0	41.0	39.0	32.8	28.3	23.4	18.8	16.1	13.9	11.5	9.42	-	- CHH C-72 CHF C-77 CVV C-84	
	T_{out} [N·m]	-	-	3510	4150	4790	5430	6380	6380	6380	6380	6310	6380	6380	6380	6380	-		
	T_{out} [kgf·m]	-	-	358	423	488	554	650	650	650	650	643	650	650	650	650	-		
	Pro[N]	-	-	28700	29700	31100	32800	35400	37200	39200	41600	44900	47000	49400	52500	56800	-		
	Pro[kgf]	-	-	2930	3030	3170	3340	3610	3790	4000	4240	4580	4790	5040	5350	5790	-		
6195	P_1 [kW]	-	-	48.1	48.1	48.1	48.1	48.1	40.5	35.2	29.2	23.0	20.0	17.3	14.4	11.7	-	- CHH C-72 CHF C-77 CVV C-84	
	T_{out} [N·m]	-	-	4120	4870	5620	6370	7870	7880	7960	7960	7690	7960	7960	7960	7960	-		
	T_{out} [kgf·m]	-	-	420	496	573	649	802	803	811	811	784	811	811	811	811	-		
	Pro[N]																		

Selection Tables 6000 Series Reducer

Single Reduction Ratio 6 ~ 119 Frame Size: 6205 ~ 6275

Input Speed	$n_1 = 1165$ r/min	n_1 : Input Speed [r/min]	T_{out} : Allowable output torque [N·m, kgf·m]
		n_2 : Output Speed [r/min]	Pro: Allowable output shaft radial load [N, kgf]
		P_1 : Allowable input power [kW]	*Consult us for Pro of CNF and CHF type.

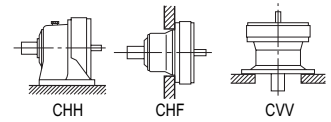

Selection Tables
Ratio 6 - 119
REDUCERS

Frame Size	n_2 [r/min] Ratio[Z]	194	146	106	89.6	77.7	68.5	55.5	46.6	40.2	33.3	27.1	22.8	19.7	16.4	13.4	9.79	Dim. Page	
		6	8	11	13	15	17	21	25	29	35	43	51	59	71	87	119		
6205	P_1 [kW]	-	-	59.7	-	59.7	-	54.7	-	39.6	-	27.8	-	19.5	-	12.9	-	CHH C-72 CHF C-77 CV C-84	
	T_{out} [N·m]	-	-	5110	-	6970	-	8950	-	8950	-	9300	-	8950	-	8760	-		
	T_{out} [kgf·m]	-	-	521	-	710	-	912	-	912	-	948	-	912	-	893	-		
	Pro[N]	-	-	55000	-	58900	-	65800	-	72100	-	81600	-	84100	-	84100	-		
	Pro[kgf]	-	-	5610	-	6000	-	6710	-	7350	-	8320	-	8570	-	8570	-		
6215	P_1 [kW]	-	-	75.3	-	75.3	-	75.3	-	56.0	-	37.8	-	27.5	-	16.6	-	CHH C-72 CHF C-77 CV C-84	
	T_{out} [N·m]	-	-	6450	-	8800	-	12300	-	12700	-	12700	-	12700	-	11300	-		
	T_{out} [kgf·m]	-	-	657	-	897	-	1250	-	1290	-	1290	-	1290	-	1150	-		
	Pro[N]	-	-	55300	-	59200	-	66400	-	72600	-	82500	-	90100	-	102000	-		
	Pro[kgf]	-	-	5640	-	6030	-	6770	-	7400	-	8410	-	9180	-	10400	-		
6225	P_1 [kW]	-	-	99.5	-	99.5	-	90.5	-	66.6	-	47.8	-	33.3	-	22.2	-	CHH C-72 CHF C-77 CV C-84	
	T_{out} [N·m]	-	-	8520	-	11600	-	14800	-	15000	-	16000	-	15300	-	15100	-		
	T_{out} [kgf·m]	-	-	869	-	1180	-	1510	-	1530	-	1630	-	1560	-	1540	-		
	Pro[N]	-	-	58200	-	62600	-	69800	-	76500	-	86800	-	95000	-	107000	-		
	Pro[kgf]	-	-	5930	-	6380	-	7120	-	7800	-	8850	-	9680	-	10900	-		
6235	P_1 [kW]	-	-	113	-	113	-	97.5	-	75.3	-	54.3	-	37.7	-	24.0	-	CHH C-72 CHF C-77 CV C-84	
	T_{out} [N·m]	-	-	9680	-	13200	-	15900	-	17000	-	18200	-	17300	-	16200	-		
	T_{out} [kgf·m]	-	-	987	-	1350	-	1620	-	1730	-	1860	-	1760	-	1650	-		
	Pro[N]	-	-	73100	-	77900	-	87700	-	96000	-	108000	-	119000	-	134000	-		
	Pro[kgf]	-	-	7450	-	7940	-	8940	-	9790	-	11000	-	12100	-	13700	-		
6245	P_1 [kW]	-	-	132	-	132	-	120	-	94.2	-	75.3	-	56.2	-	32.1	-	CHH C-72 CHF C-77 CV C-84	
	T_{out} [N·m]	-	-	11300	-	15400	-	19600	-	21300	-	25200	-	25800	-	21700	-		
	T_{out} [kgf·m]	-	-	1150	-	1570	-	2000	-	2170	-	2570	-	2630	-	2210	-		
	Pro[N]	-	-	81200	-	86900	-	97100	-	107000	-	120000	-	131000	-	149000	-		
	Pro[kgf]	-	-	8280	-	8860	-	9900	-	10900	-	12200	-	13400	-	15200	-		
6255	P_1 [kW]	-	-	151	-	151	-	151	-	118	-	88.9	-	64.8	-	42.9	-	CHH C-72 CHF C-77 CV C-84	
	T_{out} [N·m]	-	-	12900	-	17600	-	24600	-	26700	-	29800	-	29800	-	29000	-		
	T_{out} [kgf·m]	-	-	1310	-	1790	-	2510	-	2720	-	3040	-	3040	-	2960	-		
	Pro[N]	-	-	99600	-	107000	-	118000	-	131000	-	147000	-	161000	-	182000	-		
	Pro[kgf]	-	-	10200	-	10900	-	12000	-	13400	-	15000	-	16400	-	18600	-		
6265	P_1 [kW]	-	-	175	-	175	-	172	-	159	-	113	-	94.2	-	53.4	-	CHH C-72 CHF C-77 CV C-84	
	T_{out} [N·m]	-	-	15000	-	20400	-	28100	-	35900	-	37800	-	43300	-	36200	-		
	T_{out} [kgf·m]	-	-	1530	-	2080	-	2860	-	3660	-	3850	-	4410	-	3690	-		
	Pro[N]	-	-	122000	-	130000	-	145000	-	160000	-	180000	-	197000	-	222000	-		
	Pro[kgf]	-	-	12400	-	13300	-	14800	-	16300	-	18300	-	20100	-	22600	-		
6275	P_1 [kW]	-	-	-	-	-	-	-	-	159	-	151	-	132	-	53.4	-	CHH C-72 CV C-84	
	T_{out} [N·m]	-	-	-	-	-	-	-	-	35900	-	50500	-	60600	-	36200	-		
	T_{out} [kgf·m]	-	-	-	-	-	-	-	-	-	3660	-	5150	-	6180	-	3690		-
	Pro[N]	-	-	-	-	-	-	-	-	-	186000	-	248000	-	247000	-	208000		-
	Pro[kgf]	-	-	-	-	-	-	-	-	-	19000	-	25300	-	25200	-	21200		-
Frame Size	n_2 [r/min] Ratio[Z]	6	8	11	13	15	17	21	25	29	35	43	51	59	71	87	119	Dim. Page	

Note: 1. Allowable radial load Pro is the value at the midpoint of the output shaft. Refer to pages F-11~12 when radial load is off the midpoint of output shaft and for checking thrust load.
2. Refer to pages F-15~16 for allowable radial load for input shaft.

M E M O

REDUCERS
Selection Tables
Ratio xxx - xxx

Selection Tables 6000 Series Reducer

Single Reduction Ratio 6 ~ 119 Frame Size: 6060 ~ 6120

Input Speed	$n_1 = 1450$ r/min	n_1 : Input Speed [r/min]	T_{out} : Allowable output torque [N·m, kgf·m]
		n_2 : Output Speed [r/min]	Pro: Allowable output shaft radial load [N, kgf]
		P_i : Allowable input power [kW]	*Consult us for Pro of CNF and CHF type.

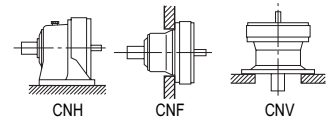

Selection Tables
Ratio 6 - 119
REDUCERS

Frame Size	n_2 [r/min] Ratio[Z]	242	181	132	112	96.7	85.3	69.0	58.0	50.0	41.4	33.7	28.4	24.6	20.4	16.7	12.2	Dim. Page
		6	8	11	13	15	17	21	25	29	35	43	51	59	71	87	119	
6060	P_i [kW]	0.200	0.200	0.200	0.200	0.200	0.200	0.183	0.110	0.110	0.110	0.089	-	-	-	-	-	CNH C-71 CNF C-76 CNV C-82
	T_{out} [N·m]	7.51	10.0	13.8	16.3	18.8	21.3	24.0	17.2	20.0	24.0	24.0	-	-	-	-	-	
	T_{out} [kgf·m]	0.766	1.02	1.41	1.66	1.92	2.17	2.45	1.75	2.04	2.45	2.45	-	-	-	-	-	
	Pro[N]	798	912	1180	1180	1180	1180	1180	1180	1180	1180	1180	-	-	-	-	-	
	Pro[kgf]	81.3	93	120	120	120	120	120	120	120	120	120	-	-	-	-	-	
6065	P_i [kW]	0.286	0.286	0.286	0.286	0.286	0.282	0.228	0.166	0.165	0.137	0.112	-	-	-	-	-	CNH C-71 CNF C-76 CNV C-82
	T_{out} [N·m]	10.7	14.3	19.7	23.3	26.9	30.0	30.0	25.9	30.0	30.0	30.0	-	-	-	-	-	
	T_{out} [kgf·m]	1.09	1.46	2.01	2.38	2.74	3.06	3.06	2.64	3.06	3.06	3.06	-	-	-	-	-	
	Pro[N]	793	904	1180	1180	1180	1180	1180	1180	1180	1180	1180	-	-	-	-	-	
	Pro[kgf]	80.8	92.2	120	120	120	120	120	120	120	120	120	-	-	-	-	-	
6070	P_i [kW]	0.347	0.347	0.347	0.347	0.347	0.347	0.320	0.230	0.226	0.205	0.167	0.100	0.100	-	-	-	CNH C-71 CNF C-76 CNV C-82
	T_{out} [N·m]	13.0	17.3	23.9	28.2	32.5	36.9	42.1	35.9	41.0	45.0	45.0	31.9	36.9	-	-	-	
	T_{out} [kgf·m]	1.33	1.76	2.44	2.87	3.31	3.76	4.29	3.66	4.18	4.59	4.59	3.25	3.76	-	-	-	
	Pro[N]	1380	1520	1690	1770	1770	1770	1770	1770	1770	1770	1770	1770	1770	-	-	-	
	Pro[kgf]	141	155	172	180	180	180	180	180	180	180	180	180	180	-	-	-	
6075	P_i [kW]	0.407	0.407	0.407	0.407	0.407	0.407	0.407	0.294	0.286	0.272	0.223	0.143	0.136	-	-	-	CNH C-71 CNF C-76 CNV C-82
	T_{out} [N·m]	15.3	20.4	28.0	33.1	38.2	43.3	53.5	46.0	52.0	59.6	60.0	45.7	50.1	-	-	-	
	T_{out} [kgf·m]	1.56	2.08	2.85	3.37	3.89	4.41	5.45	4.69	5.30	6.08	6.12	4.66	5.11	-	-	-	
	Pro[N]	1370	1510	1680	1770	1770	1770	1770	1770	1770	1770	1660	1750	1700	-	-	-	
	Pro[kgf]	140	154	171	180	180	180	180	180	180	180	169	178	173	-	-	-	
6080	P_i [kW]	0.592	0.592	0.592	0.592	0.592	0.592	0.478	0.340	0.340	0.290	0.250	0.192	0.185	0.120	0.090	-	CNH C-71 CNF C-76 CNV C-82
	T_{out} [N·m]	22.2	29.6	40.8	48.2	55.6	63.0	62.9	53.2	61.7	74.5	67.3	61.3	68.1	53.3	49.0	-	
	T_{out} [kgf·m]	2.26	3.02	4.16	4.91	5.67	6.42	6.41	5.42	6.29	7.59	6.86	6.25	6.94	5.43	4.99	-	
	Pro[N]	1910	2060	2270	2440	2510	2560	2560	2560	2560	2560	2560	2560	2560	2560	2560	-	
	Pro[kgf]	195	210	231	249	256	261	261	261	261	261	261	261	261	261	261	-	
6085	P_i [kW]	0.778	0.778	0.778	0.778	0.778	0.778	0.550	0.475	0.467	0.327	0.294	0.241	0.234	0.165	0.121	-	CNH C-71 CNF C-76 CNV C-82
	T_{out} [N·m]	29.2	38.9	53.5	63.3	73.0	82.7	72.3	74.3	84.8	90.2	79.1	76.9	86.2	89.7	66.0	-	
	T_{out} [kgf·m]	2.98	3.97	5.45	6.45	7.44	8.43	7.37	7.57	8.64	9.19	8.06	7.84	8.79	9.14	6.73	-	
	Pro[N]	1900	2050	2250	2410	2480	2560	2560	2560	2460	2530	2550	2510	2450	2370	2560	-	
	Pro[kgf]	194	209	229	246	253	261	261	261	251	258	260	256	250	242	261	-	
6090	P_i [kW]	1.15	1.15	1.15	1.15	1.15	1.15	0.758	0.671	0.625	0.612	0.435	0.332	0.309	0.252	0.211	0.125	CNH C-71 CNF C-76 CNV C-82
	T_{out} [N·m]	43.0	57.4	78.9	93.2	108	122	99.5	105	113	134	117	106	114	112	115	93.1	
	T_{out} [kgf·m]	4.38	5.85	8.04	9.50	11.0	12.4	10.1	10.7	11.5	13.7	11.9	10.8	11.6	11.4	11.7	9.49	
	Pro[N]	2810	3120	3340	3340	3340	3340	3340	3340	3340	3330	3340	3340	3340	3340	3340	3340	
	Pro[kgf]	286	318	340	340	340	340	340	340	339	340	340	340	340	340	340	340	
6095	P_i [kW]	1.52	1.52	1.52	1.52	1.52	1.52	1.51	0.866	0.784	0.758	0.603	0.407	0.336	0.278	0.263	0.145	CNH C-71 CNF C-76 CNV C-82
	T_{out} [N·m]	56.9	75.8	104	123	142	161	198	136	142	166	162	130	124	124	143	108	
	T_{out} [kgf·m]	5.80	7.73	10.6	12.5	14.5	16.4	20.2	13.9	14.5	16.9	16.5	13.3	12.6	12.6	14.6	11.0	
	Pro[N]	2780	3080	3340	3340	3340	3340	3340	3310	3310	3270	3290	3320	3340	3330	3330	3310	
	Pro[kgf]	283	314	340	340	340	340	337	337	333	335	338	340	339	339	337	337	
6100	P_i [kW]	2.35	2.35	2.35	2.35	2.35	1.99	1.90	1.27	1.21	0.975	0.780	0.560	0.516	0.436	0.433	0.210	CNH C-71 CNF C-76 CNV C-82
	T_{out} [N·m]	88.1	117	162	191	220	211	250	199	220	214	210	179	190	194	236	156	
	T_{out} [kgf·m]	8.98	11.9	16.5	19.5	22.4	21.5	25.5	20.3	22.4	21.8	21.4	18.2	19.4	19.8	24.1	15.9	
	Pro[N]	4090	4550	5150	5350	5400	5400	5400	5400	5400	5400	5400	5400	5400	5400	5400	5400	
	Pro[kgf]	417	464	525	545	550	550	550	550	550	550	550	550	550	550	550	550	
6105	P_i [kW]	3.18	3.18	3.18	3.18	3.18	2.46	2.28	1.67	1.59	1.20	1.08	0.776	0.681	0.506	0.503	0.286	CNH C-71 CNF C-76 CNV C-82
	T_{out} [N·m]	119	159	219	259	298	261	300	262	288	262	292	248	251	225	274	213	
	T_{out} [kgf·m]	12.1	16.2	22.3	26.4	30.4	26.6	30.6	26.7	29.4	26.7	29.8	25.3	25.6	22.9	27.9	21.7	
	Pro[N]	4050	4490	5080	5270	5400	5400	5400	5400	5400	5400	5400	5400	5400	5400	5400	5380	
	Pro[kgf]	413	458	518	537	550	550	550	550	550	550	550	550	550	550	548	548	
6110	P_i [kW]	3.55	3.55	3.55	3.55	3.55	3.18	2.72	1.91	1.90	1.50	1.30	0.944	0.859	0.669	0.661	-	CNH C-71 CNF C-76 CNV C-82
	T_{out} [N·m]	133	178	244	289	333	338	358	299	346	329	350	301	317	297	360	-	
	T_{out} [kgf·m]	13.6	18.1	24.9	29.5	33.9	34.5	36.5	30.5	35.3	33.5	35.7	30.7	32.3	30.3	36.7	-	
	Pro[N]	4590	5100	5790	5970	6350	6440	6850	7060	7210	7310	7600	7610	7610	7610	7600	-	
	Pro[kgf]	468	520	590	609	647	656	698	720	735	745	775	776	776	776	775	-	
6115	P_i [kW]	3.92	3.92	3.92	3.90	3.90	3.90	3.11	2.22	2.22	1.81	1.52	1.11	1.01	0.758	0.758	-	CNH C-71 CNF C-76 CNV C-82
	T_{out} [N·m]	147	196	270	317	366	415	409	348	403	396	408	355	373	337	412	-	
	T_{out} [kgf·m]	15.0	20.0	27.5	32.3	37.3	42.3	41.7	35.5	41.1	40.4	41.6	36.2	38.0	34.4	42.0	-	
	Pro[N]	4570	5070	5760	5940	6310	6360	6790	7010	7160	7240	7540	7600	7610	7600	7550	-	
	Pro[kgf]	466	517	587	606	643	648	692	715	730	738	769	775	776	775	770	-	
6120	P_i [kW]	5.07	5.07	5.07	5.07	5.07	4.89	3.96	3.09	2.87	2.37	1.91	1.63	1.30	0.957	0.944	-	CNH C-71 CNF C-76 CNV C-82
	T_{out} [N·m]	190	254	349	412	476	520	520	483	520	520	515	520	482	425	514	-	
	T_{out} [kgf·m]	19.4	25.9	35.6	42.0	48.5	53.0	53.0	49.2	53.0	53.0	52.5	53.0	49.1	43.3	52.4	-	
	Pro[N]	5160	5740	6480	6670	7140	7210	7980	8440	8780	9320	9810	9810	9810	9810	9800	-	
	Pro[kgf]	526	585	661	680	728	735	813	860	895	950	1000	1000	1000	1000	999	-	

Note: 1. Allowable radial load Pro is the value at the midpoint of the output shaft. Refer to pages F-11~12 when radial load is off the midpoint of output shaft and for checking thrust load.

2. Refer to pages F-15~16 for allowable radial load for input shaft.

Selection Tables 6000 Series Reducer

Single Reduction Ratio 6 ~ 119 Frame Size: 6125 ~ 6195

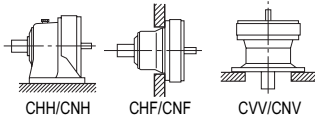

n_1 : Input Speed [r/min] T_{out} : Allowable output torque [N·m, kgf·m]
 n_2 : Output Speed [r/min] Pro: Allowable output shaft radial load [N, kgf]
 P_1 : Allowable input power [kW] *Consult us for Pro of CNF and CHF type.

Input Speed $n_1 = 1450$ r/min

Frame Size	n_2 [r/min] Ratio[Z]	242	181	132	112	96.7	85.3	69.0	58.0	50.0	41.4	33.7	28.4	24.6	20.4	16.7	12.2	Dim. Page
6125	P_1 [kW]	6.96	6.95	5.92	5.92	5.92	5.66	4.79	3.96	3.47	2.88	2.34	1.97	1.62	1.14	1.03	-	CNH C-71 CNF C-76 CNV C-82
	T_{out} [N·m]	261	348	407	482	556	602	630	619	630	630	630	630	598	506	559	-	
	T_{out} [kgf·m]	26.6	35.5	41.5	49.1	56.7	61.4	64.2	63.1	64.2	64.2	64.2	64.2	61.0	51.6	57.0	-	
	Pro[N]	5080	5640	6420	6600	7060	7130	7870	8310	8680	9220	9810	9810	9810	9810	9710	-	
	Pro[kgf]	518	575	654	673	720	727	802	847	885	940	1000	1000	1000	1000	990	-	
6130	P_1 [kW]	9.39	9.39	9.39	9.39	7.78	7.27	5.94	4.99	4.30	3.56	2.90	2.44	2.11	1.76	1.42	-	C-72 C-77 C-83
	T_{out} [N·m]	353	470	646	764	731	774	780	780	780	780	780	780	780	780	772	-	
	T_{out} [kgf·m]	36.0	47.9	65.9	77.9	74.5	78.9	79.5	79.5	79.5	79.5	79.5	79.5	79.5	79.5	78.7	-	
	Pro[N]	5910	6560	7460	7740	7980	8570	9220	9640	10200	10800	11600	12200	12800	13600	14700	-	
	Pro[kgf]	602	669	760	789	813	874	940	983	1040	1100	1180	1240	1300	1390	1500	-	
6135	P_1 [kW]	11.3	11.3	11.3	10.2	8.97	8.29	6.72	5.75	4.88	4.11	3.35	2.55	2.44	2.03	1.65	-	C-72 C-77 C-83
	T_{out} [N·m]	424	566	778	832	842	882	883	900	886	900	900	813	900	900	900	-	
	T_{out} [kgf·m]	43.2	57.7	79.3	84.8	85.8	89.9	90.0	91.7	90.3	91.7	91.7	82.9	91.7	91.7	91.7	-	
	Pro[N]	5830	6470	7340	7680	7890	8490	9140	9550	10100	10700	11500	12100	12700	13600	14700	-	
	Pro[kgf]	594	660	748	783	804	865	932	973	1030	1090	1170	1230	1290	1390	1500	-	
6140	P_1 [kW]	13.0	13.0	13.0	13.0	12.0	10.1	8.66	6.89	5.95	5.21	3.94	3.43	2.96	2.43	1.98	-	C-72 C-77 C-83
	T_{out} [N·m]	489	652	896	1060	1130	1070	1140	1080	1080	1140	1060	1090	1090	1080	1080	-	
	T_{out} [kgf·m]	49.8	66.5	91.3	108	115	109	116	110	110	116	108	111	111	110	110	-	
	Pro[N]	9230	10200	11400	11700	12200	12800	13700	14500	14800	15900	16000	16000	16000	16000	16000	-	
	Pro[kgf]	941	1040	1160	1190	1240	1300	1400	1480	1510	1620	1630	1630	1630	1630	1630	-	
6145	P_1 [kW]	15.1	15.1	15.1	15.1	14.5	12.0	9.49	7.91	7.53	6.26	4.67	3.70	3.18	2.62	2.16	-	C-72 C-77 C-83
	T_{out} [N·m]	569	758	1040	1230	1360	1280	1250	1240	1370	1370	1260	1180	1170	1160	1170	-	
	T_{out} [kgf·m]	58.0	77.3	106	125	139	130	127	126	140	140	128	120	119	118	119	-	
	Pro[N]	9200	10200	11400	11600	12100	12800	13700	14400	14700	15800	16000	16000	16000	16000	16000	-	
	Pro[kgf]	938	1040	1160	1180	1230	1300	1400	1470	1500	1610	1630	1630	1630	1630	1630	-	
6160	P_1 [kW]	20.3	19.7	19.7	19.7	18.7	13.1	12.9	9.86	9.56	8.01	6.45	5.50	4.42	3.47	3.22	-	C-72 C-77 C-84
	T_{out} [N·m]	762	986	1360	1600	1760	1390	1700	1540	1740	1760	1740	1760	1630	1540	1760	-	
	T_{out} [kgf·m]	77.7	101	139	163	179	142	173	157	177	179	177	179	166	157	179	-	
	Pro[N]	10100	11300	12700	13200	14000	14800	15800	16700	17300	18500	19900	20800	22100	22100	22100	-	
	Pro[kgf]	1030	1150	1290	1350	1430	1510	1610	1700	1760	1890	2030	2120	2250	2250	2250	-	
6165	P_1 [kW]	24.1	24.1	24.1	22.6	22.4	18.8	16.0	13.4	11.4	9.59	7.81	6.58	5.69	4.73	3.77	-	C-72 C-77 C-84
	T_{out} [N·m]	903	1200	1660	1840	2100	2000	2100	2100	2070	2100	2100	2100	2100	2100	2050	-	
	T_{out} [kgf·m]	92.0	122	169	188	214	204	214	214	211	214	214	214	214	214	209	-	
	Pro[N]	9990	11100	12500	13100	13800	14300	15500	16300	17100	18300	19600	20600	22100	22100	21800	-	
	Pro[kgf]	1020	1130	1270	1340	1410	1460	1580	1660	1740	1870	2000	2100	2250	2250	2220	-	
6170	P_1 [kW]	27.6	27.6	27.6	27.3	25.5	19.7	18.6	15.6	13.5	11.2	9.08	7.66	6.62	5.50	4.57	-	C-72 C-77 C-84
	T_{out} [N·m]	1040	1380	1900	2220	2390	2090	2440	2440	2440	2440	2440	2440	2440	2450	2490	-	
	T_{out} [kgf·m]	106	141	194	226	244	213	249	249	249	249	249	249	249	250	254	-	
	Pro[N]	11300	12500	14200	14700	15400	16400	17700	18500	19500	20800	22300	23400	24600	26200	28100	-	
	Pro[kgf]	1150	1270	1450	1500	1570	1670	1800	1890	1990	2120	2270	2390	2510	2670	2860	-	
6175	P_1 [kW]	30.1	30.1	30.1	30.1	30.1	24.1	23.6	19.5	17.4	14.4	11.3	9.87	8.29	6.98	5.62	-	C-72 C-77 C-84
	T_{out} [N·m]	1130	1510	2070	2450	2820	2560	3100	3050	3150	3150	3040	3150	3060	3100	3060	-	
	T_{out} [kgf·m]	115	154	211	250	287	261	316	311	321	321	310	321	312	316	312	-	
	Pro[N]	11300	12400	14100	14600	15100	16100	17300	18100	19200	20500	22000	23000	24300	25800	27800	-	
	Pro[kgf]	1150	1260	1440	1490	1540	1640	1760	1850	1960	2090	2240	2340	2480	2630	2830	-	
6180	P_1 [kW]	-	-	35.2	35.2	32.4	30.6	30.0	24.1	19.5	18.5	15.1	12.0	9.75	8.80	7.15	-	C-72 C-77 C-84
	T_{out} [N·m]	-	-	2420	2860	3040	3250	3940	3760	3540	4050	4050	3830	3600	3910	3890	-	
	T_{out} [kgf·m]	-	-	247	292	310	331	402	383	361	413	413	390	367	399	397	-	
	Pro[N]	-	-	19100	19800	20800	22000	23600	24700	26100	27800	29900	31200	32800	34900	37700	-	
	Pro[kgf]	-	-	1950	2020	2120	2240	2410	2520	2660	2830	3050	3180	3340	3560	3840	-	
6185	P_1 [kW]	-	-	39.0	39.0	39.0	38.2	38.1	30.1	24.1	22.6	18.6	15.1	12.0	9.79	8.59	-	C-72 C-77 C-84
	T_{out} [N·m]	-	-	2680	3170	3660	4060	5000	4710	4360	4950	5000	4810	4430	4350	4680	-	
	T_{out} [kgf·m]	-	-	273	323	373	414	510	480	444	505	510	490	452	443	477	-	
	Pro[N]	-	-	19000	19600	20500	21600	23200	24400	25800	27500	29500	30900	32500	34800	37400	-	
	Pro[kgf]	-	-	1940	2000	2090	2200	2360	2490	2630	2800	3010	3150	3310	3550	3810	-	
6190	P_1 [kW]	-	-	41.0	41.0	41.0	41.0	41.0	35.2	30.7	24.3	20.9	18.2	15.3	13.5	11.7	-	C-72 C-77 C-84
	T_{out} [N·m]	-	-	2820	3330	3850	4360	5390	5500	5570	5320	5640	5800	5640	6000	6380	-	
	T_{out} [kgf·m]	-	-	287	339	392	444	549	561	568	542	575	591	575	612	650	-	
	Pro[N]	-	-	26900	27800	29200	30700	33000	34700	36500	38800	41800	43700	46000	48800	52600	-	
	Pro[kgf]	-	-	2740	2830	2980	3130	3360	3540	3720	3960	4260	4450	4690	4970	5360	-	
6195	P_1 [kW]	-	-	48.1	48.1	48.1	48.1	48.1	40.5	37.8	30.1	27.1	20.9	18.8	15.6	13.6	-	C-72 C-77 C-84
	T_{out} [N·m]	-	-	3310	3910	4510	5120	6320	6330	6860	6600	7300	6680	6950	6930	7420	-	
	T_{out} [kgf·m]	-	-	337	399	460	522	644	645	699	673	744	681	708	706	756	-	
	Pro[N]	-	-	26700	27600	28900	30500	32700	34400	36200	38400	41400	43500	45700	48500	52300	-	
	Pro[kgf]																	

Selection Tables 6000 Series Reducer

Single Reduction Ratio 6 ~ 119 Frame Size: 6205 ~ 6275

Input Speed	$n_1 = 1450$ r/min	n_1 : Input Speed [r/min]	T_{out} : Allowable output torque [N·m, kgf·m]
		n_2 : Output Speed [r/min]	Pro: Allowable output shaft radial load [N, kgf]
		P_1 : Allowable input power [kW]	*Consult us for Pro of CNF and CHF type.

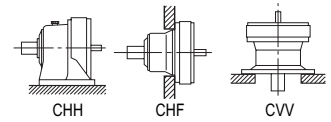

Selection Tables
Ratio 6 - 119
REDUCERS

Frame Size	n_2 [r/min] Ratio[Z]	242	181	132	112	96.7	85.3	69.0	58.0	50.0	41.4	33.7	28.4	24.6	20.4	16.7	12.2	Dim. Page
		6	8	11	13	15	17	21	25	29	35	43	51	59	71	87	119	
6205	P_1 [kW]	-	-	59.7	-	59.7	-	59.2	-	45.7	-	31.8	-	22.6	-	15.9	-	CHH C-72 CHF C-77 CVW C-84
	T_{out} [N·m]	-	-	4110	-	5600	-	7780	-	8280	-	8550	-	8340	-	8650	-	
	T_{out} [kgf·m]	-	-	419	-	571	-	793	-	844	-	872	-	850	-	882	-	
	Pro[N]	-	-	51700	-	55400	-	61800	-	67500	-	76500	-	83500	-	84100	-	
	Pro[kgf]	-	-	5270	-	5650	-	6300	-	6880	-	7800	-	8510	-	8570	-	
6215	P_1 [kW]	-	-	75.3	-	75.3	-	75.3	-	58.5	-	45.2	-	33.9	-	19.7	-	CHH C-72 CHF C-77 CVW C-84
	T_{out} [N·m]	-	-	5190	-	7070	-	9900	-	10600	-	12200	-	12500	-	10700	-	
	T_{out} [kgf·m]	-	-	529	-	721	-	1010	-	1080	-	1240	-	1270	-	1090	-	
	Pro[N]	-	-	52000	-	55700	-	62600	-	68300	-	77200	-	84200	-	95400	-	
	Pro[kgf]	-	-	5300	-	5680	-	6380	-	6960	-	7870	-	8580	-	9720	-	
6225	P_1 [kW]	-	-	99.5	-	99.5	-	94.2	-	75.3	-	56.5	-	39.3	-	26.7	-	CHH C-72 CHF C-77 CVW C-84
	T_{out} [N·m]	-	-	6850	-	9330	-	12400	-	13700	-	15200	-	14500	-	14600	-	
	T_{out} [kgf·m]	-	-	698	-	951	-	1260	-	1400	-	1550	-	1480	-	1490	-	
	Pro[N]	-	-	54800	-	59000	-	65700	-	71800	-	81300	-	89000	-	100000	-	
	Pro[kgf]	-	-	5590	-	6010	-	6700	-	7320	-	8290	-	9070	-	10200	-	
6235	P_1 [kW]	-	-	-	-	-	-	-	-	-	-	-	-	-	-	-	-	CHH C-72 CHF C-77 CVW C-84
	T_{out} [N·m]	-	-	-	-	-	-	-	-	-	-	-	-	-	-	-	-	
	T_{out} [kgf·m]	-	-	-	-	-	-	-	-	-	-	-	-	-	-	-	-	
	Pro[N]	-	-	-	-	-	-	-	-	-	-	-	-	-	-	-	-	
	Pro[kgf]	-	-	-	-	-	-	-	-	-	-	-	-	-	-	-	-	
6245	P_1 [kW]	-	-	-	-	-	-	-	-	-	-	-	-	-	-	-	-	CHH C-72 CHF C-77 CVW C-84
	T_{out} [N·m]	-	-	-	-	-	-	-	-	-	-	-	-	-	-	-	-	
	T_{out} [kgf·m]	-	-	-	-	-	-	-	-	-	-	-	-	-	-	-	-	
	Pro[N]	-	-	-	-	-	-	-	-	-	-	-	-	-	-	-	-	
	Pro[kgf]	-	-	-	-	-	-	-	-	-	-	-	-	-	-	-	-	
6255	P_1 [kW]	-	-	-	-	-	-	-	-	-	-	-	-	-	-	-	-	CHH C-72 CHF C-77 CVW C-84
	T_{out} [N·m]	-	-	-	-	-	-	-	-	-	-	-	-	-	-	-	-	
	T_{out} [kgf·m]	-	-	-	-	-	-	-	-	-	-	-	-	-	-	-	-	
	Pro[N]	-	-	-	-	-	-	-	-	-	-	-	-	-	-	-	-	
	Pro[kgf]	-	-	-	-	-	-	-	-	-	-	-	-	-	-	-	-	
6265	P_1 [kW]	-	-	-	-	-	-	-	-	-	-	-	-	-	-	-	-	CHH C-72 CHF C-77 CVW C-84
	T_{out} [N·m]	-	-	-	-	-	-	-	-	-	-	-	-	-	-	-	-	
	T_{out} [kgf·m]	-	-	-	-	-	-	-	-	-	-	-	-	-	-	-	-	
	Pro[N]	-	-	-	-	-	-	-	-	-	-	-	-	-	-	-	-	
	Pro[kgf]	-	-	-	-	-	-	-	-	-	-	-	-	-	-	-	-	
6275	P_1 [kW]	-	-	-	-	-	-	-	-	-	-	-	-	-	-	-	-	CHH C-72 CVW C-84
	T_{out} [N·m]	-	-	-	-	-	-	-	-	-	-	-	-	-	-	-	-	
	T_{out} [kgf·m]	-	-	-	-	-	-	-	-	-	-	-	-	-	-	-	-	
	Pro[N]	-	-	-	-	-	-	-	-	-	-	-	-	-	-	-	-	
	Pro[kgf]	-	-	-	-	-	-	-	-	-	-	-	-	-	-	-	-	
Frame Size	n_2 [r/min]	242	181	132	112	96.7	85.3	69.0	58.0	50.0	41.4	33.7	28.4	24.6	20.4	16.7	12.2	Dim. Page

Note: 1. Allowable radial load Pro is the value at the midpoint of the output shaft. Refer to pages F-11~12 when radial load is off the midpoint of output shaft and for checking thrust load.
2. Refer to pages F-15~16 for allowable radial load for input shaft.

M E M O

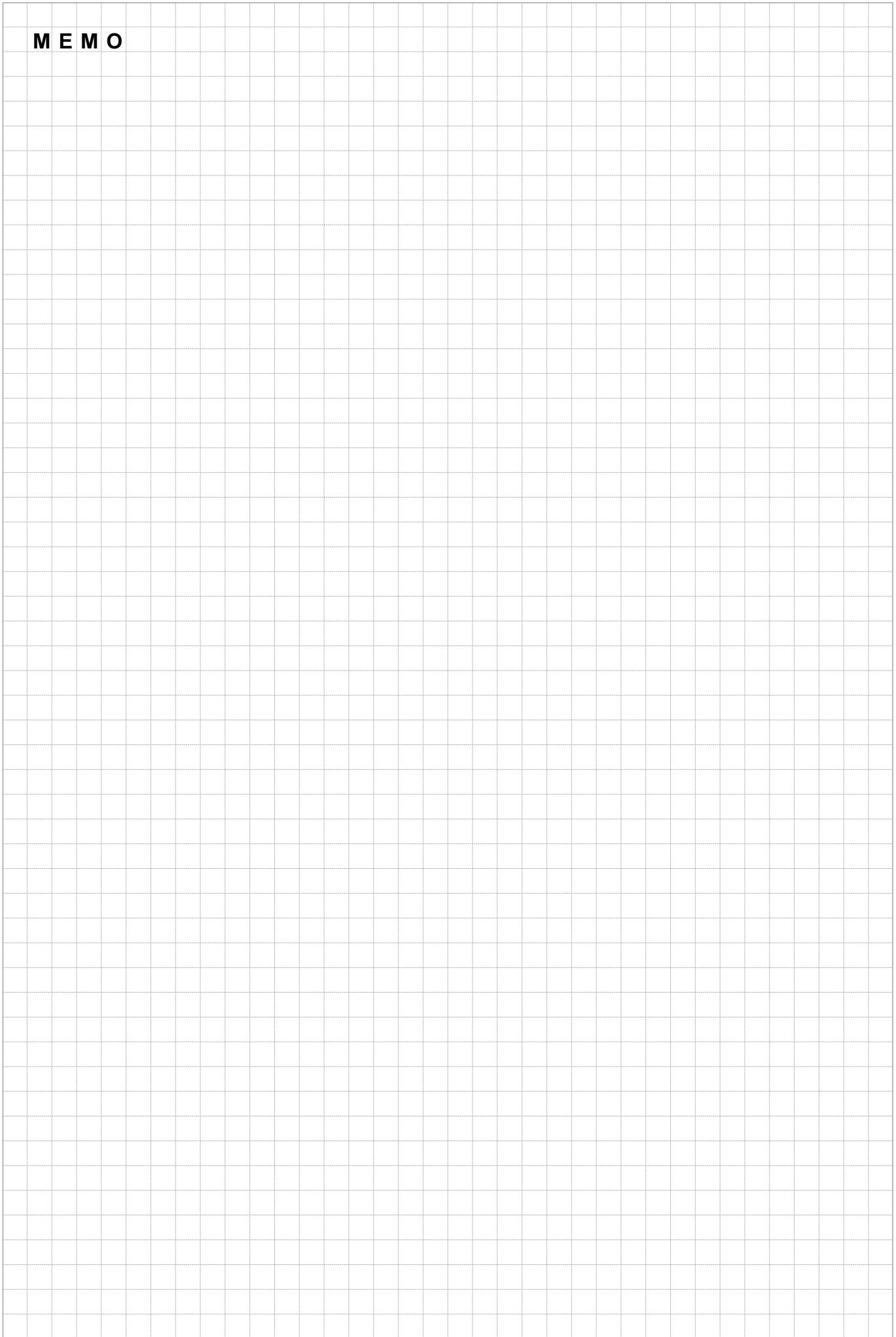

REDUCERS
Selection Tables
Ratio xxx - xxx

Selection Tables 6000 Series Reducer

Single Reduction Ratio 6 ~ 119 Frame Size: 6060 ~ 6120

Input Speed	$n_1 = 1750$ r/min	n_1 : Input Speed [r/min]	T_{out} : Allowable output torque [N·m, kgf·m]
		n_2 : Output Speed [r/min]	Pro: Allowable output shaft radial load [N, kgf]
		P_i : Allowable input power [kW]	*Consult us for Pro of CNF and CHF type.

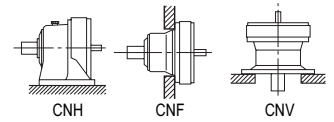

Selection Tables
Ratio 6 - 119
REDUCERS

Frame Size	n_2 [r/min] Ratio[Z]	292	219	159	135	117	103	83.3	70.0	60.3	50.0	40.7	34.3	29.7	24.6	20.1	14.7	Dim. Page
		6	8	11	13	15	17	21	25	29	35	43	51	59	71	87	119	
6060	P_i [kW]	0.200	0.200	0.200	0.200	0.200	0.200	0.200	0.110	0.110	0.110	0.090	-	-	-	-	-	CNH C-71 CNF C-76 CNV C-82
	T_{out} [N·m]	6.22	8.29	11.4	13.5	15.6	17.6	21.8	14.3	16.5	20.0	20.1	-	-	-	-	-	
	T_{out} [kgf·m]	0.634	0.845	1.16	1.38	1.59	1.79	2.22	1.46	1.68	2.04	2.05	-	-	-	-	-	
	Pro[N]	751	859	1170	1180	1180	1180	1180	1180	1180	1180	1180	-	-	-	-	-	
	Pro[kgf]	76.6	88	119	120	120	120	120	120	120	120	120	-	-	-	-	-	
6065	P_i [kW]	0.286	0.286	0.286	0.286	0.286	0.286	0.234	0.166	0.166	0.143	0.113	-	-	-	-	-	CNH C-71 CNF C-76 CNV C-82
	T_{out} [N·m]	8.91	11.9	16.3	19.3	22.3	25.2	25.4	21.5	24.9	26.0	25.2	-	-	-	-	-	
	T_{out} [kgf·m]	0.908	1.21	1.66	1.97	2.27	2.57	2.59	2.19	2.54	2.65	2.57	-	-	-	-	-	
	Pro[N]	747	852	1150	1180	1180	1180	1180	1180	1180	1180	1180	-	-	-	-	-	
	Pro[kgf]	76.1	86.9	117	120	120	120	120	120	120	120	120	-	-	-	-	-	
6070	P_i [kW]	0.347	0.347	0.347	0.347	0.347	0.347	0.320	0.230	0.226	0.211	0.170	0.100	0.100	-	-	-	CNH C-71 CNF C-76 CNV C-82
	T_{out} [N·m]	10.8	14.4	19.8	23.4	27.0	30.5	34.9	29.8	34.0	38.3	37.8	26.4	30.6	-	-	-	
	T_{out} [kgf·m]	1.10	1.47	2.02	2.39	2.75	3.11	3.56	3.04	3.47	3.90	3.85	2.69	3.12	-	-	-	
	Pro[N]	1300	1430	1600	1690	1690	1770	1770	1770	1770	1770	1770	1770	1770	-	-	-	
	Pro[kgf]	133	146	163	172	172	180	180	180	180	180	180	180	180	-	-	-	
6075	P_i [kW]	0.407	0.407	0.407	0.407	0.407	0.407	0.407	0.294	0.286	0.279	0.226	0.143	0.136	-	-	-	CNH C-71 CNF C-76 CNV C-82
	T_{out} [N·m]	12.7	16.9	23.2	27.4	31.6	35.9	44.3	38.1	43.0	50.6	50.4	37.9	41.5	-	-	-	
	T_{out} [kgf·m]	1.29	1.72	2.36	2.79	3.22	3.66	4.52	3.88	4.38	5.16	5.14	3.86	4.23	-	-	-	
	Pro[N]	1290	1420	1590	1670	1680	1770	1770	1770	1770	1770	1770	1770	1770	-	-	-	
	Pro[kgf]	131	145	162	170	171	180	180	180	180	180	180	180	180	-	-	-	
6080	P_i [kW]	0.592	0.592	0.592	0.592	0.592	0.592	0.478	0.340	0.340	0.329	0.250	0.192	0.185	0.120	0.090	-	CNH C-71 CNF C-76 CNV C-82
	T_{out} [N·m]	18.4	24.6	33.8	39.9	46.1	52.2	52.1	44.1	51.1	61.7	55.7	50.8	56.5	44.2	40.6	-	
	T_{out} [kgf·m]	1.88	2.51	3.45	4.07	4.70	5.32	5.31	4.50	5.21	6.29	5.68	5.18	5.76	4.51	4.14	-	
	Pro[N]	1800	1940	2140	2300	2370	2480	2440	2530	2560	2560	2560	2560	2560	2560	2560	2560	
	Pro[kgf]	183	198	218	234	242	253	249	258	261	261	261	261	261	261	261	-	
6085	P_i [kW]	0.778	0.778	0.778	0.778	0.778	0.778	0.550	0.475	0.467	0.371	0.294	0.241	0.234	0.187	0.121	-	CNH C-71 CNF C-76 CNV C-82
	T_{out} [N·m]	24.2	32.3	44.4	52.4	60.5	68.5	59.9	61.5	70.2	84.8	65.5	63.7	71.4	74.4	54.7	-	
	T_{out} [kgf·m]	2.47	3.29	4.53	5.34	6.17	6.98	6.11	6.27	7.16	8.64	6.68	6.49	7.28	7.58	5.58	-	
	Pro[N]	1790	1930	2120	2280	2350	2450	2430	2500	2550	2560	2560	2560	2560	2560	2560	2560	
	Pro[kgf]	182	197	216	232	240	250	248	255	260	261	261	261	261	255	261	-	
6090	P_i [kW]	1.15	1.15	1.15	1.15	1.15	1.15	0.758	0.671	0.625	0.612	0.435	0.332	0.309	0.252	0.211	0.125	CNH C-71 CNF C-76 CNV C-82
	T_{out} [N·m]	35.7	47.5	65.4	77.3	89.1	101	82.5	86.9	94.0	111	97.0	87.7	94.5	92.6	95.3	77.1	
	T_{out} [kgf·m]	3.64	4.84	6.67	7.88	9.08	10.3	8.41	8.86	9.58	11.3	9.89	8.94	9.63	9.44	9.71	7.86	
	Pro[N]	2650	2950	3340	3340	3340	3340	3340	3340	3340	3340	3340	3340	3340	3340	3340	3340	
	Pro[kgf]	270	301	340	340	340	340	340	340	340	340	340	340	340	340	340	340	
6095	P_i [kW]	1.52	1.52	1.52	1.52	1.52	1.52	0.866	0.784	0.758	0.603	0.422	0.373	0.301	0.301	0.151	-	CNH C-71 CNF C-76 CNV C-82
	T_{out} [N·m]	47.1	62.8	86.4	102	118	134	165	112	118	137	134	112	114	111	136	93.0	
	T_{out} [kgf·m]	4.80	6.40	8.81	10.4	12.0	13.7	16.8	11.4	12.0	14.0	13.7	11.4	11.6	11.3	13.9	9.48	
	Pro[N]	2630	2910	3300	3300	3280	3290	3260	3340	3340	3320	3340	3340	3340	3340	3340	3340	
	Pro[kgf]	268	297	336	336	334	335	332	340	340	338	340	340	340	340	340	340	
6100	P_i [kW]	2.35	2.35	2.35	2.35	2.35	1.99	1.93	1.27	1.21	0.975	0.780	0.560	0.516	0.436	0.433	0.210	CNH C-71 CNF C-76 CNV C-82
	T_{out} [N·m]	73.0	97.4	134	158	183	175	210	165	182	177	174	148	158	160	195	130	
	T_{out} [kgf·m]	7.44	9.93	13.7	16.1	18.7	17.8	21.4	16.8	18.6	18.0	17.7	15.1	16.1	16.3	19.9	13.3	
	Pro[N]	3850	4290	4860	5050	5330	5400	5400	5400	5400	5400	5400	5400	5400	5400	5400	5400	
	Pro[kgf]	392	437	495	515	543	550	550	550	550	550	550	550	550	550	550	550	
6105	P_i [kW]	3.18	3.18	3.18	3.18	3.18	2.46	2.34	1.67	1.59	1.20	1.08	0.776	0.708	0.561	0.565	0.286	CNH C-71 CNF C-76 CNV C-82
	T_{out} [N·m]	98.9	132	181	214	247	216	254	217	239	217	242	205	217	207	255	177	
	T_{out} [kgf·m]	10.1	13.5	18.5	21.8	25.2	22.0	25.9	22.1	24.4	22.1	24.7	20.9	22.1	21.1	26.0	18.0	
	Pro[N]	3820	4240	4800	4980	5250	5380	5380	5380	5380	5380	5380	5380	5380	5380	5400	5400	
	Pro[kgf]	389	432	489	508	535	548	548	548	548	548	548	548	548	550	550	550	
6110	P_i [kW]	3.55	3.55	3.55	3.55	3.55	3.18	2.72	1.91	1.90	1.50	1.30	0.944	0.859	0.669	0.661	-	CNH C-71 CNF C-76 CNV C-82
	T_{out} [N·m]	110	147	202	239	276	280	297	248	286	273	290	249	263	246	298	-	
	T_{out} [kgf·m]	11.2	15.0	20.6	24.4	28.1	28.5	30.3	25.3	29.2	27.8	29.6	25.4	26.8	25.1	30.4	-	
	Pro[N]	4320	4810	5470	5650	6010	6090	6470	6660	6840	7360	7610	7610	7610	7610	7610	7610	
	Pro[kgf]	440	490	558	576	613	621	660	679	697	750	776	776	776	776	776	-	
6115	P_i [kW]	3.92	3.92	3.92	3.90	3.90	3.90	3.11	2.22	2.22	1.81	1.52	1.11	1.01	0.758	0.758	-	CNH C-71 CNF C-76 CNV C-82
	T_{out} [N·m]	122	163	223	263	303	344	339	288	334	328	338	294	309	279	342	-	
	T_{out} [kgf·m]	12.4	16.6	22.7	26.8	30.9	35.1	34.6	29.4	34.0	33.4	34.5	30.0	31.5	28.4	34.9	-	
	Pro[N]	4310	4790	5450	5620	5970	6020	6430	6620	6800	7310	7610	7610	7610	7610	7610	7610	
	Pro[kgf]	439	488	556	573	609	614	655	675	693	745	776	776	776	776	776	-	
6120	P_i [kW]	5.07	5.07	5.07	5.07	5.07	5.07	3.96	3.09	2.99	2.49	1.91	1.72	1.30	0.957	0.944	-	CNH C-71 CNF C-76 CNV C-82
	T_{out} [N·m]	158	210	289	342	394	447	431	400	450	453	427	454	399	352	426	-	
	T_{out} [kgf·m]	16.1	21.4	29.5	34.9	40.2	45.6	43.9	40.8	45.9	46.2	43.5	46.3	40.7	35.9	43.4	-	
	Pro[N]	4860	5410	6130	6310	6760	6810	7540	7970	8280	8790	9430	9810	9810	9810	9810	9810	
	Pro[kgf]	495	551	625	643	689	694	769	812	844	896	961	1000	1000	1000	1000	-	
Frame Size	Ratio[Z]	6	8	11	13	15	17	21	25	29	35	43	51	59	71	87	119	Dim. Page
	n_2 [r/min]	292	219	159	135	117	103	83.3	70.0	60.3	50.0	40.7	34.3	29.7	24.6	20.1	14.7	

Note: 1. Allowable radial load Pro is the value at the midpoint of the output shaft. Refer to pages F-11~12 when radial load is off the midpoint of output shaft and for checking thrust load.

2. Refer to pages F-15~16 for allowable radial load for input shaft.

Selection Tables 6000 Series Reducer

Single Reduction Ratio 6 ~ 119 Frame Size: 6125 ~ 6195

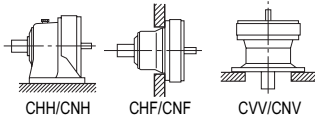

n_1 : Input Speed [r/min] T_{out} : Allowable output torque [N·m, kgf·m]
 n_2 : Output Speed [r/min] Pro: Allowable output shaft radial load [N, kgf]
 P_1 : Allowable input power [kW] *Consult us for Pro of CNF and CHF type.

Input Speed $n_1 = 1750$ r/min

Frame Size	n_2 [r/min] Ratio[Z]	292	219	159	135	117	103	83.3	70.0	60.3	50.0	40.7	34.3	29.7	24.6	20.1	14.7	Dim. Page
6125	P_1 [kW]	5.81	6.95	5.92	5.92	5.92	5.66	4.88	3.96	3.77	3.18	2.38	2.28	1.62	1.20	1.13	-	- CNH C-71 CNF C-76 CNV C-82
	T_{out} [N·m]	181	288	338	399	460	499	532	513	566	577	531	602	495	441	510	-	
	T_{out} [kgf·m]	18.5	29.4	34.5	40.7	46.9	50.9	54.2	52.3	57.7	58.8	54.1	61.4	50.5	45.0	52.0	-	
	Pro[N]	4840	5340	6080	6250	6700	6760	7450	7870	8170	8670	9340	9740	9790	9790	9810	-	
	Pro[kgf]	493	544	620	637	683	689	759	802	833	884	952	993	998	998	1000	-	
6130	P_1 [kW]	9.39	9.39	9.39	9.39	7.78	7.27	6.14	5.16	4.48	3.71	2.99	2.54	2.19	1.83	1.42	-	- CHH C-72 CHF C-77 CVV C-83
	T_{out} [N·m]	292	389	535	633	605	641	669	669	674	673	668	672	669	674	640	-	
	T_{out} [kgf·m]	29.8	39.7	54.5	64.5	61.7	65.3	68.2	68.2	68.7	68.6	68.1	68.5	68.2	68.7	65.2	-	
	Pro[N]	5590	6210	7060	7330	7550	8120	8710	9100	9610	10200	11000	11500	12100	12900	13900	-	
	Pro[kgf]	570	633	720	747	770	828	888	928	980	1040	1120	1170	1230	1310	1420	-	
6135	P_1 [kW]	11.3	11.3	11.3	11.3	8.97	8.29	7.53	5.95	5.64	4.25	3.77	2.93	2.52	2.17	1.91	-	- CHH C-72 CHF C-77 CVV C-83
	T_{out} [N·m]	352	469	645	762	697	730	820	771	848	771	840	775	772	799	861	-	
	T_{out} [kgf·m]	35.9	47.8	65.7	77.7	71.0	74.4	83.6	78.6	86.4	78.6	85.6	79.0	78.7	81.4	87.8	-	
	Pro[N]	5520	6140	6970	7230	7480	8050	8590	9030	9480	10100	10800	11400	12000	12800	13800	-	
	Pro[kgf]	563	626	710	737	762	821	876	920	966	1030	1100	1160	1220	1300	1410	-	
6140	P_1 [kW]	13.0	13.0	13.0	13.0	12.0	10.1	8.66	6.89	5.95	5.21	3.94	3.43	2.96	2.43	1.98	-	- CHH C-72 CHF C-77 CVV C-83
	T_{out} [N·m]	405	540	743	878	933	888	943	893	895	945	879	906	905	895	893	-	
	T_{out} [kgf·m]	41.3	55.0	75.7	89.5	95.1	90.5	96.1	91.0	91.2	96.3	89.6	92.4	92.3	91.2	91.0	-	
	Pro[N]	8750	9690	10900	11100	11600	12200	13000	13700	14000	15100	15800	16000	16000	16000	16000	-	
	Pro[kgf]	892	988	1110	1130	1180	1240	1330	1400	1430	1540	1610	1630	1630	1630	1630	-	
6145	P_1 [kW]	15.1	15.1	15.1	15.1	15.1	12.0	11.0	7.91	7.53	7.53	5.39	4.22	3.65	3.03	2.48	-	- CHH C-72 CHF C-77 CVV C-83
	T_{out} [N·m]	471	628	864	1020	1170	1060	1190	1030	1130	1370	1200	1120	1120	1110	1120	-	
	T_{out} [kgf·m]	48.0	64.0	88.1	104	119	108	121	105	115	140	122	114	114	113	114	-	
	Pro[N]	8720	9650	10800	11000	11500	12100	12900	13700	14000	14900	15600	16000	16000	16000	16000	-	
	Pro[kgf]	889	984	1100	1120	1170	1230	1310	1400	1430	1520	1590	1630	1630	1630	1630	-	
6160	P_1 [kW]	20.3	19.7	19.7	19.7	18.7	13.1	12.9	9.86	10.5	9.67	7.45	5.75	4.42	3.47	3.47	-	- CHH C-72 CHF C-77 CVV C-84
	T_{out} [N·m]	631	817	1120	1330	1460	1150	1400	1280	1580	1760	1660	1520	1350	1280	1570	-	
	T_{out} [kgf·m]	64.3	83.3	114	136	149	117	143	130	161	179	169	155	138	130	160	-	
	Pro[N]	9550	10700	12000	12500	13300	14000	14900	15800	16300	17300	18700	19600	21900	22000	21800	-	
	Pro[kgf]	973	1090	1220	1270	1360	1430	1520	1610	1660	1760	1910	2000	2230	2240	2220	-	
6165	P_1 [kW]	24.1	24.1	24.1	22.6	22.6	18.8	16.1	15.1	11.4	11.4	7.91	7.53	5.75	5.65	3.90	-	- CHH C-72 CHF C-77 CVV C-84
	T_{out} [N·m]	748	997	1370	1520	1760	1660	1750	1950	1720	2070	1760	1990	1760	2080	1760	-	
	T_{out} [kgf·m]	76.2	102	140	155	179	169	178	199	175	211	179	203	179	212	179	-	
	Pro[N]	9460	10500	11900	12400	13100	13600	14700	15300	16200	17100	18600	19300	21700	21500	21700	-	
	Pro[kgf]	964	1070	1210	1260	1340	1390	1500	1560	1650	1740	1900	1970	2210	2190	2210	-	
6170	P_1 [kW]	27.6	27.6	27.6	27.3	25.5	19.7	19.5	15.8	14.3	12.0	9.75	8.39	7.15	5.92	4.81	-	- CHH C-72 CHF C-77 CVV C-84
	T_{out} [N·m]	859	1140	1570	1840	1980	1730	2120	2050	2150	2180	2170	2220	2190	2180	2170	-	
	T_{out} [kgf·m]	87.6	116	160	188	202	176	216	209	219	222	221	226	223	222	221	-	
	Pro[N]	10700	11800	13500	14000	14600	15500	16700	17500	18400	19600	21000	22000	23200	24600	26500	-	
	Pro[kgf]	1090	1200	1380	1430	1490	1580	1700	1780	1880	2000	2140	2240	2360	2510	2700	-	
6175	P_1 [kW]	30.1	30.1	30.1	30.1	30.1	24.1	24.1	19.5	18.8	15.1	11.3	11.3	8.29	7.15	5.62	-	- CHH C-72 CHF C-77 CVV C-84
	T_{out} [N·m]	937	1250	1720	2030	2340	2120	2620	2530	2830	2730	2520	2990	2540	2630	2540	-	
	T_{out} [kgf·m]	95.5	127	175	207	239	216	267	258	288	278	257	305	259	268	259	-	
	Pro[N]	10700	11700	13400	13900	14400	15300	16400	17200	18100	19300	20900	21600	23000	24400	26300	-	
	Pro[kgf]	1090	1190	1370	1420	1470	1560	1670	1750	1850	1970	2130	2200	2340	2490	2680	-	
6180	P_1 [kW]	-	-	35.2	35.2	32.4	30.6	30.0	24.1	19.5	18.8	15.1	12.0	9.75	8.80	7.15	-	- CHH C-72 CHF C-77 CVV C-84
	T_{out} [N·m]	-	-	2010	2370	2520	2690	3270	3120	2930	3410	3360	3170	2980	3240	3220	-	
	T_{out} [kgf·m]	-	-	205	242	257	274	333	318	299	348	343	323	304	330	328	-	
	Pro[N]	-	-	18000	18700	19700	20800	22400	23400	24600	26300	28300	29500	31000	33000	35600	-	
	Pro[kgf]	-	-	1830	1910	2010	2120	2280	2390	2510	2680	2880	3010	3160	3360	3630	-	
6185	P_1 [kW]	-	-	39.0	39.0	39.0	39.0	39.0	30.1	24.1	22.6	18.8	15.1	12.0	9.79	8.59	-	- CHH C-72 CHF C-77 CVV C-84
	T_{out} [N·m]	-	-	2220	2630	3030	3440	4250	3910	3620	4100	4200	3980	3670	3610	3870	-	
	T_{out} [kgf·m]	-	-	226	268	309	351	433	399	369	418	428	406	374	368	394	-	
	Pro[N]	-	-	17900	18600	19500	20500	22000	23100	24400	26000	27900	29200	30700	32800	35400	-	
	Pro[kgf]	-	-	1820	1900	1990	2090	2240	2350	2490	2650	2840	2980	3130	3340	3610	-	
6190	P_1 [kW]	-	-	41.0	41.0	41.0	41.0	41.0	35.2	30.7	24.3	20.9	18.2	15.3	13.5	11.8	-	- CHH C-72 CHF C-77 CVV C-84
	T_{out} [N·m]	-	-	2340	2760	3190	3610	4460	4560	4620	4410	4670	4810	4670	4980	5320	-	
	T_{out} [kgf·m]	-	-	239	281	325	368	455	465	471	450	476	490	476	508	542	-	
	Pro[N]	-	-	25300	26300	27500	29000	31200	32800	34500	36600	39500	41300	43400	46000	49600	-	
	Pro[kgf]	-	-	2580	2680	2800	2960	3180	3340	3520	3730	4030	4210	4420	4690	5060	-	
6195	P_1 [kW]	-	-	48.1	48.1	48.1	48.1	48.1	40.5	37.8	30.1	30.1	20.9	18.8	15.6	13.6	-	- CHH C-72 CHF C-77 CVV C-84
	T_{out} [N·m]	-	-	2740	3240	3740	4240	5240	5240	5680	5470	6720	5540	5760	5740	6150	-	
	T_{out} [kgf·m]	-	-	279	330	381	432	534	534	579	558	685	565	587	585	627	-	
	Pro[N]	-	-	25200	26100	27300	28800	31000	32600	34200	36300	38900	41100	43100	45800	49400	-	
	Pro[kgf]	-	-	2570	2660	2780												

Selection Tables 6000 Series Reducer

Single Reduction Ratio 6 ~ 119 Frame Size: 6205 ~ 6275

Input Speed	$n_1 = 1750$ r/min	n_1 : Input Speed [r/min]	T_{out} : Allowable output torque [N·m, kgf·m]
		n_2 : Output Speed [r/min]	Pro: Allowable output shaft radial load [N, kgf]
		P_1 : Allowable input power [kW]	*Consult us for Pro of CNF and CHF type.

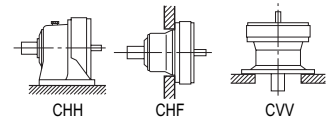

Selection Tables
Ratio 6 - 119
REDUCERS

Frame Size	n_2 [r/min] Ratio[Z]	292	219	159	135	117	103	83.3	70.0	60.3	50.0	40.7	34.3	29.7	24.6	20.1	14.7	Dim. Page
		6	8	11	13	15	17	21	25	29	35	43	51	59	71	87	119	
6205	P_1 [kW]	-	-	59.7	-	59.7	-	59.2	-	45.7	-	31.8	-	22.6	-	15.9	-	CHH C-72 CHF C-77 CVW C-84
	T_{out} [N·m]	-	-	3400	-	4640	-	6450	-	6860	-	7090	-	6910	-	7170	-	
	T_{out} [kgf·m]	-	-	347	-	473	-	657	-	699	-	723	-	704	-	731	-	
	Pro [N]	-	-	48900	-	52500	-	58600	-	64100	-	72500	-	79200	-	84100	-	
	Pro [kgf]	-	-	4980	-	5350	-	5970	-	6530	-	7390	-	8070	-	8570	-	
6215	P_1 [kW]	-	-	75.3	-	75.3	-	75.3	-	58.5	-	45.2	-	37.7	-	21.4	-	CHH C-72 CHF C-77 CVW C-84
	T_{out} [N·m]	-	-	4300	-	5860	-	8200	-	8790	-	10100	-	11500	-	9650	-	
	T_{out} [kgf·m]	-	-	438	-	597	-	836	-	896	-	1030	-	1170	-	984	-	
	Pro [N]	-	-	49300	-	52900	-	59500	-	64900	-	73300	-	79700	-	90300	-	
	Pro [kgf]	-	-	5030	-	5390	-	6070	-	6620	-	7470	-	8120	-	9200	-	
6225	P_1 [kW]	-	-	99.5	-	99.5	-	94.2	-	75.3	-	56.5	-	45.2	-	26.7	-	CHH C-72 CHF C-77 CVW C-84
	T_{out} [N·m]	-	-	5670	-	7730	-	10300	-	11300	-	12600	-	13800	-	12100	-	
	T_{out} [kgf·m]	-	-	578	-	788	-	1050	-	1150	-	1280	-	1410	-	1230	-	
	Pro [N]	-	-	52100	-	56100	-	62500	-	68200	-	77200	-	84100	-	95200	-	
	Pro [kgf]	-	-	5310	-	5720	-	6370	-	6950	-	7870	-	8570	-	9700	-	
6235	P_1 [kW]	-	-	-	-	-	-	-	-	-	-	-	-	-	-	-	-	
	T_{out} [N·m]	-	-	-	-	-	-	-	-	-	-	-	-	-	-	-	-	
	T_{out} [kgf·m]	-	-	-	-	-	-	-	-	-	-	-	-	-	-	-	-	
	Pro [N]	-	-	-	-	-	-	-	-	-	-	-	-	-	-	-	-	
	Pro [kgf]	-	-	-	-	-	-	-	-	-	-	-	-	-	-	-	-	
6245	P_1 [kW]	-	-	-	-	-	-	-	-	-	-	-	-	-	-	-	-	
	T_{out} [N·m]	-	-	-	-	-	-	-	-	-	-	-	-	-	-	-	-	
	T_{out} [kgf·m]	-	-	-	-	-	-	-	-	-	-	-	-	-	-	-	-	
	Pro [N]	-	-	-	-	-	-	-	-	-	-	-	-	-	-	-	-	
	Pro [kgf]	-	-	-	-	-	-	-	-	-	-	-	-	-	-	-	-	
6255	P_1 [kW]	-	-	-	-	-	-	-	-	-	-	-	-	-	-	-	-	
	T_{out} [N·m]	-	-	-	-	-	-	-	-	-	-	-	-	-	-	-	-	
	T_{out} [kgf·m]	-	-	-	-	-	-	-	-	-	-	-	-	-	-	-	-	
	Pro [N]	-	-	-	-	-	-	-	-	-	-	-	-	-	-	-	-	
	Pro [kgf]	-	-	-	-	-	-	-	-	-	-	-	-	-	-	-	-	
6265	P_1 [kW]	-	-	-	-	-	-	-	-	-	-	-	-	-	-	-	-	
	T_{out} [N·m]	-	-	-	-	-	-	-	-	-	-	-	-	-	-	-	-	
	T_{out} [kgf·m]	-	-	-	-	-	-	-	-	-	-	-	-	-	-	-	-	
	Pro [N]	-	-	-	-	-	-	-	-	-	-	-	-	-	-	-	-	
	Pro [kgf]	-	-	-	-	-	-	-	-	-	-	-	-	-	-	-	-	
6275	P_1 [kW]	-	-	-	-	-	-	-	-	-	-	-	-	-	-	-	-	
	T_{out} [N·m]	-	-	-	-	-	-	-	-	-	-	-	-	-	-	-	-	
	T_{out} [kgf·m]	-	-	-	-	-	-	-	-	-	-	-	-	-	-	-	-	
	Pro [N]	-	-	-	-	-	-	-	-	-	-	-	-	-	-	-	-	
	Pro [kgf]	-	-	-	-	-	-	-	-	-	-	-	-	-	-	-	-	
Frame Size	n_2 [r/min]	292	219	159	135	117	103	83.3	70.0	60.3	50.0	40.7	34.3	29.7	24.6	20.1	14.7	Dim. Page

Note: 1. Allowable radial load Pro is the value at the midpoint of the output shaft. Refer to pages F-11~12 when radial load is off the midpoint of output shaft and for checking thrust load.
2. Refer to pages F-15~16 for allowable radial load for input shaft.

M E M O

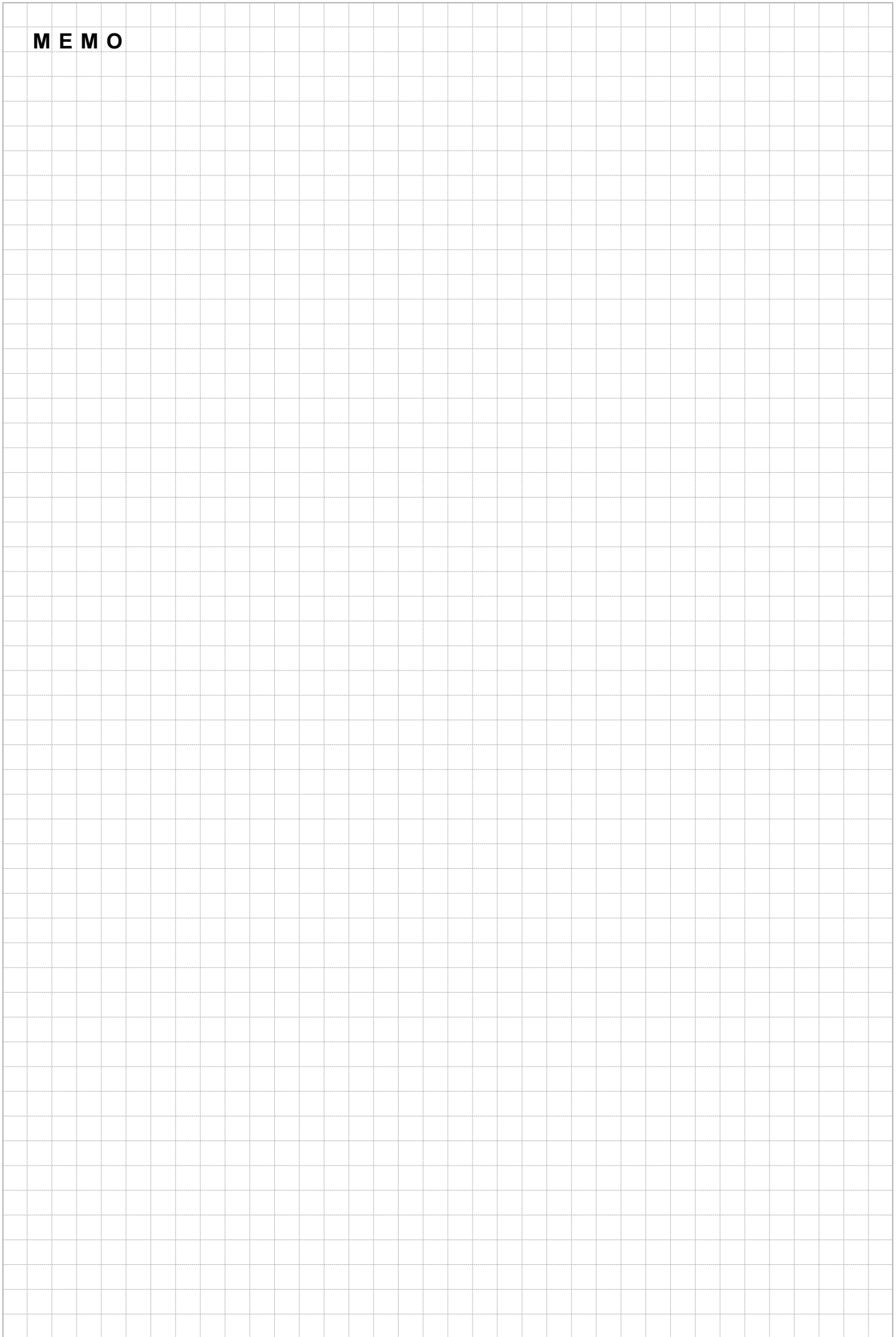

REDUCERS
Selection Tables
Ratio xxx - xxx

Selection Tables 6000 Series Reducer

Double Reduction Ratio 104,121 ~ 7569 Frame Size: 6060DA ~ 6130DA

Input Speed	$n_1 = 1450$ r/min	n_1 : Input Speed [r/min]	T_{out} : Allowable output torque [N·m, kgf·m]
		n_2 : Output Speed [r/min]	Pro: Allowable output shaft radial load [N, kgf]
		P_i : Allowable input power [kW]	*Consult us for Pro of CNF and CHF type.

Frame Size	n_2 [r/min]	13.9	12.0	10.1	8.79	7.44	6.28	5.31	4.55	3.85	3.07	2.59	2.23	1.98	1.72	
	Ratio[Z]	104	121	143	165	195	231	273	319	377	473	559	649	731	841	
6060DA	P_i [kW]	0.100	0.100	0.100	0.100	0.100	0.100	0.100	0.100	0.100	0.100	0.100	-	0.100	0.100	
	T_{out} [N·m]	24.0	24.0	24.0	24.0	24.0	24.0	24.0	24.0	24.0	24.0	24.0	-	24.0	24.0	
	T_{out} [kgf·m]	2.45	2.45	2.45	2.45	2.45	2.45	2.45	2.45	2.45	2.45	2.45	-	2.45	2.45	
	Pro [N]	1180	1180	1180	1180	1180	1180	1180	1180	1180	1180	1180	-	1180	1180	
	Pro [kgf]	120	120	120	120	120	120	120	120	120	120	120	-	120	120	
6065DA	P_i [kW]	0.100	0.100	0.100	0.100	0.100	0.100	0.100	0.100	0.100	0.100	0.100	-	0.100	0.100	
	T_{out} [N·m]	30.0	30.0	30.0	30.0	30.0	30.0	30.0	30.0	30.0	30.0	30.0	-	30.0	30.0	
	T_{out} [kgf·m]	3.06	3.06	3.06	3.06	3.06	3.06	3.06	3.06	3.06	3.06	3.06	-	3.06	3.06	
	Pro [N]	1180	1140	1180	1180	1180	1180	1180	1180	1180	1180	1180	-	1180	1180	
	Pro [kgf]	120	116	120	120	120	120	120	120	120	120	120	-	120	120	
6070DA	P_i [kW]	0.100	0.100	0.100	0.100	0.100	0.100	0.100	0.100	0.100	0.100	0.100	0.100	0.100	0.100	
	T_{out} [N·m]	45.0	45.0	45.0	45.0	45.0	45.0	45.0	45.0	45.0	45.0	45.0	45.0	45.0	45.0	
	T_{out} [kgf·m]	4.59	4.59	4.59	4.59	4.59	4.59	4.59	4.59	4.59	4.59	4.59	4.59	4.59	4.59	
	Pro [N]	1770	1770	1770	1770	1770	1770	1770	1770	1770	1770	1770	1770	1770	1770	
	Pro [kgf]	180	180	180	180	180	180	180	180	180	180	180	180	180	180	
6075DA	P_i [kW]	0.100	0.100	0.100	0.100	0.100	0.100	0.100	0.100	0.100	0.100	0.100	0.100	0.100	0.100	
	T_{out} [N·m]	60.0	50.8	60.0	60.0	60.0	60.0	60.0	60.0	60.0	60.0	60.0	57.4	60.0	60.0	
	T_{out} [kgf·m]	6.12	5.18	6.12	6.12	6.12	6.12	6.12	6.12	6.12	6.12	6.12	5.85	6.12	6.12	
	Pro [N]	1770	1770	1770	1770	1770	1770	1770	1770	1770	1770	1660	1660	1580	1660	1770
	Pro [kgf]	180	180	180	180	180	180	180	180	180	180	169	169	161	169	180
6090DA	P_i [kW]	0.243	0.209	0.177	0.153	0.130	0.110	0.100	0.100	0.100	0.100	0.100	0.100	0.100	0.100	
	T_{out} [N·m]	150	150	150	150	150	150	150	150	150	150	150	146	150	150	
	T_{out} [kgf·m]	15.3	15.3	15.3	15.3	15.3	15.3	15.3	15.3	15.3	15.3	15.3	14.9	15.3	15.3	
	Pro [N]	3340	3340	3340	3340	3340	3340	3340	3290	3290	3310	3310	3300	3310	3290	
	Pro [kgf]	340	340	340	340	340	340	340	336	336	338	338	336	338	336	
6095DA	P_i [kW]	0.293	0.224	0.216	0.204	0.173	0.146	0.124	0.106	0.100	0.100	0.100	-	0.100	0.100	
	T_{out} [N·m]	181	160	183	200	200	200	200	200	200	200	200	-	200	200	
	T_{out} [kgf·m]	18.4	16.4	18.7	20.4	20.4	20.4	20.4	20.4	20.4	20.4	20.4	-	20.4	20.4	
	Pro [N]	3340	3340	3340	3340	3340	3340	3340	3200	3200	3220	3220	-	3220	3200	
	Pro [kgf]	340	340	340	340	340	340	340	326	326	328	328	-	328	326	
6100DA	P_i [kW]	0.406	0.349	0.295	0.256	0.216	0.183	0.154	0.132	0.112	0.100	0.100	0.100	0.100	0.100	
	T_{out} [N·m]	250	250	250	250	250	250	250	250	250	250	250	250	250	250	
	T_{out} [kgf·m]	25.5	25.5	25.5	25.5	25.5	25.5	25.5	25.5	25.5	25.5	25.5	25.5	25.5	25.5	
	Pro [N]	5400	5400	5400	5400	5400	5400	5400	5400	5400	5400	5400	5400	5400	5400	
	Pro [kgf]	550	550	550	550	550	550	550	550	550	550	550	550	550	550	
6105DA	P_i [kW]	0.429	0.429	0.354	0.307	0.260	0.219	0.185	0.159	0.134	0.107	0.100	0.100	0.100	0.100	
	T_{out} [N·m]	265	308	300	300	300	300	300	300	300	300	300	296	300	300	
	T_{out} [kgf·m]	27.0	31.4	30.6	30.6	30.6	30.6	30.6	30.6	30.6	30.6	30.6	30.2	30.6	30.6	
	Pro [N]	5400	5400	5400	5400	5400	5400	5400	5400	5400	5400	5400	5090	5400	5400	
	Pro [kgf]	550	550	550	550	550	550	550	550	550	550	550	519	550	550	
6120DA	P_i [kW]	-	-	0.429	0.429	0.429	0.381	0.322	0.275	0.233	0.187	0.158	0.136	0.121	0.104	
	T_{out} [N·m]	-	-	364	420	496	522	522	520	520	525	525	525	525	520	
	T_{out} [kgf·m]	-	-	37.1	42.8	50.6	53.2	53.2	53.0	53.0	53.5	53.5	53.5	53.5	53.0	
	Pro [N]	-	-	9810	9810	9810	9810	9810	9810	9810	9810	9810	9810	9810	9810	
	Pro [kgf]	-	-	1000	1000	1000	1000	1000	1000	1000	1000	1000	1000	1000	1000	
6120DB	P_i [kW]	0.852	0.732	0.619	0.537	0.454	0.381	-	-	-	-	-	-	-	-	
	T_{out} [N·m]	525	525	525	525	525	522	-	-	-	-	-	-	-	-	
	T_{out} [kgf·m]	53.5	53.5	53.5	53.5	53.5	53.2	-	-	-	-	-	-	-	-	
	Pro [N]	9810	9810	9810	9810	9810	9810	-	-	-	-	-	-	-	-	
	Pro [kgf]	1000	1000	1000	1000	1000	1000	-	-	-	-	-	-	-	-	
6125DA	P_i [kW]	-	-	-	-	-	0.429	0.389	0.333	0.282	0.225	0.190	0.164	0.145	0.126	
	T_{out} [N·m]	-	-	-	-	-	588	630	630	630	630	630	630	630	630	
	T_{out} [kgf·m]	-	-	-	-	-	59.9	64.2	64.2	64.2	64.2	64.2	64.2	64.2	64.2	
	Pro [N]	-	-	-	-	-	9810	9810	9810	9810	9810	9810	9810	9810	9810	
	Pro [kgf]	-	-	-	-	-	1000	1000	1000	1000	1000	1000	1000	1000	1000	
6125DB	P_i [kW]	1.02	0.867	0.743	0.644	0.545	0.460	0.389	0.333	-	-	-	-	-	-	
	T_{out} [N·m]	630	622	630	630	630	630	630	630	-	-	-	-	-	-	
	T_{out} [kgf·m]	64.2	63.4	64.2	64.2	64.2	64.2	64.2	64.2	-	-	-	-	-	-	
	Pro [N]	9810	9810	9810	9810	9810	9810	9810	9810	-	-	-	-	-	-	
	Pro [kgf]	1000	1000	1000	1000	1000	1000	1000	1000	-	-	-	-	-	-	
6130DA	P_i [kW]	-	-	-	-	-	-	0.429	0.413	0.349	0.278	0.235	0.237	0.200	0.200	
	T_{out} [N·m]	-	-	-	-	-	-	695	780	780	780	780	912	780	780	
	T_{out} [kgf·m]	-	-	-	-	-	-	70.8	79.5	79.5	79.5	79.5	93.0	79.5	79.5	
	Pro [N]	-	-	-	-	-	-	14700	14700	14700	14700	14700	14700	14700	14700	
	Pro [kgf]	-	-	-	-	-	-	1500	1500	1500	1500	1500	1500	1500	1500	

Note: 1. Allowable radial load Pro is the value at the midpoint of the output shaft. Refer to pages F-11~12 when radial load is off the midpoint of output shaft and for checking thrust load.
2. Refer to pages F-15~16 for allowable radial load for input shaft.

Selection Tables
Ratio 104,121 ~ 7569
REDUCERS

Selection Tables 6000 Series Reducer

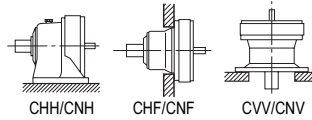

Input Speed	$n_1 = 1450$ r/min
-------------	--------------------

1.45	1.16	0.980	0.784	0.702	0.572	0.476	0.417	0.327	0.282	0.235	0.192	n_2 [r/min]	Dim. Page	Frame Size
1003	1247	1479	1849	2065	2537	3045	3481	4437	5133	6177	7569	Ratio[Z]		
-	0.100	-	0.100	-	-	-	-	-	-	-	-	P_i [kW]	CNH C-73 CNF C-78 CNV C-85	6060DA
-	24.0	-	24.0	-	-	-	-	-	-	-	-	T_{OUT} [N•m]		
-	2.45	-	2.45	-	-	-	-	-	-	-	-	T_{OUT} [kgf•m]		
-	1180	-	1180	-	-	-	-	-	-	-	-	Prof[N]		
-	120	-	120	-	-	-	-	-	-	-	-	Prof[kgf]		
-	0.100	-	0.100	-	-	-	-	-	-	-	-	P_i [kW]	CNH C-73 CNF C-78 CNV C-85	6065DA
-	30.0	-	30.0	-	-	-	-	-	-	-	-	T_{OUT} [N•m]		
-	3.06	-	3.06	-	-	-	-	-	-	-	-	T_{OUT} [kgf•m]		
-	1180	-	1180	-	-	-	-	-	-	-	-	Prof[N]		
-	120	-	120	-	-	-	-	-	-	-	-	Prof[kgf]		
0.100	0.100	-	0.100	0.100	0.100	-	-	-	-	-	-	P_i [kW]	CNH C-73 CNF C-78 CNV C-85	6070DA
45.0	45.0	-	45.0	45.0	45.0	-	-	-	-	-	-	T_{OUT} [N•m]		
4.59	4.59	-	4.59	4.59	4.59	-	-	-	-	-	-	T_{OUT} [kgf•m]		
1770	1770	-	1770	1770	1770	-	-	-	-	-	-	Prof[N]		
180	180	-	180	180	180	-	-	-	-	-	-	Prof[kgf]		
0.100	0.100	-	0.100	0.100	0.100	-	-	-	-	-	-	P_i [kW]	CNH C-73 CNF C-78 CNV C-85	6075DA
57.4	60.0	-	60.0	57.4	57.4	-	-	-	-	-	-	T_{OUT} [N•m]		
5.85	6.12	-	6.12	5.85	5.85	-	-	-	-	-	-	T_{OUT} [kgf•m]		
1580	1660	-	1660	1580	1580	-	-	-	-	-	-	Prof[N]		
161	169	-	169	161	161	-	-	-	-	-	-	Prof[kgf]		
0.100	0.100	0.100	0.100	0.100	0.100	0.100	0.100	0.100	0.100	-	-	P_i [kW]	CNH C-73 CNF C-78 CNV C-85	6090DA
146	150	150	150	146	146	150	146	150	150	-	-	T_{OUT} [N•m]		
14.9	15.3	15.3	15.3	14.9	14.9	15.3	14.9	15.3	15.3	-	-	T_{OUT} [kgf•m]		
3300	3310	3310	3310	3300	3300	3310	3300	3310	3310	-	-	Prof[N]		
336	338	338	338	336	336	338	336	338	338	-	-	Prof[kgf]		
-	0.100	0.100	0.100	-	-	0.100	-	0.100	0.100	-	-	P_i [kW]	CNH C-73 CNF C-78 CNV C-85	6095DA
-	200	193	200	-	-	192	-	192	192	-	-	T_{OUT} [N•m]		
-	20.4	19.6	20.4	-	-	19.6	-	19.6	19.6	-	-	T_{OUT} [kgf•m]		
-	3220	3240	3220	-	-	3240	-	3240	3240	-	-	Prof[N]		
-	328	330	328	-	-	330	-	330	330	-	-	Prof[kgf]		
0.100	0.100	0.100	0.100	0.100	0.100	0.100	0.100	0.100	0.100	-	-	P_i [kW]	CNH C-73 CNF C-78 CNV C-85	6100DA
250	250	250	250	250	250	250	250	250	250	-	-	T_{OUT} [N•m]		
25.5	25.5	25.5	25.5	25.5	25.5	25.5	25.5	25.5	25.5	-	-	T_{OUT} [kgf•m]		
5400	5400	5400	5400	5400	5400	5400	5400	5400	5400	-	-	Prof[N]		
550	550	550	550	550	550	550	550	550	550	-	-	Prof[kgf]		
0.100	0.100	0.100	0.100	0.100	0.100	0.100	0.100	0.100	0.100	-	-	P_i [kW]	CNH C-73 CNF C-78 CNV C-85	6105DA
296	300	300	300	296	296	300	296	300	300	-	-	T_{OUT} [N•m]		
30.2	30.6	30.6	30.6	30.2	30.2	30.6	30.2	30.6	30.6	-	-	T_{OUT} [kgf•m]		
5090	5400	4780	5400	5090	5090	4780	5090	4780	4780	-	-	Prof[N]		
519	550	488	550	519	519	488	519	488	488	-	-	Prof[kgf]		
0.100	0.100	0.100	0.100	0.100	0.100	0.100	0.100	0.100	0.100	-	-	P_i [kW]	CNH C-73 CNF C-78 CNV C-85	6120DA
525	525	525	525	525	525	525	525	525	525	-	-	T_{OUT} [N•m]		
53.5	53.5	53.5	53.5	53.5	53.5	53.5	53.5	53.5	53.5	-	-	T_{OUT} [kgf•m]		
9810	9810	9780	9810	9810	9810	9780	9810	9780	9780	-	-	Prof[N]		
1000	1000	997	1000	1000	1000	997	1000	997	997	-	-	Prof[kgf]		
-	-	-	-	-	-	-	-	-	-	0.100	0.100	P_i [kW]	CNH C-73 CNF C-78 CNV C-85	6120DB
-	-	-	-	-	-	-	-	-	-	525	525	T_{OUT} [N•m]		
-	-	-	-	-	-	-	-	-	-	53.5	53.5	T_{OUT} [kgf•m]		
-	-	-	-	-	-	-	-	-	-	9780	9780	Prof[N]		
-	-	-	-	-	-	-	-	-	-	997	997	Prof[kgf]		
0.106	0.100	0.100	0.100	0.100	0.100	0.100	0.100	0.100	0.100	-	-	P_i [kW]	CNH C-73 CNF C-78 CNV C-85	6125DA
630	630	630	630	630	630	630	630	630	630	-	-	T_{OUT} [N•m]		
64.2	64.2	64.2	64.2	64.2	64.2	64.2	64.2	64.2	64.2	-	-	T_{OUT} [kgf•m]		
9810	9810	9560	9810	9810	9810	9560	9810	9560	9560	-	-	Prof[N]		
1000	1000	974	1000	1000	1000	974	1000	974	974	-	-	Prof[kgf]		
-	-	-	-	-	-	-	-	-	-	0.100	0.100	P_i [kW]	CNH C-73 CNF C-78 CNV C-85	6125DB
-	-	-	-	-	-	-	-	-	-	630	630	T_{OUT} [N•m]		
-	-	-	-	-	-	-	-	-	-	64.2	64.2	T_{OUT} [kgf•m]		
-	-	-	-	-	-	-	-	-	-	9560	9560	Prof[N]		
-	-	-	-	-	-	-	-	-	-	974	974	Prof[kgf]		
0.200	0.200	0.200	0.200	0.200	0.200	0.200	0.200	0.200	0.200	-	-	P_i [kW]	CHH C-74 CHF C-79 CVV C-86	6130DA
912	780	848	780	912	912	848	912	848	848	-	-	T_{OUT} [N•m]		
93.0	79.5	86.5	79.5	93.0	93.0	86.5	93.0	86.5	86.5	-	-	T_{OUT} [kgf•m]		
14700	14700	14700	14700	14700	14700	14700	14700	14700	14700	-	-	Prof[N]		
1500	1500	1500	1500	1500	1500	1500	1500	1500	1500	-	-	Prof[kgf]		
1003	1247	1479	1849	2065	2537	3045	3481	4437	5133	6177	7569	Ratio[Z]	Dim. Page	Frame Size
1.45	1.16	0.980	0.784	0.702	0.572	0.476	0.417	0.327	0.282	0.235	0.192	n_2 [r/min]		

Note: 3. Necessary input power for starting is printed in bold face. Do not exceed allowable output torque after startup.

REDUCERS
Selection Tables
Ratio 104, 121 - 7569

Selection Tables 6000 Series Reducer

Double Reduction Ratio 104,121 ~ 7569 Frame Size: 6130DB ~ 6160DB

Input Speed	$n_1 = 1450$ r/min	n_1 : Input Speed [r/min]	T_{out} : Allowable output torque [N·m, kgf·m]
		n_2 : Output Speed [r/min]	Pro: Allowable output shaft radial load [N, kgf]
		P_1 : Allowable input power [kW]	*Consult us for Pro of CNF and CHF type.

Frame Size	n_2 [r/min] Ratio[Z]	13.9	12.0	10.1	8.79	7.44	6.28	5.31	4.55	3.85	3.07	2.59	2.23	1.98	1.72
		104	121	143	165	195	231	273	319	377	473	559	649	731	841
6130DB	P_1 [kW]	1.27	1.09	0.920	0.798	0.675	0.570	0.482	0.413	0.349	-	-	-	-	-
	T_{out} [N·m]	780	780	780	780	780	780	780	780	780	-	-	-	-	-
	T_{out} [kgf·m]	79.5	79.5	79.5	79.5	79.5	79.5	79.5	79.5	79.5	-	-	-	-	-
	Pro[N]	14700	14700	14700	14700	14700	14700	14700	14700	14700	-	-	-	-	-
	Pro[kgf]	1500	1500	1500	1500	1500	1500	1500	1500	1500	-	-	-	-	-
6130DC	P_1 [kW]	1.27	-	-	-	-	-	-	-	-	-	-	-	-	-
	T_{out} [N·m]	780	-	-	-	-	-	-	-	-	-	-	-	-	-
	T_{out} [kgf·m]	79.5	-	-	-	-	-	-	-	-	-	-	-	-	-
	Pro[N]	14700	-	-	-	-	-	-	-	-	-	-	-	-	-
	Pro[kgf]	1500	-	-	-	-	-	-	-	-	-	-	-	-	-
6135DA	P_1 [kW]	-	-	-	-	-	-	-	0.429	0.421	0.335	0.284	0.273	0.217	0.200
	T_{out} [N·m]	-	-	-	-	-	-	-	812	940	940	940	1050	940	940
	T_{out} [kgf·m]	-	-	-	-	-	-	-	82.8	95.8	95.8	95.8	107	95.8	95.8
	Pro[N]	-	-	-	-	-	-	-	14700	14700	14700	14700	14700	14700	14700
	Pro[kgf]	-	-	-	-	-	-	-	1500	1500	1500	1500	1500	1500	1500
6135DB	P_1 [kW]	1.52	1.31	1.11	0.961	0.813	0.686	0.581	0.497	0.421	0.335	-	-	-	-
	T_{out} [N·m]	940	940	940	940	940	940	940	940	940	940	-	-	-	-
	T_{out} [kgf·m]	95.8	95.8	95.8	95.8	95.8	95.8	95.8	95.8	95.8	95.8	-	-	-	-
	Pro[N]	14700	14700	14700	14700	14700	14700	14700	14700	14700	14700	-	-	-	-
	Pro[kgf]	1500	1500	1500	1500	1500	1500	1500	1500	1500	1500	-	-	-	-
6135DC	P_1 [kW]	1.52	1.31	-	-	-	-	-	-	-	-	-	-	-	-
	T_{out} [N·m]	940	940	-	-	-	-	-	-	-	-	-	-	-	-
	T_{out} [kgf·m]	95.8	95.8	-	-	-	-	-	-	-	-	-	-	-	-
	Pro[N]	14700	14700	-	-	-	-	-	-	-	-	-	-	-	-
	Pro[kgf]	1500	1500	-	-	-	-	-	-	-	-	-	-	-	-
6140DA	P_1 [kW]	-	-	-	-	-	-	-	-	0.429	0.429	0.370	0.318	0.283	0.246
	T_{out} [N·m]	-	-	-	-	-	-	-	-	960	1200	1230	1230	1230	1230
	T_{out} [kgf·m]	-	-	-	-	-	-	-	-	97.8	123	125	125	125	125
	Pro[N]	-	-	-	-	-	-	-	-	16000	16000	16000	16000	16000	16000
	Pro[kgf]	-	-	-	-	-	-	-	-	1630	1630	1630	1630	1630	1630
6140DB	P_1 [kW]	1.60	1.60	1.45	1.25	1.06	0.895	0.757	0.648	0.548	0.437	0.370	-	-	-
	T_{out} [N·m]	986	1150	1230	1230	1230	1230	1230	1230	1230	1230	1230	-	-	-
	T_{out} [kgf·m]	100	117	125	125	125	125	125	125	125	125	125	-	-	-
	Pro[N]	16000	16000	16000	16000	16000	16000	16000	16000	16000	16000	16000	-	-	-
	Pro[kgf]	1630	1630	1630	1630	1630	1630	1630	1630	1630	1630	1630	-	-	-
69140DC	P_1 [kW]	1.99	1.71	1.45	1.25	-	-	-	-	-	-	-	-	-	-
	T_{out} [N·m]	1230	1230	1230	1230	-	-	-	-	-	-	-	-	-	-
	T_{out} [kgf·m]	125	125	125	125	-	-	-	-	-	-	-	-	-	-
	Pro[N]	16000	16000	16000	16000	-	-	-	-	-	-	-	-	-	-
	Pro[kgf]	1630	1630	1630	1630	-	-	-	-	-	-	-	-	-	-
6145DA	P_1 [kW]	-	-	-	-	-	-	-	-	-	-	0.413	0.356	0.316	0.275
	T_{out} [N·m]	-	-	-	-	-	-	-	-	-	-	1370	1370	1370	1370
	T_{out} [kgf·m]	-	-	-	-	-	-	-	-	-	-	140	140	140	140
	Pro[N]	-	-	-	-	-	-	-	-	-	-	15700	16000	15700	15800
	Pro[kgf]	-	-	-	-	-	-	-	-	-	-	1600	1630	1600	1610
6145DB	P_1 [kW]	-	-	1.60	1.39	1.17	0.977	0.827	0.725	0.613	0.489	0.413	0.356	-	0.275
	T_{out} [N·m]	-	-	1360	1360	1360	1340	1340	1370	1370	1370	1370	1370	-	1370
	T_{out} [kgf·m]	-	-	138	138	138	136	136	140	140	140	140	140	-	140
	Pro[N]	-	-	16000	16000	16000	16000	16000	16000	15800	15800	15700	15700	-	15800
	Pro[kgf]	-	-	1630	1630	1630	1630	1630	1610	1610	1600	1600	1630	-	1610
6145DC	P_1 [kW]	2.22	1.80	1.62	1.39	-	-	-	-	-	-	-	-	-	-
	T_{out} [N·m]	1370	1290	1370	1360	-	-	-	-	-	-	-	-	-	-
	T_{out} [kgf·m]	140	132	140	138	-	-	-	-	-	-	-	-	-	-
	Pro[N]	15900	16000	15900	16000	-	-	-	-	-	-	-	-	-	-
	Pro[kgf]	1620	1630	1620	1630	-	-	-	-	-	-	-	-	-	-
6160DA	P_1 [kW]	-	-	-	1.60	1.52	1.28	1.08	0.928	0.785	0.619	0.524	0.456	0.400	0.400
	T_{out} [N·m]	-	-	-	1560	1760	1760	1760	1760	1760	1740	1740	1760	1740	1760
	T_{out} [kgf·m]	-	-	-	159	179	179	179	179	179	177	177	179	177	179
	Pro[N]	-	-	-	22100	22100	22100	22100	22100	22100	22100	22100	22100	22100	22100
	Pro[kgf]	-	-	-	2250	2250	2250	2250	2250	2250	2250	2250	2250	2250	2250
6160DB	P_1 [kW]	2.85	2.45	2.07	1.79	1.52	1.28	-	-	-	-	-	-	-	-
	T_{out} [N·m]	1760	1760	1760	1760	1760	1760	-	-	-	-	-	-	-	-
	T_{out} [kgf·m]	179	179	179	179	179	179	-	-	-	-	-	-	-	-
	Pro[N]	22100	22100	22100	22100	22100	22100	-	-	-	-	-	-	-	-
	Pro[kgf]	2250	2250	2250	2250	2250	2250	-	-	-	-	-	-	-	-
Frame Size	Ratio[Z]	104	121	143	165	195	231	273	319	377	473	559	649	731	841
	n_2 [r/min]	13.9	12.0	10.1	8.79	7.44	6.28	5.31	4.55	3.85	3.07	2.59	2.23	1.98	1.72

Note: 1. Allowable radial load Pro is the value at the midpoint of the output shaft. Refer to pages F-11~12 when radial load is off the midpoint of output shaft and for checking thrust load.

2. Refer to pages F-15~16 for allowable radial load for input shaft.

Selection Tables 6000 Series Reducer

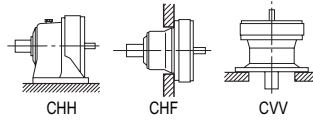

Input Speed $n_1 = 1450$ r/min

1.45	1.16	0.980	0.784	0.702	0.572	0.476	0.417	0.327	0.282	0.235	0.192	n_2 [r/min]	Dim. Page	Frame Size	
1003	1247	1479	1849	2065	2537	3045	3481	4437	5133	6177	7569	Ratio[Z]			
-	-	-	-	-	-	-	-	-	-	0.200	0.200	P_i [kW] T_{OUT} [N•m] T_{OUT} [kgf•m] Prof[N] Prof[kgf]	CHH C-74 CHF C-79 CW C-86	6130DB	
-	-	-	-	-	-	-	-	-	-	848	848				
-	-	-	-	-	-	-	-	-	-	86.5	86.5				
-	-	-	-	-	-	-	-	-	-	14700	14700				
-	-	-	-	-	-	-	-	-	-	-	1500	1500			
-	-	-	-	-	-	-	-	-	-	-	-	P_i [kW] T_{OUT} [N•m] T_{OUT} [kgf•m] Prof[N] Prof[kgf]	CHH C-74 CHF C-79 CW C-86	6130DC	
-	-	-	-	-	-	-	-	-	-	-	-				
-	-	-	-	-	-	-	-	-	-	-	-				
-	-	-	-	-	-	-	-	-	-	-	-				
0.200	0.200	0.200	0.200	0.200	0.200	0.200	0.200	0.200	0.200	-	-	P_i [kW] T_{OUT} [N•m] T_{OUT} [kgf•m] Prof[N] Prof[kgf]	CHH C-74 CHF C-79 CW C-86	6135DA	
1050	940	979	940	1050	1050	979	1050	979	979	-	-				
107	95.8	99.8	95.8	107	107	99.8	107	99.8	99.8	-	-				
14700	14700	14700	14700	14700	14700	14700	14700	14700	14700	-	-				
-	-	-	-	-	-	-	-	-	-	-	1500	-			
-	-	-	-	-	-	-	-	-	-	-	-	P_i [kW] T_{OUT} [N•m] T_{OUT} [kgf•m] Prof[N] Prof[kgf]	CHH C-74 CHF C-79 CW C-86	6135DB	
-	-	-	-	-	-	-	-	-	-	979	979				
-	-	-	-	-	-	-	-	-	-	99.8	99.8				
-	-	-	-	-	-	-	-	-	-	14700	14700				
-	-	-	-	-	-	-	-	-	-	-	1500	1500			
-	-	-	-	-	-	-	-	-	-	-	-	P_i [kW] T_{OUT} [N•m] T_{OUT} [kgf•m] Prof[N] Prof[kgf]	CHH C-74 CHF C-79 CW C-86	6135DC	
-	-	-	-	-	-	-	-	-	-	-	-				
-	-	-	-	-	-	-	-	-	-	-	-				
-	-	-	-	-	-	-	-	-	-	-	-				
0.206	0.200	0.200	0.200	0.200	0.200	0.200	0.200	0.200	0.200	-	-	P_i [kW] T_{OUT} [N•m] T_{OUT} [kgf•m] Prof[N] Prof[kgf]	CHH C-74 CHF C-79 CW C-86	6140DA	
1230	1230	1230	1230	1230	1230	1230	1230	1230	1230	-	-				
125	125	125	125	125	125	125	125	125	125	-	-				
16000	16000	16000	16000	16000	16000	16000	16000	16000	16000	-	-				
1630	1630	1630	1630	1630	1630	1630	1630	1630	1630	-	-				
-	-	-	-	-	-	-	-	-	-	-	0.200	0.200	P_i [kW] T_{OUT} [N•m] T_{OUT} [kgf•m] Prof[N] Prof[kgf]	CHH C-74 CHF C-79 CW C-86	6140DB
-	-	-	-	-	-	-	-	-	-	1230	1230				
-	-	-	-	-	-	-	-	-	-	125	125				
-	-	-	-	-	-	-	-	-	-	16000	16000				
-	-	-	-	-	-	-	-	-	-	-	1630	1630			
-	-	-	-	-	-	-	-	-	-	-	-	P_i [kW] T_{OUT} [N•m] T_{OUT} [kgf•m] Prof[N] Prof[kgf]	CHH C-74 CHF C-79 CW C-86	69140DC	
-	-	-	-	-	-	-	-	-	-	-	-				
-	-	-	-	-	-	-	-	-	-	-	-				
-	-	-	-	-	-	-	-	-	-	-	-				
0.230	0.200	0.200	0.200	0.200	0.200	0.200	0.200	0.200	0.200	-	-	P_i [kW] T_{OUT} [N•m] T_{OUT} [kgf•m] Prof[N] Prof[kgf]	CHH C-74 CHF C-79 CW C-86	6145DA	
1370	1370	1250	1370	1370	1370	1250	1370	1250	1250	-	-				
140	140	127	140	140	140	127	140	127	127	-	-				
16000	15700	16000	15700	16000	16000	16000	16000	16000	16000	-	-				
1630	1600	1630	1600	1630	1630	1630	1630	1630	1630	-	-				
-	-	-	-	-	-	-	-	-	-	-	0.200	0.200	P_i [kW] T_{OUT} [N•m] T_{OUT} [kgf•m] Prof[N] Prof[kgf]	CHH C-74 CHF C-79 CW C-86	6145DB
-	-	-	-	-	-	-	-	-	-	1250	1250				
-	-	-	-	-	-	-	-	-	-	127	127				
-	-	-	-	-	-	-	-	-	-	16000	16000				
-	-	-	-	-	-	-	-	-	-	-	1630	1630			
-	-	-	-	-	-	-	-	-	-	-	-	P_i [kW] T_{OUT} [N•m] T_{OUT} [kgf•m] Prof[N] Prof[kgf]	CHH C-74 CHF C-79 CW C-86	6145DC	
-	-	-	-	-	-	-	-	-	-	-	-				
-	-	-	-	-	-	-	-	-	-	-	-				
-	-	-	-	-	-	-	-	-	-	-	-				
0.400	0.400	0.200	0.200	0.200	0.200	0.200	0.200	0.200	0.200	0.200	0.200	P_i [kW] T_{OUT} [N•m] T_{OUT} [kgf•m] Prof[N] Prof[kgf]	CHH C-74 CHF C-79 CW C-86	6160DA	
1760	1740	1760	1740	1760	1760	1760	1760	1760	1760	1760	1760				
179	177	179	177	179	179	179	179	179	179	179	179				
22100	22100	22100	22100	22100	22100	22100	22100	22100	22100	22100	22100				
2250	2250	2250	2250	2250	2250	2250	2250	2250	2250	2250	2250				
-	-	-	-	-	-	-	-	-	-	-	-	P_i [kW] T_{OUT} [N•m] T_{OUT} [kgf•m] Prof[N] Prof[kgf]	CHH C-74 CHF C-79 CW C-86	6160DB	
-	-	-	-	-	-	-	-	-	-	-	-				
-	-	-	-	-	-	-	-	-	-	-	-				
-	-	-	-	-	-	-	-	-	-	-	-				
1003	1247	1479	1849	2065	2537	3045	3481	4437	5133	6177	7569	Ratio[Z]	Dim. Page	Frame Size	
1.45	1.16	0.980	0.784	0.702	0.572	0.476	0.417	0.327	0.282	0.235	0.192	n_2 [r/min]			

Note: 3. Necessary input power for starting is printed in bold face. Do not exceed allowable output torque after startup.

REDUCERS
Selection Tables
Ratio 104, 121 - 7569

Selection Tables 6000 Series Reducer

Double Reduction Ratio 104,121 ~ 7569 Frame Size: 6160DC ~ 6185DA

Input Speed	$n_1 = 1450$ r/min	n_1 : Input Speed [r/min]	T_{out} : Allowable output torque [N·m, kgf·m]
		n_2 : Output Speed [r/min]	Pro: Allowable output shaft radial load [N, kgf]
		P_1 : Allowable input power [kW]	*Consult us for Pro of CNF and CHF type.

Frame Size	n_2 [r/min]	13.9	12.0	10.1	8.79	7.44	6.28	5.31	4.55	3.85	3.07	2.59	2.23	1.98	1.72
	Ratio[Z]	104	121	143	165	195	231	273	319	377	473	559	649	731	841
6160DC	P_1 [kW]	2.85	2.45	2.07	-	-	-	-	-	-	-	-	-	-	-
	T_{out} [N·m]	1760	1760	1760	-	-	-	-	-	-	-	-	-	-	-
	T_{out} [kgf·m]	179	179	179	-	-	-	-	-	-	-	-	-	-	-
	Pro[N]	22100	22100	22100	-	-	-	-	-	-	-	-	-	-	-
	Pro[kgf]	2250	2250	2250	-	-	-	-	-	-	-	-	-	-	-
6165DA	P_1 [kW]	-	-	-	-	1.60	1.53	1.30	1.11	0.940	0.749	0.634	0.546	0.485	0.421
	T_{out} [N·m]	-	-	-	-	1850	2100	2100	2100	2100	2100	2100	2100	2100	2100
	T_{out} [kgf·m]	-	-	-	-	188	214	214	214	214	214	214	214	214	214
	Pro[N]	-	-	-	-	22100	22100	22100	22100	22100	22100	22100	22100	22100	22100
	Pro[kgf]	-	-	-	-	2250	2250	2250	2250	2250	2250	2250	2250	2250	2250
6165DB	P_1 [kW]	3.36	2.93	2.48	2.15	1.82	1.53	1.30	-	-	-	-	-	-	-
	T_{out} [N·m]	2070	2100	2100	2100	2100	2100	2100	-	-	-	-	-	-	-
	T_{out} [kgf·m]	211	214	214	214	214	214	214	-	-	-	-	-	-	-
	Pro[N]	22100	22100	22100	22100	22100	22100	22100	-	-	-	-	-	-	-
	Pro[kgf]	2250	2250	2250	2250	2250	2250	2250	-	-	-	-	-	-	-
6165DC	P_1 [kW]	3.41	2.93	2.48	2.15	-	-	-	-	-	-	-	-	-	-
	T_{out} [N·m]	2100	2100	2100	2100	-	-	-	-	-	-	-	-	-	-
	T_{out} [kgf·m]	214	214	214	214	-	-	-	-	-	-	-	-	-	-
	Pro[N]	22100	22100	22100	22100	-	-	-	-	-	-	-	-	-	-
	Pro[kgf]	2250	2250	2250	2250	-	-	-	-	-	-	-	-	-	-
6170DA	P_1 [kW]	-	-	-	-	-	1.60	1.56	1.34	1.13	0.902	0.764	0.658	0.584	0.508
	T_{out} [N·m]	-	-	-	-	-	2190	2530	2530	2530	2530	2530	2530	2530	2530
	T_{out} [kgf·m]	-	-	-	-	-	223	258	258	258	258	258	258	258	258
	Pro[N]	-	-	-	-	-	29500	29500	29500	29500	29500	29500	29500	29500	29500
	Pro[kgf]	-	-	-	-	-	3010	3010	3010	3010	3010	3010	3010	3010	3010
6170DB	P_1 [kW]	-	3.36	2.98	2.59	2.19	1.85	1.56	1.34	-	-	-	-	-	-
	T_{out} [N·m]	-	2410	2530	2530	2530	2530	2530	2530	-	-	-	-	-	-
	T_{out} [kgf·m]	-	245	258	258	258	258	258	258	-	-	-	-	-	-
	Pro[N]	-	29500	29500	29500	29500	29500	29500	29500	-	-	-	-	-	-
	Pro[kgf]	-	3010	3010	3010	3010	3010	3010	3010	-	-	-	-	-	-
6170DC	P_1 [kW]	4.10	3.53	2.98	2.59	2.19	1.85	-	-	-	-	-	-	-	-
	T_{out} [N·m]	2530	2530	2530	2530	2530	2530	-	-	-	-	-	-	-	-
	T_{out} [kgf·m]	258	258	258	258	258	258	-	-	-	-	-	-	-	-
	Pro[N]	29500	29500	29500	29500	29500	29500	-	-	-	-	-	-	-	-
	Pro[kgf]	3010	3010	3010	3010	3010	3010	-	-	-	-	-	-	-	-
6175DA	P_1 [kW]	-	-	-	-	-	-	1.60	1.60	1.41	1.12	0.951	0.819	0.727	0.632
	T_{out} [N·m]	-	-	-	-	-	-	2590	3020	3150	3150	3150	3150	3150	3150
	T_{out} [kgf·m]	-	-	-	-	-	-	264	308	321	321	321	321	321	321
	Pro[N]	-	-	-	-	-	-	29500	29500	29500	29500	29500	29500	29500	29500
	Pro[kgf]	-	-	-	-	-	-	3010	3010	3010	3010	3010	3010	3010	3010
6175DB	P_1 [kW]	-	-	3.36	3.22	2.73	2.30	1.95	1.67	1.41	-	-	-	-	-
	T_{out} [N·m]	-	-	2840	3150	3150	3150	3150	3150	3150	-	-	-	-	-
	T_{out} [kgf·m]	-	-	290	321	321	321	321	321	321	-	-	-	-	-
	Pro[N]	-	-	29500	29500	29500	29500	29500	29500	29500	-	-	-	-	-
	Pro[kgf]	-	-	3010	3010	3010	3010	3010	3010	3010	-	-	-	-	-
6175DC	P_1 [kW]	5.11	4.39	3.72	3.22	2.73	2.30	1.95	-	-	-	-	-	-	-
	T_{out} [N·m]	3150	3150	3150	3150	3150	3150	3150	-	-	-	-	-	-	-
	T_{out} [kgf·m]	321	321	321	321	321	321	321	-	-	-	-	-	-	-
	Pro[N]	29500	29500	29500	29500	29500	29500	29500	-	-	-	-	-	-	-
	Pro[kgf]	3010	3010	3010	3010	3010	3010	3010	-	-	-	-	-	-	-
6180DA	P_1 [kW]	-	-	-	3.36	3.36	2.96	2.50	2.14	1.81	1.45	1.22	1.05	0.937	0.813
	T_{out} [N·m]	-	-	-	3280	3880	4050	4050	4050	4050	4060	4060	4050	4060	4050
	T_{out} [kgf·m]	-	-	-	335	395	413	413	413	413	414	414	413	414	413
	Pro[N]	-	-	-	41700	41700	41700	41700	41700	41700	41700	41700	41700	41700	41700
	Pro[kgf]	-	-	-	4250	4250	4250	4250	4250	4250	4250	4250	4250	4250	4250
6180DB	P_1 [kW]	6.59	5.66	4.79	4.15	3.51	2.96	2.50	2.14	-	-	-	-	-	-
	T_{out} [N·m]	4060	4060	4060	4060	4060	4050	4050	4050	-	-	-	-	-	-
	T_{out} [kgf·m]	414	414	414	414	414	413	413	413	-	-	-	-	-	-
	Pro[N]	40200	41700	41700	41700	41700	41700	41700	41700	-	-	-	-	-	-
	Pro[kgf]	4100	4250	4250	4250	4250	4250	4250	4250	-	-	-	-	-	-
6185DA	P_1 [kW]	-	-	-	-	-	-	3.36	3.09	2.64	2.24	1.78	1.51	1.30	1.15
	T_{out} [N·m]	-	-	-	-	-	-	4600	5000	5000	5000	5000	5000	5000	5000
	T_{out} [kgf·m]	-	-	-	-	-	-	468	510	510	510	510	510	510	510
	Pro[N]	-	-	-	-	-	-	41700	41700	41700	41700	41700	41700	41600	41700
	Pro[kgf]	-	-	-	-	-	-	4250	4250	4250	4250	4250	4240	4250	4250
Frame Size	Ratio[Z]	104	121	143	165	195	231	273	319	377	473	559	649	731	841
	n_2 [r/min]	13.9	12.0	10.1	8.79	7.44	6.28	5.31	4.55	3.85	3.07	2.59	2.23	1.98	1.72

Note: 1. Allowable radial load Pro is the value at the midpoint of the output shaft. Refer to pages F-11~12 when radial load is off the midpoint of output shaft and for checking thrust load.

2. Refer to pages F-15~16 for allowable radial load for input shaft.

Selection Tables 6000 Series Reducer

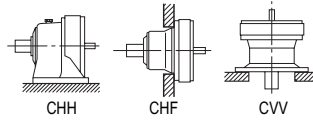

Input Speed	$n_1 = 1450$ r/min
-------------	--------------------

1.45	1.16	0.980	0.784	0.702	0.572	0.476	0.417	0.327	0.282	0.235	0.192	n_2 [r/min]	Dim. Page	Frame Size
1003	1247	1479	1849	2065	2537	3045	3481	4437	5133	6177	7569	Ratio[Z]		
-	-	-	-	-	-	-	-	-	-	-	-	P_i [kW]	CHH C-75 CHF C-80 CVW C-87	6160DC
-	-	-	-	-	-	-	-	-	-	-	-	T_{OUT} [N·m]		
-	-	-	-	-	-	-	-	-	-	-	-	T_{OUT} [kgf·m]		
-	-	-	-	-	-	-	-	-	-	-	-	Prof [N]		
0.400	0.400	0.400	0.200	0.200	0.200	0.200	0.200	0.200	0.200	0.200	0.200	P_i [kW]	CHH C-74 CHF C-79 CVW C-86	6165DA
2100	2100	2050	2100	2100	2100	2050	2100	2050	2050	2050	2050	T_{OUT} [N·m]		
214	214	209	214	214	214	209	214	209	209	209	209	T_{OUT} [kgf·m]		
22100	22100	21800	22100	22100	22100	21800	22100	21800	21800	21800	21800	Prof [N]		
2250	2250	2220	2250	2250	2250	2220	2250	2220	2220	2220	2220	Prof [kgf]		
-	-	-	-	-	-	-	-	-	-	-	-	P_i [kW]	CHH C-74 CHF C-79 CVW C-86	6165DB
-	-	-	-	-	-	-	-	-	-	-	-	T_{OUT} [N·m]		
-	-	-	-	-	-	-	-	-	-	-	-	T_{OUT} [kgf·m]		
-	-	-	-	-	-	-	-	-	-	-	-	Prof [N]		
-	-	-	-	-	-	-	-	-	-	-	-	Prof [kgf]		
-	-	-	-	-	-	-	-	-	-	-	-	P_i [kW]	CHH C-75 CHF C-80 CVW C-87	6165DC
-	-	-	-	-	-	-	-	-	-	-	-	T_{OUT} [N·m]		
-	-	-	-	-	-	-	-	-	-	-	-	T_{OUT} [kgf·m]		
-	-	-	-	-	-	-	-	-	-	-	-	Prof [N]		
-	-	-	-	-	-	-	-	-	-	-	-	Prof [kgf]		
0.426	0.400	0.400	0.400	0.207	0.200	0.200	0.200	0.200	0.200	0.200	0.200	P_i [kW]	CHH C-74 CHF C-79 CVW C-86	6170DA
2530	2530	2530	2530	2530	2530	2530	2530	2530	2530	2530	2530	T_{OUT} [N·m]		
258	258	258	258	258	258	258	258	258	258	258	258	T_{OUT} [kgf·m]		
29500	29500	29500	29500	29500	29500	29500	29500	29500	29500	29500	29500	Prof [N]		
3010	3010	3010	3010	3010	3010	3010	3010	3010	3010	3010	3010	Prof [kgf]		
-	-	-	-	-	-	-	-	-	-	-	-	P_i [kW]	CHH C-74 CHF C-79 CVW C-86	6170DB
-	-	-	-	-	-	-	-	-	-	-	-	T_{OUT} [N·m]		
-	-	-	-	-	-	-	-	-	-	-	-	T_{OUT} [kgf·m]		
-	-	-	-	-	-	-	-	-	-	-	-	Prof [N]		
-	-	-	-	-	-	-	-	-	-	-	-	Prof [kgf]		
-	-	-	-	-	-	-	-	-	-	-	-	P_i [kW]	CHH C-75 CHF C-80 CVW C-87	6170DC
-	-	-	-	-	-	-	-	-	-	-	-	T_{OUT} [N·m]		
-	-	-	-	-	-	-	-	-	-	-	-	T_{OUT} [kgf·m]		
-	-	-	-	-	-	-	-	-	-	-	-	Prof [N]		
-	-	-	-	-	-	-	-	-	-	-	-	Prof [kgf]		
0.530	0.426	0.400	0.400	0.400	0.209	0.200	0.200	0.200	0.200	0.200	0.200	P_i [kW]	CHH C-74 CHF C-79 CVW C-86	6175DA
3150	3150	3150	3150	3150	3150	3150	3150	3150	3150	3150	3150	T_{OUT} [N·m]		
321	321	321	321	321	321	321	321	321	321	321	321	T_{OUT} [kgf·m]		
29500	29500	29500	29500	29500	29500	29500	29500	29500	29500	29500	29500	Prof [N]		
3010	3010	3010	3010	3010	3010	3010	3010	3010	3010	3010	3010	Prof [kgf]		
-	-	-	-	-	-	-	-	-	-	-	-	P_i [kW]	CHH C-74 CHF C-79 CVW C-86	6175DB
-	-	-	-	-	-	-	-	-	-	-	-	T_{OUT} [N·m]		
-	-	-	-	-	-	-	-	-	-	-	-	T_{OUT} [kgf·m]		
-	-	-	-	-	-	-	-	-	-	-	-	Prof [N]		
-	-	-	-	-	-	-	-	-	-	-	-	Prof [kgf]		
-	-	-	-	-	-	-	-	-	-	-	-	P_i [kW]	CHH C-75 CHF C-80 CVW C-87	6175DC
-	-	-	-	-	-	-	-	-	-	-	-	T_{OUT} [N·m]		
-	-	-	-	-	-	-	-	-	-	-	-	T_{OUT} [kgf·m]		
-	-	-	-	-	-	-	-	-	-	-	-	Prof [N]		
-	-	-	-	-	-	-	-	-	-	-	-	Prof [kgf]		
0.750	0.750	0.463	0.400	0.400	0.400	0.400	0.400	0.400	0.400	0.400	0.400	P_i [kW]	CHH C-74 CHF C-79 CVW C-86	6180DA
4050	4060	4060	4060	4050	4050	4060	4050	4060	4060	4060	4060	T_{OUT} [N·m]		
413	414	414	414	413	413	414	413	414	414	414	414	T_{OUT} [kgf·m]		
41700	41700	41700	41700	41700	41700	41700	41700	41700	41700	41700	41700	Prof [N]		
4250	4250	4250	4250	4250	4250	4250	4250	4250	4250	4250	4250	Prof [kgf]		
-	-	-	-	-	-	-	-	-	-	-	-	P_i [kW]	CHH C-75 CHF C-80 CVW C-87	6180DB
-	-	-	-	-	-	-	-	-	-	-	-	T_{OUT} [N·m]		
-	-	-	-	-	-	-	-	-	-	-	-	T_{OUT} [kgf·m]		
-	-	-	-	-	-	-	-	-	-	-	-	Prof [N]		
-	-	-	-	-	-	-	-	-	-	-	-	Prof [kgf]		
0.841	0.750	0.750	0.750	0.408	0.400	0.400	0.400	0.400	0.400	0.400	0.400	P_i [kW]	CHH C-74 CHF C-79 CVW C-86	6185DA
5000	5000	5000	5000	5000	5000	5000	5000	5000	5000	5000	5000	T_{OUT} [N·m]		
510	510	510	510	510	510	510	510	510	510	510	510	T_{OUT} [kgf·m]		
41600	41700	41700	41700	41600	41600	41700	41600	41700	41700	41700	41700	Prof [N]		
4240	4250	4250	4250	4240	4240	4250	4240	4250	4250	4250	4250	Prof [kgf]		
1003	1247	1479	1849	2065	2537	3045	3481	4437	5133	6177	7569	Ratio[Z]	Dim. Page	Frame Size
1.45	1.16	0.980	0.784	0.702	0.572	0.476	0.417	0.327	0.282	0.235	0.192	n_2 [r/min]		

Note: 3. Necessary input power for starting is printed in bold face. Do not exceed allowable output torque after startup.

Selection Tables
 Ratio 104, 121 - 7569
 REDUCERS

Selection Tables 6000 Series Reducer

Double Reduction Ratio 104,121 ~ 7569 Frame Size: 6185DB ~ 6235DB

Input Speed	$n_1 = 1450$ r/min	n_1 : Input Speed [r/min]	T_{out} : Allowable output torque [N·m, kgf·m]
		n_2 : Output Speed [r/min]	Pro: Allowable output shaft radial load [N, kgf]
		P_i : Allowable input power [kW]	*Consult us for Pro of CNF and CHF type.

Frame Size	n_2 [r/min]	13.9	12.0	10.1	8.79	7.44	6.28	5.31	4.55	3.85	3.07	2.59	2.23	1.98	1.72
	Ratio[Z]	104	121	143	165	195	231	273	319	377	473	559	649	731	841
6185DB	P_i [kW]	7.95	6.70	5.78	5.03	4.26	3.65	3.09	2.64	2.24	-	-	-	-	-
	T_{out} [N·m]	4900	4810	4900	4920	4920	5000	5000	5000	5000	-	-	-	-	-
	T_{out} [kgf·m]	500	490	500	502	502	510	510	510	510	-	-	-	-	-
	Pro[N]	39900	41700	41700	41700	41700	41700	41700	41700	41700	-	-	-	-	-
	Pro[kgf]	4060	4250	4250	4250	4250	4250	4250	4250	4250	-	-	-	-	-
6190DA	P_i [kW]	-	-	6.25	6.25	5.52	4.66	3.94	3.37	2.85	2.28	1.93	1.66	1.47	1.28
	T_{out} [N·m]	-	-	5300	6110	6380	6380	6380	6380	6380	6380	6380	6380	6380	6380
	T_{out} [kgf·m]	-	-	540	623	650	650	650	650	650	650	650	650	650	650
	Pro[N]	-	-	59000	59000	58900	59000	59000	59000	59000	59000	59000	59000	58600	59000
	Pro[kgf]	-	-	6010	6010	6000	6010	6010	6010	6010	6010	6010	5970	6010	
6190DB	P_i [kW]	10.3	8.90	7.53	6.52	5.52	4.66	-	-	-	-	-	-	-	-
	T_{out} [N·m]	6380	6380	6380	6380	6380	6380	-	-	-	-	-	-	-	-
	T_{out} [kgf·m]	650	650	650	650	650	650	-	-	-	-	-	-	-	-
	Pro[N]	55800	59000	58700	58900	58900	59000	-	-	-	-	-	-	-	-
	Pro[kgf]	5690	6010	5980	6000	6000	6010	-	-	-	-	-	-	-	-
6195DA	P_i [kW]	-	-	-	-	5.63	5.81	4.92	4.21	3.56	2.84	2.40	2.07	1.84	1.60
	T_{out} [N·m]	-	-	-	-	6500	7960	7960	7960	7960	7960	7960	7960	7960	7960
	T_{out} [kgf·m]	-	-	-	-	663	811	811	811	811	811	811	811	811	811
	Pro[N]	-	-	-	-	58800	59000	59000	59000	59000	59000	59000	59000	58100	59000
	Pro[kgf]	-	-	-	-	6000	6010	6010	6010	6010	6010	6010	5930	6010	
6195DB	P_i [kW]	11.9	10.6	9.00	8.09	6.84	5.81	4.92	-	-	-	-	-	-	-
	T_{out} [N·m]	7350	7580	7630	7910	7910	7960	7960	-	-	-	-	-	-	-
	T_{out} [kgf·m]	750	773	778	806	806	811	811	-	-	-	-	-	-	-
	Pro[N]	55400	59000	58200	58300	58300	59000	59000	-	-	-	-	-	-	-
	Pro[kgf]	5650	6010	5940	5940	5940	6010	6010	-	-	-	-	-	-	-
6205DA	P_i [kW]	-	-	-	-	-	-	5.17	4.27	3.83	2.95	2.64	2.20	2.20	2.20
	T_{out} [N·m]	-	-	-	-	-	-	8370	8080	8550	8280	8760	8300	9300	9230
	T_{out} [kgf·m]	-	-	-	-	-	-	853	823	872	844	893	846	948	941
	Pro[N]	-	-	-	-	-	-	84100	84100	84100	84100	84100	84100	84100	84100
	Pro[kgf]	-	-	-	-	-	-	8570	8570	8570	8570	8570	8570	8570	8570
6205DB	P_i [kW]	-	11.9	-	9.48	8.02	6.77	5.73	4.88	4.13	3.32	2.81	2.42	2.20	-
	T_{out} [N·m]	-	8560	-	9270	9270	9270	9270	9230	9230	9300	9300	9300	9300	-
	T_{out} [kgf·m]	-	872	-	945	945	945	945	941	941	948	948	948	948	-
	Pro[N]	-	84100	-	84100	84100	84100	84100	84100	84100	84100	84100	84100	84100	-
	Pro[kgf]	-	8570	-	8570	8570	8570	8570	8570	8570	8570	8570	8570	8570	-
6215DA	P_i [kW]	-	-	-	11.9	10.5	9.13	7.72	6.69	5.66	4.51	3.82	3.29	2.92	2.54
	T_{out} [N·m]	-	-	-	11700	12200	12500	12500	12700	12700	12700	12700	12700	12700	12700
	T_{out} [kgf·m]	-	-	-	1190	1240	1270	1270	1290	1290	1290	1290	1290	1290	1290
	Pro[N]	-	-	-	104000	104000	104000	104000	104000	104000	104000	104000	104000	104000	104000
	Pro[kgf]	-	-	-	10600	10600	10600	10600	10600	10600	10600	10600	10600	10600	10600
6215DB	P_i [kW]	-	15.9	-	12.4	10.5	-	-	-	-	-	-	-	-	-
	T_{out} [N·m]	-	11400	-	12200	12200	-	-	-	-	-	-	-	-	-
	T_{out} [kgf·m]	-	1160	-	1240	1240	-	-	-	-	-	-	-	-	-
	Pro[N]	-	104000	-	104000	104000	-	-	-	-	-	-	-	-	-
	Pro[kgf]	-	10600	-	10600	10600	-	-	-	-	-	-	-	-	-
6225DA	P_i [kW]	-	-	-	-	10.8	10.8	9.15	7.95	6.73	5.71	4.83	4.13	3.69	3.02
	T_{out} [N·m]	-	-	-	-	12500	14800	14800	15000	15000	16000	16000	15900	16000	15000
	T_{out} [kgf·m]	-	-	-	-	1270	1510	1510	1530	1530	1630	1630	1620	1630	1530
	Pro[N]	-	-	-	-	129000	137000	145000	145000	145000	145000	145000	145000	145000	145000
	Pro[kgf]	-	-	-	-	13200	14000	14700	14800	14800	14800	14800	14800	14800	14800
6225DB	P_i [kW]	-	18.8	-	14.8	12.5	10.8	-	-	-	-	-	-	-	-
	T_{out} [N·m]	-	13500	-	14500	14500	14800	-	-	-	-	-	-	-	-
	T_{out} [kgf·m]	-	1370	-	1480	1480	1510	-	-	-	-	-	-	-	-
	Pro[N]	-	113000	-	122000	129000	137000	-	-	-	-	-	-	-	-
	Pro[kgf]	-	11500	-	12500	13100	14000	-	-	-	-	-	-	-	-
6235DA	P_i [kW]	-	25.4	-	20.0	17.0	13.8	11.7	10.00	8.46	7.31	6.19	5.33	4.73	3.79
	T_{out} [N·m]	-	18200	-	19600	19600	18900	18900	18900	18900	20500	20500	20500	20500	18900
	T_{out} [kgf·m]	-	1860	-	2000	2000	1930	1930	1930	1930	2090	2090	2090	2090	1930
	Pro[N]	-	141000	-	151000	159000	171000	179000	179000	179000	179000	179000	179000	179000	179000
	Pro[kgf]	-	14300	-	15400	16200	17400	18200	18200	18200	18200	18200	18200	18200	18200
6235DB	P_i [kW]	-	26.1	-	20.0	-	-	-	-	-	-	-	-	-	-
	T_{out} [N·m]	-	18700	-	19600	-	-	-	-	-	-	-	-	-	-
	T_{out} [kgf·m]	-	1910	-	2000	-	-	-	-	-	-	-	-	-	-
	Pro[N]	-	141000	-	151000	-	-	-	-	-	-	-	-	-	-
	Pro[kgf]	-	14300	-	15400	-	-	-	-	-	-	-	-	-	-
Frame Size	Ratio[Z]	104	121	143	165	195	231	273	319	377	473	559	649	731	841
	n_2 [r/min]	13.9	12.0	10.1	8.79	7.44	6.28	5.31	4.55	3.85	3.07	2.59	2.23	1.98	1.72

Note: 1. Allowable radial load Pro is the value at the midpoint of the output shaft. Refer to pages F-11~12 when radial load is off the midpoint of output shaft and for checking thrust load.

2. Refer to pages F-15~16 for allowable radial load for input shaft.

Selection Tables 6000 Series Reducer

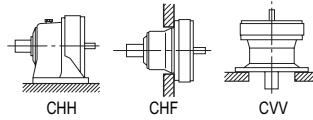

Input Speed $n_1 = 1450$ r/min

1.45	1.16	0.980	0.784	0.702	0.572	0.476	0.417	0.327	0.282	0.235	0.192	n_2 [r/min]	Dim. Page	Frame Size
1003	1247	1479	1849	2065	2537	3045	3481	4437	5133	6177	7569	Ratio[Z]		
-	-	-	-	-	-	-	-	-	-	-	-	P_i [kW]	CHH C-75 CHF C-80 CVW C-87	6185DB
-	-	-	-	-	-	-	-	-	-	-	-	T_{OUT} [N·m]		
-	-	-	-	-	-	-	-	-	-	-	-	T_{OUT} [kgf·m]		
-	-	-	-	-	-	-	-	-	-	-	-	Prof [N]		
-	-	-	-	-	-	-	-	-	-	-	-	Prof [kgf]		
1.07	0.863	0.750	0.750	0.750	0.750	0.750	0.750	0.750	0.750	0.750	0.750	P_i [kW]	CHH C-75 CHF C-80 CVW C-87	6190DA
6380	6380	6380	6380	6380	6380	6380	6380	6380	6380	6380	6380	T_{OUT} [N·m]		
650	650	650	650	650	650	650	650	650	650	650	650	T_{OUT} [kgf·m]		
58600	59000	58900	59000	58600	58600	58900	58600	58900	58900	58900	58900	Prof [N]		
5970	6010	6000	6010	5970	5970	6000	5970	6000	6000	6000	6000	Prof [kgf]		
-	-	-	-	-	-	-	-	-	-	-	-	P_i [kW]	CHH C-75 CHF C-80 CVW C-87	6190DB
-	-	-	-	-	-	-	-	-	-	-	-	T_{OUT} [N·m]		
-	-	-	-	-	-	-	-	-	-	-	-	T_{OUT} [kgf·m]		
-	-	-	-	-	-	-	-	-	-	-	-	Prof [N]		
-	-	-	-	-	-	-	-	-	-	-	-	Prof [kgf]		
1.34	1.08	0.908	0.750	0.750	0.750	0.750	0.750	0.750	0.750	0.750	0.750	P_i [kW]	CHH C-75 CHF C-80 CVW C-87	6195DA
7960	7960	7960	7960	7960	7960	7960	7960	7960	7960	7960	7960	T_{OUT} [N·m]		
811	811	811	811	811	811	811	811	811	811	811	811	T_{OUT} [kgf·m]		
58100	59000	58400	59000	58100	58100	58400	58100	58400	58400	58400	58400	Prof [N]		
5930	6010	5950	6010	5930	5930	5950	5930	5950	5950	5950	5950	Prof [kgf]		
-	-	-	-	-	-	-	-	-	-	-	-	P_i [kW]	CHH C-75 CHF C-80 CVW C-87	6195DB
-	-	-	-	-	-	-	-	-	-	-	-	T_{OUT} [N·m]		
-	-	-	-	-	-	-	-	-	-	-	-	T_{OUT} [kgf·m]		
-	-	-	-	-	-	-	-	-	-	-	-	Prof [N]		
-	-	-	-	-	-	-	-	-	-	-	-	Prof [kgf]		
2.20	1.50	1.50	1.50	1.50	0.750	0.750	0.750	0.750	0.750	0.750	0.750	P_i [kW]	CHH C-75 CHF C-80 CVW C-87	6205DA
9300	9300	8760	9300	9300	9300	8760	9300	8760	9300	8760	8760	T_{OUT} [N·m]		
948	948	893	948	948	948	893	948	893	948	893	893	T_{OUT} [kgf·m]		
84100	84100	84100	84100	84100	84100	84100	84100	84100	84100	84100	84100	Prof [N]		
8570	8570	8570	8570	8570	8570	8570	8570	8570	8570	8570	8570	Prof [kgf]		
2.20	-	1.50	-	-	-	-	-	-	-	-	-	P_i [kW]	CHH C-75 CHF C-80 CVW C-87	6205DB
9300	-	8760	-	-	-	-	-	-	-	-	-	T_{OUT} [N·m]		
948	-	893	-	-	-	-	-	-	-	-	-	T_{OUT} [kgf·m]		
84100	-	84100	-	-	-	-	-	-	-	-	-	Prof [N]		
8570	-	8570	-	-	-	-	-	-	-	-	-	Prof [kgf]		
2.20	2.20	1.50	1.50	1.50	1.50	1.50	1.50	1.50	1.50	1.50	1.50	P_i [kW]	CHH C-75 CHF C-80 CVW C-87	6215DA
12700	12700	11300	12700	12700	12700	11300	12700	11300	12700	11300	11300	T_{OUT} [N·m]		
1290	1290	1150	1290	1290	1290	1150	1290	1150	1290	1150	1150	T_{OUT} [kgf·m]		
104000	104000	104000	104000	104000	104000	104000	104000	104000	104000	104000	104000	Prof [N]		
10600	10600	10600	10600	10600	10600	10600	10600	10600	10600	10600	10600	Prof [kgf]		
-	-	-	-	-	-	-	-	-	-	-	-	P_i [kW]	CHH C-75 CHF C-80 CVW C-87	6215DB
-	-	-	-	-	-	-	-	-	-	-	-	T_{OUT} [N·m]		
-	-	-	-	-	-	-	-	-	-	-	-	T_{OUT} [kgf·m]		
-	-	-	-	-	-	-	-	-	-	-	-	Prof [N]		
-	-	-	-	-	-	-	-	-	-	-	-	Prof [kgf]		
2.67	2.20	2.20	1.50	1.50	1.50	1.50	1.50	1.50	1.50	1.50	1.50	P_i [kW]	CHH C-75 CHF C-80 CVW C-87	6225DA
15900	16000	15100	16000	15900	15900	15100	15900	15100	15900	15100	15100	T_{OUT} [N·m]		
1620	1630	1540	1630	1620	1620	1540	1620	1540	1620	1540	1540	T_{OUT} [kgf·m]		
145000	145000	145000	145000	145000	145000	145000	145000	145000	145000	145000	145000	Prof [N]		
14800	14800	14800	14800	14800	14800	14800	14800	14800	14800	14800	14800	Prof [kgf]		
-	-	-	-	-	-	-	-	-	-	-	-	P_i [kW]	CHH C-75 CHF C-80 CVW C-87	6225DB
-	-	-	-	-	-	-	-	-	-	-	-	T_{OUT} [N·m]		
-	-	-	-	-	-	-	-	-	-	-	-	T_{OUT} [kgf·m]		
-	-	-	-	-	-	-	-	-	-	-	-	Prof [N]		
-	-	-	-	-	-	-	-	-	-	-	-	Prof [kgf]		
3.45	2.77	2.20	2.20	2.20	2.20	2.20	2.20	2.20	2.20	2.20	2.20	P_i [kW]	CHH C-75 CHF C-80 CVW C-87	6235DA
20500	20500	17200	20500	20500	20500	17200	20500	17200	20500	17200	17200	T_{OUT} [N·m]		
2090	2090	1750	2090	2090	2090	1750	2090	1750	2090	1750	1750	T_{OUT} [kgf·m]		
179000	179000	179000	179000	179000	179000	179000	179000	179000	179000	179000	179000	Prof [N]		
18200	18200	18200	18200	18200	18200	18200	18200	18200	18200	18200	18200	Prof [kgf]		
-	-	-	-	-	-	-	-	-	-	-	-	P_i [kW]	CHH C-75 CHF C-80 CVW C-87	6235DB
-	-	-	-	-	-	-	-	-	-	-	-	T_{OUT} [N·m]		
-	-	-	-	-	-	-	-	-	-	-	-	T_{OUT} [kgf·m]		
-	-	-	-	-	-	-	-	-	-	-	-	Prof [N]		
-	-	-	-	-	-	-	-	-	-	-	-	Prof [kgf]		
1003	1247	1479	1849	2065	2537	3045	3481	4437	5133	6177	7569	Ratio[Z]	Dim. Page	Frame Size
1.45	1.16	0.980	0.784	0.702	0.572	0.476	0.417	0.327	0.282	0.235	0.192	n_2 [r/min]		

Note: 3. Necessary input power for starting is printed in bold face. Do not exceed allowable output torque after startup.

REDUCERS
Selection Tables
Ratio 104, 121 - 7569

Selection Tables 6000 Series Reducer

Double Reduction Ratio 104,121 ~ 7569 Frame Size: 6245DA ~ 6275DA

Input Speed	$n_1 = 1450$ r/min	n_1 : Input Speed [r/min]	T_{out} : Allowable output torque [N·m, kgf·m]
		n_2 : Output Speed [r/min]	Pro: Allowable output shaft radial load [N, kgf]
		P_i : Allowable input power [kW]	*Consult us for Pro of CNF and CHF type.

Frame Size	n_2 [r/min]	13.9	12.0	10.1	8.79	7.44	6.28	5.31	4.55	3.85	3.07	2.59	2.23	1.98	1.72
	Ratio[Z]	104	121	143	165	195	231	273	319	377	473	559	649	731	841
6245DA	P_i [kW]	-	-	-	25.4	22.7	18.8	15.9	13.6	11.5	9.20	7.79	6.71	5.95	5.18
	T_{out} [N·m]	-	-	-	24800	26200	25800	25800	25800	25800	25800	25800	25800	25800	25800
	T_{out} [kgf·m]	-	-	-	2530	2680	2630	2630	2630	2630	2630	2630	2630	2630	2630
	Pro[N]	-	-	-	168000	177000	189000	199000	208000	208000	208000	208000	208000	208000	208000
	Pro[kgf]	-	-	-	17100	18000	19300	20300	21200	21200	21200	21200	21200	21200	21200
6245DB	P_i [kW]	-	28.6	-	26.8	22.7	18.8	-	-	-	-	-	-	-	-
	T_{out} [N·m]	-	20500	-	26200	26200	25800	-	-	-	-	-	-	-	-
	T_{out} [kgf·m]	-	2090	-	2680	2680	2630	-	-	-	-	-	-	-	-
	Pro[N]	-	156000	-	168000	177000	189000	-	-	-	-	-	-	-	-
	Pro[kgf]	-	15900	-	17100	18000	19300	-	-	-	-	-	-	-	-
6255DA	P_i [kW]	-	31.8	-	31.8	27.0	22.6	19.2	17.2	14.5	12.3	10.4	8.97	7.96	6.51
	T_{out} [N·m]	-	22800	-	31100	31200	31000	31000	32500	32500	34500	34500	34500	34500	32500
	T_{out} [kgf·m]	-	2330	-	3170	3180	3160	3160	3310	3310	3520	3520	3520	3520	3310
	Pro[N]	-	192000	-	206000	216000	231000	243000	255000	258000	258000	258000	258000	258000	258000
	Pro[kgf]	-	19600	-	21000	22100	23500	24700	26000	26300	26300	26300	26300	26300	26300
6255DB	P_i [kW]	-	38.3	-	31.9	27.0	-	-	-	-	-	-	-	-	-
	T_{out} [N·m]	-	27500	-	31200	31200	-	-	-	-	-	-	-	-	-
	T_{out} [kgf·m]	-	2800	-	3180	3180	-	-	-	-	-	-	-	-	-
	Pro[N]	-	191000	-	206000	216000	-	-	-	-	-	-	-	-	-
	Pro[kgf]	-	19500	-	21000	22100	-	-	-	-	-	-	-	-	-
6265DA	P_i [kW]	-	43.7	-	44.7	37.8	33.6	28.4	24.3	20.6	16.4	13.9	12.0	10.6	9.23
	T_{out} [N·m]	-	31300	-	43700	43700	46000	46000	46000	46000	46000	46000	46000	46000	46000
	T_{out} [kgf·m]	-	3190	-	4460	4460	4690	4690	4690	4690	4690	4690	4690	4690	4690
	Pro[N]	-	234000	-	250000	263000	276000	276000	276000	276000	276000	276000	276000	276000	276000
	Pro[kgf]	-	23800	-	25500	26800	28100	28100	28100	28100	28100	28100	28100	28100	28100
6275DA	P_i [kW]	-	-	-	-	-	-	-	36.1	30.5	24.3	20.6	17.7	15.7	13.7
	T_{out} [N·m]	-	-	-	-	-	-	-	68200	68200	68200	68200	68200	68200	68200
	T_{out} [kgf·m]	-	-	-	-	-	-	-	6950	6950	6950	6950	6950	6950	6950
	Pro[N]	-	-	-	-	-	-	-	248000	248000	248000	248000	248000	248000	248000
	Pro[kgf]	-	-	-	-	-	-	-	25300	25300	25300	25300	25300	25300	25300
Frame Size	Ratio[Z]	104	121	143	165	195	231	273	319	377	473	559	649	731	841
	n_2 [r/min]	13.9	12.0	10.1	8.79	7.44	6.28	5.31	4.55	3.85	3.07	2.59	2.23	1.98	1.72

Selection Tables
Ratio 104,121 ~ 7569
REDUCERS

Note: 1. Allowable radial load Pro is the value at the midpoint of the output shaft. Refer to pages F-11~12 when radial load is off the midpoint of output shaft and for checking thrust load.
2. Refer to pages F-15~16 for allowable radial load for input shaft.

Selection Tables 6000 Series Reducer

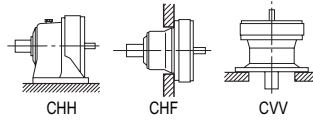

Input Speed	$n_1 = 1450$ r/min
-------------	--------------------

												n_2 [r/min]	Dim. Page	Frame Size
1.45	1.16	0.980	0.784	0.702	0.572	0.476	0.417	0.327	0.282	0.235	0.192	Ratio[Z]		
1003	1247	1479	1849	2065	2537	3045	3481	4437	5133	6177	7569	P_i [kW]	CHH C-75 CHF C-80 CVW C-87	6245DA
4.34	3.49	2.58	2.35	2.20	2.20	2.20	2.20	2.20	2.20	2.20	2.20	T_{OUT} [N•m]		
25800	25800	22600	25800	25800	25800	22600	25800	22600	25800	22600	22600	T_{OUT} [kgf•m]		
2630	2630	2310	2630	2630	2630	2310	2630	2310	2630	2310	2310	Prof[N]		
208000	208000	208000	208000	208000	208000	208000	208000	208000	208000	208000	208000	Prof[kgf]		
21200	21200	21200	21200	21200	21200	21200	21200	21200	21200	21200	21200	P_i [kW]	CHH C-75 CHF C-80 CVW C-87	6245DB
-	-	-	-	-	-	-	-	-	-	-	-	T_{OUT} [N•m]		
-	-	-	-	-	-	-	-	-	-	-	-	T_{OUT} [kgf•m]		
-	-	-	-	-	-	-	-	-	-	-	-	Prof[N]		
-	-	-	-	-	-	-	-	-	-	-	-	Prof[kgf]		
5.80	4.67	3.70	3.70	3.70	3.70	3.70	3.70	3.70	3.70	3.70	3.70	P_i [kW]	CHH C-75 CHF C-80 CVW C-87	6255DA
34500	34500	31000	34500	34500	34500	31000	34500	31000	34500	31000	31000	T_{OUT} [N•m]		
3520	3520	3160	3520	3520	3520	3160	3520	3160	3520	3160	3160	T_{OUT} [kgf•m]		
258000	258000	258000	258000	258000	258000	258000	258000	258000	258000	258000	258000	Prof[N]		
26300	26300	26300	26300	26300	26300	26300	26300	26300	26300	26300	26300	Prof[kgf]		
-	-	-	-	-	-	-	-	-	-	-	-	P_i [kW]	CHH C-75 CHF C-80 CVW C-87	6255DB
-	-	-	-	-	-	-	-	-	-	-	-	T_{OUT} [N•m]		
-	-	-	-	-	-	-	-	-	-	-	-	T_{OUT} [kgf•m]		
-	-	-	-	-	-	-	-	-	-	-	-	Prof[N]		
-	-	-	-	-	-	-	-	-	-	-	-	Prof[kgf]		
7.74	6.22	5.50	5.50	5.50	5.50	5.50	5.50	5.50	5.50	5.50	5.50	P_i [kW]	CHH C-75 CHF C-80 CVW C-87	6265DA
46000	46000	44000	46000	46000	46000	44000	46000	44000	46000	44000	44000	T_{OUT} [N•m]		
4690	4690	4490	4690	4690	4690	4490	4690	4490	4690	4490	4490	T_{OUT} [kgf•m]		
276000	276000	276000	276000	276000	276000	276000	276000	276000	276000	276000	276000	Prof[N]		
28100	28100	28100	28100	28100	28100	28100	28100	28100	28100	28100	28100	Prof[kgf]		
11.5	9.23	7.78	7.50	7.50	7.50	7.50	7.50	7.50	7.50	7.50	7.50	P_i [kW]	CHH C-75 CVW C-87	6275DA
68200	68200	68200	68200	68200	68200	68200	68200	68200	68200	68200	68200	T_{OUT} [N•m]		
6950	6950	6950	6950	6950	6950	6950	6950	6950	6950	6950	6950	T_{OUT} [kgf•m]		
248000	248000	245000	248000	248000	248000	245000	248000	245000	245000	245000	245000	Prof[N]		
25300	25300	25000	25300	25300	25300	25000	25300	25000	25000	25000	25000	Prof[kgf]		
1003	1247	1479	1849	2065	2537	3045	3481	4437	5133	6177	7569	Ratio[Z]	Dim. Page	Frame Size
1.45	1.16	0.980	0.784	0.702	0.572	0.476	0.417	0.327	0.282	0.235	0.192	n_2 [r/min]		

REDUCERS
Selection Tables
Ratio 104, 121 - 7569

Note: 3. Necessary input power for starting is printed in bold face. Do not exceed allowable output torque after startup.

Selection Tables 6000 Series Reducer

Double Reduction Ratio 104,121 ~ 7569 Frame Size: 6060DA ~ 6130DA

Input Speed	$n_1 = 1750$ r/min	n_1 : Input Speed [r/min]	T_{out} : Allowable output torque [N·m, kgf·m]
		n_2 : Output Speed [r/min]	Pro: Allowable output shaft radial load [N, kgf]
		P_i : Allowable input power [kW]	*Consult us for Pro of CNF and CHF type.

Frame Size	n_2 [r/min]	16.8	14.5	12.2	10.6	8.97	7.58	6.41	5.49	4.64	3.70	3.13	2.70	2.39	2.08	
	Ratio[Z]	104	121	143	165	195	231	273	319	377	473	559	649	731	841	
6060DA	P_i [kW]	0.100	0.100	0.100	0.100	0.100	0.100	0.100	0.100	0.100	0.100	0.100	-	0.100	0.100	
	T_{out} [N·m]	24.0	24.0	24.0	24.0	24.0	24.0	24.0	24.0	24.0	24.0	24.0	-	24.0	24.0	
	T_{out} [kgf·m]	2.45	2.45	2.45	2.45	2.45	2.45	2.45	2.45	2.45	2.45	2.45	-	2.45	2.45	
	Pro [N]	1180	1180	1180	1180	1180	1180	1180	1180	1180	1180	1180	-	1180	1180	
	Pro [kgf]	120	120	120	120	120	120	120	120	120	120	120	-	120	120	
6065DA	P_i [kW]	0.100	0.100	0.100	0.100	0.100	0.100	0.100	0.100	0.100	0.100	0.100	-	0.100	0.100	
	T_{out} [N·m]	30.0	30.0	30.0	30.0	30.0	30.0	30.0	30.0	30.0	30.0	30.0	-	30.0	30.0	
	T_{out} [kgf·m]	3.06	3.06	3.06	3.06	3.06	3.06	3.06	3.06	3.06	3.06	3.06	-	3.06	3.06	
	Pro [N]	1180	1140	1180	1180	1180	1180	1180	1180	1180	1180	1180	-	1180	1180	
	Pro [kgf]	120	116	120	120	120	120	120	120	120	120	120	-	120	120	
6070DA	P_i [kW]	0.100	0.100	0.100	0.100	0.100	0.100	0.100	0.100	0.100	0.100	0.100	0.100	0.100	0.100	
	T_{out} [N·m]	45.0	45.0	45.0	45.0	45.0	45.0	45.0	45.0	45.0	45.0	45.0	45.0	45.0	45.0	
	T_{out} [kgf·m]	4.59	4.59	4.59	4.59	4.59	4.59	4.59	4.59	4.59	4.59	4.59	4.59	4.59	4.59	
	Pro [N]	1770	1770	1770	1770	1770	1770	1770	1770	1770	1770	1770	1770	1770	1770	
	Pro [kgf]	180	180	180	180	180	180	180	180	180	180	180	180	180	180	
6075DA	P_i [kW]	0.117	0.100	0.100	0.100	0.100	0.100	0.100	0.100	0.100	0.100	0.100	0.100	0.100	0.100	
	T_{out} [N·m]	60.0	50.8	60.0	60.0	60.0	60.0	60.0	60.0	60.0	60.0	60.0	57.4	60.0	60.0	
	T_{out} [kgf·m]	6.12	5.18	6.12	6.12	6.12	6.12	6.12	6.12	6.12	6.12	6.12	5.85	6.12	6.12	
	Pro [N]	1770	1770	1770	1770	1770	1770	1770	1770	1770	1770	1660	1660	1580	1660	1770
	Pro [kgf]	180	180	180	180	180	180	180	180	180	180	169	169	161	169	180
6090DA	P_i [kW]	0.294	0.252	0.214	0.185	0.157	0.132	0.112	0.100	0.100	0.100	0.100	0.100	0.100	0.100	
	T_{out} [N·m]	150	150	150	150	150	150	150	150	150	150	150	146	150	150	
	T_{out} [kgf·m]	15.3	15.3	15.3	15.3	15.3	15.3	15.3	15.3	15.3	15.3	15.3	14.9	15.3	15.3	
	Pro [N]	3340	3340	3340	3340	3340	3340	3340	3290	3290	3310	3310	3300	3310	3290	
	Pro [kgf]	340	340	340	340	340	340	340	336	336	338	338	336	338	336	
6095DA	P_i [kW]	0.354	0.270	0.261	0.247	0.209	0.176	0.149	0.128	0.108	0.100	0.100	-	0.100	0.100	
	T_{out} [N·m]	181	160	183	200	200	200	200	200	200	200	200	-	200	200	
	T_{out} [kgf·m]	18.4	16.4	18.7	20.4	20.4	20.4	20.4	20.4	20.4	20.4	20.4	-	20.4	20.4	
	Pro [N]	3340	3340	3340	3340	3340	3340	3340	3200	3200	3220	3220	-	3220	3200	
	Pro [kgf]	340	340	340	340	340	340	340	326	326	328	328	-	328	326	
6100DA	P_i [kW]	0.429	0.421	0.356	0.308	0.261	0.220	0.186	0.160	0.135	0.108	0.100	0.100	0.100	0.100	
	T_{out} [N·m]	219	250	250	250	250	250	250	250	250	250	250	250	250	250	
	T_{out} [kgf·m]	22.4	25.5	25.5	25.5	25.5	25.5	25.5	25.5	25.5	25.5	25.5	25.5	25.5	25.5	
	Pro [N]	5400	5400	5400	5400	5400	5400	5400	5400	5400	5400	5400	5400	5400	5400	
	Pro [kgf]	550	550	550	550	550	550	550	550	550	550	550	550	550	550	
6105DA	P_i [kW]	0.429	0.429	0.427	0.370	0.313	0.264	0.224	0.191	0.162	0.129	0.109	0.100	0.100	0.100	
	T_{out} [N·m]	219	255	300	300	300	300	300	300	300	300	300	296	300	300	
	T_{out} [kgf·m]	22.4	26.0	30.6	30.6	30.6	30.6	30.6	30.6	30.6	30.6	30.6	30.2	30.6	30.6	
	Pro [N]	5400	5400	5400	5400	5400	5400	5400	5400	5400	5400	5400	5090	5400	5400	
	Pro [kgf]	550	550	550	550	550	550	550	550	550	550	550	519	550	550	
6120DA	P_i [kW]	-	-	0.429	0.429	0.429	0.429	0.389	0.332	0.281	0.226	0.191	0.165	0.146	0.126	
	T_{out} [N·m]	-	-	302	348	411	487	522	520	520	525	525	525	525	520	
	T_{out} [kgf·m]	-	-	30.7	35.5	41.9	49.7	53.2	53.0	53.0	53.5	53.5	53.5	53.5	53.0	
	Pro [N]	-	-	9810	9810	9810	9810	9810	9810	9810	9810	9810	9810	9810	9810	
	Pro [kgf]	-	-	1000	1000	1000	1000	1000	1000	1000	1000	1000	1000	1000	1000	
6120DB	P_i [kW]	1.03	0.883	0.748	0.648	0.548	0.460	-	-	-	-	-	-	-	-	
	T_{out} [N·m]	525	525	525	525	525	522	-	-	-	-	-	-	-	-	
	T_{out} [kgf·m]	53.5	53.5	53.5	53.5	53.5	53.2	-	-	-	-	-	-	-	-	
	Pro [N]	9810	9810	9810	9810	9810	9810	-	-	-	-	-	-	-	-	
	Pro [kgf]	1000	1000	1000	1000	1000	1000	-	-	-	-	-	-	-	-	
6125DA	P_i [kW]	-	-	-	-	-	0.429	0.429	0.402	0.340	0.271	0.229	0.198	0.175	0.153	
	T_{out} [N·m]	-	-	-	-	-	487	576	630	630	630	630	630	630	630	
	T_{out} [kgf·m]	-	-	-	-	-	49.7	58.7	64.2	64.2	64.2	64.2	64.2	64.2	64.2	
	Pro [N]	-	-	-	-	-	9810	9810	9810	9810	9810	9810	9810	9810	9810	
	Pro [kgf]	-	-	-	-	-	1000	1000	1000	1000	1000	1000	1000	1000	1000	
6125DB	P_i [kW]	1.23	1.05	0.897	0.777	0.658	0.555	0.470	0.402	-	-	-	-	-	-	
	T_{out} [N·m]	630	622	630	630	630	630	630	630	-	-	-	-	-	-	
	T_{out} [kgf·m]	64.2	63.4	64.2	64.2	64.2	64.2	64.2	64.2	-	-	-	-	-	-	
	Pro [N]	9810	9810	9810	9810	9810	9810	9810	9810	-	-	-	-	-	-	
	Pro [kgf]	1000	1000	1000	1000	1000	1000	1000	1000	-	-	-	-	-	-	
6130DA	P_i [kW]	-	-	-	-	-	-	0.429	0.429	0.421	0.336	0.284	0.286	0.217	0.200	
	T_{out} [N·m]	-	-	-	-	-	-	576	673	780	780	780	912	780	780	
	T_{out} [kgf·m]	-	-	-	-	-	-	58.7	68.6	79.5	79.5	79.5	93.0	79.5	79.5	
	Pro [N]	-	-	-	-	-	-	14700	14700	14700	14700	14700	14700	14700	14700	
	Pro [kgf]	-	-	-	-	-	-	1500	1500	1500	1500	1500	1500	1500	1500	

Note: 1. Allowable radial load Pro is the value at the midpoint of the output shaft. Refer to pages F-11~12 when radial load is off the midpoint of output shaft and for checking thrust load.

2. Refer to pages F-15~16 for allowable radial load for input shaft.

Selection Tables
Ratio 104,121 ~ 7569
REDUCERS

Selection Tables 6000 Series Reducer

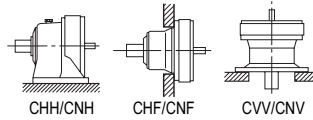

Input Speed	$n_1 = 1750$ r/min
-------------	--------------------

1.74	1.40	1.18	0.946	0.847	0.690	0.575	0.503	0.394	0.341	0.283	0.231	n_2 [r/min]	Dim. Page	Frame Size
1003	1247	1479	1849	2065	2537	3045	3481	4437	5133	6177	7569	Ratio[Z]		
-	0.100	-	0.100	-	-	-	-	-	-	-	-	P_i [kW]	CNH C-73 CNF C-78 CNV C-85	6060DA
-	24.0	-	24.0	-	-	-	-	-	-	-	-	T_{OUT} [N•m]		
-	2.45	-	2.45	-	-	-	-	-	-	-	-	T_{OUT} [kgf•m]		
-	1180	-	1180	-	-	-	-	-	-	-	-	Prof[N]		
-	120	-	120	-	-	-	-	-	-	-	-	Prof[kgf]		
-	0.100	-	0.100	-	-	-	-	-	-	-	-	P_i [kW]	CNH C-73 CNF C-78 CNV C-85	6065DA
-	30.0	-	30.0	-	-	-	-	-	-	-	-	T_{OUT} [N•m]		
-	3.06	-	3.06	-	-	-	-	-	-	-	-	T_{OUT} [kgf•m]		
-	1180	-	1180	-	-	-	-	-	-	-	-	Prof[N]		
-	120	-	120	-	-	-	-	-	-	-	-	Prof[kgf]		
0.100	0.100	-	0.100	0.100	0.100	-	-	-	-	-	-	P_i [kW]	CNH C-73 CNF C-78 CNV C-85	6070DA
45.0	45.0	-	45.0	45.0	45.0	-	-	-	-	-	-	T_{OUT} [N•m]		
4.59	4.59	-	4.59	4.59	4.59	-	-	-	-	-	-	T_{OUT} [kgf•m]		
1770	1770	-	1770	1770	1770	-	-	-	-	-	-	Prof[N]		
180	180	-	180	180	180	-	-	-	-	-	-	Prof[kgf]		
0.100	0.100	-	0.100	0.100	0.100	-	-	-	-	-	-	P_i [kW]	CNH C-73 CNF C-78 CNV C-85	6075DA
57.4	60.0	-	60.0	57.4	57.4	-	-	-	-	-	-	T_{OUT} [N•m]		
5.85	6.12	-	6.12	5.85	5.85	-	-	-	-	-	-	T_{OUT} [kgf•m]		
1580	1660	-	1660	1580	1580	-	-	-	-	-	-	Prof[N]		
161	169	-	169	161	161	-	-	-	-	-	-	Prof[kgf]		
0.100	0.100	0.100	0.100	0.100	0.100	0.100	0.100	0.100	0.100	-	-	P_i [kW]	CNH C-73 CNF C-78 CNV C-85	6090DA
146	150	150	150	146	146	150	146	150	150	-	-	T_{OUT} [N•m]		
14.9	15.3	15.3	15.3	14.9	14.9	15.3	14.9	15.3	15.3	-	-	T_{OUT} [kgf•m]		
3300	3310	3310	3310	3300	3300	3310	3300	3310	3310	-	-	Prof[N]		
336	338	338	338	336	336	338	336	338	338	-	-	Prof[kgf]		
-	0.100	0.100	0.100	-	-	0.100	-	0.100	0.100	-	-	P_i [kW]	CNH C-73 CNF C-78 CNV C-85	6095DA
-	200	193	200	-	-	192	-	192	192	-	-	T_{OUT} [N•m]		
-	20.4	19.6	20.4	-	-	19.6	-	19.6	19.6	-	-	T_{OUT} [kgf•m]		
-	3220	3240	3220	-	-	3240	-	3240	3240	-	-	Prof[N]		
-	328	330	328	-	-	330	-	330	330	-	-	Prof[kgf]		
0.100	0.100	0.100	0.100	0.100	0.100	0.100	0.100	0.100	0.100	-	-	P_i [kW]	CNH C-73 CNF C-78 CNV C-85	6100DA
250	250	250	250	250	250	250	250	250	250	-	-	T_{OUT} [N•m]		
25.5	25.5	25.5	25.5	25.5	25.5	25.5	25.5	25.5	25.5	-	-	T_{OUT} [kgf•m]		
5400	5400	5400	5400	5400	5400	5400	5400	5400	5400	-	-	Prof[N]		
550	550	550	550	550	550	550	550	550	550	-	-	Prof[kgf]		
0.100	0.100	0.100	0.100	0.100	0.100	0.100	0.100	0.100	0.100	-	-	P_i [kW]	CNH C-73 CNF C-78 CNV C-85	6105DA
296	300	300	300	296	296	300	296	300	300	-	-	T_{OUT} [N•m]		
30.2	30.6	30.6	30.6	30.2	30.2	30.6	30.2	30.6	30.6	-	-	T_{OUT} [kgf•m]		
5090	5400	4780	5400	5090	5090	4780	5090	4780	4780	-	-	Prof[N]		
519	550	488	550	519	519	488	519	488	488	-	-	Prof[kgf]		
0.107	0.100	0.100	0.100	0.100	0.100	0.100	0.100	0.100	0.100	-	-	P_i [kW]	CNH C-73 CNF C-78 CNV C-85	6120DA
525	525	525	525	525	525	525	525	525	525	-	-	T_{OUT} [N•m]		
53.5	53.5	53.5	53.5	53.5	53.5	53.5	53.5	53.5	53.5	-	-	T_{OUT} [kgf•m]		
9810	9810	9780	9810	9810	9810	9780	9810	9780	9780	-	-	Prof[N]		
1000	1000	997	1000	1000	1000	997	1000	997	997	-	-	Prof[kgf]		
-	-	-	-	-	-	-	-	-	-	0.100	0.100	P_i [kW]	CNH C-73 CNF C-78 CNV C-85	6120DB
-	-	-	-	-	-	-	-	-	-	525	525	T_{OUT} [N•m]		
-	-	-	-	-	-	-	-	-	-	53.5	53.5	T_{OUT} [kgf•m]		
-	-	-	-	-	-	-	-	-	-	9780	9780	Prof[N]		
-	-	-	-	-	-	-	-	-	-	997	997	Prof[kgf]		
0.128	0.103	0.100	0.100	0.100	0.100	0.100	0.100	0.100	0.100	-	-	P_i [kW]	CNH C-73 CNF C-78 CNV C-85	6125DA
630	630	630	630	630	630	630	630	630	630	-	-	T_{OUT} [N•m]		
64.2	64.2	64.2	64.2	64.2	64.2	64.2	64.2	64.2	64.2	-	-	T_{OUT} [kgf•m]		
9810	9810	9560	9810	9810	9810	9560	9810	9560	9560	-	-	Prof[N]		
1000	1000	974	1000	1000	1000	974	1000	974	974	-	-	Prof[kgf]		
-	-	-	-	-	-	-	-	-	-	0.100	0.100	P_i [kW]	CNH C-73 CNF C-78 CNV C-85	6125DB
-	-	-	-	-	-	-	-	-	-	630	630	T_{OUT} [N•m]		
-	-	-	-	-	-	-	-	-	-	64.2	64.2	T_{OUT} [kgf•m]		
-	-	-	-	-	-	-	-	-	-	9560	9560	Prof[N]		
-	-	-	-	-	-	-	-	-	-	974	974	Prof[kgf]		
0.200	0.200	0.200	0.200	0.200	0.200	0.200	0.200	0.200	0.200	-	-	P_i [kW]	CHH C-74 CHF C-79 CVV C-86	6130DA
912	780	848	780	912	912	848	912	848	848	-	-	T_{OUT} [N•m]		
93.0	79.5	86.5	79.5	93.0	93.0	86.5	93.0	86.5	86.5	-	-	T_{OUT} [kgf•m]		
14700	14700	14700	14700	14700	14700	14700	14700	14700	14700	-	-	Prof[N]		
1500	1500	1500	1500	1500	1500	1500	1500	1500	1500	-	-	Prof[kgf]		
1003	1247	1479	1849	2065	2537	3045	3481	4437	5133	6177	7569	Ratio[Z]	Dim. Page	Frame Size
1.74	1.40	1.18	0.946	0.847	0.690	0.575	0.503	0.394	0.341	0.283	0.231	n_2 [r/min]		

Note: 3. Necessary input power for starting is printed in bold face. Do not exceed allowable output torque after startup.

REDUCERS
Selection Tables
Ratio 104,121 - 7569

Selection Tables 6000 Series Reducer

Double Reduction Ratio 104,121 ~ 7569 Frame Size: 6130DB ~ 6160DB

Input Speed	$n_1 = 1750$ r/min	n_1 : Input Speed [r/min]	T_{out} : Allowable output torque [N·m, kgf·m]
		n_2 : Output Speed [r/min]	Pro: Allowable output shaft radial load [N, kgf]
		P_i : Allowable input power [kW]	*Consult us for Pro of CNF and CHF type.

Frame Size	n_2 [r/min]	16.8	14.5	12.2	10.6	8.97	7.58	6.41	5.49	4.64	3.70	3.13	2.70	2.39	2.08
	Ratio[Z]	104	121	143	165	195	231	273	319	377	473	559	649	731	841
6130DB	P_i [kW]	1.53	1.31	1.11	0.963	0.814	0.688	0.582	0.498	0.421	-	-	-	-	-
	T_{out} [N·m]	780	780	780	780	780	780	780	780	780	-	-	-	-	-
	T_{out} [kgf·m]	79.5	79.5	79.5	79.5	79.5	79.5	79.5	79.5	79.5	-	-	-	-	-
	Pro[N]	14700	14700	14700	14700	14700	14700	14700	14700	14700	-	-	-	-	-
	Pro[kgf]	1500	1500	1500	1500	1500	1500	1500	1500	1500	-	-	-	-	-
6130DC	P_i [kW]	1.53	-	-	-	-	-	-	-	-	-	-	-	-	-
	T_{out} [N·m]	780	-	-	-	-	-	-	-	-	-	-	-	-	-
	T_{out} [kgf·m]	79.5	-	-	-	-	-	-	-	-	-	-	-	-	-
	Pro[N]	14700	-	-	-	-	-	-	-	-	-	-	-	-	-
	Pro[kgf]	1500	-	-	-	-	-	-	-	-	-	-	-	-	-
6135DA	P_i [kW]	-	-	-	-	-	-	-	0.429	0.429	0.405	0.342	0.329	0.262	0.228
	T_{out} [N·m]	-	-	-	-	-	-	-	673	795	940	940	1050	940	940
	T_{out} [kgf·m]	-	-	-	-	-	-	-	68.6	81.1	95.8	95.8	107	95.8	95.8
	Pro[N]	-	-	-	-	-	-	-	14700	14700	14700	14700	14700	14700	14700
	Pro[kgf]	-	-	-	-	-	-	-	1500	1500	1500	1500	1500	1500	1500
6135DB	P_i [kW]	1.60	1.58	1.34	1.16	0.981	0.829	0.701	0.600	0.508	0.405	-	-	-	-
	T_{out} [N·m]	817	940	940	940	940	940	940	940	940	940	-	-	-	-
	T_{out} [kgf·m]	83.3	95.8	95.8	95.8	95.8	95.8	95.8	95.8	95.8	95.8	-	-	-	-
	Pro[N]	14700	14700	14700	14700	14700	14700	14700	14700	14700	14700	-	-	-	-
	Pro[kgf]	1500	1500	1500	1500	1500	1500	1500	1500	1500	1500	-	-	-	-
6135DC	P_i [kW]	1.84	1.58	-	-	-	-	-	-	-	-	-	-	-	-
	T_{out} [N·m]	940	940	-	-	-	-	-	-	-	-	-	-	-	-
	T_{out} [kgf·m]	95.8	95.8	-	-	-	-	-	-	-	-	-	-	-	-
	Pro[N]	14700	14700	-	-	-	-	-	-	-	-	-	-	-	-
	Pro[kgf]	1500	1500	-	-	-	-	-	-	-	-	-	-	-	-
6140DA	P_i [kW]	-	-	-	-	-	-	-	-	0.429	0.429	0.429	0.384	0.341	0.297
	T_{out} [N·m]	-	-	-	-	-	-	-	-	795	998	1180	1230	1230	1230
	T_{out} [kgf·m]	-	-	-	-	-	-	-	-	81.1	102	120	125	125	125
	Pro[N]	-	-	-	-	-	-	-	-	16000	16000	16000	16000	16000	16000
	Pro[kgf]	-	-	-	-	-	-	-	-	1630	1630	1630	1630	1630	1630
6140DB	P_i [kW]	1.60	1.60	1.60	1.51	1.28	1.08	0.914	0.782	0.662	0.527	0.446	-	-	-
	T_{out} [N·m]	817	950	1120	1230	1230	1230	1230	1230	1230	1230	1230	-	-	-
	T_{out} [kgf·m]	83.3	96.9	114	125	125	125	125	125	125	125	125	-	-	-
	Pro[N]	16000	16000	16000	16000	16000	16000	16000	16000	16000	16000	16000	-	-	-
	Pro[kgf]	1630	1630	1630	1630	1630	1630	1630	1630	1630	1630	1630	-	-	-
6140DC	P_i [kW]	2.40	2.06	1.74	1.51	-	-	-	-	-	-	-	-	-	-
	T_{out} [N·m]	1230	1230	1230	1230	-	-	-	-	-	-	-	-	-	-
	T_{out} [kgf·m]	125	125	125	125	-	-	-	-	-	-	-	-	-	-
	Pro[N]	16000	16000	16000	16000	-	-	-	-	-	-	-	-	-	-
	Pro[kgf]	1630	1630	1630	1630	-	-	-	-	-	-	-	-	-	-
6145DA	P_i [kW]	-	-	-	-	-	-	-	-	-	-	0.429	0.429	0.382	0.302
	T_{out} [N·m]	-	-	-	-	-	-	-	-	-	-	1180	1370	1370	1250
	T_{out} [kgf·m]	-	-	-	-	-	-	-	-	-	-	120	140	140	127
	Pro[N]	-	-	-	-	-	-	-	-	-	-	16000	16000	15700	16000
	Pro[kgf]	-	-	-	-	-	-	-	-	-	-	1630	1630	1600	1630
6145DB	P_i [kW]	-	-	1.60	1.60	1.42	1.18	0.998	0.874	0.740	0.590	0.499	0.430	-	0.332
	T_{out} [N·m]	-	-	1120	1300	1360	1340	1340	1370	1370	1370	1370	1370	-	1370
	T_{out} [kgf·m]	-	-	114	132	138	136	136	140	140	140	140	140	-	140
	Pro[N]	-	-	16000	16000	16000	16000	16000	16000	15800	15800	15700	15700	-	15800
	Pro[kgf]	-	-	1630	1630	1630	1630	1630	1610	1610	1600	1600	1630	-	1610
6145DC	P_i [kW]	2.68	2.17	1.95	1.68	-	-	-	-	-	-	-	-	-	-
	T_{out} [N·m]	1370	1290	1370	1360	-	-	-	-	-	-	-	-	-	-
	T_{out} [kgf·m]	140	132	140	138	-	-	-	-	-	-	-	-	-	-
	Pro[N]	15900	16000	15900	16000	-	-	-	-	-	-	-	-	-	-
	Pro[kgf]	1620	1630	1620	1630	-	-	-	-	-	-	-	-	-	-
6160DA	P_i [kW]	-	-	-	1.60	1.60	1.55	1.31	1.12	0.948	0.747	0.632	0.551	0.483	0.425
	T_{out} [N·m]	-	-	-	1300	1530	1760	1760	1760	1760	1740	1740	1760	1740	1760
	T_{out} [kgf·m]	-	-	-	132	156	179	179	179	179	177	177	179	177	179
	Pro[N]	-	-	-	22100	22100	22100	22100	22100	22100	22100	22100	22100	22100	22100
	Pro[kgf]	-	-	-	2250	2250	2250	2250	2250	2250	2250	2250	2250	2250	2250
6160DB	P_i [kW]	3.36	2.95	2.50	2.17	1.83	1.55	-	-	-	-	-	-	-	-
	T_{out} [N·m]	1710	1760	1760	1760	1760	1760	-	-	-	-	-	-	-	-
	T_{out} [kgf·m]	175	179	179	179	179	179	-	-	-	-	-	-	-	-
	Pro[N]	22100	22100	22100	22100	22100	22100	-	-	-	-	-	-	-	-
	Pro[kgf]	2250	2250	2250	2250	2250	2250	-	-	-	-	-	-	-	-
Frame Size	Ratio[Z]	104	121	143	165	195	231	273	319	377	473	559	649	731	841
	n_2 [r/min]	16.8	14.5	12.2	10.6	8.97	7.58	6.41	5.49	4.64	3.70	3.13	2.70	2.39	2.08

Note: 1. Allowable radial load Pro is the value at the midpoint of the output shaft. Refer to pages F-11~12 when radial load is off the midpoint of output shaft and for checking thrust load.

2. Refer to pages F-15~16 for allowable radial load for input shaft.

Selection Tables 6000 Series Reducer

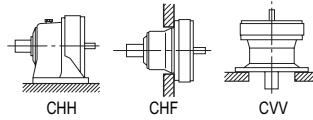

Input Speed $n_1 = 1750$ r/min

												n_2 [r/min]	Dim. Page	Frame Size	
1.74	1.40	1.18	0.946	0.847	0.690	0.575	0.503	0.394	0.341	0.283	0.231	Ratio[Z]			
1003	1247	1479	1849	2065	2537	3045	3481	4437	5133	6177	7569				
-	-	-	-	-	-	-	-	-	-	0.200	0.200	P_i [kW]	CHH C-74	6130DB	
-	-	-	-	-	-	-	-	-	-	848	848	T_{OUT} [N•m]	CHF C-79		
-	-	-	-	-	-	-	-	-	-	86.5	86.5	T_{OUT} [kgf•m]	CW C-86		
-	-	-	-	-	-	-	-	-	-	14700	14700	Prof[N]			
-	-	-	-	-	-	-	-	-	-	-	1500	1500	Prof[kgf]		
-	-	-	-	-	-	-	-	-	-	-	-	P_i [kW]	CHH C-74	6130DC	
-	-	-	-	-	-	-	-	-	-	-	-	T_{OUT} [N•m]	CHF C-79		
-	-	-	-	-	-	-	-	-	-	-	-	T_{OUT} [kgf•m]	CW C-86		
-	-	-	-	-	-	-	-	-	-	-	-	Prof[N]			
-	-	-	-	-	-	-	-	-	-	-	-	Prof[kgf]			
0.213	0.200	0.200	0.200	0.200	0.200	0.200	0.200	0.200	0.200	-	-	P_i [kW]	CHH C-74	6135DA	
1050	940	979	940	1050	1050	979	1050	979	979	-	-	T_{OUT} [N•m]	CHF C-79		
107	95.8	99.8	95.8	107	107	99.8	107	99.8	99.8	-	-	T_{OUT} [kgf•m]	CW C-86		
14700	14700	14700	14700	14700	14700	14700	14700	14700	14700	-	-	Prof[N]			
1500	1500	1500	1500	1500	1500	1500	1500	1500	1500	-	-	Prof[kgf]			
-	-	-	-	-	-	-	-	-	-	0.200	0.200	P_i [kW]	CHH C-74	6135DB	
-	-	-	-	-	-	-	-	-	-	979	979	T_{OUT} [N•m]	CHF C-79		
-	-	-	-	-	-	-	-	-	-	99.8	99.8	T_{OUT} [kgf•m]	CW C-86		
-	-	-	-	-	-	-	-	-	-	14700	14700	Prof[N]			
-	-	-	-	-	-	-	-	-	-	-	1500	1500	Prof[kgf]		
-	-	-	-	-	-	-	-	-	-	-	-	P_i [kW]	CHH C-74	6135DC	
-	-	-	-	-	-	-	-	-	-	-	-	T_{OUT} [N•m]	CHF C-79		
-	-	-	-	-	-	-	-	-	-	-	-	T_{OUT} [kgf•m]	CW C-86		
-	-	-	-	-	-	-	-	-	-	-	-	Prof[N]			
-	-	-	-	-	-	-	-	-	-	-	-	Prof[kgf]			
0.249	0.200	0.200	0.200	0.200	0.200	0.200	0.200	0.200	0.200	-	-	P_i [kW]	CHH C-74	6140DA	
1230	1230	1230	1230	1230	1230	1230	1230	1230	1230	-	-	T_{OUT} [N•m]	CHF C-79		
125	125	125	125	125	125	125	125	125	125	-	-	T_{OUT} [kgf•m]	CW C-86		
16000	16000	16000	16000	16000	16000	16000	16000	16000	16000	-	-	Prof[N]			
1630	1630	1630	1630	1630	1630	1630	1630	1630	1630	-	-	Prof[kgf]			
-	-	-	-	-	-	-	-	-	-	0.200	0.200	P_i [kW]	CHH C-74	6140DB	
-	-	-	-	-	-	-	-	-	-	1230	1230	T_{OUT} [N•m]	CHF C-79		
-	-	-	-	-	-	-	-	-	-	125	125	T_{OUT} [kgf•m]	CW C-86		
-	-	-	-	-	-	-	-	-	-	16000	16000	Prof[N]			
-	-	-	-	-	-	-	-	-	-	-	1630	1630	Prof[kgf]		
-	-	-	-	-	-	-	-	-	-	-	-	P_i [kW]	CHH C-74	6140DC	
-	-	-	-	-	-	-	-	-	-	-	-	T_{OUT} [N•m]	CHF C-79		
-	-	-	-	-	-	-	-	-	-	-	-	T_{OUT} [kgf•m]	CW C-86		
-	-	-	-	-	-	-	-	-	-	-	-	Prof[N]			
-	-	-	-	-	-	-	-	-	-	-	-	Prof[kgf]			
0.278	0.224	0.200	0.200	0.200	0.200	0.200	0.200	0.200	0.200	-	-	P_i [kW]	CHH C-74	6145DA	
1370	1370	1250	1370	1370	1370	1250	1370	1250	1250	-	-	T_{OUT} [N•m]	CHF C-79		
140	140	127	140	140	140	127	140	127	127	-	-	T_{OUT} [kgf•m]	CW C-86		
16000	15700	16000	15700	16000	16000	16000	16000	16000	16000	-	-	Prof[N]			
1630	1600	1630	1600	1630	1630	1630	1630	1630	1630	-	-	Prof[kgf]			
-	-	-	-	-	-	-	-	-	-	0.200	0.200	P_i [kW]	CHH C-74	6145DB	
-	-	-	-	-	-	-	-	-	-	1250	1250	T_{OUT} [N•m]	CHF C-79		
-	-	-	-	-	-	-	-	-	-	127	127	T_{OUT} [kgf•m]	CW C-86		
-	-	-	-	-	-	-	-	-	-	16000	16000	Prof[N]			
-	-	-	-	-	-	-	-	-	-	-	1630	1630	Prof[kgf]		
-	-	-	-	-	-	-	-	-	-	-	-	P_i [kW]	CHH C-74	6145DC	
-	-	-	-	-	-	-	-	-	-	-	-	T_{OUT} [N•m]	CHF C-79		
-	-	-	-	-	-	-	-	-	-	-	-	T_{OUT} [kgf•m]	CW C-86		
-	-	-	-	-	-	-	-	-	-	-	-	Prof[N]			
-	-	-	-	-	-	-	-	-	-	-	-	Prof[kgf]			
0.400	0.400	0.400	0.200	0.200	0.200	0.200	0.200	0.200	0.200	0.200	0.200	P_i [kW]	CHH C-74	6160DA	
1760	1740	1760	1740	1760	1760	1760	1760	1760	1760	1760	1760	T_{OUT} [N•m]	CHF C-79		
179	177	179	177	179	179	179	179	179	179	179	179	T_{OUT} [kgf•m]	CW C-86		
22100	22100	22100	22100	22100	22100	22100	22100	22100	22100	22100	22100	Prof[N]			
2250	2250	2250	2250	2250	2250	2250	2250	2250	2250	2250	2250	Prof[kgf]			
-	-	-	-	-	-	-	-	-	-	-	-	P_i [kW]	CHH C-74	6160DB	
-	-	-	-	-	-	-	-	-	-	-	-	T_{OUT} [N•m]	CHF C-79		
-	-	-	-	-	-	-	-	-	-	-	-	T_{OUT} [kgf•m]	CW C-86		
-	-	-	-	-	-	-	-	-	-	-	-	Prof[N]			
-	-	-	-	-	-	-	-	-	-	-	-	Prof[kgf]			
1003	1247	1479	1849	2065	2537	3045	3481	4437	5133	6177	7569	Ratio[Z]	Dim. Page	Frame Size	
1.74	1.40	1.18	0.946	0.847	0.690	0.575	0.503	0.394	0.341	0.283	0.231	n_2 [r/min]			

Note: 3. Necessary input power for starting is printed in bold face. Do not exceed allowable output torque after startup.

REDUCERS
Selection Tables
Ratio 104, 121 - 7569

Selection Tables 6000 Series Reducer

Double Reduction Ratio 104,121 ~ 7569 Frame Size: 6160DC ~ 6185DA

Input Speed	$n_1 = 1750$ r/min	n_1 : Input Speed [r/min]	T_{out} : Allowable output torque [N·m, kgf·m]
		n_2 : Output Speed [r/min]	Pro: Allowable output shaft radial load [N, kgf]
		P_i : Allowable input power [kW]	*Consult us for Pro of CNF and CHF type.

Frame Size	n_2 [r/min]	16.8	14.5	12.2	10.6	8.97	7.58	6.41	5.49	4.64	3.70	3.13	2.70	2.39	2.08
	Ratio[Z]	104	121	143	165	195	231	273	319	377	473	559	649	731	841
6160DC	P_i [kW]	3.44	2.95	2.50	-	-	-	-	-	-	-	-	-	-	-
	T_{out} [N·m]	1760	1760	1760	-	-	-	-	-	-	-	-	-	-	-
	T_{out} [kgf·m]	179	179	179	-	-	-	-	-	-	-	-	-	-	-
	Pro[N]	22100	22100	22100	-	-	-	-	-	-	-	-	-	-	-
	Pro[kgf]	2250	2250	2250	-	-	-	-	-	-	-	-	-	-	-
6165DA	P_i [kW]	-	-	-	-	1.60	1.60	1.57	1.34	1.13	0.904	0.765	0.659	0.585	0.508
	T_{out} [N·m]	-	-	-	-	1530	1810	2100	2100	2100	2100	2100	2100	2100	2100
	T_{out} [kgf·m]	-	-	-	-	156	185	214	214	214	214	214	214	214	214
	Pro[N]	-	-	-	-	22100	22100	22100	22100	22100	22100	22100	22100	22100	22100
	Pro[kgf]	-	-	-	-	2250	2250	2250	2250	2250	2250	2250	2250	2250	2250
6165DB	P_i [kW]	3.36	3.36	2.99	2.59	2.19	1.85	1.57	-	-	-	-	-	-	-
	T_{out} [N·m]	1710	1990	2100	2100	2100	2100	2100	-	-	-	-	-	-	-
	T_{out} [kgf·m]	175	203	214	214	214	214	214	-	-	-	-	-	-	-
	Pro[N]	22100	22100	22100	22100	22100	22100	22100	-	-	-	-	-	-	-
	Pro[kgf]	2250	2250	2250	2250	2250	2250	2250	-	-	-	-	-	-	-
6165DC	P_i [kW]	4.11	3.53	2.99	2.59	-	-	-	-	-	-	-	-	-	-
	T_{out} [N·m]	2100	2100	2100	2100	-	-	-	-	-	-	-	-	-	-
	T_{out} [kgf·m]	214	214	214	214	-	-	-	-	-	-	-	-	-	-
	Pro[N]	22100	22100	22100	22100	-	-	-	-	-	-	-	-	-	-
	Pro[kgf]	2250	2250	2250	2250	-	-	-	-	-	-	-	-	-	-
6170DA	P_i [kW]	-	-	-	-	-	1.60	1.60	1.60	1.37	1.09	0.922	0.794	0.705	0.613
	T_{out} [N·m]	-	-	-	-	-	1810	2140	2510	2530	2530	2530	2530	2530	2530
	T_{out} [kgf·m]	-	-	-	-	-	185	219	255	258	258	258	258	258	258
	Pro[N]	-	-	-	-	-	29500	29500	29500	29500	29500	29500	29500	29500	29500
	Pro[kgf]	-	-	-	-	-	3010	3010	3010	3010	3010	3010	3010	3010	3010
6170DB	P_i [kW]	-	3.36	3.36	3.12	2.64	2.23	1.89	1.61	-	-	-	-	-	-
	T_{out} [N·m]	-	1990	2360	2530	2530	2530	2530	2530	-	-	-	-	-	-
	T_{out} [kgf·m]	-	203	240	258	258	258	258	258	-	-	-	-	-	-
	Pro[N]	-	29500	29500	29500	29500	29500	29500	29500	-	-	-	-	-	-
	Pro[kgf]	-	3010	3010	3010	3010	3010	3010	3010	-	-	-	-	-	-
6170DC	P_i [kW]	4.95	4.26	3.60	3.12	2.64	2.23	-	-	-	-	-	-	-	-
	T_{out} [N·m]	2530	2530	2530	2530	2530	2530	-	-	-	-	-	-	-	-
	T_{out} [kgf·m]	258	258	258	258	258	258	-	-	-	-	-	-	-	-
	Pro[N]	28600	29500	29500	29500	29500	29500	-	-	-	-	-	-	-	-
	Pro[kgf]	2920	3010	3010	3010	3010	3010	-	-	-	-	-	-	-	-
6175DA	P_i [kW]	-	-	-	-	-	-	1.60	1.60	1.60	1.36	1.15	0.988	0.877	0.763
	T_{out} [N·m]	-	-	-	-	-	-	2140	2510	2960	3150	3150	3150	3150	3150
	T_{out} [kgf·m]	-	-	-	-	-	-	219	255	302	321	321	321	321	321
	Pro[N]	-	-	-	-	-	-	29500	29500	29500	29500	29500	29500	29500	29500
	Pro[kgf]	-	-	-	-	-	-	3010	3010	3010	3010	3010	3010	3010	3010
6175DB	P_i [kW]	-	-	3.36	3.36	3.29	2.78	2.35	2.01	1.70	-	-	-	-	-
	T_{out} [N·m]	-	-	2360	2720	3150	3150	3150	3150	3150	-	-	-	-	-
	T_{out} [kgf·m]	-	-	240	277	321	321	321	321	321	-	-	-	-	-
	Pro[N]	-	-	29500	29500	29500	29500	29500	29500	29500	-	-	-	-	-
	Pro[kgf]	-	-	3010	3010	3010	3010	3010	3010	3010	-	-	-	-	-
6175DC	P_i [kW]	6.17	5.30	4.49	3.89	3.29	2.78	2.35	-	-	-	-	-	-	-
	T_{out} [N·m]	3150	3150	3150	3150	3150	3150	3150	-	-	-	-	-	-	-
	T_{out} [kgf·m]	321	321	321	321	321	321	321	-	-	-	-	-	-	-
	Pro[N]	28300	29500	29500	29500	29500	29500	29500	-	-	-	-	-	-	-
	Pro[kgf]	2880	3010	3010	3010	3010	3010	3010	-	-	-	-	-	-	-
6180DA	P_i [kW]	-	-	-	3.36	3.36	3.36	3.02	2.59	2.19	1.75	1.48	1.27	1.13	0.981
	T_{out} [N·m]	-	-	-	2720	3210	3810	4050	4050	4050	4060	4060	4050	4060	4050
	T_{out} [kgf·m]	-	-	-	277	328	388	413	413	413	414	414	413	414	413
	Pro[N]	-	-	-	41700	41700	41700	41700	41700	41700	41700	41700	41700	41700	41700
	Pro[kgf]	-	-	-	4250	4250	4250	4250	4250	4250	4250	4250	4250	4250	4250
6180DB	P_i [kW]	7.95	6.83	5.78	5.01	4.24	3.57	3.02	2.59	-	-	-	-	-	-
	T_{out} [N·m]	4060	4060	4060	4060	4060	4050	4050	4050	-	-	-	-	-	-
	T_{out} [kgf·m]	414	414	414	414	414	413	413	413	-	-	-	-	-	-
	Pro[N]	37700	40300	41700	41700	41700	41700	41700	41700	-	-	-	-	-	-
	Pro[kgf]	3840	4100	4250	4250	4250	4250	4250	4250	-	-	-	-	-	-
6185DA	P_i [kW]	-	-	-	-	-	3.36	3.36	3.19	2.70	2.15	1.82	1.57	1.39	1.21
	T_{out} [N·m]	-	-	-	-	-	3810	4500	5000	5000	5000	5000	5000	5000	5000
	T_{out} [kgf·m]	-	-	-	-	-	388	459	510	510	510	510	510	510	510
	Pro[N]	-	-	-	-	-	41700	41700	41700	41700	41700	41700	41700	41600	41700
	Pro[kgf]	-	-	-	-	-	4250	4250	4250	4250	4250	4250	4240	4250	4250
Frame Size	Ratio[Z]	104	121	143	165	195	231	273	319	377	473	559	649	731	841
	n_2 [r/min]	16.8	14.5	12.2	10.6	8.97	7.58	6.41	5.49	4.64	3.70	3.13	2.70	2.39	2.08

Note: 1. Allowable radial load Pro is the value at the midpoint of the output shaft. Refer to pages F-11~12 when radial load is off the midpoint of output shaft and for checking thrust load.

2. Refer to pages F-15~16 for allowable radial load for input shaft.

Selection Tables 6000 Series Reducer

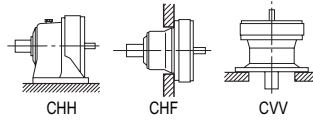

Input Speed	$n_1 = 1750$ r/min
-------------	--------------------

1.74	1.40	1.18	0.946	0.847	0.690	0.575	0.503	0.394	0.341	0.283	0.231	n_2 [r/min]	Dim. Page	Frame Size
1003	1247	1479	1849	2065	2537	3045	3481	4437	5133	6177	7569	Ratio[Z]		
-	-	-	-	-	-	-	-	-	-	-	-	P_i [kW]	CHH C-75 CHF C-80 CVW C-87	6160DC
-	-	-	-	-	-	-	-	-	-	-	-	T_{OUT} [N·m]		
-	-	-	-	-	-	-	-	-	-	-	-	T_{OUT} [kgf·m]		
-	-	-	-	-	-	-	-	-	-	-	-	Prof [N]		
0.426	0.400	0.400	0.400	0.207	0.200	0.200	0.200	0.200	0.200	0.200	0.200	P_i [kW]	CHH C-74 CHF C-79 CVW C-86	6165DA
2100	2100	2050	2100	2100	2100	2050	2100	2050	2050	2050	2050	T_{OUT} [N·m]		
214	214	209	214	214	214	209	214	209	209	209	209	T_{OUT} [kgf·m]		
22100	22100	21800	22100	22100	22100	21800	22100	21800	21800	21800	21800	Prof [N]		
2250	2250	2220	2250	2250	2250	2220	2250	2220	2220	2220	2220	Prof [kgf]		
-	-	-	-	-	-	-	-	-	-	-	-	P_i [kW]	CHH C-74 CHF C-79 CVW C-86	6165DB
-	-	-	-	-	-	-	-	-	-	-	-	T_{OUT} [N·m]		
-	-	-	-	-	-	-	-	-	-	-	-	T_{OUT} [kgf·m]		
-	-	-	-	-	-	-	-	-	-	-	-	Prof [N]		
-	-	-	-	-	-	-	-	-	-	-	-	Prof [kgf]		
-	-	-	-	-	-	-	-	-	-	-	-	P_i [kW]	CHH C-75 CHF C-80 CVW C-87	6165DC
-	-	-	-	-	-	-	-	-	-	-	-	T_{OUT} [N·m]		
-	-	-	-	-	-	-	-	-	-	-	-	T_{OUT} [kgf·m]		
-	-	-	-	-	-	-	-	-	-	-	-	Prof [N]		
-	-	-	-	-	-	-	-	-	-	-	-	Prof [kgf]		
0.514	0.413	0.400	0.400	0.400	0.203	0.200	0.200	0.200	0.200	0.200	0.200	P_i [kW]	CHH C-74 CHF C-79 CVW C-86	6170DA
2530	2530	2530	2530	2530	2530	2530	2530	2530	2530	2530	2530	T_{OUT} [N·m]		
258	258	258	258	258	258	258	258	258	258	258	258	T_{OUT} [kgf·m]		
29500	29500	29500	29500	29500	29500	29500	29500	29500	29500	29500	29500	Prof [N]		
3010	3010	3010	3010	3010	3010	3010	3010	3010	3010	3010	3010	Prof [kgf]		
-	-	-	-	-	-	-	-	-	-	-	-	P_i [kW]	CHH C-74 CHF C-79 CVW C-86	6170DB
-	-	-	-	-	-	-	-	-	-	-	-	T_{OUT} [N·m]		
-	-	-	-	-	-	-	-	-	-	-	-	T_{OUT} [kgf·m]		
-	-	-	-	-	-	-	-	-	-	-	-	Prof [N]		
-	-	-	-	-	-	-	-	-	-	-	-	Prof [kgf]		
-	-	-	-	-	-	-	-	-	-	-	-	P_i [kW]	CHH C-75 CHF C-80 CVW C-87	6170DC
-	-	-	-	-	-	-	-	-	-	-	-	T_{OUT} [N·m]		
-	-	-	-	-	-	-	-	-	-	-	-	T_{OUT} [kgf·m]		
-	-	-	-	-	-	-	-	-	-	-	-	Prof [N]		
-	-	-	-	-	-	-	-	-	-	-	-	Prof [kgf]		
0.639	0.514	0.434	0.400	0.400	0.400	0.211	0.200	0.200	0.200	0.200	0.200	P_i [kW]	CHH C-74 CHF C-79 CVW C-86	6175DA
3150	3150	3150	3150	3150	3150	3150	3150	3150	3150	3150	3150	T_{OUT} [N·m]		
321	321	321	321	321	321	321	321	321	321	321	321	T_{OUT} [kgf·m]		
29500	29500	29500	29500	29500	29500	29500	29500	29500	29500	29500	29500	Prof [N]		
3010	3010	3010	3010	3010	3010	3010	3010	3010	3010	3010	3010	Prof [kgf]		
-	-	-	-	-	-	-	-	-	-	-	-	P_i [kW]	CHH C-74 CHF C-79 CVW C-86	6175DB
-	-	-	-	-	-	-	-	-	-	-	-	T_{OUT} [N·m]		
-	-	-	-	-	-	-	-	-	-	-	-	T_{OUT} [kgf·m]		
-	-	-	-	-	-	-	-	-	-	-	-	Prof [N]		
-	-	-	-	-	-	-	-	-	-	-	-	Prof [kgf]		
-	-	-	-	-	-	-	-	-	-	-	-	P_i [kW]	CHH C-75 CHF C-80 CVW C-87	6175DC
-	-	-	-	-	-	-	-	-	-	-	-	T_{OUT} [N·m]		
-	-	-	-	-	-	-	-	-	-	-	-	T_{OUT} [kgf·m]		
-	-	-	-	-	-	-	-	-	-	-	-	Prof [N]		
-	-	-	-	-	-	-	-	-	-	-	-	Prof [kgf]		
0.822	0.750	0.750	0.447	0.400	0.400	0.400	0.400	0.400	0.400	0.400	0.400	P_i [kW]	CHH C-74 CHF C-79 CVW C-86	6180DA
4050	4060	4060	4060	4050	4050	4060	4050	4060	4060	4060	4060	T_{OUT} [N·m]		
413	414	414	414	413	413	414	413	414	414	414	414	T_{OUT} [kgf·m]		
41700	41700	41700	41700	41700	41700	41700	41700	41700	41700	41700	41700	Prof [N]		
4250	4250	4250	4250	4250	4250	4250	4250	4250	4250	4250	4250	Prof [kgf]		
-	-	-	-	-	-	-	-	-	-	-	-	P_i [kW]	CHH C-75 CHF C-80 CVW C-87	6180DB
-	-	-	-	-	-	-	-	-	-	-	-	T_{OUT} [N·m]		
-	-	-	-	-	-	-	-	-	-	-	-	T_{OUT} [kgf·m]		
-	-	-	-	-	-	-	-	-	-	-	-	Prof [N]		
-	-	-	-	-	-	-	-	-	-	-	-	Prof [kgf]		
1.01	0.816	0.750	0.750	0.750	0.401	0.400	0.400	0.400	0.400	0.400	0.400	P_i [kW]	CHH C-74 CHF C-79 CVW C-86	6185DA
5000	5000	5000	5000	5000	5000	5000	5000	5000	5000	5000	5000	T_{OUT} [N·m]		
510	510	510	510	510	510	510	510	510	510	510	510	T_{OUT} [kgf·m]		
41600	41700	41700	41700	41600	41600	41700	41600	41700	41700	41700	41700	Prof [N]		
4240	4250	4250	4250	4240	4240	4250	4240	4250	4250	4250	4250	Prof [kgf]		
1003	1247	1479	1849	2065	2537	3045	3481	4437	5133	6177	7569	Ratio[Z]	Dim. Page	Frame Size
1.74	1.40	1.18	0.946	0.847	0.690	0.575	0.503	0.394	0.341	0.283	0.231	n_2 [r/min]		

Note: 3. Necessary input power for starting is printed in bold face. Do not exceed allowable output torque after startup.

Selection Tables
Ratio 104, 121 - 7569

REDUCERS

Selection Tables 6000 Series Reducer

Double Reduction Ratio 104,121 ~ 7569 Frame Size: 6185DB ~ 6235DB

Input Speed	$n_1 = 1750$ r/min	n_1 : Input Speed [r/min]	T_{out} : Allowable output torque [N·m, kgf·m]
		n_2 : Output Speed [r/min]	Pro: Allowable output shaft radial load [N, kgf]
		P_i : Allowable input power [kW]	*Consult us for Pro of CNF and CHF type.

Frame Size	n_2 [r/min] Ratio[Z]	16.8	14.5	12.2	10.6	8.97	7.58	6.41	5.49	4.64	3.70	3.13	2.70	2.39	2.08
		104	121	143	165	195	231	273	319	377	473	559	649	731	841
6185DB	P_i [kW]	9.60	8.09	6.98	6.07	5.14	4.41	3.73	3.19	2.70	-	-	-	-	-
	T_{out} [N·m]	4900	4810	4900	4920	4920	5000	5000	5000	5000	-	-	-	-	-
	T_{out} [kgf·m]	500	490	500	502	502	510	510	510	510	-	-	-	-	-
	Pro[N]	37300	40000	41700	41700	41700	41700	41700	41700	41700	-	-	-	-	-
	Pro[kgf]	3800	4070	4250	4250	4250	4250	4250	4250	4250	-	-	-	-	-
6190DA	P_i [kW]	-	-	6.25	6.25	6.25	5.62	4.76	4.07	3.45	2.75	2.32	2.00	1.78	1.54
	T_{out} [N·m]	-	-	4390	5060	5980	6380	6380	6380	6380	6380	6380	6380	6380	6380
	T_{out} [kgf·m]	-	-	447	516	610	650	650	650	650	650	650	650	650	650
	Pro[N]	-	-	59000	59000	59000	59000	59000	59000	59000	59000	59000	58600	59000	59000
	Pro[kgf]	-	-	6010	6010	6010	6010	6010	6010	6010	6010	6010	5970	6010	6010
6190DB	P_i [kW]	11.9	10.7	9.08	7.87	6.66	5.62	-	-	-	-	-	-	-	-
	T_{out} [N·m]	6090	6380	6380	6380	6380	6380	-	-	-	-	-	-	-	-
	T_{out} [kgf·m]	621	650	650	650	650	650	-	-	-	-	-	-	-	-
	Pro[N]	52400	55900	58400	58900	58900	59000	-	-	-	-	-	-	-	-
	Pro[kgf]	5340	5700	5950	6000	6000	6010	-	-	-	-	-	-	-	-
6195DA	P_i [kW]	-	-	-	-	6.25	6.25	5.94	5.08	4.30	3.43	2.90	2.50	2.22	1.93
	T_{out} [N·m]	-	-	-	-	5980	7090	7960	7960	7960	7960	7960	7960	7960	7960
	T_{out} [kgf·m]	-	-	-	-	610	723	811	811	811	811	811	811	811	811
	Pro[N]	-	-	-	-	59000	59000	59000	59000	59000	59000	59000	58100	59000	59000
	Pro[kgf]	-	-	-	-	6010	6010	6010	6010	6010	6010	6010	5930	6010	6010
6195DB	P_i [kW]	11.9	11.9	10.9	9.76	8.26	7.02	5.94	-	-	-	-	-	-	-
	T_{out} [N·m]	6090	7090	7630	7910	7910	7960	7960	-	-	-	-	-	-	-
	T_{out} [kgf·m]	621	723	778	806	806	811	811	-	-	-	-	-	-	-
	Pro[N]	52400	55700	57900	58300	58300	59000	59000	-	-	-	-	-	-	-
	Pro[kgf]	5340	5680	5900	5940	5940	6010	6010	-	-	-	-	-	-	-
6205DA	P_i [kW]	-	-	-	-	-	-	5.86	4.84	4.34	3.35	3.00	2.44	2.52	2.23
	T_{out} [N·m]	-	-	-	-	-	-	7860	7590	8030	7780	8230	7790	9060	9230
	T_{out} [kgf·m]	-	-	-	-	-	-	801	773	819	793	839	794	923	941
	Pro[N]	-	-	-	-	-	-	84100	84100	84100	84100	84100	84100	84100	84100
	Pro[kgf]	-	-	-	-	-	-	8570	8570	8570	8570	8570	8570	8570	8570
6205DB	P_i [kW]	-	11.9	-	11.4	9.68	8.17	6.92	5.89	4.99	4.00	3.39	2.92	2.59	-
	T_{out} [N·m]	-	7090	-	9270	9270	9270	9270	9230	9230	9300	9300	9300	9300	-
	T_{out} [kgf·m]	-	723	-	945	945	945	945	941	941	948	948	948	948	-
	Pro[N]	-	84100	-	84100	84100	84100	84100	84100	84100	84100	84100	84100	84100	-
	Pro[kgf]	-	8570	-	8570	8570	8570	8570	8570	8570	8570	8570	8570	8570	-
6215DA	P_i [kW]	-	-	-	11.9	11.9	11.0	9.32	8.07	6.83	5.45	4.61	3.97	3.52	3.06
	T_{out} [N·m]	-	-	-	9670	11400	12500	12500	12700	12700	12700	12700	12700	12700	12700
	T_{out} [kgf·m]	-	-	-	985	1160	1270	1270	1290	1290	1290	1290	1290	1290	1290
	Pro[N]	-	-	-	104000	104000	104000	104000	104000	104000	104000	104000	104000	104000	104000
	Pro[kgf]	-	-	-	10600	10600	10600	10600	10600	10600	10600	10600	10600	10600	10600
6215DB	P_i [kW]	-	19.1	-	15.0	12.7	-	-	-	-	-	-	-	-	-
	T_{out} [N·m]	-	11400	-	12200	12200	-	-	-	-	-	-	-	-	-
	T_{out} [kgf·m]	-	1160	-	1240	1240	-	-	-	-	-	-	-	-	-
	Pro[N]	-	101000	-	104000	104000	-	-	-	-	-	-	-	-	-
	Pro[kgf]	-	10300	-	10600	10600	-	-	-	-	-	-	-	-	-
6225DA	P_i [kW]	-	-	-	-	11.9	11.9	11.0	9.60	8.12	6.89	5.83	4.98	4.46	3.64
	T_{out} [N·m]	-	-	-	-	11400	13500	14800	15000	15000	16000	16000	15900	16000	15000
	T_{out} [kgf·m]	-	-	-	-	1160	1380	1510	1530	1530	1630	1630	1620	1630	1530
	Pro[N]	-	-	-	-	122000	130000	137000	142000	145000	145000	145000	145000	145000	145000
	Pro[kgf]	-	-	-	-	12500	13200	13900	14500	14800	14800	14800	14800	14800	14800
6225DB	P_i [kW]	-	22.6	-	17.9	15.1	13.0	-	-	-	-	-	-	-	-
	T_{out} [N·m]	-	13500	-	14500	14500	14800	-	-	-	-	-	-	-	-
	T_{out} [kgf·m]	-	1370	-	1480	1480	1510	-	-	-	-	-	-	-	-
	Pro[N]	-	106000	-	115000	122000	130000	-	-	-	-	-	-	-	-
	Pro[kgf]	-	10800	-	11800	12400	13200	-	-	-	-	-	-	-	-
6235DA	P_i [kW]	-	25.4	-	24.2	20.5	16.7	14.1	12.1	10.2	8.82	7.47	6.43	5.71	4.58
	T_{out} [N·m]	-	15100	-	19600	19600	18900	18900	18900	18900	20500	20500	20500	20500	18900
	T_{out} [kgf·m]	-	1540	-	2000	2000	1930	1930	1930	1930	2090	2090	2090	2090	1930
	Pro[N]	-	133000	-	143000	150000	162000	170000	177000	179000	179000	179000	179000	179000	179000
	Pro[kgf]	-	13600	-	14500	15300	16500	17300	18100	18200	18200	18200	18200	18200	18200
6235DB	P_i [kW]	-	31.5	-	24.2	-	-	-	-	-	-	-	-	-	-
	T_{out} [N·m]	-	18700	-	19600	-	-	-	-	-	-	-	-	-	-
	T_{out} [kgf·m]	-	1910	-	2000	-	-	-	-	-	-	-	-	-	-
	Pro[N]	-	133000	-	143000	-	-	-	-	-	-	-	-	-	-
	Pro[kgf]	-	13500	-	14500	-	-	-	-	-	-	-	-	-	-
Frame Size	Ratio[Z]	104	121	143	165	195	231	273	319	377	473	559	649	731	841
	n_2 [r/min]	16.8	14.5	12.2	10.6	8.97	7.58	6.41	5.49	4.64	3.70	3.13	2.70	2.39	2.08

Note: 1. Allowable radial load Pro is the value at the midpoint of the output shaft. Refer to pages F-11~12 when radial load is off the midpoint of output shaft and for checking thrust load.

2. Refer to pages F-15~16 for allowable radial load for input shaft.

Selection Tables 6000 Series Reducer

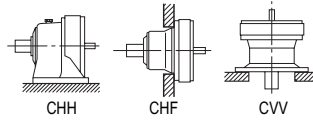

Input Speed $n_1 = 1750$ r/min

1.74	1.40	1.18	0.946	0.847	0.690	0.575	0.503	0.394	0.341	0.283	0.231	n_2 [r/min]	Dim. Page	Frame Size
1003	1247	1479	1849	2065	2537	3045	3481	4437	5133	6177	7569	Ratio[Z]		
-	-	-	-	-	-	-	-	-	-	-	-	P_i [kW]	CHH C-75 CHF C-80 CVW C-87	6185DB
-	-	-	-	-	-	-	-	-	-	-	-	T_{OUT} [N·m]		
-	-	-	-	-	-	-	-	-	-	-	-	T_{OUT} [kgf·m]		
-	-	-	-	-	-	-	-	-	-	-	-	Prof[N]		
-	-	-	-	-	-	-	-	-	-	-	-	Prof[kgf]		
1.30	1.04	0.878	0.750	0.750	0.750	0.750	0.750	0.750	0.750	0.750	0.750	P_i [kW]	CHH C-75 CHF C-80 CVW C-87	6190DA
6380	6380	6380	6380	6380	6380	6380	6380	6380	6380	6380	6380	T_{OUT} [N·m]		
650	650	650	650	650	650	650	650	650	650	650	650	T_{OUT} [kgf·m]		
58600	59000	58900	59000	58600	58600	58900	58600	58900	58900	58900	58900	Prof[N]		
5970	6010	6000	6010	5970	5970	6000	5970	6000	6000	6000	6000	Prof[kgf]		
-	-	-	-	-	-	-	-	-	-	-	-	P_i [kW]	CHH C-75 CHF C-80 CVW C-87	6190DB
-	-	-	-	-	-	-	-	-	-	-	-	T_{OUT} [N·m]		
-	-	-	-	-	-	-	-	-	-	-	-	T_{OUT} [kgf·m]		
-	-	-	-	-	-	-	-	-	-	-	-	Prof[N]		
-	-	-	-	-	-	-	-	-	-	-	-	Prof[kgf]		
1.62	1.30	1.10	0.877	0.785	0.750	0.750	0.750	0.750	0.750	0.750	0.750	P_i [kW]	CHH C-75 CHF C-80 CVW C-87	6195DA
7960	7960	7960	7960	7960	7960	7960	7960	7960	7960	7960	7960	T_{OUT} [N·m]		
811	811	811	811	811	811	811	811	811	811	811	811	T_{OUT} [kgf·m]		
58100	59000	58400	59000	58100	58100	58400	58100	58400	58400	58400	58400	Prof[N]		
5930	6010	5950	6010	5930	5930	5950	5930	5950	5950	5950	5950	Prof[kgf]		
-	-	-	-	-	-	-	-	-	-	-	-	P_i [kW]	CHH C-75 CHF C-80 CVW C-87	6195DB
-	-	-	-	-	-	-	-	-	-	-	-	T_{OUT} [N·m]		
-	-	-	-	-	-	-	-	-	-	-	-	T_{OUT} [kgf·m]		
-	-	-	-	-	-	-	-	-	-	-	-	Prof[N]		
-	-	-	-	-	-	-	-	-	-	-	-	Prof[kgf]		
2.20	2.20	1.50	1.50	1.50	0.750	0.750	0.750	0.750	0.750	0.750	0.750	P_i [kW]	CHH C-75 CHF C-80 CVW C-87	6205DA
9060	9300	8360	9300	9300	9300	8760	9300	8760	9300	8760	8760	T_{OUT} [N·m]		
923	948	853	948	948	948	893	948	893	948	893	893	T_{OUT} [kgf·m]		
84100	84100	84100	84100	84100	84100	84100	84100	84100	84100	84100	84100	Prof[N]		
8570	8570	8570	8570	8570	8570	8570	8570	8570	8570	8570	8570	Prof[kgf]		
2.20	-	1.50	-	-	-	-	-	-	-	-	-	P_i [kW]	CHH C-75 CHF C-80 CVW C-87	6205DB
9300	-	8760	-	-	-	-	-	-	-	-	-	T_{OUT} [N·m]		
948	-	893	-	-	-	-	-	-	-	-	-	T_{OUT} [kgf·m]		
84100	-	84100	-	-	-	-	-	-	-	-	-	Prof[N]		
8570	-	8570	-	-	-	-	-	-	-	-	-	Prof[kgf]		
2.57	2.20	1.55	1.50	1.50	1.50	1.50	1.50	1.50	1.50	1.50	1.50	P_i [kW]	CHH C-75 CHF C-80 CVW C-87	6215DA
12700	12700	11300	12700	12700	12700	11300	12700	11300	12700	11300	11300	T_{OUT} [N·m]		
1290	1290	1150	1290	1290	1290	1150	1290	1150	1290	1150	1150	T_{OUT} [kgf·m]		
104000	104000	104000	104000	104000	104000	104000	104000	104000	104000	104000	104000	Prof[N]		
10600	10600	10600	10600	10600	10600	10600	10600	10600	10600	10600	10600	Prof[kgf]		
-	-	-	-	-	-	-	-	-	-	-	-	P_i [kW]	CHH C-75 CHF C-80 CVW C-87	6215DB
-	-	-	-	-	-	-	-	-	-	-	-	T_{OUT} [N·m]		
-	-	-	-	-	-	-	-	-	-	-	-	T_{OUT} [kgf·m]		
-	-	-	-	-	-	-	-	-	-	-	-	Prof[N]		
-	-	-	-	-	-	-	-	-	-	-	-	Prof[kgf]		
3.22	2.61	2.20	1.76	1.57	1.50	1.50	1.50	1.50	1.50	1.50	1.50	P_i [kW]	CHH C-75 CHF C-80 CVW C-87	6225DA
15900	16000	15100	16000	15900	15900	15100	15900	15100	15900	15100	15100	T_{OUT} [N·m]		
1620	1630	1540	1630	1620	1620	1540	1620	1540	1620	1540	1540	T_{OUT} [kgf·m]		
145000	145000	145000	145000	145000	145000	145000	145000	145000	145000	145000	145000	Prof[N]		
14800	14800	14800	14800	14800	14800	14800	14800	14800	14800	14800	14800	Prof[kgf]		
-	-	-	-	-	-	-	-	-	-	-	-	P_i [kW]	CHH C-75 CHF C-80 CVW C-87	6225DB
-	-	-	-	-	-	-	-	-	-	-	-	T_{OUT} [N·m]		
-	-	-	-	-	-	-	-	-	-	-	-	T_{OUT} [kgf·m]		
-	-	-	-	-	-	-	-	-	-	-	-	Prof[N]		
-	-	-	-	-	-	-	-	-	-	-	-	Prof[kgf]		
4.16	3.35	2.36	2.26	2.20	2.20	2.20	2.20	2.20	2.20	2.20	2.20	P_i [kW]	CHH C-75 CHF C-80 CVW C-87	6235DA
20500	20500	17200	20500	20500	20500	17200	20500	17200	20500	17200	17200	T_{OUT} [N·m]		
2090	2090	1750	2090	2090	2090	1750	2090	1750	2090	1750	1750	T_{OUT} [kgf·m]		
179000	179000	179000	179000	179000	179000	179000	179000	179000	179000	179000	179000	Prof[N]		
18200	18200	18200	18200	18200	18200	18200	18200	18200	18200	18200	18200	Prof[kgf]		
-	-	-	-	-	-	-	-	-	-	-	-	P_i [kW]	CHH C-75 CHF C-80 CVW C-87	6235DB
-	-	-	-	-	-	-	-	-	-	-	-	T_{OUT} [N·m]		
-	-	-	-	-	-	-	-	-	-	-	-	T_{OUT} [kgf·m]		
-	-	-	-	-	-	-	-	-	-	-	-	Prof[N]		
-	-	-	-	-	-	-	-	-	-	-	-	Prof[kgf]		
1003	1247	1479	1849	2065	2537	3045	3481	4437	5133	6177	7569	Ratio[Z]	Dim. Page	Frame Size
1.74	1.40	1.18	0.946	0.847	0.690	0.575	0.503	0.394	0.341	0.283	0.231	n_2 [r/min]		

Note: 3. Necessary input power for starting is printed in bold face. Do not exceed allowable output torque after startup.

REDUCERS
Selection Tables
Ratio 104, 121 - 7569

Selection Tables 6000 Series Reducer

Double Reduction Ratio 104,121 ~ 7569 Frame Size: 6245DA ~ 6275DA

Input Speed	$n_1 = 1750$ r/min	n_1 : Input Speed [r/min]	T_{out} : Allowable output torque [N·m, kgf·m]
		n_2 : Output Speed [r/min]	Pro: Allowable output shaft radial load [N, kgf]
		P_i : Allowable input power [kW]	*Consult us for Pro of CNF and CHF type.

Frame Size	n_2 [r/min]	16.8	14.5	12.2	10.6	8.97	7.58	6.41	5.49	4.64	3.70	3.13	2.70	2.39	2.08
	Ratio[Z]	104	121	143	165	195	231	273	319	377	473	559	649	731	841
6245DA	P_i [kW]	-	-	-	25.4	23.9	22.7	19.2	16.5	13.9	11.1	9.40	8.09	7.19	6.25
	T_{out} [N·m]	-	-	-	20600	22900	25800	25800	25800	25800	25800	25800	25800	25800	25800
	T_{out} [kgf·m]	-	-	-	2100	2330	2630	2630	2630	2630	2630	2630	2630	2630	2630
	Pro[N]	-	-	-	160000	167000	179000	188000	196000	207000	208000	208000	208000	208000	208000
	Pro[kgf]	-	-	-	16300	17100	18200	19200	20000	21100	21200	21200	21200	21200	21200
6245DB	P_i [kW]	-	34.6	-	32.4	27.4	22.7	-	-	-	-	-	-	-	-
	T_{out} [N·m]	-	20500	-	26200	26200	25800	-	-	-	-	-	-	-	-
	T_{out} [kgf·m]	-	2090	-	2680	2680	2630	-	-	-	-	-	-	-	-
	Pro[N]	-	148000	-	158000	167000	179000	-	-	-	-	-	-	-	-
	Pro[kgf]	-	15000	-	16100	17000	18200	-	-	-	-	-	-	-	-
6255DA	P_i [kW]	-	31.8	-	31.8	31.8	27.3	23.1	20.7	17.5	14.9	12.6	10.8	9.61	7.86
	T_{out} [N·m]	-	18900	-	25800	30500	31000	31000	32500	32500	34500	34500	34500	34500	32500
	T_{out} [kgf·m]	-	1930	-	2630	3110	3160	3160	3310	3310	3520	3520	3520	3520	3310
	Pro[N]	-	182000	-	195000	204000	218000	229000	241000	254000	258000	258000	258000	258000	258000
	Pro[kgf]	-	18500	-	19900	20800	22200	23400	24600	25900	26300	26300	26300	26300	26300
6255DB	P_i [kW]	-	46.3	-	38.4	32.5	-	-	-	-	-	-	-	-	-
	T_{out} [N·m]	-	27500	-	31200	31200	-	-	-	-	-	-	-	-	-
	T_{out} [kgf·m]	-	2800	-	3180	3180	-	-	-	-	-	-	-	-	-
	Pro[N]	-	180000	-	194000	204000	-	-	-	-	-	-	-	-	-
	Pro[kgf]	-	18400	-	19800	20800	-	-	-	-	-	-	-	-	-
6265DA	P_i [kW]	-	50.8	-	50.8	45.7	40.5	34.3	29.4	24.8	19.8	16.8	14.4	12.8	11.1
	T_{out} [N·m]	-	30200	-	41100	43700	46000	46000	46000	46000	46000	46000	46000	46000	46000
	T_{out} [kgf·m]	-	3080	-	4190	4460	4690	4690	4690	4690	4690	4690	4690	4690	4690
	Pro[N]	-	221000	-	236000	248000	265000	276000	276000	276000	276000	276000	276000	276000	276000
	Pro[kgf]	-	22500	-	24100	25300	27000	28100	28100	28100	28100	28100	28100	28100	28100
6275DA	P_i [kW]	-	-	-	-	-	-	-	43.5	36.8	29.4	24.8	21.4	19.0	16.5
	T_{out} [N·m]	-	-	-	-	-	-	-	68200	68200	68200	68200	68200	68200	68200
	T_{out} [kgf·m]	-	-	-	-	-	-	-	6950	6950	6950	6950	6950	6950	6950
	Pro[N]	-	-	-	-	-	-	-	248000	248000	248000	248000	248000	248000	248000
	Pro[kgf]	-	-	-	-	-	-	-	25300	25300	25300	25300	25300	25300	25300
Frame Size	Ratio[Z]	104	121	143	165	195	231	273	319	377	473	559	649	731	841
	n_2 [r/min]	16.8	14.5	12.2	10.6	8.97	7.58	6.41	5.49	4.64	3.70	3.13	2.70	2.39	2.08

Selection Tables
Ratio 104,121 ~ 7569
REDUCERS

Note: 1. Allowable radial load Pro is the value at the midpoint of the output shaft. Refer to pages F-11~12 when radial load is off the midpoint of output shaft and for checking thrust load.

2. Refer to pages F-15~16 for allowable radial load for input shaft.

Selection Tables 6000 Series Reducer

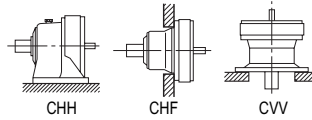

Input Speed	$n_1 = 1750$ r/min
-------------	--------------------

1.74	1.40	1.18	0.946	0.847	0.690	0.575	0.503	0.394	0.341	0.283	0.231	n_2 [r/min]	Dim. Page	Frame Size
1003	1247	1479	1849	2065	2537	3045	3481	4437	5133	6177	7569	Ratio[Z]		
5.24	4.21	3.12	2.84	2.54	2.20	2.20	2.20	2.20	2.20	2.20	2.20	P_i [kW]	CHH C-75	6245DA
25800	25800	22600	25800	25800	25800	22600	25800	22600	25800	22600	22600	T_{OUT} [N•m]	CHF C-80	
2630	2630	2310	2630	2630	2630	2310	2630	2310	2630	2310	2310	T_{OUT} [kgf•m]	CW C-87	
208000	208000	208000	208000	208000	208000	208000	208000	208000	208000	208000	208000	Pro[N]		
21200	21200	21200	21200	21200	21200	21200	21200	21200	21200	21200	21200	Pro[kgf]		
-	-	-	-	-	-	-	-	-	-	-	-	P_i [kW]	CHH C-75	6245DB
-	-	-	-	-	-	-	-	-	-	-	-	T_{OUT} [N•m]	CHF C-80	
-	-	-	-	-	-	-	-	-	-	-	-	T_{OUT} [kgf•m]	CW C-87	
-	-	-	-	-	-	-	-	-	-	-	-	Pro[N]		
-	-	-	-	-	-	-	-	-	-	-	-	Pro[kgf]		
7.00	5.63	4.27	3.80	3.70	3.70	3.70	3.70	3.70	3.70	3.70	3.70	P_i [kW]	CHH C-75	6255DA
34500	34500	31000	34500	34500	34500	31000	34500	31000	34500	31000	31000	T_{OUT} [N•m]	CHF C-80	
3520	3520	3160	3520	3520	3520	3160	3520	3160	3520	3160	3160	T_{OUT} [kgf•m]	CW C-87	
258000	258000	258000	258000	258000	258000	258000	258000	258000	258000	258000	258000	Pro[N]		
26300	26300	26300	26300	26300	26300	26300	26300	26300	26300	26300	26300	Pro[kgf]		
-	-	-	-	-	-	-	-	-	-	-	-	P_i [kW]	CHH C-75	6255DB
-	-	-	-	-	-	-	-	-	-	-	-	T_{OUT} [N•m]	CHF C-80	
-	-	-	-	-	-	-	-	-	-	-	-	T_{OUT} [kgf•m]	CW C-87	
-	-	-	-	-	-	-	-	-	-	-	-	Pro[N]		
-	-	-	-	-	-	-	-	-	-	-	-	Pro[kgf]		
9.34	7.51	6.06	5.50	5.50	5.50	5.50	5.50	5.50	5.50	5.50	5.50	P_i [kW]	CHH C-75	6265DA
46000	46000	44000	46000	46000	46000	44000	46000	44000	46000	44000	44000	T_{OUT} [N•m]	CHF C-80	
4690	4690	4490	4690	4690	4690	4490	4690	4490	4690	4490	4490	T_{OUT} [kgf•m]	CW C-87	
276000	276000	276000	276000	276000	276000	276000	276000	276000	276000	276000	276000	Pro[N]		
28100	28100	28100	28100	28100	28100	28100	28100	28100	28100	28100	28100	Pro[kgf]		
13.8	11.1	9.39	7.51	7.50	7.50	7.50	7.50	7.50	7.50	7.50	7.50	P_i [kW]	CHH C-75	6275DA
68200	68200	68200	68200	68200	68200	68200	68200	68200	68200	68200	68200	T_{OUT} [N•m]	CHF C-80	
6950	6950	6950	6950	6950	6950	6950	6950	6950	6950	6950	6950	T_{OUT} [kgf•m]	CW C-87	
248000	248000	245000	248000	248000	248000	245000	248000	245000	245000	245000	245000	Pro[N]		
25300	25300	25000	25300	25300	25300	25000	25300	25000	25000	25000	25000	Pro[kgf]		
1003	1247	1479	1849	2065	2537	3045	3481	4437	5133	6177	7569	Ratio[Z]	Dim. Page	Frame Size
1.74	1.40	1.18	0.946	0.847	0.690	0.575	0.503	0.394	0.341	.0283	0.231	n_2 [r/min]		

REDUCERS
Selection Tables
Ratio 104, 121 - 7569

Note: 3. Necessary input power for starting is printed in bold face. Do not exceed allowable output torque after startup.

M E M O

REDUCERS

Selection
Tables

C CYCLO® SPEED REDUCERS

3. Dimension Tables

Dimension Tables Speed Reducer (Horizontal Direction, Foot Mount)

CHH - 607□SK to 611□SK

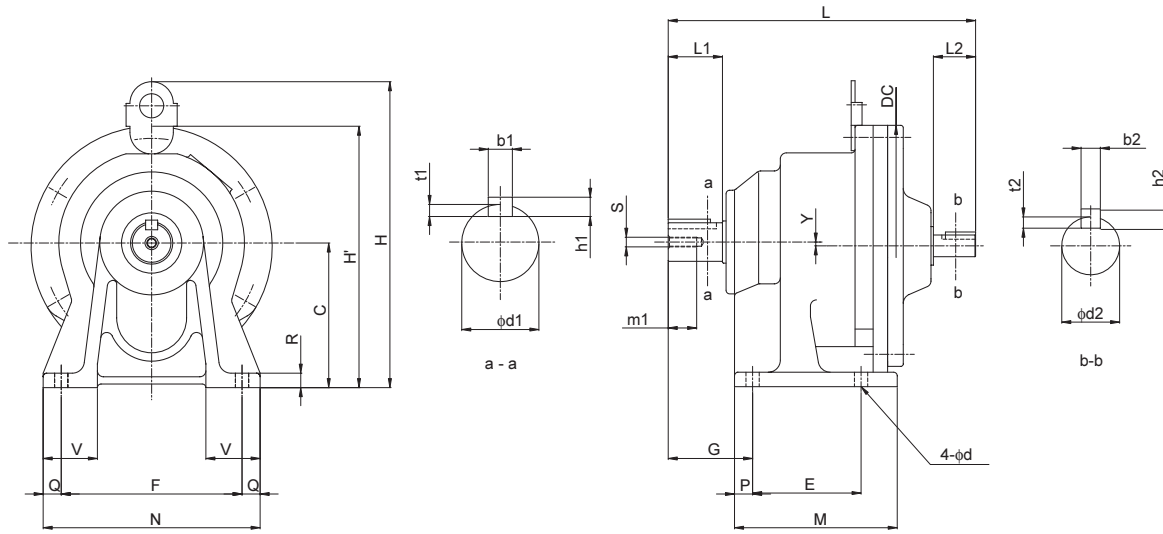

REDUCERS

Dimension Tables
CHH

Frame Size <small>Note 1</small>	L	C	DC	E	F	G	H	H'	M	N	P	Q	R	V	Y	d	W(kg)
607□SK	168	80	134	60	120	47	-	147	84	144	12	12	10	35	0	9	4
608□SK	200	90	150	75	120	52	-	165	99	144	12	12	13	37	0	9	5
609□SK	218	100	150	90	150	60	-	175	135	180	15	15	12	40	0	11	7
610□SK	218	100	162	90	150	60	216	-	135	180	15	15	12	40	0	11	8
611□SK	255	120	204	90	150	70	254	-	135	180	15	15	12	45	3	11	22

Model <small>Note 1</small>	Output Shaft <small>Note 2, 3, 4</small>							Input Shaft <small>Note 2, 3, 4</small>				
	d1	L1	b1	h1	t1	S1	m1	d2	L2	b2	h2	t2
CHH - 607□SK - Ratio	18	30	6	6	3.5	M6	16	12	25	4	4	2.5
CHH - 608□SK - Ratio	22	35	6	6	3.5	M6	16	15	25	5	5	3
CHH - 609□SK - Ratio	28	35	8	7	4	M8	20	15	25	5	5	3
CHH - 610□SK - Ratio	28	35	8	7	4	M8	20	15	25	5	5	3
CHH - 611□SK - Ratio	32	45	10	8	5	M8	20	18	35	6	6	3.5

Note: 1. □ indicates 0 or 5, expressing combination with reduction ratio. Refer to the Selection Table for details.
 2. Dimension of shaft end diameter: Dimension tolerance conforms to JIS B 0401-1976 "h6."
 3. Dimension of shaft end key: Dimension tolerance conforms to JIS B 1301-1996 "Parallel Key."

Dimension Tables Speed Reducer (Universal Direction, Foot Mount)

CNH - 606□ to 612□

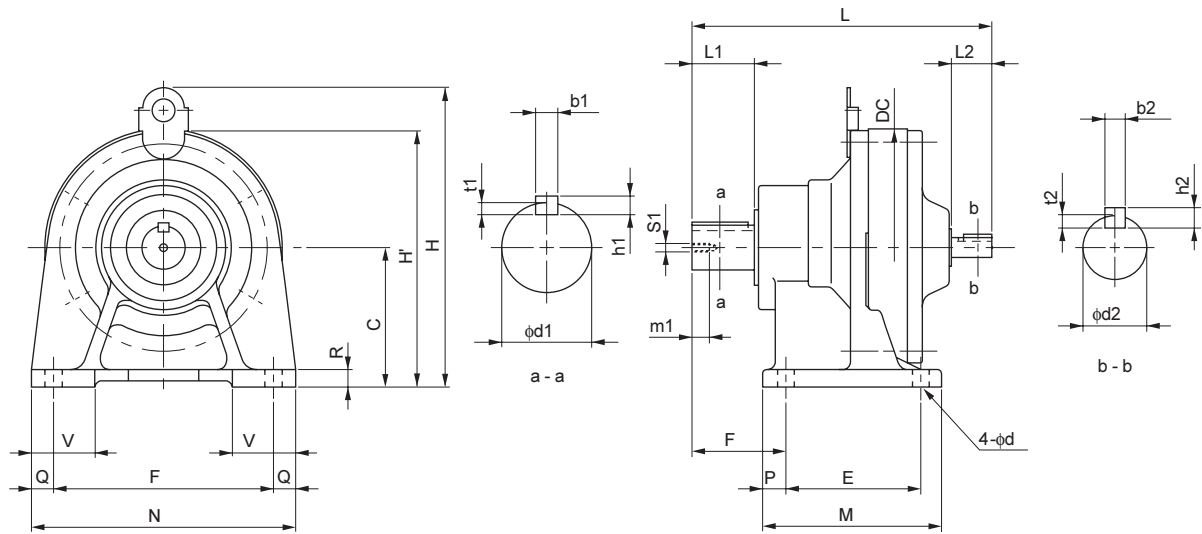

Frame Size <small>Note 1</small>	L	C	DC	E	F	G	H	H'	M	N	P	Q	R	V	d	W(kg)
606□	145	80	110	60	120	41	-	135	84	144	12	12	10	35	9	2.5
607□	151	80	110	60	120	47	-	135	84	144	12	12	10	35	9	2.5
608□	179	90	134	75	120	52	-	157	99	144	12	12	13	37	9	8
609□	202	100	150	90	150	60	-	175	135	180	15	15	12	40	11	11
<small>Note 5</small> 610□	208	100	150	90	150	60	207	-	135	180	15	15	12	40	11	13
611□	218	120	162	90	150	70	236	-	135	180	15	15	12	45	11	15
<small>Note 5</small> 612□	259	120	204	115	190	82	257	-	155	230	20	20	15	55	14	24

Model <small>Note 1</small>	Output Shaft <small>Note 2, 3, 4</small>							Input Shaft <small>Note 2, 3, 4</small>				
	d1	L1	b1	h1	t1	S1	m1	d2	L2	b2	h2	t2
CNH - 606□ - Ratio	14	25	5	5	3	M5	16	12	25	4	4	2.5
CNH - 607□ - Ratio	18	30	6	6	3.5	M6	16	12	25	4	4	2.5
CNH - 608□ - Ratio	22	35	6	6	3.5	M6	16	12	25	4	4	2.5
CNH - 609□ - Ratio	28	35	8	7	4	M8	20	15	25	5	5	3
<small>Note 5</small> CNH - 610□ - Ratio	28	35	8	7	4	M8	20	15	25	5	5	3
CNH - 611□ - Ratio	32	45	10	8	5	M8	20	15	25	5	5	3
<small>Note 5</small> CNH - 612□ - Ratio	38	55	10	8	5	M8	20	18	35	6	6	3.5

Note: 4. Refer to pages F-28~30 for details on input and output shaft end dimensions.
5. Refer to page C-88 for center height options available.
6. Dimensions in above drawings are subject to change without notice.

Dimension Tables Speed Reducer (Horizontal Direction, Foot Mount)

CHH - 613□ to 6275

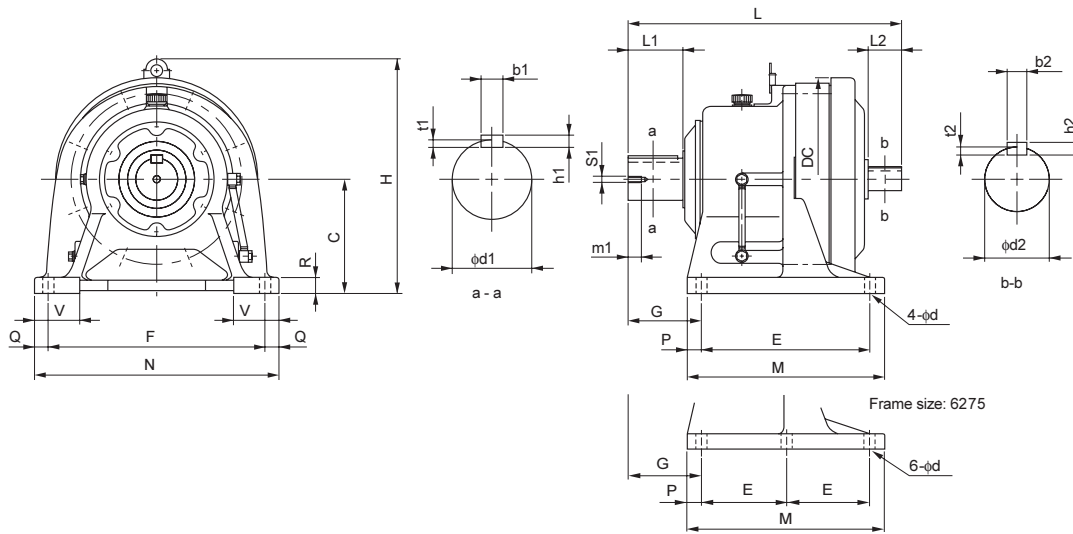

REDUCERS
Dimension Tables
CHH

Frame Size	L	C	DC	E	F	G	H	M	N	P	Q	R	V	d	W(kg)
613□ <small>Note 1</small>	321	150	230	145	290	100	300	195	330	25	20	22	65	18	43
Note 5 614□	341	150	230	145	290	120	300	195	330	25	20	22	65	18	44
Note 5 616□	413	160	318	150	370	139	367	238	410	44	20	25	75	18	84
617□	477	200	362	275	380	125	429	335	430	30	25	30	80	22	125
618□	527	220	390	320	420	145	467	380	470	30	25	30	85	22	163
619□	620	250	451	380	480	170	539	440	530	30	25	35	90	26	240
6205	678	250	471	360	440	215	530	440	530	40	45	35	100	26	255
6215	708	265	507	395	480	210	575	475	580	40	50	40	110	26	336
6225	752	280	549	420	540	230	610	520	620	50	40	40	115	33	409
6235	839	300	591	460	580	260	667	560	670	50	45	45	120	33	503
6245	877	335	637	480	630	263	729	580	720	50	45	45	128	39	614
6255	1040	375	703	520	670	320	815	630	780	55	55	50	140	39	957
6265	1150	400	772	590	770	390	874	700	880	55	55	55	160	45	1190
6275	1462	540	986	420	1050	485	1161	1040	1160	100	55	60	200	45	2460

Model	Ratio	Output Shaft						Input Shaft					
		d1	L1	b1	h1	t1	S1	m1	d2	L2	b2	h2	t2
CHH - 613□	-	50	70	14	9	5.5	M10	18	22	40	6	6	3.5
Note 5 CHH - 614□	-	50	90	14	9	5.5	M10	18	22	40	6	6	3.5
Note 5 CHH - 616□	-	60	90	18	11	7	M10	18	30	45	8	7	4
CHH - 617□	-	70	90	20	12	7.5	M12	24	35	55	10	8	5
CHH - 618□	-	80	110	22	14	9	M12	24	40	65	12	8	5
CHH - 619□	-	95	135	25	14	9	M20	34	45	70	14	9	5.5
CHH - 6205	-	100	165	28	16	10	M20	34	45	82	14	9	5.5
CHH - 6215	-	110	165	28	16	10	M20	34	50	82	14	9	5.5
CHH - 6225	-	120	165	32	18	11	M20	34	55	82	16	10	6
CHH - 6235	-	130	200	32	18	11	M24	41	60	105	18	11	7
CHH - 6245	-	140	200	36	20	12	M24	41	65	105	18	11	7
CHH - 6255	-	160	240	40	22	13	M30	49	80	130	22	14	9
CHH - 6265	-	170	300	40	22	13	M30	49	80	130	22	14	9
CHH - 6275	-	180	330	45	25	15	M30	52	90	150	25	14	9

Note: 1. □ indicates 0 or 5, expressing combination with reduction ratio. Refer to the Selection Table for details.
 2. Dimension of shaft end diameter: Dimension tolerance conforms to JIS B 0401-1976 "h6."
 3. Dimension of shaft end key: Dimension tolerance conforms to JIS B 1301-1996 "Parallel Key."

Dimension Tables Speed Reducer (Universal Direction, Foot Mount)

CNH - 606□DA to 612□DB

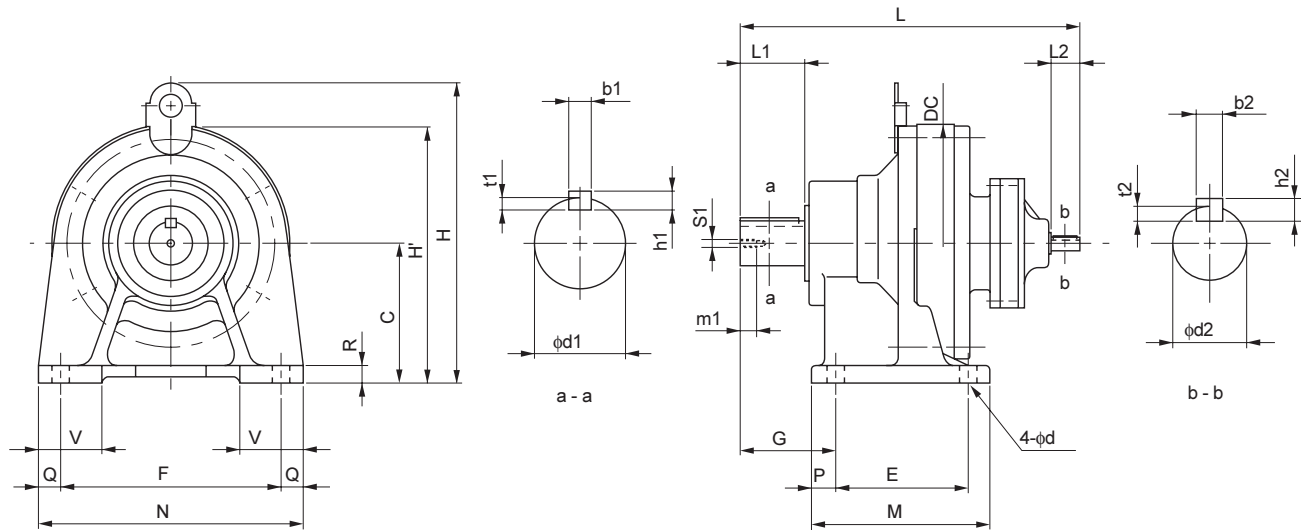

Frame Size <small>Note 1</small>	L	C	DC	E	F	G	H	H'	M	N	P	Q	R	V	d	W(kg)
606□DA	178	80	110	60	120	41	-	135	84	144	12	12	10	35	9	4.0
607□DA	184	80	110	60	120	47	-	135	84	144	12	12	10	35	9	4.5
609□DA	243	100	150	90	150	60	-	175	135	180	15	15	12	40	11	12
610□DA	257	100	150	90	150	60	207	-	135	180	15	15	12	40	11	15
612□DA	293	120	204	115	190	82	257	-	155	230	20	20	15	55	14	26
612□DB	312	120	204	115	190	82	257	-	155	230	20	20	15	55	14	29

Model <small>Note 1</small>	Output Shaft <small>Note 2, 3, 4</small>							Input Shaft <small>Note 2, 3, 4</small>				
	d1	L1	b1	h1	t1	S1	m1	d2	L2	b2	h2	t2
CNH - 606□DA - Ratio	14	25	5	5	3	M5	16	12	25	4	4	2.5
CNH - 607□DA - Ratio	18	30	6	6	3.5	M6	16	12	25	4	4	2.5
CNH - 609□DA - Ratio	28	35	8	7	4	M8	20	12	25	4	4	2.5
CNH - 610□DA - Ratio	28	35	8	7	4	M8	20	12	25	4	4	2.5
CNH - 612□DA - Ratio	38	55	10	8	5	M8	20	12	25	4	4	2.5
CNH - 612□DB - Ratio	38	55	10	8	5	M8	20	15	25	5	5	3

Note: 4. Refer to pages F-28~30 for details on input and output shaft end dimensions.
5. Refer to page C-88 for center height options available.
6. Dimensions in above drawings are subject to change without notice.

Dimension Tables Speed Reducer (Horizontal Direction, Foot Mount)

CHH - 613□DA to 618□DA

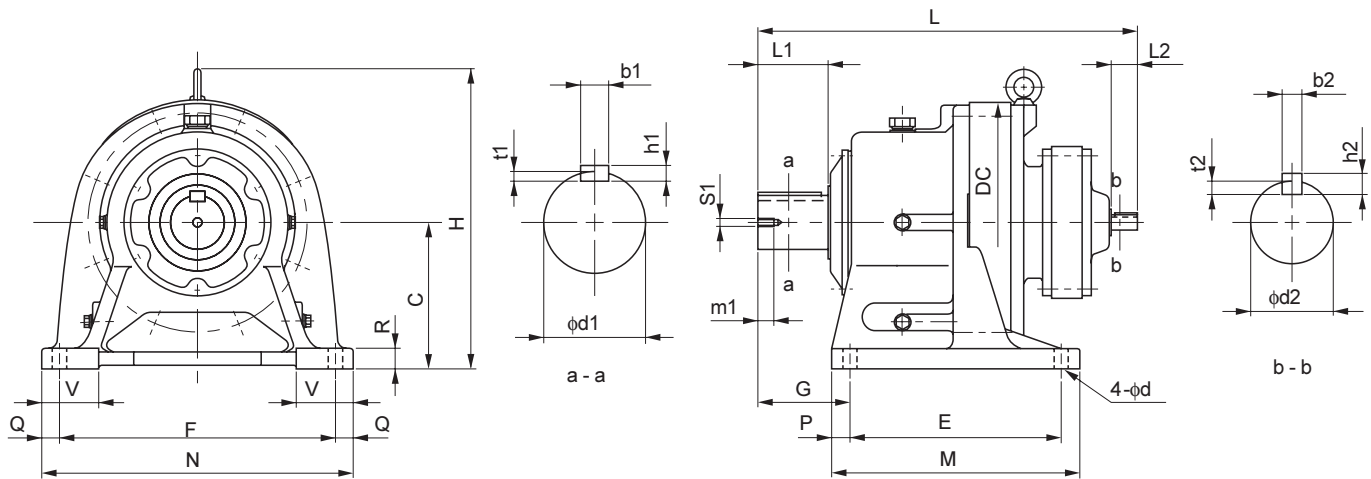

REDUCERS

Dimension Tables
CHH

Frame Size	L	C	DC	E	F	G	H	M	N	P	Q	R	V	d	W(kg)
613□DA	347	150	230	145	290	100	300	195	330	25	20	22	65	18	41
613□DB	363	150	230	145	290	100	300	195	330	25	20	22	65	18	45
613□DC	369	150	230	145	290	100	300	195	330	25	20	22	65	18	46
614□DA	367	150	230	145	290	120	300	195	330	25	20	22	65	18	41
614□DB	383	150	230	145	290	120	300	195	330	25	20	22	65	18	45
614□DC	389	150	230	145	290	120	300	195	330	25	20	22	65	18	46
616□DA	433	160	300	150	370	139	349	238	410	44	20	25	75	18	85
616□DB	439	160	300	150	370	139	349	238	410	44	20	25	75	18	87
617□DA	478	200	340	275	380	125	416	335	430	30	25	30	80	22	121
617□DB	484	200	340	275	380	125	416	335	430	30	25	30	80	22	123
618□DA	526	220	370	320	420	145	451	380	470	30	25	30	85	22	165

Model	Ratio	Output Shaft							Input Shaft				
		d1	L1	b1	h1	t1	S1	m1	d2	L2	b2	h2	t2
CHH - 613□DA	Ratio	50	70	14	9	5.5	M10	18	12	25	4	4	2.5
CHH - 613□DB	Ratio	50	70	14	9	5.5	M10	18	15	25	5	5	3
CHH - 613□DC	Ratio	50	70	14	9	5.5	M10	18	15	25	5	5	3
CHH - 614□DA	Ratio	50	90	14	9	5.5	M10	18	12	25	4	4	2.5
CHH - 614□DB	Ratio	50	90	14	9	5.5	M10	18	15	25	5	5	3
CHH - 614□DC	Ratio	50	90	14	9	5.5	M10	18	15	25	5	5	3
CHH - 616□DA	Ratio	60	90	18	11	7	M10	18	15	25	5	5	3
CHH - 616□DB	Ratio	60	90	18	11	7	M10	18	15	25	5	5	3
CHH - 617□DA	Ratio	70	90	20	12	7.5	M12	24	15	25	5	5	3
CHH - 617□DB	Ratio	70	90	20	12	7.5	M12	24	15	25	5	5	3
CHH - 618□DA	Ratio	80	110	22	14	9	M12	24	15	25	5	5	3

Note: 1. □ indicates 0 or 5, expressing combination with reduction ratio. Refer to the Selection Table for details.
 2. Dimension of shaft end diameter: Dimension tolerance conforms to JIS B 0401-1976 "h6."
 3. Dimension of shaft end key: Dimension tolerance conforms to JIS B 1301-1996 "Parallel Key."

Dimension Tables Speed Reducer (Horizontal Direction, Foot Mount)

CHH - 616□DC to 6275DA

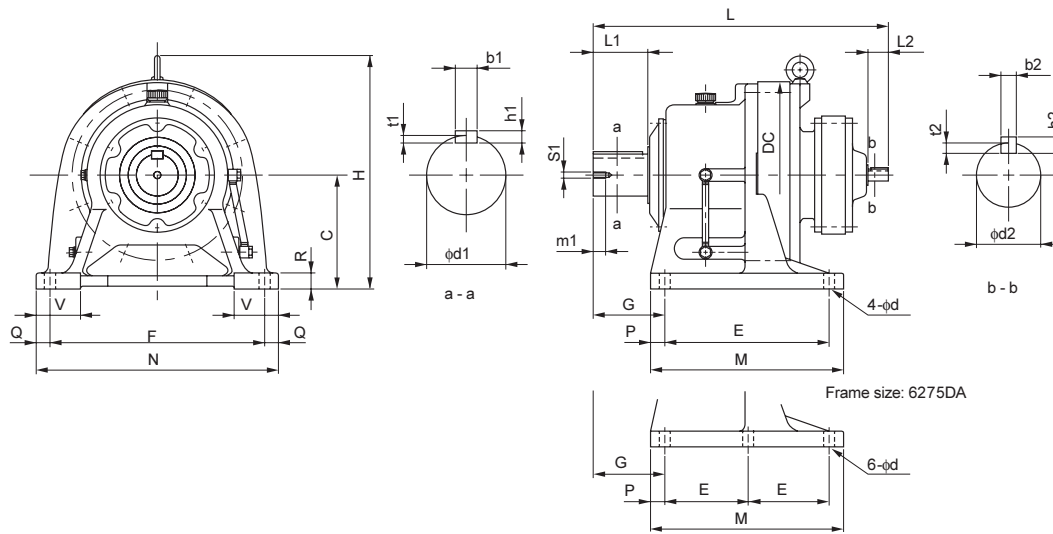

Frame Size	L	C	DC	E	F	G	H	M	N	P	Q	R	V	d	W(kg)
616□DC	462	160	300	150	370	139	349	238	410	44	20	25	75	18	94
617□DC	509	200	340	275	380	125	416	335	430	30	25	30	80	22	128
618□DB	577	220	370	320	420	145	451	380	470	30	25	30	85	22	183
619□DA	629	250	430	380	480	170	531	440	530	30	25	35	90	26	241
619□DB	653	250	430	380	480	170	531	440	530	30	25	35	90	26	250
6205DA	670	250	448	360	440	215	530	440	530	40	45	35	100	26	260
6205DB	705	250	448	360	440	215	530	440	530	40	45	35	100	26	273
6215DA	731	265	485	395	480	210	575	475	580	40	50	40	110	26	354
6215DB	780	265	485	395	480	210	575	475	580	40	50	40	110	26	376
6225DA	773	280	526	420	540	230	610	520	620	50	40	40	115	33	429
6225DB	860	280	526	420	540	230	610	520	620	50	40	40	115	33	476
6235DA	883	300	562	460	580	260	667	560	670	50	45	45	120	33	548
6235DB	938	300	562	460	580	260	667	560	670	50	45	45	120	33	582
6245DA	921	335	614	480	630	263	729	580	720	50	45	45	128	39	656
6245DB	975	335	614	480	630	263	729	580	720	50	45	45	128	39	686
6255DA	1081	375	670	520	670	320	815	630	780	55	55	50	140	39	1010
6255DB	1133	375	670	520	670	320	815	630	780	55	55	50	140	39	1085
6265DA	1243	400	736	590	770	390	874	700	880	55	55	55	160	45	1340
6275DA	1504	540	950	420	1050	485	1161	1040	1160	100	55	60	200	45	2480

Model	Ratio	Output Shaft							Input Shaft				
		d1	L1	b1	h1	t1	S1	m1	d2	L2	b2	h2	t2
CHH - 616□DC	Ratio	60	90	18	11	7	M10	18	18	35	6	6	3.5
CHH - 617□DC	Ratio	70	90	20	12	7.5	M12	24	18	35	6	6	3.5
CHH - 618□DB	Ratio	80	110	22	14	9	M12	24	22	40	6	6	3.5
CHH - 619□DA	Ratio	95	135	25	14	9	M20	34	18	35	6	6	3.5
CHH - 619□DB	Ratio	95	135	25	14	9	M20	34	22	40	6	6	3.5
CHH - 6205DA	Ratio	100	165	28	16	10	M20	34	18	35	6	6	3.5
CHH - 6205DB	Ratio	100	165	28	16	10	M20	34	22	40	6	6	3.5
CHH - 6215DA	Ratio	110	165	28	16	10	M20	34	22	40	6	6	3.5
CHH - 6215DB	Ratio	110	165	28	16	10	M20	34	30	45	8	7	4
CHH - 6225DA	Ratio	120	165	32	18	11	M20	34	22	40	6	6	3.5
CHH - 6225DB	Ratio	120	165	32	18	11	M20	34	35	55	10	8	5
CHH - 6235DA	Ratio	130	200	32	18	11	M24	41	30	45	8	7	4
CHH - 6235DB	Ratio	130	200	32	18	11	M24	41	40	65	12	8	5
CHH - 6245DA	Ratio	140	200	36	20	12	M24	41	30	45	8	7	4
CHH - 6245DB	Ratio	140	200	36	20	12	M24	41	40	65	12	8	5
CHH - 6255DA	Ratio	160	240	40	22	13	M30	49	35	55	10	8	5
CHH - 6255DB	Ratio	160	240	40	22	13	M30	49	45	70	14	9	5.5
CHH - 6265DA	Ratio	170	300	40	22	13	M30	49	45	70	14	9	5.5
CHH - 6275DA	Ratio	180	330	45	25	15	M30	52	45	70	14	9	5.5

Note: 4. Refer to pages F-28~30 for details on input and output shaft end dimensions.
5. Dimensions in above drawings are subject to change without notice.

Dimension Tables Speed Reducer (Universal Direction, Flange Mount)

CNF - 606□ to 612□

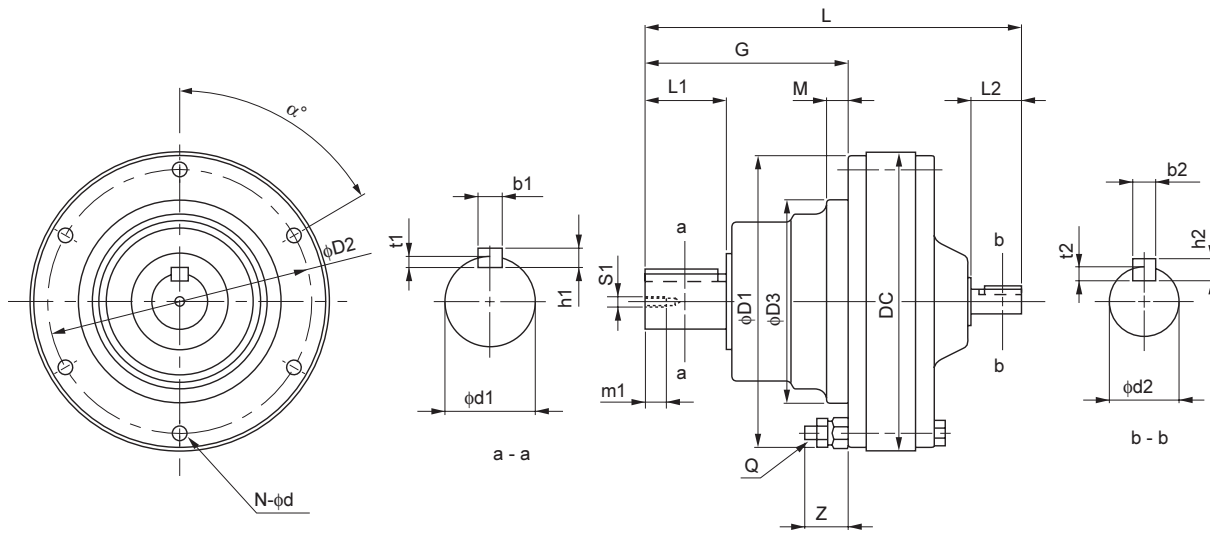

Frame Size <small>Note 1</small>	L	G	D1	D2	D3 <small>Note 4</small>	DC	Q	Z	M	N	d	α°	W(kg)
606□	145	68	110	98	80	110	M6	24	4	6	6.6	60	3
607□	151	74	110	98	80	110	M6	24	4	6	6.6	60	3
608□	178	91	134	118	95	134	M8	27	5	8	9	22.5	8
609□	202	114	150	134	105	150	M8	26	6	8	9	22.5	8.5
610□	208	114	150	134	105	150	M8	27	6	8	9	22.5	9.5
611□	218	118	162	146	115	162	M8	28	6	8	9	22.5	11
612□	259	139	200	180	140	204	M10	30	14	6	11	60	20

Model <small>Note 1</small>	Output Shaft <small>Note 2, 3, 5</small>							Input Shaft <small>Note 2, 3, 5</small>				
	d1	L1	b1	h1	t1	S1	m1	d2	L2	b2	h2	t2
CNF - 606□ - Ratio	14	25	5	5	3	M5	16	12	25	4	4	2.5
CNF - 606□ - Ratio	18	30	6	6	3.5	M6	16	12	25	4	4	2.5
CNF - 608□ - Ratio	22	35	6	6	3.5	M6	16	12	25	4	4	2.5
CNF - 609□ - Ratio	28	35	8	7	4	M8	20	15	25	5	5	3
CNF - 610□ - Ratio	28	35	8	7	4	M8	20	15	25	5	5	3
CNF - 611□ - Ratio	32	45	10	8	5	M8	20	15	25	5	5	3
CNF - 612□ - Ratio	38	55	10	8	5	M8	20	18	35	6	6	3.5

Note: 1. □ indicates 0 or 5, expressing combination with reduction ratio. Refer to the Selection Table for details.
 2. Dimension of shaft end diameter: Dimension tolerance conforms to JIS B 0401-1976 "h6."
 3. Dimension of shaft end key: Dimension tolerance conforms to JIS B 1301-1996 "Parallel Key."

Dimension Tables Speed Reducer (Horizontal Direction, Flange Mount)

CHF - 613□ to 6265

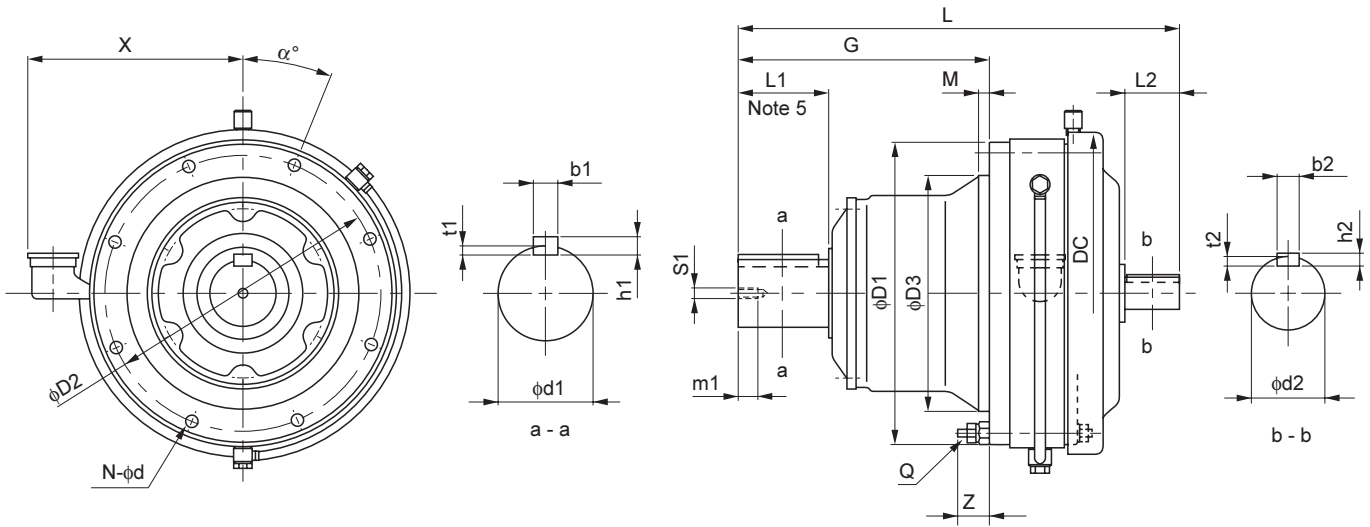

REDUCERS
Dimension Tables
CHF

Frame Size <small>Note 1</small>	L	G	D1	D2	D3 <small>Note 4</small>	DC	Q	Z	M	N	d	α°	x	W(kg)
613□	321	178	226	205	165	230	M10	31	16	6	11	60	208	36
614□	341	198	226	205	165	230	M10	31	16	6	11	60	208	37
616□	413	222	296	270	200	318	M12	35	10	6	14	30	228	66
617□	477	262	330	300	250	362	M12	41	12	8	14	22.5	243	96
618□	527	299	360	330	280	390	M12	38	12	8	14	22.5	258	131
619□	620	365	420	380	320	451	M12	43	10	12	14	15	285	195
6205	678	410	443	405	360	471	M16	57	20	12	18	15	-	213
6215	708	423	480	440	390	507	M18	57	20	12	20.5	15	-	292
6225	752	454	521	475	420	549	M20	65	20	12	22	15	-	347
6235	839	505	557	510	455	591	M20	68	20	12	22	15	-	428
6245	877	529	615	560	500	637	M24	65	25	12	27	15	-	538
6255	1040	616	666	610	540	703	M24	88	30	12	27	15	-	794
6265	1150	712	730	660	570	772	M30	82	40	12	34	15	-	1020

Model <small>Note 1</small>	Output Shaft <small>Note 2, 3, 5</small>								Input Shaft <small>Note 2, 3, 5</small>				
	d1	L1	b1	h1	t1	S1	m1	d2	L2	b2	h2	t2	
CHF - 613□ - Ratio	50	70	14	9	5.5	M10	18	22	40	6	6	3.5	
CHF - 614□ - Ratio	50	90	14	9	5.5	M10	18	22	40	6	6	3.5	
CHF - 616□ - Ratio	60	90	18	11	7	M10	18	30	45	8	7	4	
CHF - 617□ - Ratio	70	90	20	12	7.5	M12	24	35	55	10	8	5	
CHF - 618□ - Ratio	80	110	22	14	9	M12	24	40	65	12	8	5	
CHF - 619□ - Ratio	95	135	25	14	9	M20	34	45	70	14	9	5.5	
CHF - 6205 - Ratio	100	165	28	16	10	M20	34	45	82	14	9	5.5	
CHF - 6215 - Ratio	110	165	28	16	10	M20	34	50	82	14	9	5.5	
CHF - 6225 - Ratio	120	165	32	18	11	M20	34	55	82	16	10	6	
CHF - 6235 - Ratio	130	200	32	18	11	M24	41	60	105	18	11	7	
CHF - 6245 - Ratio	140	200	36	20	12	M24	41	65	105	18	11	7	
CHF - 6255 - Ratio	160	240	40	22	13	M30	49	80	130	22	14	9	
CHF - 6265 - Ratio	170	300	40	22	13	M30	49	80	130	22	14	9	

Note: 4. Pilot diameter ($\phi D3$): Dimension tolerance conforms to JIS B 0401-1976 "g6."
 5. Output shaft length differs from the values in the above table for vertical output shaft down (CVF) type. Refer to pages F-28~30 for details on input and output shaft end dimensions.
 6. Dimensions in above drawings are subject to change without notice.

Dimension Tables Speed Reducer (Universal Direction, Flange Mount)

CNF - 606□DA to 612□DB

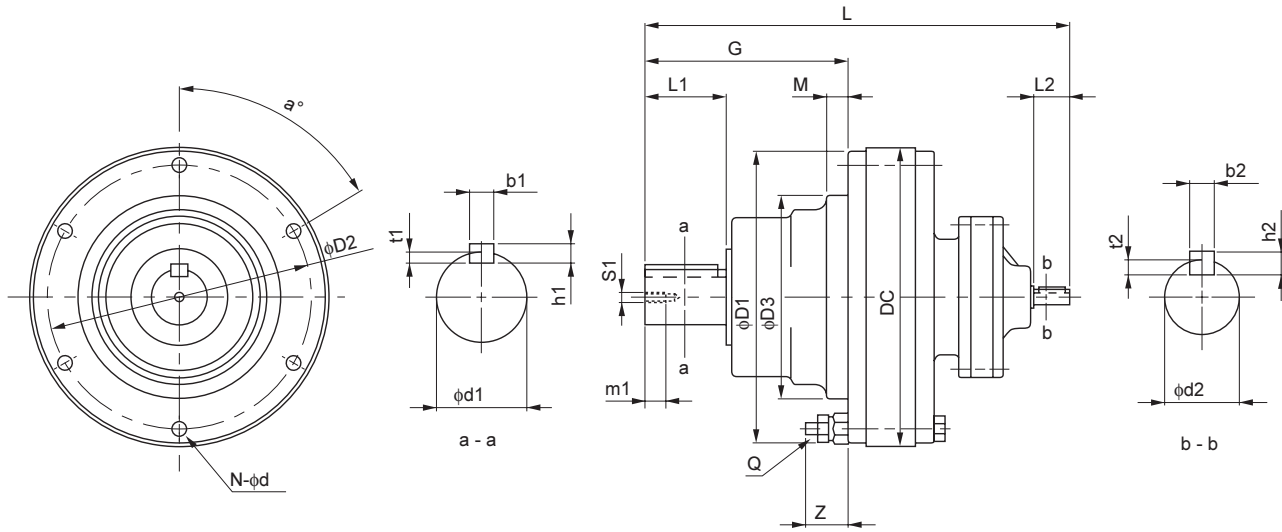

REDUCERS

Dimension Tables
CNF

Frame Size <small>Note 1</small>	L	G	D1	D2	D3	DC	Q	Z	M	N	d	α°	W(kg)
606□DA	178	68	110	98	80	110	M6	26	4	6	6.6	60	4.5
607□DA	184	74	110	98	80	110	M6	26	4	6	6.6	60	4.5
609□DA	243	114	150	134	105	150	M8	26	6	8	9	22.5	10
610□DA	257	114	150	134	105	150	M8	27	6	8	9	22.5	12
612□DA	293	139	200	180	140	204	M10	30	14	6	11	60	22
612□DB	312	139	200	180	140	204	M10	30	14	6	11	60	25

Model <small>Note 1</small>	Output Shaft <small>Note 2, 3, 5</small>							Input Shaft <small>Note 2, 3, 5</small>				
	d1	L1	b1	h1	t1	S1	m1	d2	L2	b2	h2	t2
CNF - 606□DA - Ratio	14	25	5	5	3	M5	16	12	25	4	4	2.5
CNF - 607□DA - Ratio	18	30	6	6	3.5	M6	16	12	25	4	4	2.5
CNF - 609□DA - Ratio	28	35	8	7	4	M8	20	12	25	4	4	2.5
CNF - 610□DA - Ratio	28	35	8	7	4	M8	20	12	25	4	4	2.5
CNF - 612□DA - Ratio	38	55	10	8	5	M8	20	12	25	4	4	2.5
CNF - 612□DB - Ratio	38	55	10	8	5	M8	20	15	25	5	5	3

Note: 1. □ indicates 0 or 5, expressing combination with reduction ratio. Refer to the Selection Table for details.
 2. Dimension of shaft end diameter: Dimension tolerance conforms to JIS B 0401-1976 "h6."
 3. Dimension of shaft end key: Dimension tolerance conforms to JIS B 1301-1996 "Parallel Key."

Dimension Tables Speed Reducer (Universal Direction, Flange Mount)

CHF - 613□DA to 618□DA

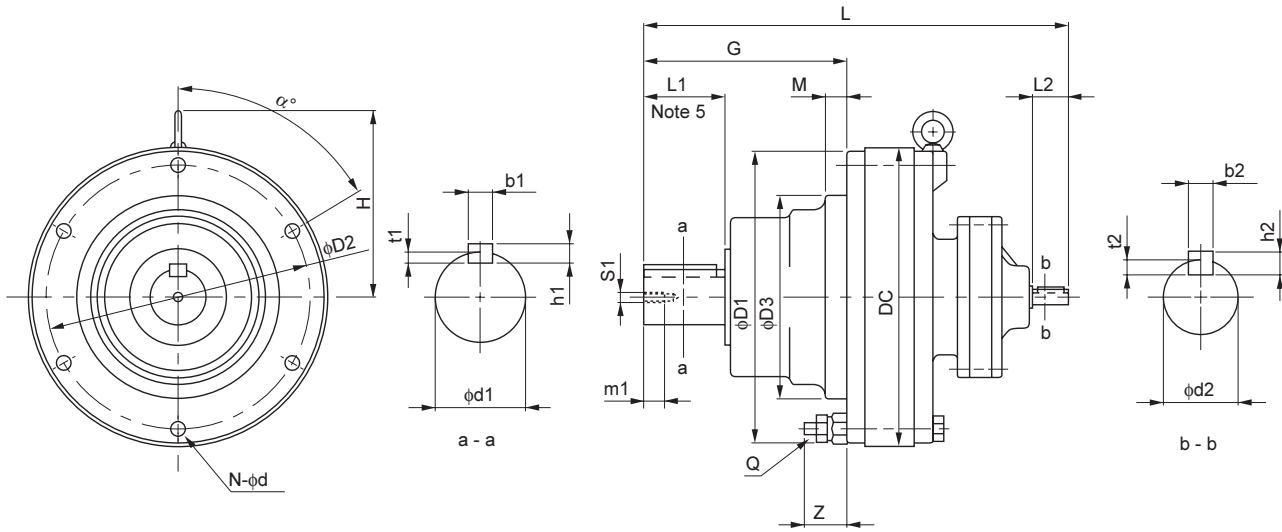

Frame Size <small>Note 1</small>	L	G	D1	D2	D3 <small>Note 4</small>	DC	H	Q	Z	M	N	d	α°	W(kg)
613□DA	347	178	226	205	165	230	150	M10	31	16	6	11	60	36
613□DB	363	178	226	205	165	230	150	M10	31	16	6	11	60	39
613□DC	369	178	226	205	165	230	150	M10	31	16	6	11	60	40
614□DA	367	198	226	205	165	230	150	M10	31	16	6	11	60	36
614□DB	383	198	226	205	165	230	150	M10	31	16	6	11	60	39
614□DC	389	198	226	205	165	230	150	M10	31	16	6	11	60	40
616□DA	433	222	296	270	200	300	189	M12	35	10	6	14	30	68
616□DB	439	222	296	270	200	300	189	M12	35	10	6	14	30	70
617□DA	478	262	330	300	250	340	216	M12	41	12	8	14	22.5	93
617□DB	484	262	330	300	250	340	216	M12	41	12	8	14	22.5	95
618□DA	526	299	360	330	280	370	231	M12	38	12	8	14	22.5	129

Model <small>Note 1</small>	Output Shaft <small>Note 2, 3, 5</small>					Input Shaft <small>Note 2, 3, 5</small>						
	d1	L1	b1	h1	t1	S1	m1	d2	L2	b2	h2	t2
CHF - 613□DA - Ratio	50	70	14	9	5.5	M10	18	12	25	4	4	2.5
CHF - 613□DB - Ratio	50	70	14	9	5.5	M10	18	15	25	5	5	3
CHF - 613□DC - Ratio	50	70	14	9	5.5	M10	18	15	25	5	5	3
CHF - 614□DA - Ratio	50	90	14	9	5.5	M10	18	12	25	4	4	2.5
CHF - 614□DB - Ratio	50	90	14	9	5.5	M10	18	15	25	5	5	3
CHF - 614□DC - Ratio	50	90	14	9	5.5	M10	18	15	25	5	5	3
CHF - 616□DA - Ratio	60	90	18	11	7	M10	18	15	25	5	5	3
CHF - 616□DB - Ratio	60	90	18	11	7	M10	18	15	25	5	5	3
CHF - 617□DA - Ratio	70	90	20	12	7.5	M12	24	15	25	5	5	3
CHF - 617□DB - Ratio	70	90	20	12	7.5	M12	24	15	25	5	5	3
CHF - 618□DA - Ratio	80	110	22	14	9	M12	24	15	25	5	5	3

- Note: 4. Pilot diameter ($\phi D3$): Dimension tolerance conforms to JIS B 0401-1976 "g6."
 5. Output shaft length differs from the values in the above table for vertical output shaft down (CVF) type. Refer to pages F-28~30 for details on input and output shaft end dimensions.
 6. Dimensions in above drawings are subject to change without notice.

Dimension Tables Speed Reducer (Horizontal Direction, Flange Mount)

CHF - 616□DC to 6265DA

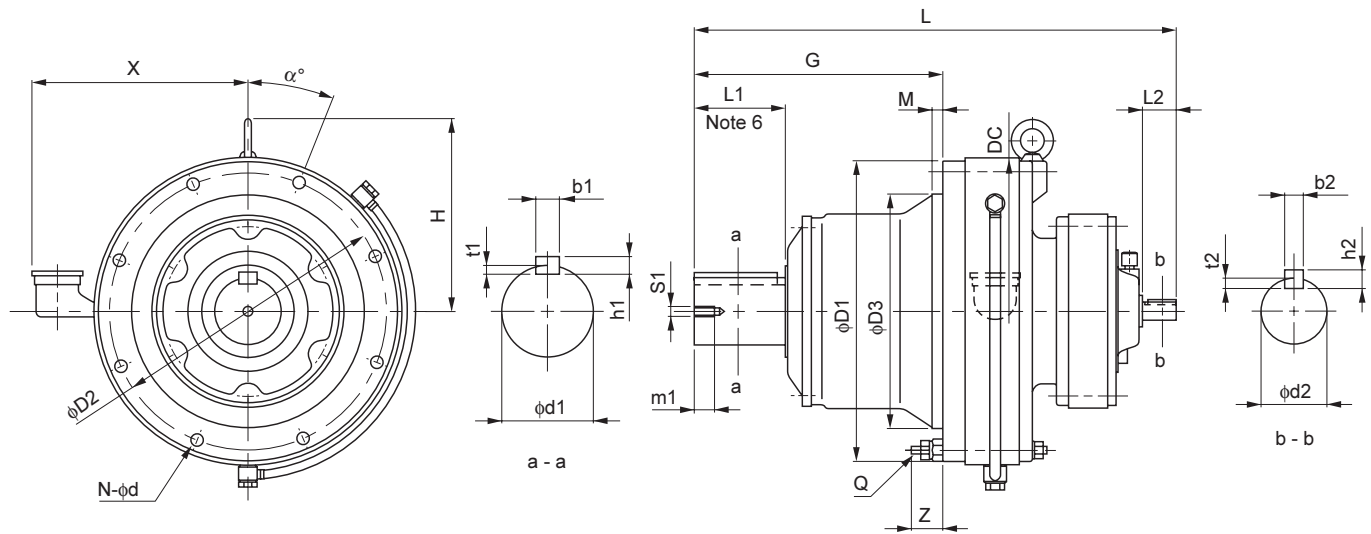

REDUCERS
Dimension Tables
CHF

Frame Size	L	G	D1	D2	D3	DC	H	Q	Z	M	N	d	α°	x	W(kg)
616□DC	462	222	296	270	200	300	189	M12	35	10	6	14	30	228	82
617□DC	509	262	330	300	250	340	216	M12	41	12	8	14	22.5	243	105
618□DB	577	299	360	330	280	370	231	M12	38	12	8	14	22.5	258	146
619□DA	629	365	420	380	320	430	281	M12	43	10	12	14	15	285	201
619□DB	653	365	420	380	320	430	281	M12	43	10	12	14	15	285	205
6205DA	670	410	443	405	360	448	283	M16	57	20	12	18	15	-	217
6205DB	705	410	443	405	360	448	283	M16	57	20	12	18	15	-	227
6215DA	731	423	480	440	390	485	312	M18	57	20	12	20.5	15	-	306
6215DB	780	423	480	440	390	485	312	M18	57	20	12	20.5	15	-	328
6225DA	773	454	521	475	420	526	333	M20	65	20	12	22	15	-	357
6225DB	860	454	521	475	420	526	333	M20	65	20	12	22	15	-	404
6235DA	883	505	557	510	455	562	351	M20	68	20	12	22	15	-	468
6235DB	938	505	557	510	455	562	351	M20	68	20	12	22	15	-	500
6245DA	921	529	615	560	500	614	395	M24	65	25	12	27	15	-	574
6245DB	975	529	615	560	500	614	395	M24	65	25	12	27	15	-	603
6255DA	1081	616	666	610	540	670	386	M24	88	30	12	27	15	-	847
6255DB	1133	616	666	610	540	670	386	M24	88	30	12	27	15	-	926
6265DA	1243	712	730	660	570	736	453	M30	82	40	12	34	15	-	1170

Model	Ratio	Output Shaft						Input Shaft					
		d1	L1	b1	h1	t1	S1	m1	d2	L2	b2	h2	t2
CHF - 616□DC	Ratio	60	90	18	11	7	M10	18	18	35	6	6	3.5
CHF - 617□DC	Ratio	70	90	20	12	7.5	M12	24	18	35	6	6	3.5
CHF - 618□DB	Ratio	80	110	22	14	9	M12	24	22	40	6	6	3.5
CHF - 619□DA	Ratio	95	135	25	14	9	M20	34	18	35	6	6	3.5
CHF - 619□DB	Ratio	95	135	25	14	9	M20	34	22	40	6	6	3.5
CHF - 6205DA	Ratio	100	165	28	16	10	M20	34	18	35	6	6	3.5
CHF - 6205DB	Ratio	100	165	28	16	10	M20	34	22	40	6	6	3.5
CHF - 6215DA	Ratio	110	165	28	16	10	M20	34	22	40	6	6	3.5
CHF - 6215DB	Ratio	110	165	28	16	10	M20	34	30	45	8	7	4
CHF - 6225DA	Ratio	120	165	32	18	11	M20	34	22	40	6	6	3.5
CHF - 6225DB	Ratio	120	165	32	18	11	M20	34	35	55	10	8	5
CHF - 6235DA	Ratio	130	200	32	18	11	M24	41	30	45	8	7	4
CHF - 6235DB	Ratio	130	200	32	18	11	M24	41	40	65	12	8	5
CHF - 6245DA	Ratio	140	200	36	20	12	M24	41	30	45	8	7	4
CHF - 6245DB	Ratio	140	200	36	20	12	M24	41	40	65	12	8	5
CHF - 6255DA	Ratio	160	240	40	22	13	M30	49	35	55	10	8	5
CHF - 6255DB	Ratio	160	240	40	22	13	M30	49	45	70	14	9	5.5
CHF - 6265DA	Ratio	170	300	40	22	13	M30	49	45	70	14	9	5.5

- Note: 1. □ indicates 0 or 5, expressing combination with reduction ratio. Refer to the Selection Table for details.
 2. Dimension of shaft end diameter: Dimension tolerance conforms to JIS B 0401-1976 "h6."
 3. Dimension of shaft end key: Dimension tolerance conforms to JIS B 1301-1996 "Parallel Key."
 4. Pilot diameter ($\phi D3$) of CHF type: Dimension tolerance conforms to JIS B 0401-1976 "g6."
 5. Pilot diameter ($\phi D3$) of CVV type: Dimension tolerance conforms to JIS B 0401-1976 "f8."

Dimension Tables Speed Reducer (Vertical, Slow Speed Shaft Down, V-Flange Mount)

CVV - 607□SK to 611□SK

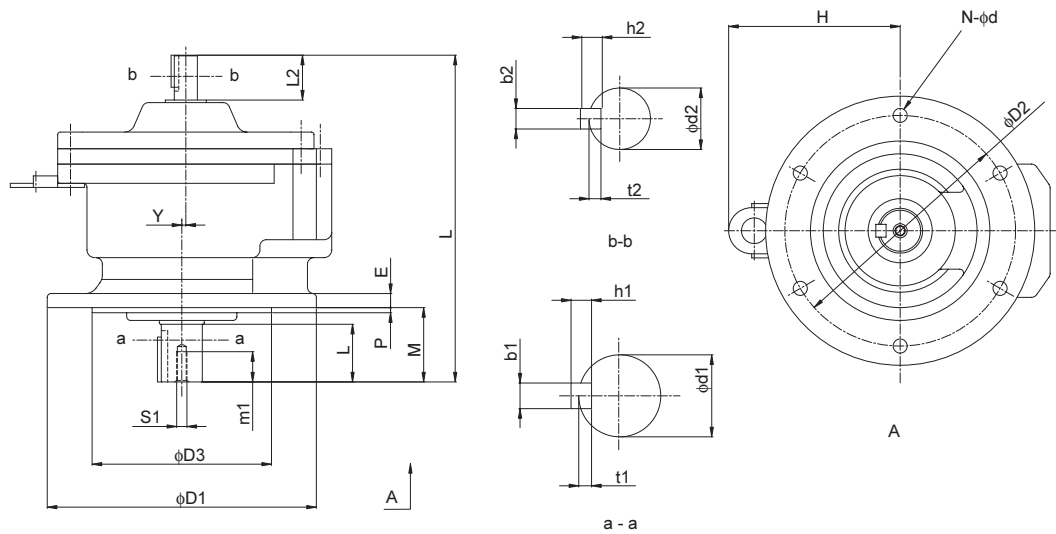

Frame Size <small>Note 1</small>	L	D1	D2	D3 <small>Note 5</small>	H	M	E	P	Y	N	d	W(kg)
607□SK	168	160	134	110	-	42	9	3	0	4	11	6
608□SK	200	160	134	110	-	48	9	3	0	4	11	7
609□SK	218	160	134	110	-	48	9	3	0	4	11	9
610□SK	218	160	134	110	116	48	9	3	0	4	11	10
611□SK	255	210	180	140	134	58	11	4	3	6	11	22

Model <small>Note 1</small>	Output Shaft <small>Note 2, 3</small>							Input Shaft <small>Note 2, 3</small>				
	d1	L1	b1	h1	t1	S1	m1	d2	L2	b2	h2	t2
CVV - 607□SK - Ratio	18	30	6	6	3.5	M6	16	12	25	4	4	2.5
CVV - 608□SK - Ratio	22	35	6	6	3.5	M6	16	15	25	5	5	3
CVV - 609□SK - Ratio	28	35	8	7	4	M8	20	15	25	5	5	3
CVV - 610□SK - Ratio	28	35	8	7	4	M8	20	15	25	5	5	3
CVV - 611□SK - Ratio	32	45	10	8	5	M8	20	18	35	6	6	3.5

Note: 6. Output shaft length differs from the values in the above table for vertical output shaft down (CVF) type. Refer to pages F-28~30 for details on input and output shaft end dimensions.

7. Dimensions in above drawings are subject to change without notice.

Dimension Tables Speed Reducer (Universal Direction, V-Flange Mount)

CNV - 606□ to 612□

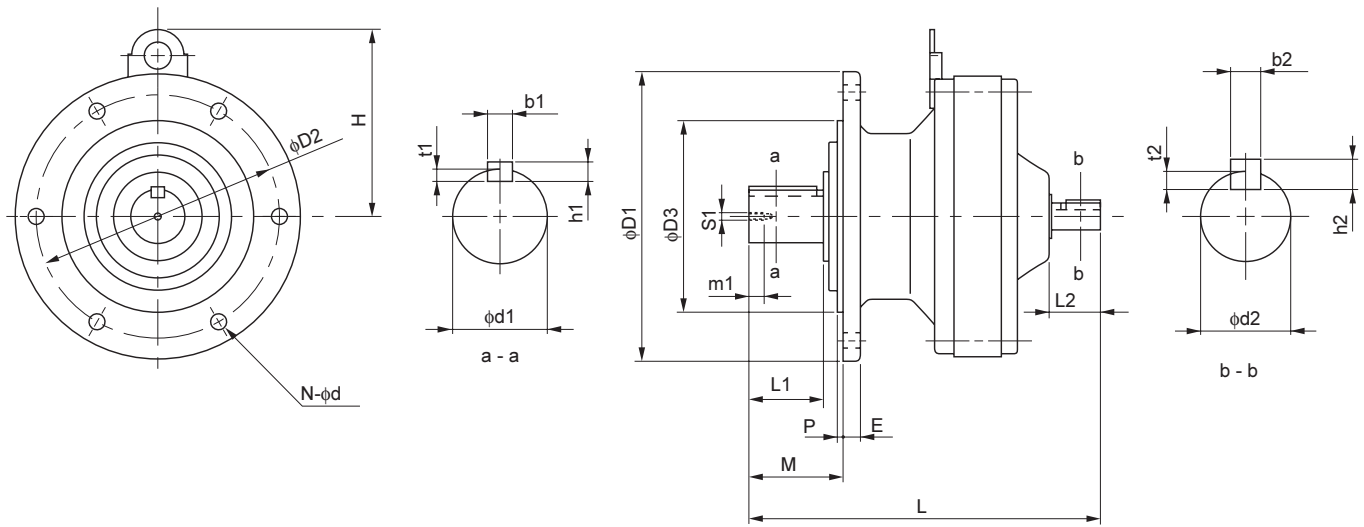

REDUCERS

Dimension Tables
CNV

Frame Size <small>Note 1</small>	L	D1	D2	D3 <small>Note 4</small>	H	M	E	P	N	d	W(kg)
606□	145	120	102	80	-	34	8	3	6	9	3.5
607□	151	160	134	110	-	42	9	3	4	11	4.5
608□	179	160	134	110	-	48	9	3	4	11	8
609□	202	160	134	110	107	48	9	3	4	11	9
610□	208	160	134	110	107	48	9	3	4	11	11
611□	218	210	180	140	116	58	11	4	6	11	13
612□	259	210	180	140	137	69	13	4	6	11	23

Model <small>Note 1</small>	Output Shaft <small>Note 2, 3</small>							Input Shaft <small>Note 2, 3</small>				
	d1	L1	b1	h1	t1	S1	m1	d2	L2	b2	h2	t2
CNV - 606□ - Ratio	14	25	5	5	3	M5	16	12	25	4	4	2.5
CNV - 607□ - Ratio	18	30	6	6	3.5	M6	16	12	25	4	4	2.5
CNV - 608□ - Ratio	22	35	6	6	3.5	M6	16	12	25	4	4	2.5
CNV - 609□ - Ratio	28	35	8	7	4	M8	20	15	25	5	5	3
CNV - 610□ - Ratio	28	35	8	7	4	M8	20	15	25	5	5	3
CNV - 611□ - Ratio	32	45	10	8	5	M8	20	15	25	5	5	3
CNV - 612□ - Ratio	38	55	10	8	5	M8	20	18	35	6	6	3.5

Note: 1. □ indicates 0 or 5, expressing combination with reduction ratio. Refer to the Selection Table for details.
 2. Dimension of shaft end diameter: Dimension tolerance conforms to JIS B 0401-1976 "h6."
 3. Dimension of shaft end key: Dimension tolerance conforms to JIS B 1301-1996 "Parallel Key."

Dimension Tables Speed Reducer (Vertical, Slow Speed Shaft Down, V-Flange Mount)

CVV - 613□ to 614□

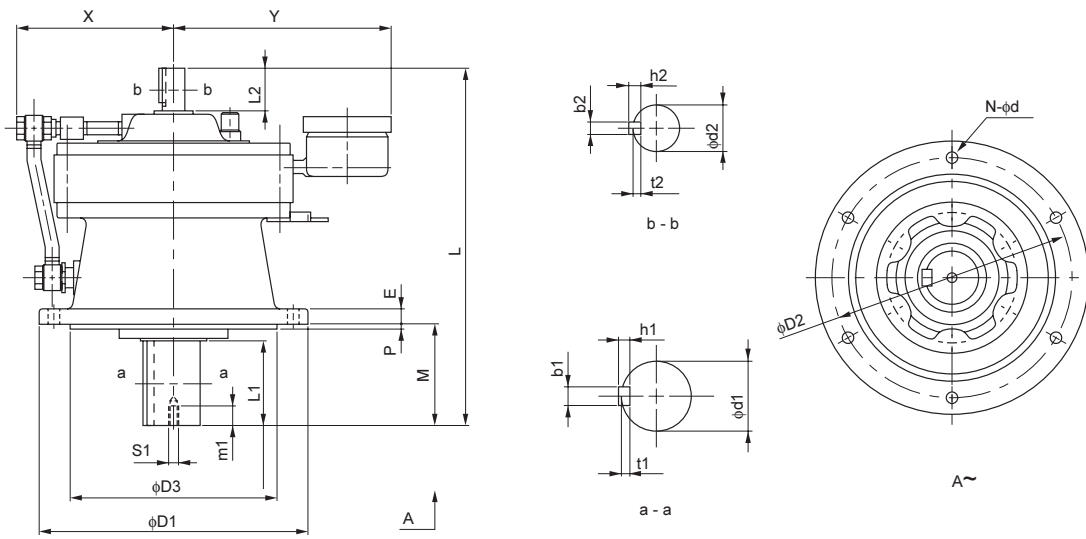

Frame Size <small>Note 1</small>	L	D1	D2	D3 <small>Note 4</small>	M	E	P	N	d	X	Y	W(kg)
613□	321	260	230	200	76	15	4	6	11	152	233	42
614□	341	260	230	200	96	15	4	6	11	152	233	43

Model <small>Note 1</small>	Output Shaft <small>Note 2, 3</small>							Input Shaft <small>Note 2, 3</small>				
	d1	L1	b1	h1	t1	S1	m1	d2	L2	b2	h2	t2
CVV - 613□ - Ratio	50	61	14	9	5.5	M10	18	22	40	6	6	3.5
CVV - 614□ - Ratio	50	81	14	9	5.5	M10	18	22	40	6	6	3.5

Note: 4. Pilot diameter (φD3): Dimension tolerance conforms to JIS B 0401-1976 "f8."
5. Dimensions in above drawings are subject to change without notice.

Dimension Tables Speed Reducer (Vertical, Slow Speed Shaft Down, V-Flange Mount)

CVV - 616□ to 6275

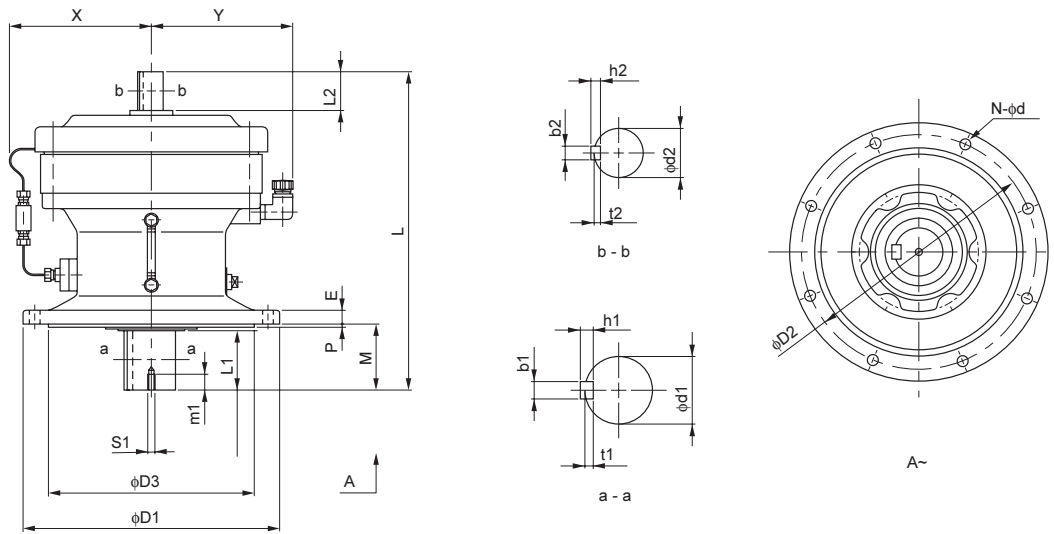

REDUCERS
Dimension Tables
CVV

Frame Size	L	D1	D2	D3	M	E	P	N	d	X	Y	W(kg)
<small>Note 1</small>				<small>Note 4</small>								
616□	413	340	310	270	89	20	4	6	11	217	200	79
617□	477	400	360	316	94	22	5	8	14	222	225	125
618□	527	430	390	345	110	22	5	8	18	237	240	150
619□	620	490	450	400	145	30	6	12	18	265	270	225
6205	678	455	405	355	204	30	5	8	22	341	287	243
6215	708	490	440	390	203	35	7	8	24	348	306	314
6225	752	535	475	415	210	35	10	8	27	352	326	396
6235	839	570	510	450	250	40	10	8	27	359	344	474
6245	877	635	560	485	250	40	10	8	33	370	371	568
6255	1040	685	610	535	295	45	10	8	33	426	399	865
6265	1150	750	660	570	360	50	10	8	39	460	431	1125
6275	1462	1160	1020	900	355	60	10	8	39	610	613	2610

Model	<small>Note 1</small>	Output Shaft							Input Shaft				
		d1	L1	b1	h1	t1	S1	m1	d2	L2	b2	h2	t2
CVV - 616□	- Ratio	60	80	18	11	7	M10	18	30	45	8	7	4
CVV - 617□	- Ratio	70	84	20	12	7.5	M12	24	35	55	10	8	5
CVV - 618□	- Ratio	80	100	22	14	9	M12	24	40	65	12	8	5
CVV - 619□	- Ratio	95	125	25	14	9	M20	34	45	70	14	9	5.5
CVV - 6205	- Ratio	100	165	28	16	10	M20	34	45	82	14	9	5.5
CVV - 6215	- Ratio	110	165	28	16	10	M20	34	50	82	14	9	5.5
CVV - 6225	- Ratio	120	165	32	18	11	M20	34	55	82	16	10	6
CVV - 6235	- Ratio	130	200	32	18	11	M24	41	60	105	18	11	7
CVV - 6245	- Ratio	140	200	36	20	12	M24	41	65	105	18	11	7
CVV - 6255	- Ratio	160	240	40	22	13	M30	49	80	130	22	14	9
CVV - 6265	- Ratio	170	300	40	22	13	M30	49	80	130	22	14	9
CVV - 6275	- Ratio	180	320	45	25	15	M30	52	90	150	25	14	9

Note: 1. □ indicates 0 or 5, expressing combination with reduction ratio. Refer to the Selection Table for details.
 2. Dimension of shaft end diameter: Dimension tolerance conforms to JIS B 0401-1976 "h6."
 3. Dimension of shaft end key: Dimension tolerance conforms to JIS B 1301-1996 "Parallel Key."

Dimension Tables Speed Reducer (Vertical, Slow Speed Shaft Down, V-Flange Mount)

CNV - 606□DA to 612□DB

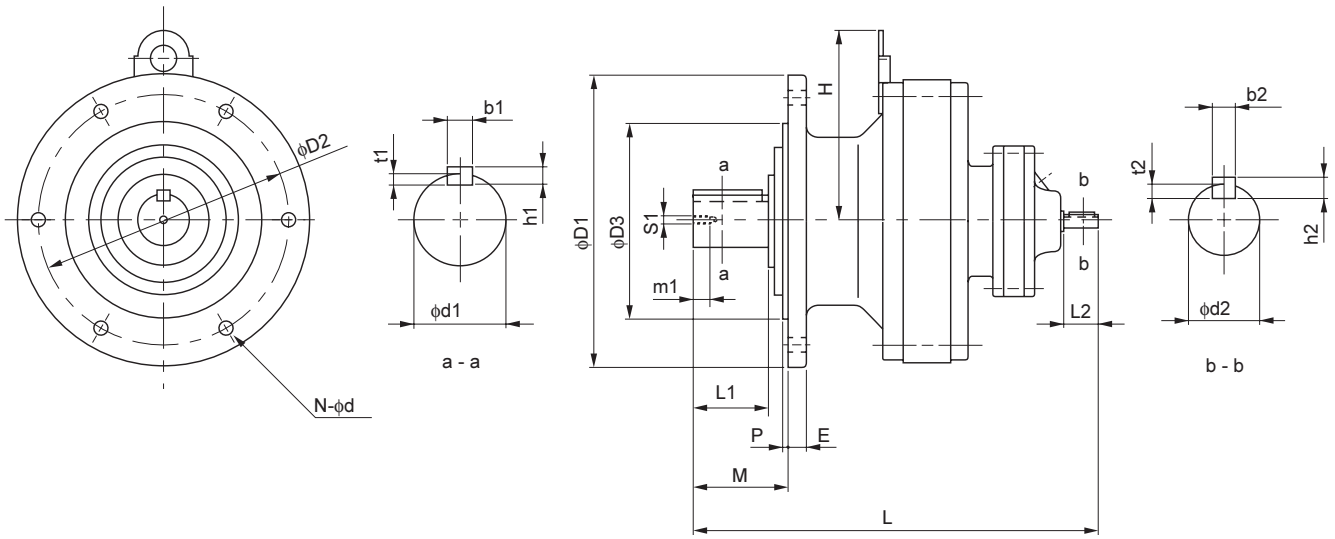

REDUCERS
Dimension Tables
CNV

Frame Size <small>Note 1</small>	L	D1	D2	D3 <small>Note 4</small>	H	M	E	P	N	d	W(kg)
606□DA	178	120	102	80	-	34	8	3	6	9	5.0
607□DA	184	160	134	110	-	42	9	3	4	11	6.7
609□DA	243	160	134	110	107	48	9	3	4	11	11
610□DA	257	160	134	110	107	48	9	3	4	11	13
612□DA	293	210	180	140	137	69	13	4	6	11	25
612□DB	312	210	180	140	137	69	13	4	6	11	29

Model <small>Note 1</small>	Output Shaft <small>Note 2, 3</small>							Input Shaft <small>Note 2, 3</small>				
	d1	L1	b1	h1	t1	S1	m1	d2	L2	b2	h2	t2
CNV - 606□DA - Ratio	14	25	5	5	3	M5	16	12	25	4	4	2.5
CNV - 607□DA - Ratio	18	30	6	6	3.5	M6	16	12	25	4	4	2.5
CNV - 609□DA - Ratio	28	35	8	7	4	M8	20	12	25	4	4	2.5
CNV - 610□DA - Ratio	28	35	8	7	4	M8	20	12	25	4	4	2.5
CNV - 612□DA - Ratio	38	55	10	8	5	M8	20	12	25	4	4	2.5
CNV - 612□DB - Ratio	38	55	10	8	5	M8	20	15	25	5	5	3

Note: 4. Pilot diameter ($\phi D3$): Dimension tolerance conforms to JIS B 0401-1976 "f8."
5. Dimensions in above drawings are subject to change without notice.

Dimension Tables Speed Reducer (Vertical, Slow Speed Shaft Down, V-Flange Mount)

CVV - 613□DA to 618□DA

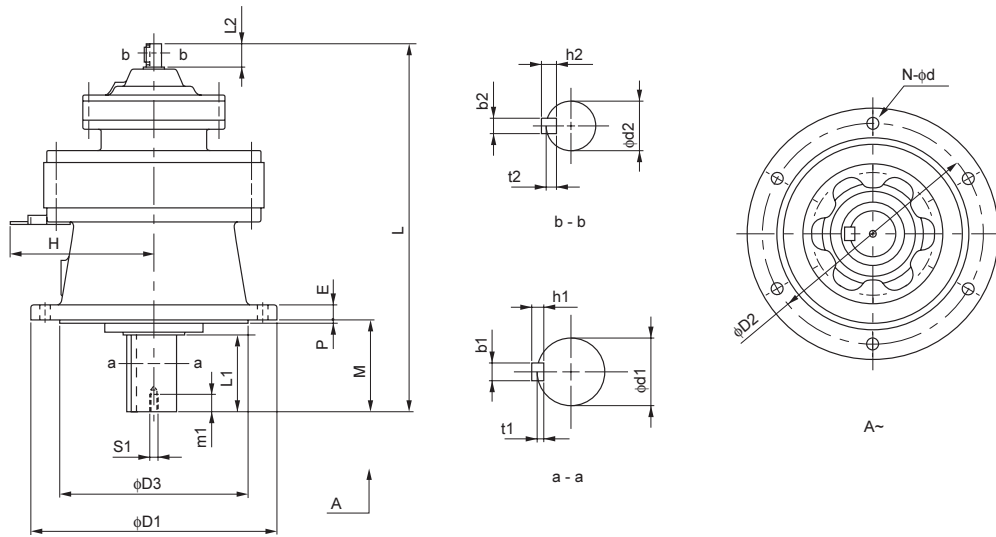

REDUCERS

Dimension Tables
CVV

Frame Size <small>Note 1</small>	L	D1	D2	D3 <small>Note 4</small>	M	E	P	N	d	H	W(kg)
613□DA	347	260	230	200	76	15	4	6	11	150	40
613□DB	363	260	230	200	76	15	4	6	11	150	43
613□DC	369	260	230	200	76	15	4	6	11	-	44
614□DA	367	260	230	200	96	15	4	6	11	150	40
614□DB	383	260	230	200	96	15	4	6	11	150	43
614□DC	389	260	230	200	96	15	4	6	11	-	44
616□DA	433	340	310	270	89	20	4	6	11	-	80
616□DB	439	340	310	270	89	20	4	6	11	-	82
617□DA	478	400	360	316	94	22	5	8	14	-	115
617□DB	484	400	360	316	94	22	5	8	14	-	117
618□DA	526	430	390	345	110	22	5	8	18	-	149

Model <small>Note 1</small>	Output Shaft <small>Note 2, 3</small>							Input Shaft <small>Note 2, 3</small>				
	d1	L1	b1	h1	t1	S1	m1	d2	L2	b2	h2	t2
CVV - 613□DA - Ratio	50	61	14	9	5.5	M10	18	12	25	4	4	2.5
CVV - 613□DB - Ratio	50	61	14	9	5.5	M10	18	15	25	5	5	3
CVV - 613□DC - Ratio	50	61	14	9	5.5	M10	18	15	25	5	5	3
CVV - 614□DA - Ratio	50	81	14	9	5.5	M10	18	12	25	4	4	2.5
CVV - 614□DB - Ratio	50	81	14	9	5.5	M10	18	15	25	5	5	3
CVV - 614□DC - Ratio	50	81	14	9	5.5	M10	18	15	25	5	5	3
CVV - 616□DA - Ratio	60	80	18	11	7	M10	18	15	25	5	5	3
CVV - 616□DB - Ratio	60	80	18	11	7	M10	18	15	25	5	5	3
CVV - 617□DA - Ratio	70	84	20	12	7.5	M12	24	15	25	5	5	3
CVV - 617□DB - Ratio	70	84	20	12	7.5	M12	24	15	25	5	5	3
CVV - 618□DA - Ratio	80	100	22	14	9	M12	24	15	25	5	5	3

Note: 1. □ indicates 0 or 5, expressing combination with reduction ratio. Refer to the Selection Table for details.
 2. Dimension of shaft end diameter: Dimension tolerance conforms to JIS B 0401-1976 "h6."
 3. Dimension of shaft end key: Dimension tolerance conforms to JIS B 1301-1996 "Parallel Key."

Dimension Tables Speed Reducer (Vertical, Slow Speed Shaft Down, V-Flange Mount)

CVV - 616□DC to 6275DA

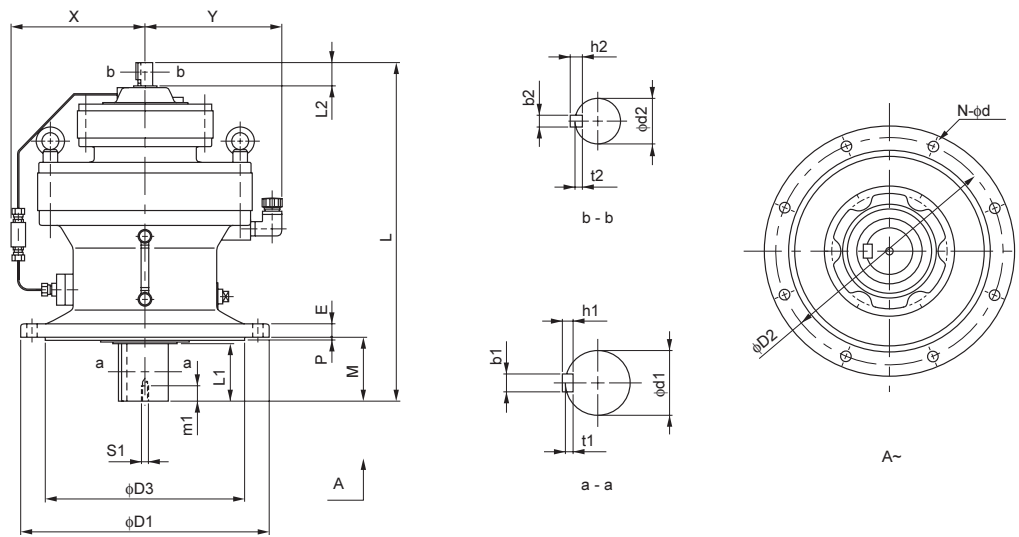

Frame Size	L	D1	D2	D3	M	E	P	N	d	X	Y	W(kg)
616□DC	462	340	310	270	89	20	4	6	11	196	200	90
617□DC	509	400	360	316	94	22	5	8	14	218	225	125
618□DB	577	430	390	345	110	22	5	8	18	233	240	171
619□DA	629	490	450	400	145	30	6	12	18	255	270	229
619□DB	653	490	450	400	145	30	6	12	18	255	270	240
6205DA	670	455	405	355	204	30	5	8	22	341	287	246
6205DB	705	455	405	355	204	30	5	8	22	341	287	258
6215DA	731	490	440	390	203	35	7	8	24	348	306	333
6215DB	780	490	440	390	203	35	7	8	24	348	306	355
6225DA	773	535	475	415	210	35	10	8	27	352	326	408
6225DB	860	535	475	415	210	35	10	8	27	352	326	455
6235DA	883	570	510	450	250	40	10	8	27	359	344	510
6235DB	938	570	510	450	250	40	10	8	27	359	344	544
6245DA	921	635	560	485	250	40	10	8	33	370	371	604
6245DB	975	635	560	485	250	40	10	8	33	370	371	633
6255DA	1081	685	610	535	295	45	10	8	33	395	399	925
6255DB	1133	685	610	535	295	45	10	8	33	395	399	993
6265DA	1243	750	660	570	360	50	10	8	39	427	431	1265
6275DA	1504	1160	1020	900	355	60	10	8	39	610	613	2660

Model	Ratio	Output Shaft							Input Shaft				
		d1	L1	b1	h1	t1	S1	m1	d2	L2	b2	h2	t2
CVV - 616□DC	Ratio	60	80	18	11	7	M10	18	18	35	6	6	3.5
CVV - 617□DC	Ratio	70	84	20	12	7.5	M12	24	18	35	6	6	3.5
CVV - 618□DB	Ratio	80	100	22	14	9	M12	24	22	40	6	6	3.5
CVV - 619□DA	Ratio	95	125	25	14	9	M20	34	18	35	6	6	3.5
CVV - 619□DB	Ratio	95	125	25	14	9	M20	34	22	40	6	6	3.5
CVV - 6205DA	Ratio	100	165	28	16	10	M20	34	18	35	6	6	3.5
CVV - 6205DB	Ratio	100	165	28	16	10	M20	34	22	40	6	6	3.5
CVV - 6215DA	Ratio	110	165	28	16	10	M20	34	22	40	6	6	3.5
CVV - 6215DB	Ratio	110	165	28	16	10	M20	34	30	45	8	7	4
CVV - 6225DA	Ratio	120	165	32	18	11	M20	34	22	40	6	6	3.5
CVV - 6225DB	Ratio	120	165	32	18	11	M20	34	35	55	10	8	5
CVV - 6235DA	Ratio	130	200	32	18	11	M24	41	30	45	8	7	4
CVV - 6235DB	Ratio	130	200	32	18	11	M24	41	40	65	12	8	5
CVV - 6245DA	Ratio	140	200	36	20	12	M24	41	30	45	8	7	4
CVV - 6245DB	Ratio	140	200	36	20	12	M24	41	40	65	12	8	5
CVV - 6255DA	Ratio	160	240	40	22	13	M30	49	35	55	10	8	5
CVV - 6255DB	Ratio	160	240	40	22	13	M30	49	45	70	14	9	5.5
CVV - 6265DA	Ratio	170	300	40	22	13	M30	49	45	70	14	9	5.5
CVV - 6275DA	Ratio	180	320	45	25	15	M30	52	45	70	14	9	5.5

Note: 4. Pilot diameter (φD3): Dimension tolerance conforms to JIS B 0401-1976 "f8."
5. Dimensions in above drawings are subject to change without notice.

Dimension Tables Speed Reducer (Foot Mount, Center Height Option)

CNH - 610H, 612H

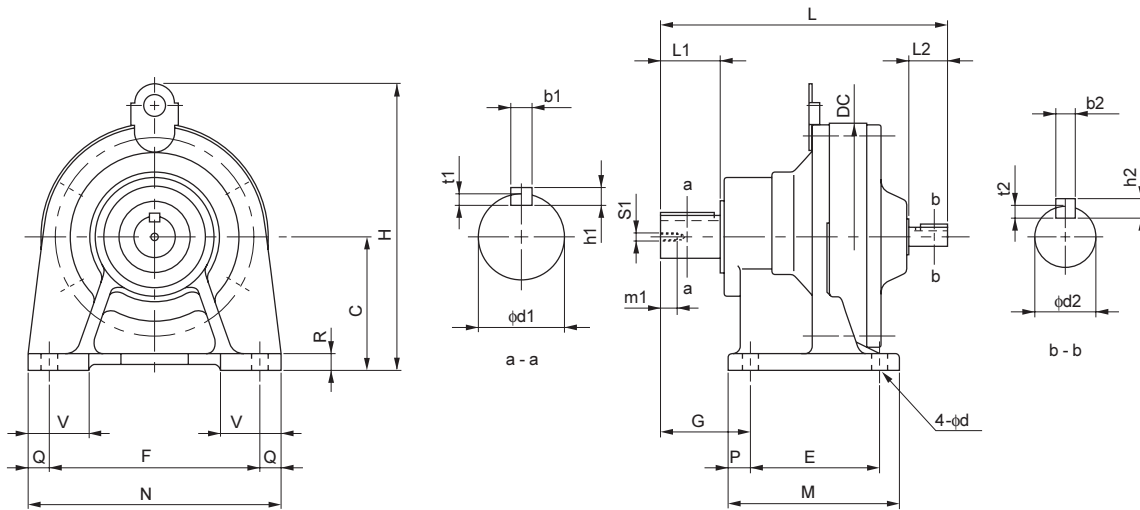

Frame Size	L	C	DC	E	F	G	H	M	N	P	Q	R	V	d	W(kg)
610H	208	120	150	90	150	60	227	135	180	15	15	12	45	11	14
612H	259	140	204	115	190	82	277	155	230	20	20	15	60	14	25

Model	Output Shaft								Input Shaft				
	d1	L1	b1	h1	t1	S1	m1	d2	L2	b2	h2	t2	
CHH - 610H - Ratio	28	35	8	7	4	M8	20	15	25	5	5	3	
CHH - 612H - Ratio	38	55	10	8	5	M8	20	18	35	6	6	3.5	

CNH - 614H, 616H

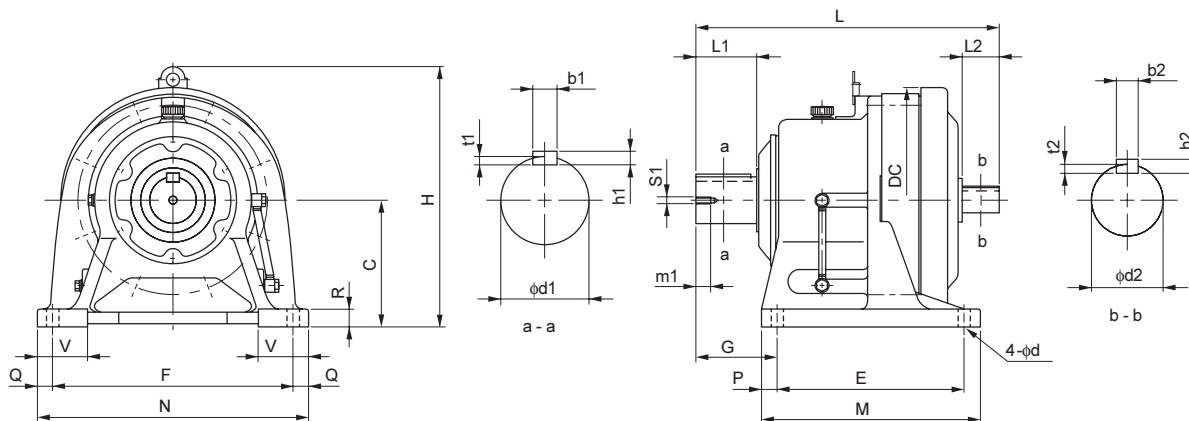

Frame size	L	C	DC	E	F	G	H	M	N	P	Q	R	V	d	W(kg)
614H	341	160	230	145	290	120	310	195	330	25	20	22	70	18	46
616H	413	200	318	150	370	139	407	238	410	44	20	25	80	18	89

Model	Output Shaft								Input Shaft				
	d1	L1	b1	h1	t1	S1	m1	d2	L2	b2	h2	t2	
CHH - 614H - Ratio	50	90	14	9	5.5	M10	18	22	40	6	6	3.5	
CHH - 616H - Ratio	60	90	18	11	7	M10	18	30	45	8	7	4	

Note: 1. Dimension of shaft end diameter: Dimension tolerance conforms to JIS B 0401-1976 "h6."
 2. Dimension of shaft end key: Dimension tolerance conforms to JIS B 1301-1996 "Parallel Key."
 3. Refer to pages F-28~30 for details on input and output shaft end dimensions.
 4. Dimensions in above drawings are subject to change without notice.

D

CYCLO® GEARMOTORS with AF Motor for Inverters

	Page
1. How to Select	
Standard Specifications	D-3
Model Selection	D-4
Reminders for Selection	D-6
Nomenclature	D-7
Precautions for Inverter Driving	D-9
2. Selection Tables	D-11
3. Dimension Tables	D-23

D CYCLO® GEARMOTORS with AF Motor for Inverters

1. How to Select

Standard Specifications of Gearmotor for Inverters

Mortor

Items	Standard Specification ^{Note 1}		Standard Specification with Built-in Brake		
Capacity Range	0.1 ~ 55kW × 4P		0.1 ~ 7.5kW × 4P FB Brake (Non-Asbestors) 11kW × 4P CMB Brake 15 ~ 22kW × 4P ESB Brake		
Enclosure	Totally enclosed fan cooled type (30kW and over: Totally enclosed air over)		Totally enclosed fan cooled type		
Power Source	380V 60Hz, 400V 60Hz, 415V 60Hz		380V 60Hz, 400V 60Hz, 415V 60Hz		
Insulation	F		F		
Time Rating	Continuous rating (6 ~ 60Hz Torque constant)		Continuous rating (6 ~ 60Hz Torque constant)		
Terminal Box Position & Lead Wire Direction	On the left side viewed from the load side. Regarding the draw out hole direction, refer to table below.		On the left side viewed from the load side. Regarding the draw out hole direction, refer to table below.		
Lead wiring (Lug type)		4P	6P	4P	6P
	6 Wires	0.1~5.5kW	-	8 Wires	0.1~5.5kW
	6 Wires	7.5~22kW ^{Note: 2}	-	8 Wires	7.5~22kW ^{Note: 2}
	6 for motor 2 for thermostat 3 for axial fan	30~55kW ^{Note: 2}	-	-	-
Standards	According to IEC				

Reducer

Items	Specifications	
Model	CYCLO 6000 Series	CYCLO 6000SK Series
Lubrication Method	Grease lubricated and oil lubricated models available	
Speed Reduction Method	Internal planetary gear mechanism with trochoidal curved tooth profile	
Direction of output shaft rotation	Single reduction	Clockwise rotation
	Double reduction	Counter-clockwise rotation
	*Note that it is different from CYCLO 6000 series single reduction type	
As observed from the load side when connected to R-U, S-V, T-W motors.		

Common to Motor and Reducer

Items	Specifications	
Ambient Conditions	Installation location	Indoor or outdoor (Minimal dust and humidity)
	Ambient temperature	-10°C ~ 40°C
	Ambient humidity	Under 85%
	Elevation	Under 1,000 meters
	Atmosphere	Well ventilated location, free of corrosive gases, explosive gases, vapors and dust.
Method of Mounting ^{Note: 3}	CHHM type-with slow speed shaft in horizontal direction and with legs. CVVM type-with slow speed shaft down in vertical direction and with mount. (No restrictions in mounting position of maintenance-free grease lubricated models, and the 2nd digit of type symbol provides "N")	
Method of coupling with driven machine	Coupling, gears, chain sprocket or belt.	
Painting	Type : Acrylic modified phtalic Colour : Equivalent to Muncell 6.5PB 3.6/8.2.	

- Note: 1. Refer to the technical section (Page F-31~57) for motor specification other than standard one.
 2. λ - Δ start is also available. Please consult us.
 3. Models for universal mounting (types with N for the second digit of nomenclature) can be manufactured for following frame sizes only. Other frame sizes require indication for mounting direction.

[Frame sizes for universal mounting direction] *□ of the frame size indicates 0, 5, or H.
 606□, 607□, 608□, 609□, 610□, 611□, 612□,
 606□DA, 607□DA, 608□DA, 609□DA, 610□DA, 612□DA, 612□DB

Direction of Withdrawing Lead Wire

Main frame mounting direction	Standard
Horizontal Type (Slow speed shaft in horizontal direction)	
Vertical Type (Slow speed shaft in vertical direction)	

Note: Whenever not specified, the above direction shall be used. When the direction of withdrawal from the terminal box is other than specified above, refer to Page F-34.

Model Selection

Select models referring to the following flowchart. Consult us if there is any question.
Step 1: Determination of Operating Condition

Determine the following condition before starting selection.

- Application
- Motor capacity (kW) and output speed or reduction ratio
- Speed control range
- Radial load and axial load
- Mounting direction (slow speed shaft direction), mounting shape
- Motor specification (with or without brake etc.)
- Other ambient conditions (temperature, humidity, indoor or outdoor, and other environments)

* Refer to Reminders for Selection in page D-6 for selections using catalogs.

Step 2: Model Selection

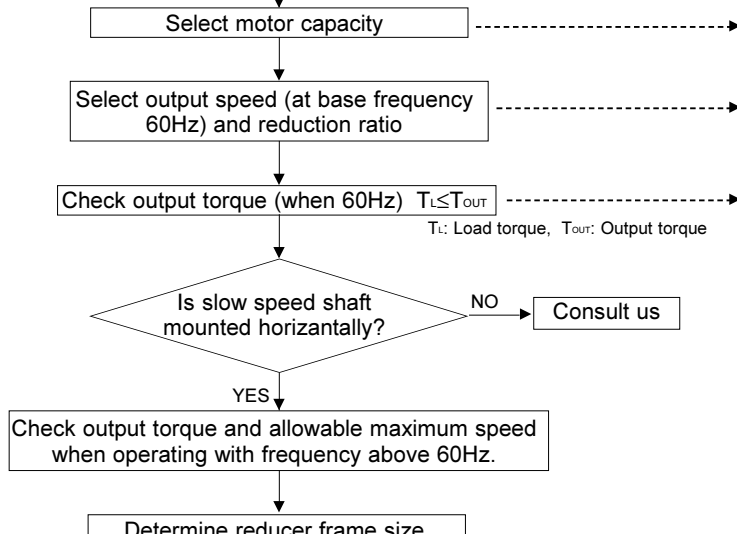

Procedure
- Open the page with selection table for your motor capacity, starting from page D-11.
- Select the cell containing close value to your output speed at 60 Hz or reduction ratio in the selection table.
- Check whether the output torque is sufficient for your usage at 60 Hz. Raise motor capacity by one frame size if the output torque is not sufficient.
- When slow speed shaft is not horizontal, contemplation is necessary on circulation system of lubrication oil. Consult us with the information of operation speed.
- Check whether only the radial load is applied on slow speed shaft. Refer to Technical Data starting at page F-10 and calculate if axial load is also applied.
- Refer to Technical Data starting at page F-10 depending on where the radial load is applied, or if any shock load is applied or not. *1 Allowable radial load for slow speed shaft in the selection table is when the load position is at the midpoint of the shaft. *2 Calculate radial load including initial tension if they are applied using chain, V-belt, synchronous belt, etc.
- Check whether the calculated radial load does not exceed allowable radial load of the slow speed shaft.
- Check whether the selected combination is sufficient for your lubrication method.
- Check whether the dimension is adequate. Consult us if it does not match your operation condition.
- Check whether the selected combination is sufficient for your operation condition, such as surrounding environment. Refer to "Standard Specifications of Gearmotor" in page D-3 or section "F. Technical Data" for checking.
- Check whether the selected motor is sufficient for your operation condition (power source, environment, thermal class, etc.).
- Determine nomenclature for selected model referring to "Nomenclature" in page D-7. Now, the selection process is complete.

Step 3: Check

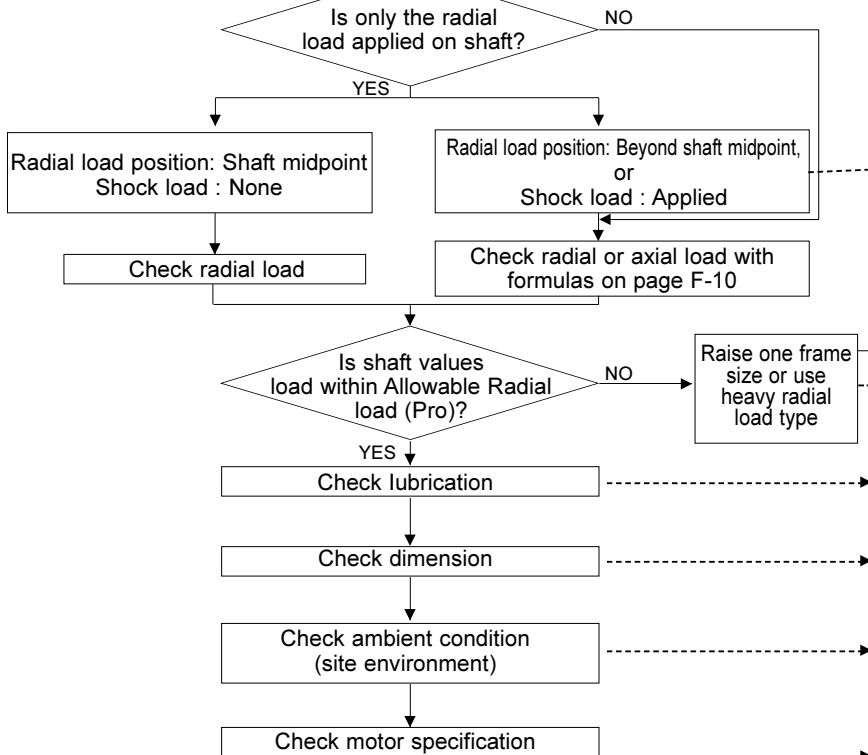

Step 4: Nomenclature Determination, Selection Complete

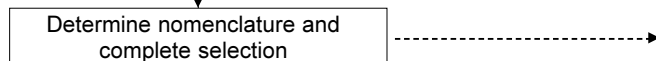

GEARMOTOR FOR INVERTERS
How to Select

Model Selection

Description of Our Selection Table

This is a brief description of our tables on page D-11 and after.

Motor capacity (kW)

Input speed (r/min) (Indicated for each number of poles at 60Hz.)

Selection Tables Gearmotors (AF Motor for Inverters)

Output Speed n ₂ r/min		Allowable MAX Speed (Horizontal)	Output Torque (60Hz) Tout		Allowable Radial Load (60Hz) Pro		Model			
6Hz	60Hz		N·m	kgf·m	N	kgf	Input Capacity Symbol	Frame Size	Suffix	Reduction Ratio
29.2	292	584 (120Hz)	171	17.4	5710	582	8	6130	- AV	6
21.9	219	438 (120Hz)	228	23.3	6360	648	8	6130	- AV	8
15.9	159	318 (120Hz)	314	32.0	7240	739	8	6130	- AV	11
13.5	135	270 (120Hz)	371	37.8	7530	768	8	6130	- AV	13
11.7	117	234 (120Hz)	428	43.6	7680	783	8	6130	- AV	15
10.3	103	206 (120Hz)	485	49.4	8230	839	8	6135	- AV	17
8.33	83.3	167 (120Hz)	599	61.0	8760	893	8	6135	- AV	21
7.00	70.0	140 (120Hz)	713	72.7	9070	925	8	6135	- AV	25
6.03	60.3	121 (120Hz)	827	84.3	14100	1430	8	6140	- AV	29
5.00	50.0	100 (120Hz)	998	102	15000	1530	8	6145	- AV	35
4.07	40.7	56.3 (83Hz)	1230	125	18900	1930	8	6160	- AV	43
3.43	34.3	47.4 (83Hz)	1450	148	19600	2000	8	6165	- AV	51
2.97	29.7	41.1 (83Hz)	1680	171	21700	2220	8	6165	- AV	59
2.46	24.6	34.0 (83Hz)	2020	206	24700	2520	8	6175	- AV	71
2.01	20.1	27.8 (83Hz)	2480	253	26400	2690	8	6175	- AV	87
1.68	16.8	33.7 (120Hz)	2810	286	37700	3840	8	6180DB	- AV	104
1.45	14.5	28.9 (120Hz)	3270	333	40000	4070	8	6185DB	- AV	121

5.5 kW

AF Motor for Inverter	
P	4
Motor Speed n ₁ r/min	1750(60Hz)

Output speed (r/min)

Allowable maximum output speed (r/min) and motor frequency (Hz) at that time

[Input capacity symbol] - [Frame size] - [Suffix (AV)] - [Reduction ratio]

* Note that "reduction ratio = normal ratio" for models with "SK" at the end of frame size (6000 SK Series with "**1" on the side of reduction ratio). (Indicated reduction ratio is the same as actual reduction ratios for other models.)

GEARMOTOR FOR INVERTERS

How to Select

Reminders for Selection (CYCLO® GEARMOTORS with AF Motor for Inverters)

Note the following when selecting CYCLO® GEARMOTORS with AF motor for inverters.

(1) Selection Table on pages D-11~21 is based on the conditions below.

1. Operation of gearmotor with constant torque and load for 10 hours/day (Load factor 1.0).
2. Maximum speed of the motor for less than 1800 r/min (1200 r/min for 6P motors) for speed control range 1:10
3. Accelerated startup possible up to 1800 r/min (1200 r/min for 6P motors) for 6P motors (with our recommended lubrication within the ambient range of standard specification).
4. Also refer to "Precautions for Inverter Driving" on page D-9.

(2) Consult us when the operation condition is other than the above.

1. When the combination of motor and CYCLO SPEED REDUCER differs with the Selection Table, such as when larger load factor is selected.
2. When using motor or inverter by other company.
3. When using standard motor by Sumitomo (any model other than AF motor for inverters).
4. When the input speed of the CYCLO SPEED REDUCER exceeds 1800 r/min (1200 r/min for 6P motors). (Allowable maximum speed (for horizontal type) is indicated in the Selection Table for reference.)
5. When the ambient temperature exceeds the range for standard type or when the used lubricant is different from our recommendation (Refer to page F-6 in Technical Data section).

(3) Contact us with following information for inverter drive for inquiry or consultation.

1. Environment (ambient temperature and such)
2. Name of the application machine
3. Operation hours and cycle
4. Load characteristics and load percentage
5. Speed control range (Minimum Hz ~ Maximum Hz)
6. Manufacturer and model of the motor or inverter driver if using the product from other companies
7. Manufacturer and brand of the lubricant if our recommended lubricant cannot be used.

Nomenclature

Slow Speed Shaft Direction	
Horizontal, slow speed shaft level	H
Vertical, slow speed shaft down	V
Vertical, slow speed shaft up	W
Universal mounting	N

Mounting style	
Foot	H
Vflange	V
Flange	F

Type of Input	
Gearmotor	M
With adaptor	JM

Special Specifications	
Standard specification	-
Special specification	S

		Motor Capacity Symbol			
4P	Capacity symbol	01	02	05	1
	kW (HP)	0.1 (1/8)	0.2 (1/4)	0.4 (1/2)	0.75 (1)
	Capacity symbol	2	3	5	8
	kW (HP)	1.5 (2)	2.2 (3)	3.7 (5)	5.5 (7.5)
6P	Capacity symbol	10	15	20	25
	kW (HP)	7.5 (10)	11 (15)	15 (20)	18.5 (25)
	Capacity symbol	30	40	50	100
	kW (HP)	22 (30)	30 (40)	37 (50)	75 (100)

Shaft specification	
Metric JIS (Standard)	-
Inch size	Y
AGMA I	YA
AGMA II	YB
AGMA III	YC
Metric DIN	G

Frame size
(Refer to Selection Tables starting from page D-11.)

Suffix	
With AF (inverter) motor	AV

With or Without Brake	
Without brake	-
With brake	B

Nominal ratio

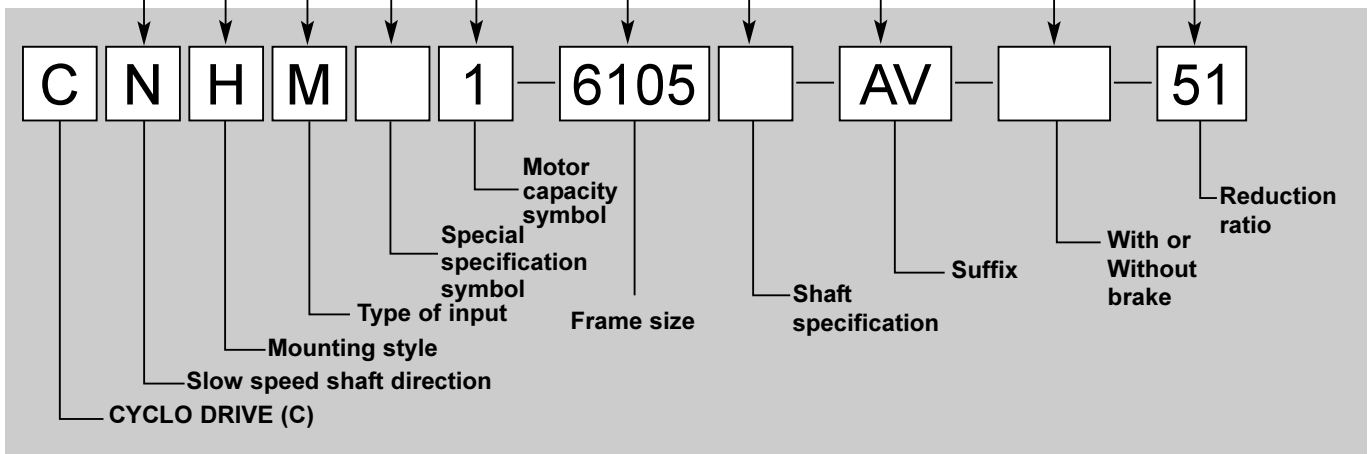

GEARMOTOR FOR INVERTERS
How to Select

Nomenclature and Product Examples

Nomenclature Examples (Gearmotor)

Example 1.

CNHM2 - 6105 - AV - 29

C:	Model	- CYCLO® DRIVE
N:	Slow speed shaft direction	- Universal direction
H:	Mounting style	- Foot
M:	Type of input	- Gearmotor type
2:	Motor capacity	- 1.5kW
6115:	Frame size	- 6105
AV:	With motor for inverter	- AV
29:	Reduction ratio	- 29

Example 2.

CHHM5 - 6175DC - AV - B - 143

C:	Model	- CYCLO® DRIVE
H:	Slow speed shaft direction	- Horizontal, level
H:	Mounting style	- Foot mount
M:	Type of input	- Gearmotor type
5:	Motor capacity	- 3.7kW
6175DC:	Frame size	- 6175DC
AV:	With motor for inverter	
B:	Brake	- With brake
143:	Reduction ratio	- 143

Application Products

Consult us for application products for CYCLO® GEARMOTORS with inverter motors. Application products are available, which are comparable to gearmotors with general motors.

Precautions for Inverter Driving

1. Constant Torque Operation

Constant torque operation needs a special motor for the inverter. Contact us especially when operation is in the frequency range less than 6 Hz.

The sensorless operation mode of our inverter HF-320 α or HF-430 permits constant torque operation of general-purpose motors at 22 kW or less. (See page D-10 for details.)

2. Operation in Frequency Range Exceeding the Base Frequency (60 Hz)

Rated output operation will be carried out in the frequency range exceeding the base frequency. Therefore, the torque will decrease as the speed increases. Select an appropriate motor capacity according to the machine load characteristics. (See Fig. D-1)

The frequency exceeding 60 Hz is regarded as the base frequency. The output torque is lower than that at 60 Hz, which is the standard base frequency, also when V/f is set for constant torque operation.

When such adjustment is made, insufficient torque may result at low frequency or during start-up.

Do not change the base frequency figure for cases other than reduction load characteristics.

3. V/f Mode Operation of General-Purpose Inverter

In the case of multiple operation of motors or V/f operation with an inverter that has no sensorless function, it is necessary to adjust the boost value in compensation for the start-up torque and slow-speed torque. Standard values are usually set before shipment from manufacturer's factory but overcurrent may result depending on the load condition and acceleration/ deceleration. In such a case, change values appropriately as follows :

- For small capacity motor and a small load, a large boost setting may cause overexcitation of a motor, leading to overcurrent. In that case, lower the boost to return to a normal value.
- For large load when overcurrent during start-up and slow-speed operation easily causes tripping, increase the boost to lower the current value. If no improvement is observed after boost adjustment, it is necessary to examine the motor capacity.

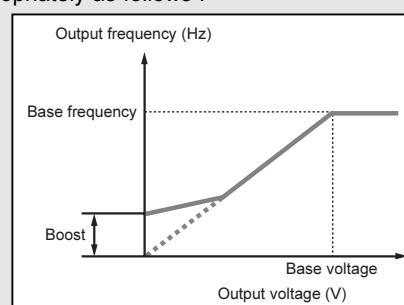

4. Operation by Sensorless Vector Inverter

Some high-performance inverters of a newest type are equipped with a sensorless vector operation function. This function is basically valid only when a motor and an inverter are operated in one-to-one correspondence. The function does not apply to multiple operation or pole-change operation. Products to which the auto-tuning method is applied do not need adjustment as in the case of V/f operation due to automatic control of the motor characteristics. Vector operation is carried out on the basis of the motor data read by the inverter, and operation is controlled instantaneously in accordance with the load condition to continue optimal operation.

When the wiring distance between the motor and inverter becomes long (20 m or more), compensation may be necessary according to the drop in the line impedance. Select sufficiently thick cables for long distance wiring. Consult us for long distance wiring.

5. Output Torque Characteristics of Motor

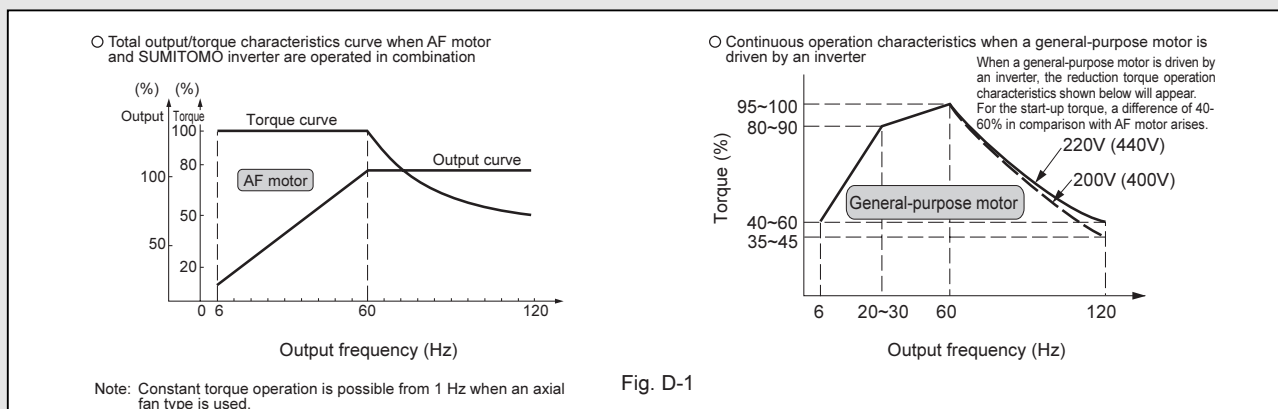

6. Motor Temperature Rise

When a general-purpose motor is combined with an inverter for variable-speed operation, the motor temperature rise may be slightly greater than if the motor is operated by a commercial power supply.

Possible causes are shown below:

Influence of output waveform: Unlike a commercial power supply, the output waveform of an inverter is not a complete sine wave but includes harmonics; therefore, motor damage will increase, raising the temperature slightly higher.

Decrease in motor cooling effect during slow-speed operation:

A motor is cooled by its own fan. Therefore, when the motor speed is decreased by an inverter, the quantity of cooling air decreases, reducing the cooling effect.

When operating the motor at frequencies lower than commercial power supply, reduce the load torque to decrease the temperature rise or use a special motor designed for inverter operation.

Constant Torque Operation of General-Purpose Motors

Operation with the following characteristics is possible when our inverters HF-320 α and HF-430 series are used for sensorless control in combination with our general-purpose motors (22 kW or less).

A combination with a motor of standard frame size can be used for constant torque operation where an AF motor with a reducer of a larger frame size has conventionally been used.

- Note:
1. To select the combination with CYCLO, examine the lubrication method and torque during slow speed operation and rated output operation. Specify that inverter operation is desired when placing an order (Refer to page C-6).
 2. Contact us for 400V class model because insulation selection is necessary for inverter operation.
 3. When a motor with brakes is to be operated for a long time at slow speed, the cooling effect of the fan will decrease and the brake temperature will rise substantially. Contact us for details.
 4. Contact us for details when a general-purpose motor is to be operated under V/F control. (Contact us also when SF-320 α series is to be used.)

kW	Motor frame size	Thermal class	Applicable frequency range	Constant torque range	Constant output range	Applicable inverter
0.1	F63S	E	6~120Hz	6~60Hz (1:10)	60~120Hz	HF-320 α Sensorless control
0.2	F63M					
0.4	F71M					
0.75	F80M					
1.5	F90L	B	6~120Hz	20~60Hz (1:3)	60~120Hz	HF-430 Sensorless control
2.2	F100L					
3.7	F112M					
5.5	F132S					
7.5	F132M					
11	F160M					
15	G160L					
22	F180MG					
			6~110Hz		60~110Hz	

HF-320 α and HF-430 Output Torque Characteristics During Sensorless Mode Operation

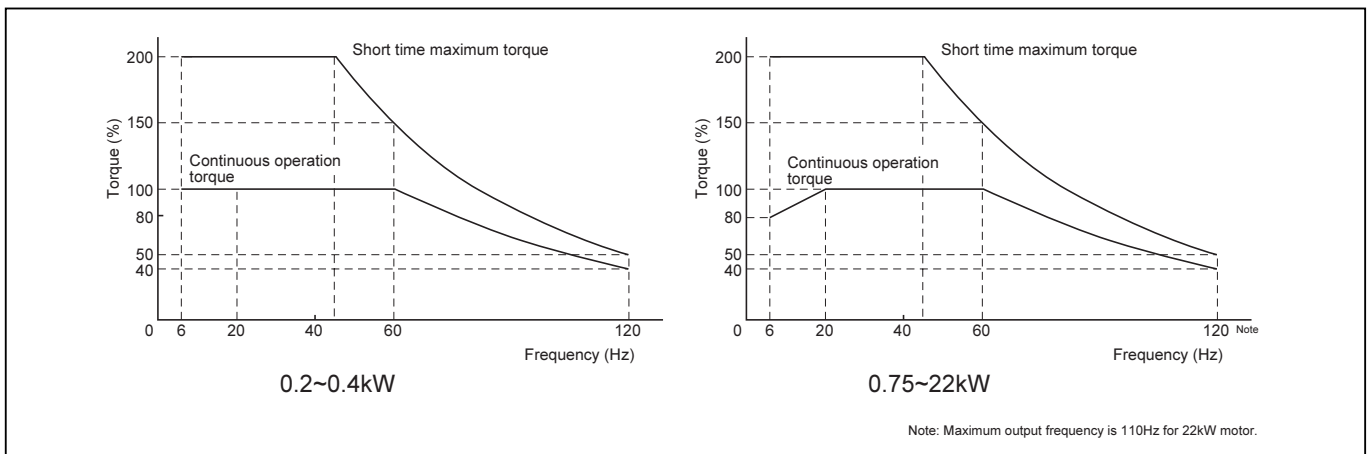

Output torque 100% is the motor rating at 60Hz.

Continuous operation torque: Allowable torque value enabling continuous operation with motor temperature rise, fulfilling standards.

Short-time operation torque: Maximum torque emitted by motor when driven with inverter. Motor can be operated for 1 minute at this torque value.

Use AF motor when constant torque is required for capacity 30kW and above.

D CYCLO® GEARMOTORS With AF Motor for Inverters

2. Selection Tables

Selection Tables Gearmotors (AF Motor for Inverters)

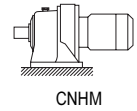

0.1 kW	AF Motor for Inverters	
	P	4
	Motor Speed n ₁ r/min	1750(60Hz)

Output Speed n ₂ r/min			Output Torque (60Hz) Tout		Allowable Radial Load (60Hz) Pro		Model				Dim. Page
6Hz	60Hz	Allowable MAX Speed (Horizontal)	N·m	kgf·m	N	kgf	Input Capacity - Symbol	Frame Size	Suffix	Reduction Ratio	CNHM
29.2	292	584 (120Hz)	3.11	0.317	756	77.1	01 -	6060	- AV	- 6	D-29
21.9	219	438 (120Hz)	4.15	0.423	866	88.3	01 -	6060	- AV	- 8	D-29
15.9	159	318 (120Hz)	5.70	0.581	1180	120	01 -	6060	- AV	- 11	D-29
13.5	135	270 (120Hz)	6.74	0.687	1180	120	01 -	6060	- AV	- 13	D-29
11.7	117	234 (120Hz)	7.78	0.793	1180	120	01 -	6060	- AV	- 15	D-29
10.3	103	206 (120Hz)	8.81	0.898	1180	120	01 -	6060	- AV	- 17	D-29
8.33	83.3	167 (120Hz)	10.9	1.11	1180	120	01 -	6060	- AV	- 21	D-29
7.00	70.0	140 (120Hz)	13.0	1.32	1180	120	01 -	6060	- AV	- 25	D-29
6.03	60.3	121 (120Hz)	15.0	1.53	1180	120	01 -	6060	- AV	- 29	D-29
5.00	50.0	100 (120Hz)	18.1	1.85	1180	120	01 -	6060	- AV	- 35	D-29
4.07	40.7	81.4 (120Hz)	22.3	2.27	1180	120	01 -	6065	- AV	- 43	D-29
3.43	34.3	68.6 (120Hz)	26.4	2.70	1770	180	01 -	6070	- AV	- 51	D-29
2.97	29.7	59.4 (120Hz)	30.6	3.12	1770	180	01 -	6070	- AV	- 59	D-29
2.46	24.6	49.2 (120Hz)	36.8	3.75	2560	261	01 -	6080	- AV	- 71	D-29
2.01	20.1	40.2 (120Hz)	45.1	4.60	2560	261	01 -	6085	- AV	- 87	D-29
1.68	16.8	33.7 (120Hz)	51.1	5.21	1770	180	01 -	6075DA	- AV	- 104	D-33
1.45	14.5	28.9 (120Hz)	59.4	6.06	3340	340	01 -	6090DA	- AV	- 121	D-33
1.22	12.2	24.5 (120Hz)	70.2	7.16	3340	340	01 -	6090DA	- AV	- 143	D-33
1.06	10.6	21.2 (120Hz)	81.0	8.26	3340	340	01 -	6090DA	- AV	- 165	D-33
0.897	8.97	17.9 (120Hz)	95.8	9.76	3340	340	01 -	6090DA	- AV	- 195	D-33
0.758	7.58	15.2 (120Hz)	113	11.6	3340	340	01 -	6090DA	- AV	- 231	D-33
0.641	6.41	12.8 (120Hz)	134	13.7	3340	340	01 -	6095DA	- AV	- 273	D-33
0.549	5.49	11.0 (120Hz)	157	16.0	3280	334	01 -	6095DA	- AV	- 319	D-33
0.464	4.64	9.3 (120Hz)	185	18.9	3230	329	01 -	6095DA	- AV	- 377	D-33
0.370	3.70	7.4 (120Hz)	232	23.7	5400	550	01 -	6105DA	- AV	- 473	D-33
0.313	3.13	6.3 (120Hz)	275	28.0	5400	550	01 -	6105DA	- AV	- 559	D-33
0.270	2.70	5.4 (120Hz)	319	32.5	9810	1000	01 -	6120DA	- AV	- 649	D-33
0.239	2.39	4.8 (120Hz)	359	36.6	9810	1000	01 -	6120DA	- AV	- 731	D-33
0.208	2.08	4.2 (120Hz)	413	42.1	9810	1000	01 -	6125DA	- AV	- 841	D-33
0.174	1.74	3.5 (120Hz)	493	50.2	9810	1000	01 -	6125DA	- AV	- 1003	D-33
0.140	1.40	2.8 (120Hz)	612	62.4	9810	1000	01 -	6125DA	- AV	- 1247	D-33

SELECTION TABLES
GEARMOTOR
FOR INVERTERS
0.1 kW

- Note: 1. Allowable radial load Pro is the value at the midpoint of the output shaft.
 2. Lubrication method is different for each model. Refer to "Lubrication" section in page F-4~F-5 for details.
 3. "6" at the end of "input capacity symbol" indicates models with 6P motor. Other models come with 4P motor.
 4. Refer to page D-9 "Precautions for Inverter Driving" when operating beyond 6~60 Hz.

Selection Tables 600SK Series•Reducer

0.2 kW	AF Motor for Inverters	
	P	4
	Motor Speed n ₁ r/min	1750(60Hz)

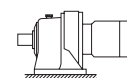

CHHM/CNHM

Output Speed n ₂ r/min			Output Torque (60Hz) Tout N·m kgf·m	Allowable Radial Load (60Hz) Pro N kgf		Model				Dim. Page				
6Hz	60Hz	Allowable MAX Speed (Horizontal)				Input Capacity - Symbol	Frame Size	Suffix	Reduction Ratio	CNHM				
29.2	292	584 (120Hz)	6.22	0.634	751	76.6	02	-	6060	-	AV	-	6	D-29
21.9	219	438 (120Hz)	8.29	0.846	859	87.5	02	-	6060	-	AV	-	8	D-29
15.9	159	318 (120Hz)	11.4	1.16	1170	119	02	-	6060	-	AV	-	11	D-29
13.5	135	270 (120Hz)	13.5	1.37	1180	120	02	-	6060	-	AV	-	13	D-29
11.7	117	234 (120Hz)	15.6	1.59	1180	120	02	-	6060	-	AV	-	15	D-29
10.3	103	206 (120Hz)	17.6	1.80	1180	120	02	-	6060	-	AV	-	17	D-29
8.33	83.3	167 (120Hz)	21.8	2.22	1180	120	02	-	6065	-	AV	-	21	D-29
7.00	70.0	140 (120Hz)	25.9	2.64	1770	180	02	-	6070	-	AV	-	25	D-29
6.03	60.3	121 (120Hz)	30.1	3.07	1770	180	02	-	6070	-	AV	-	29	D-29
5.00	50.0	100 (120Hz)	36.3	3.70	1770	180	02	-	6070	-	AV	-	35	D-29
4.07	40.7	81.4 (120Hz)	44.6	4.54	1770	180	02	-	6075	-	AV	-	43	D-29
3.43	34.3	68.6 (120Hz)	52.9	5.39	2560	261	02	-	6085	-	AV	-	51	D-29
2.97	29.7	59.4 (120Hz)	61.2	6.24	2560	261	02	-	6085	-	AV	-	59	D-29
2.46	24.6	49.2 (120Hz)	73.6	7.50	3290	335	02	-	6090	-	AV	-	71	D-29
2.01	20.1	40.2 (120Hz)	90.2	9.20	3340	340	02	-	6090	-	AV	-	87	D-29
1.68	16.8	33.7 (120Hz)	102	10.4	3340	340	02	-	6090DA	-	AV	-	104	D-33
1.47	14.7	29.4 (120Hz)	123	12.6	5400	550	02	-	6100	-	AV	-	119	D-29
1.45	14.5	28.9 (120Hz)	119	12.1	3340	340	02	-	6095DA	-	AV	-	121	D-33
1.22	12.2	24.5 (120Hz)	140	14.3	3340	340	02	-	6095DA	-	AV	-	143	D-33
1.06	10.6	21.2 (120Hz)	162	16.5	3340	340	02	-	6095DA	-	AV	-	165	D-33
0.897	8.97	17.9 (120Hz)	192	19.5	3340	340	02	-	6095DA	-	AV	-	195	D-33
0.758	7.58	15.2 (120Hz)	227	23.1	5400	550	02	-	6105DA	-	AV	-	231	D-33
0.641	6.41	12.8 (120Hz)	268	27.3	5400	550	02	-	6105DA	-	AV	-	273	D-33
0.549	5.49	11.0 (120Hz)	313	31.9	9810	1000	02	-	6120DA	-	AV	-	319	D-33
0.464	4.64	9.3 (120Hz)	370	37.7	9810	1000	02	-	6120DA	-	AV	-	377	D-33
0.370	3.70	7.4 (120Hz)	465	47.4	9810	1000	02	-	6125DA	-	AV	-	473	D-33
0.313	3.13	6.3 (120Hz)	549	56.0	9810	1000	02	-	6125DA	-	AV	-	559	D-33
0.270	2.70	5.4 (120Hz)	638	65.0	14700	1500	02	-	6130DA	-	AV	-	649	D-34
0.239	2.39	4.8 (120Hz)	718	73.2	14700	1500	02	-	6135DA	-	AV	-	731	D-34
0.208	2.08	4.2 (120Hz)	826	84.2	14700	1500	02	-	6135DA	-	AV	-	841	D-34
0.174	1.74	3.5 (120Hz)	985	100	14700	1500	02	-	6135DA	-	AV	-	1003	D-34
0.140	1.40	2.8 (120Hz)	1220	125	16000	1630	02	-	6145DA	-	AV	-	1247	D-34
0.085	0.85	1.7 (120Hz)	2030	207	22100	2250	02	-	6165DA	-	AV	-	2065	D-34
0.058	0.58	1.2 (120Hz)	2990	305	29500	3010	02	-	6175DA	-	AV	-	3045	D-34

Selection Tables
 0.2 kW
 GEARMOTOR
 FOR INVERTERS

- "*1" indicate models with reduction ratios equal to nominal ratio. Refer to Table A-3 "6000 SK Series (Actual Reduction Ratio)" on page A-4 for actual reduction ratio. Indicated reduction ratio is the same as actual reduction ratio for other models.
- "*2" indicate models requiring increased capacity for inverters, for certain operation conditions (ambient temperature, load condition, etc.).
- Consult us for vertical types. Lubrication oil and system requires contemplation.

Selection Tables Gearmotors (AF Motor for Inverters)

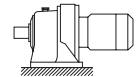

CHHM/CNHM

0.4 kW	AF Motor for Inverters	
	P	4
	Motor Speed n ₁	r/min
		1750(60Hz)

Output Speed n ₂ r/min			Output Torque (60Hz) Tout		Allowable Radial Load (60Hz) Pro		Model				Dim. Page
6Hz	60Hz	Allowable MAX Speed (Horizontal)	N·m	kgf·m	N	kgf	Input Capacity Symbol	Frame Size	Suffix	Reduction Ratio	CNHM CHHM
70.0	700	1400 (120Hz)	5.18	0.528	1120	114	05	- 6070SK	- AV	- 2.5 *1	D-28
58.3	583	1167 (120Hz)	6.22	0.634	1180	120	05	- 6070SK	- AV	- 3 *1	D-28
43.8	438	875 (120Hz)	8.29	0.846	1290	131	05	- 6070SK	- AV	- 4 *1	D-28
35.0	350	700 (120Hz)	10.4	1.06	1290	132	05	- 6070SK	- AV	- 5 *1	D-28
29.2	292	584 (120Hz)	12.4	1.27	1290	132	05	- 6070SK	- AV	- 6 *1	D-28
29.2	292	584 (120Hz)	12.4	1.27	1810	184	05	- 6080	- AV	- 6	D-29
21.9	219	438 (120Hz)	16.6	1.69	1430	145	05	- 6070SK	- AV	- 8 *1	D-28
21.9	219	438 (120Hz)	16.6	1.69	1960	200	05	- 6080	- AV	- 8	D-29
17.5	175	350 (120Hz)	20.7	2.11	1590	162	05	- 6070SK	- AV	- 10 *1	D-28
15.9	159	318 (120Hz)	22.8	2.33	2160	220	05	- 6080	- AV	- 11	D-29
13.5	135	270 (120Hz)	27.0	2.75	2320	237	05	- 6080	- AV	- 13	D-29
11.7	117	234 (120Hz)	31.1	3.17	2400	245	05	- 6080	- AV	- 15	D-29
10.3	103	206 (120Hz)	35.3	3.59	2510	256	05	- 6080	- AV	- 17	D-29
8.33	83.3	167 (120Hz)	43.5	4.44	2450	250	05	- 6085	- AV	- 21	D-29
7.00	70.0	140 (120Hz)	51.8	5.28	2520	256	05	- 6085	- AV	- 25	D-29
6.03	60.3	121 (120Hz)	60.1	6.13	2560	261	05	- 6085	- AV	- 29	D-29
5.00	50.0	100 (120Hz)	72.6	7.40	3340	340	05	- 6090	- AV	- 35	D-29
4.07	40.7	81.4 (120Hz)	89.2	9.09	3340	340	05	- 6090	- AV	- 43	D-29
3.43	34.3	68.6 (120Hz)	106	10.8	3340	340	05	- 6095	- AV	- 51	D-29
2.97	29.7	59.4 (120Hz)	122	12.5	5400	550	05	- 6100	- AV	- 59	D-29
2.46	24.6	49.2 (120Hz)	147	15.0	5400	550	05	- 6105	- AV	- 71	D-29
2.01	20.1	40.2 (120Hz)	180	18.4	5400	550	05	- 6105	- AV	- 87	D-29
1.68	16.8	33.7 (120Hz)	204	20.8	9810	1000	05	- 6120DB	- AV	- 104	D-33
1.45	14.5	28.9 (120Hz)	238	24.2	9810	1000	05	- 6120DB	- AV	- 121	D-33
1.22	12.2	24.5 (120Hz)	281	28.6	9810	1000	05	- 6120DB	- AV	- 143	D-33
1.06	10.6	21.2 (120Hz)	324	33.0	9810	1000	05	- 6120DB	- AV	- 165	D-33
0.897	8.97	17.9 (120Hz)	383	39.1	9810	1000	05	- 6120DB	- AV	- 195	D-33
0.758	7.58	15.2 (120Hz)	454	46.3	9810	1000	05	- 6125DB	- AV	- 231	D-33
0.641	6.41	12.8 (120Hz)	536	54.7	9810	1000	05	- 6125DB	- AV	- 273	D-33
0.549	5.49	11.0 (120Hz)	627	63.9	9810	1000	05	- 6125DB	- AV	- 319	D-33
0.464	4.64	9.3 (120Hz)	741	75.5	14700	1500	05	- 6135DB	- AV	- 377	D-34
0.370	3.70	7.4 (120Hz)	929	94.7	14700	1500	05	- 6135DB	- AV	- 473	D-34
0.313	3.13	6.3 (120Hz)	1100	112	16000	1630	05	- 6145DB	- AV	- 559	D-34
0.270	2.70	5.4 (120Hz)	1280	130	16000	1630	05	- 6145DB	- AV	- 649	D-34
0.239	2.39	4.8 (120Hz)	1440	146	22100	2250	05	- 6165DA	- AV	- 731	D-34
0.208	2.08	4.2 (120Hz)	1650	168	22100	2250	05	- 6165DA	- AV	- 841	D-34
0.174	1.74	3.5 (120Hz)	1970	201	22100	2250	05	- 6165DA	- AV	- 1003	D-34
0.140	1.40	2.8 (120Hz)	2450	250	29500	3010	05	- 6175DA	- AV	- 1247	D-34
0.118	1.18	2.4 (120Hz)	2910	296	29500	3010	05	- 6175DA	- AV	- 1479	D-34
0.069	0.69	1.4 (120Hz)	4980	508	41600	4240	05	- 6185DA	- AV	- 2537	D-34

- Notes: 1. Allowable radial load Pro is the value at the midpoint of the output shaft.
 2. Lubrication method is different for each model. Refer to "Lubrication" section in page F-4~F-5 for details.
 3. "6" at the end of "input capacity symbol" indicates models with 6P motor. Other models come with 4P motor.
 4. Refer to page D-9 "Precautions for Inverter Driving" when operating beyond 6~60 Hz.

SELECTION TABLES
GEARMOTOR
FOR INVERTERS
0.4 kW

Selection Tables Gearmotors (AF Motor for Inverters)

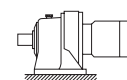

CHHM/CNHM

0.75 kW	AF Motor for Inverters	
	P	4
	Motor Speed n ₁	r/min 1750(60Hz)

Output Speed n ₂ r/min			Output Torque (60Hz) Tout N·m kgf·m	Allowable Radial Load (60Hz) Pro N kgf		Model				Dim. Page	
6Hz	60Hz	Allowable MAX Speed (Horizontal)		N	kgf	Input Capacity - Symbol	Frame Size -	Suffix -	Reduction Ratio -	CNHM CHHM	
											CHHM
70.0	700	1400 (120Hz)	9.72	0.991	1190	121	1 -	6080SK -	AV -	2.5 *1	D-28
58.3	583	1167 (120Hz)	11.7	1.19	1250	127	1 -	6080SK -	AV -	3 *1	D-28
43.8	438	875 (120Hz)	15.6	1.59	1350	138	1 -	6080SK -	AV -	4 *1	D-28
35.0	350	700 (120Hz)	19.4	1.98	1460	149	1 -	6080SK -	AV -	5 *1	D-28
29.2	292	584 (120Hz)	23.3	2.38	1520	155	1 -	6080SK -	AV -	6 *1	D-28
29.2	292	584 (120Hz)	23.3	2.38	2670	273	1 -	6090 -	AV -	6	D-29
21.9	219	438 (120Hz)	31.1	3.17	1590	162	1 -	6080SK -	AV -	8 *1	D-28
21.9	219	438 (120Hz)	31.1	3.17	2980	304	1 -	6090 -	AV -	8	D-29
17.5	175	350 (120Hz)	38.9	3.96	1680	171	1 -	6080SK -	AV -	10 *1	D-28
15.9	159	318 (120Hz)	42.8	4.36	3340	340	1 -	6090 -	AV -	11	D-29
13.5	135	270 (120Hz)	50.5	5.15	3340	340	1 -	6090 -	AV -	13	D-29
11.7	117	234 (120Hz)	58.3	5.95	3340	340	1 -	6090 -	AV -	15	D-29
10.3	103	206 (120Hz)	66.1	6.74	3340	340	1 -	6090 -	AV -	17	D-29
8.33	83.3	167 (120Hz)	81.7	8.32	3340	340	1 -	6090 -	AV -	21	D-29
7.00	70.0	140 (120Hz)	97.2	9.91	3340	340	1 -	6095 -	AV -	25	D-29
6.03	60.3	121 (120Hz)	113	11.5	3340	340	1 -	6095 -	AV -	29	D-29
5.00	50.0	100 (120Hz)	136	13.9	3330	339	1 -	6095 -	AV -	35	D-29
4.07	40.7	81.4 (120Hz)	167	17.0	5400	550	1 -	6100 -	AV -	43	D-29
3.43	34.3	68.6 (120Hz)	198	20.2	5390	549	1 -	6105 -	AV -	51	D-29
2.97	29.7	59.4 (120Hz)	229	23.4	7610	776	1 -	6110 -	AV -	59	D-29
2.46	24.6	49.2 (120Hz)	276	28.1	7610	776	1 -	6115 -	AV -	71	D-29
2.01	20.1	40.2 (120Hz)	338	34.5	7610	776	1 -	6115 -	AV -	87	D-29
1.68	16.8	33.7 (120Hz)	383	39.1	9810	1000	1 -	6120DB -	AV -	104	D-33
1.45	14.5	28.9 (120Hz)	446	45.4	9810	1000	1 -	6125DB -	AV -	121	D-33
1.22	12.2	24.5 (120Hz)	527	53.7	9810	1000	1 -	6125DB -	AV -	143	D-33
1.06	10.6	21.2 (120Hz)	608	62.0	9810	1000	1 -	6125DB -	AV -	165	D-33
0.897	8.97	17.9 (120Hz)	718	73.2	14700	1500	1 -	6135DB -	AV -	195	D-34
0.758	7.58	15.2 (120Hz)	851	86.7	14700	1500	1 -	6135DB -	AV -	231	D-34
0.641	6.41	12.8 (120Hz)	1010	103	16000	1630	1 -	6145DB -	AV -	273	D-34
0.549	5.49	11.0 (120Hz)	1180	120	16000	1630	1 -	6145DB -	AV -	319	D-34
0.464	4.64	9.3 (120Hz)	1390	142	22100	2250	1 -	6165DA -	AV -	377	D-34
0.370	3.70	7.4 (120Hz)	1740	178	22100	2250	1 -	6165DA -	AV -	473	D-34
0.313	3.13	6.3 (120Hz)	2060	210	22100	2250	1 -	6165DA -	AV -	559	D-34
0.270	2.70	5.4 (120Hz)	2390	244	29500	3010	1 -	6175DA -	AV -	649	D-34
0.239	2.39	4.8 (120Hz)	2690	274	29500	3010	1 -	6175DA -	AV -	731	D-34
0.208	2.08	4.2 (120Hz)	3100	316	29500	3010	1 -	6175DA -	AV -	841	D-34
0.174	1.74	3.5 (120Hz)	3690	377	41700	4250	1 -	6185DA -	AV -	1003	D-34
0.140	1.40	2.8 (120Hz)	4590	468	41700	4250	1 -	6185DA -	AV -	1247	D-34
0.118	1.18	2.4 (120Hz)	5450	555	59000	6010	1 -	6195DA -	AV -	1479	D-35
0.095	0.95	1.9 (120Hz)	6810	694	59000	6010	1 -	6195DA -	AV -	1849	D-35
0.085	0.85	1.7 (120Hz)	7610	775	58200	5940	1 -	6195DA -	AV -	2065	D-35
0.069	0.69	1.4 (120Hz)	9350	953	84100	8570	1 -	6205DA -	AV -	2537 *2	D-36

- **1" indicate models with reduction ratios equal to nominal ratio. Refer to Table A-3 "6000 SK Series (Actual Reduction Ratio)" on page A-4 for actual reduction ratio. Indicated reduction ratio is the same as actual reduction ratio for other models.
- **2" indicate models requiring increased capacity for inverters, for certain operation conditions (ambient temperature, load condition, etc.).
- Consult us for vertical types. Lubrication oil and system requires contemplation.

Selection Tables Gearmotors (AF Motor for Inverters)

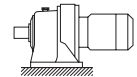

CHHM/CNHM

1.5 kW	AF Motor for Inverters	
	P	4
	Motor Speed n ₁	r/min 1750(60Hz)

Output Speed n ₂ r/min			Output Torque (60Hz) Tout		Allowable Radial Load (60Hz) Pro		Model				Dim. Page
6Hz	60Hz	Allowable MAX Speed (Horizontal)	N·m	kgf·m	N	kgf	Input Capacity Symbol	Frame Size	Suffix	Reduction Ratio	CNHM CHHM
70.0	700	1400 (120Hz)	19.4	1.98	2050	209	2 -	6090SK	- AV	- 2.5 *1	D-28
58.3	583	1167 (120Hz)	23.3	2.38	2120	216	2 -	6090SK	- AV	- 3 *1	D-28
43.8	438	875 (120Hz)	31.1	3.17	2370	242	2 -	6090SK	- AV	- 4 *1	D-28
35.0	350	700 (120Hz)	38.9	3.96	2490	254	2 -	6090SK	- AV	- 5 *1	D-28
29.2	292	584 (120Hz)	46.7	4.76	2530	258	2 -	6090SK	- AV	- 6 *1	D-28
29.2	292	584 (120Hz)	46.7	4.76	3880	396	2 -	6100	- AV	- 6	D-29
21.9	219	438 (120Hz)	62.2	6.34	2780	283	2 -	6090SK	- AV	- 8 *1	D-28
21.9	219	438 (120Hz)	62.2	6.34	4330	441	2 -	6100	- AV	- 8	D-29
17.5	175	350 (120Hz)	77.8	7.93	2900	296	2 -	6095SK	- AV	- 10 *1	D-28
15.9	159	318 (120Hz)	85.5	8.72	4920	501	2 -	6100	- AV	- 11	D-29
13.5	135	270 (120Hz)	101	10.3	5110	521	2 -	6100	- AV	- 13	D-29
11.7	117	234 (120Hz)	117	11.9	5400	550	2 -	6100	- AV	- 15	D-29
10.3	103	206 (120Hz)	132	13.5	5400	550	2 -	6100	- AV	- 17	D-29
8.33	83.3	167 (120Hz)	163	16.6	5400	550	2 -	6105	- AV	- 21	D-29
7.00	70.0	140 (120Hz)	194	19.8	5400	550	2 -	6105	- AV	- 25	D-29
6.03	60.3	121 (120Hz)	226	23.0	5400	550	2 -	6105	- AV	- 29	D-29
5.00	50.0	100 (120Hz)	272	27.7	7360	751	2 -	6115	- AV	- 35	D-29
4.07	40.7	81.4 (120Hz)	334	34.1	7610	776	2 -	6115	- AV	- 43	D-29
3.43	34.3	68.6 (120Hz)	397	40.4	9810	1000	2 -	6120	- AV	- 51	D-29
2.97	29.7	59.4 (120Hz)	459	46.8	9810	1000	2 -	6125	- AV	- 59	D-29
2.46	24.6	49.2 (120Hz)	552	56.3	12900	1320	2 -	6130	- AV	- 71	D-30
2.01	20.1	40.2 (120Hz)	677	69.0	13900	1420	2 -	6135	- AV	- 87	D-30
1.68	16.8	33.7 (120Hz)	766	78.1	14700	1500	2 -	6135DC	- AV	- 104	D-34
1.45	14.5	28.9 (120Hz)	891	90.9	14700	1500	2 -	6135DC	- AV	- 121	D-34
1.22	12.2	24.5 (120Hz)	1050	107	15900	1620	2 -	6145DC	- AV	- 143	D-34
1.06	10.6	21.2 (120Hz)	1220	124	16000	1630	2 -	6145DC	- AV	- 165	D-34
0.897	8.97	17.9 (120Hz)	1440	146	22100	2250	2 -	6165DB	- AV	- 195	D-34
0.758	7.58	15.2 (120Hz)	1700	173	22100	2250	2 -	6165DB	- AV	- 231	D-34
0.641	6.41	12.8 (120Hz)	2010	205	22100	2250	2 -	6165DB	- AV	- 273	D-34
0.549	5.49	11.0 (120Hz)	2350	240	29500	3010	2 -	6175DB	- AV	- 319	D-34
0.464	4.64	9.3 (120Hz)	2780	283	29500	3010	2 -	6175DB	- AV	- 377	D-34
0.370	3.70	7.4 (120Hz)	3480	355	41700	4250	2 -	6185DA	- AV	- 473	D-34
0.313	3.13	6.3 (120Hz)	4120	420	41700	4250	2 -	6185DA	- AV	- 559	D-34
0.270	2.70	5.4 (120Hz)	4780	487	41700	4250	2 -	6185DA	- AV	- 649	D-34
0.239	2.39	4.8 (120Hz)	5390	549	59000	6010	2 -	6195DA	- AV	- 731	D-35
0.208	2.08	4.2 (120Hz)	6200	632	59000	6010	2 -	6195DA	- AV	- 841	D-35
0.174	1.74	3.5 (120Hz)	7390	753	58300	5940	2 -	6195DA	- AV	- 1003	D-35
0.118	1.18	2.4 (120Hz)	10900	1110	104000	10600	2 -	6215DA	- AV	- 1479	D-36
0.095	0.95	1.9 (120Hz)	13600	1390	145000	14800	2 -	6225DA	- AV	- 1849	D-36
0.085	0.85	1.7 (120Hz)	15200	1550	145000	14800	2 -	6225DA	- AV	- 2065	D-36

- Note: 1. Allowable radial load Pro is the value at the midpoint of the output shaft.
 2. Lubrication method is different for each model. Refer to "Lubrication" section in page F-4~F-5 for details.
 3. "6" at the end of "input capacity symbol" indicates models with 6P motor. Other models come with 4P motor.
 4. Refer to page D-9 "Precautions for Inverter Driving" when operating beyond 6~60 Hz.

Selection Tables
1.5 kW
GEARMOTOR
FOR INVERTERS

Selection Tables Gearmotors (AF Motor for Inverters)

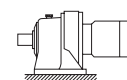

CHHM/CNHM

2.2 kW	AF Motor for Inverters	
	P	4
	Motor Speed n ₁ r/min	1750(60Hz)

Output Speed n ₂ r/min			Output Torque (60Hz) Tout		Allowable Radial Load (60Hz) Pro		Model				Dim. Page			
6Hz	60Hz	Allowable MAX Speed (Horizontal)	N·m	kgf·m	N	kgf	Input Capacity - Symbol	Frame Size -	Suffix -	Reduction Ratio	CNHM CHHM			
70.0	700	1400 (120Hz)	28.5	2.91	1970	201	3	-	6100SK	-	AV	-	2.5 *1	D-28
58.3	583	1167 (120Hz)	34.2	3.49	2040	208	3	-	6100SK	-	AV	-	3 *1	D-28
43.8	438	875 (120Hz)	45.6	4.65	2240	228	3	-	6100SK	-	AV	-	4 *1	D-28
35.0	350	700 (120Hz)	57.0	5.81	2330	238	3	-	6100SK	-	AV	-	5 *1	D-28
29.2	292	584 (120Hz)	68.4	6.98	2370	242	3	-	6100SK	-	AV	-	6 *1	D-28
29.2	292	584 (120Hz)	68.4	6.98	4370	445	3	-	6110	-	AV	-	6	D-29
21.9	219	438 (120Hz)	91.2	9.30	2500	255	3	-	6105SK	-	AV	-	8 *1	D-28
21.9	219	438 (120Hz)	91.2	9.30	4870	496	3	-	6110	-	AV	-	8	D-29
17.5	175	350 (120Hz)	114	11.6	2500	263	3	-	6105SK	-	AV	-	10 *1	D-28
15.9	159	318 (120Hz)	125	12.8	5560	567	3	-	6110	-	AV	-	11	D-29
13.5	135	270 (120Hz)	148	15.1	5740	586	3	-	6110	-	AV	-	13	D-29
11.7	117	234 (120Hz)	171	17.4	6120	624	3	-	6110	-	AV	-	15	D-29
10.3	103	206 (120Hz)	194	19.8	6180	630	3	-	6110	-	AV	-	17	D-29
8.33	83.3	167 (120Hz)	240	24.4	6540	667	3	-	6115	-	AV	-	21	D-29
7.00	70.0	140 (120Hz)	285	29.1	6620	675	3	-	6115	-	AV	-	25	D-29
6.03	60.3	121 (120Hz)	331	33.7	6800	693	3	-	6115	-	AV	-	29	D-29
5.00	50.0	100 (120Hz)	399	40.7	8830	900	3	-	6120	-	AV	-	35	D-29
4.07	40.7	81.4 (120Hz)	490	50.0	9380	956	3	-	6125	-	AV	-	43	D-29
3.43	34.3	68.6 (120Hz)	582	59.3	11500	1180	3	-	6135	-	AV	-	51	D-30
2.97	29.7	59.4 (120Hz)	673	68.6	12100	1230	3	-	6135	-	AV	-	59	D-30
2.46	24.6	49.2 (120Hz)	810	82.5	16000	1630	3	-	6145	-	AV	-	71	D-30
2.01	20.1	40.2 (120Hz)	992	101	22100	2250	3	-	6160	-	AV	-	87	D-30
1.68	16.8	33.7 (120Hz)	1120	115	22100	2250	3	-	6160DC	-	AV	-	104	D-35
1.45	14.5	28.9 (120Hz)	1310	133	22100	2250	3	-	6160DC	-	AV	-	121	D-35
1.22	12.2	24.5 (120Hz)	1550	158	22100	2250	3	-	6165DC	-	AV	-	143	D-35
1.06	10.6	21.2 (120Hz)	1780	182	22100	2250	3	-	6165DC	-	AV	-	165	D-35
0.897	8.97	17.9 (120Hz)	2100	214	22100	2250	3	-	6165DC	-	AV	-	195	D-35
0.758	7.58	15.2 (120Hz)	2500	254	29500	3010	3	-	6175DC	-	AV	-	231	D-35
0.641	6.41	12.8 (120Hz)	2950	301	29500	3010	3	-	6175DC	-	AV	-	273	D-35
0.549	5.49	11.0 (120Hz)	3450	351	41700	4250	3	-	6185DB	-	AV	-	319	D-35
0.464	4.64	9.3 (120Hz)	4070	415	41700	4250	3	-	6185DB	-	AV	-	377	D-35
0.370	3.70	7.4 (120Hz)	5110	521	59000	6010	3	-	6195DA	-	AV	-	473	D-35
0.313	3.13	6.3 (120Hz)	6040	616	59000	6010	3	-	6195DA	-	AV	-	559	D-35
0.270	2.70	5.4 (120Hz)	7010	715	58400	5950	3	-	6195DA	-	AV	-	649	D-35
0.239	2.39	4.8 (120Hz)	7900	805	59000	6010	3	-	6195DA	-	AV	-	731	D-35
0.208	2.08	4.2 (120Hz)	9090	926	84100	8570	3	-	6205DA	-	AV	-	841	D-36
0.174	1.74	3.5 (120Hz)	10800	1100	104000	10600	3	-	6215DA	-	AV	-	1003	D-36
0.140	1.40	2.8 (120Hz)	13500	1370	145000	14800	3	-	6225DA	-	AV	-	1247	D-36
0.118	1.18	2.4 (120Hz)	16000	1630	179000	18200	3	-	6235DA	-	AV	-	1479	D-37
0.095	0.95	1.9 (120Hz)	20000	2040	179000	18200	3	-	6235DA	-	AV	-	1849	D-37
0.085	0.85	1.7 (120Hz)	22300	2270	208000	21200	3	-	6245DA	-	AV	-	2065	D-37

- **1" indicate models with reduction ratios equal to nominal ratio. Refer to Table A-3 "6000 SK Series (Actual Reduction Ratio)" on page A-4 for actual reduction ratio. Indicated reduction ratio is the same as actual reduction ratio for other models.
- **2" indicate models requiring increased capacity for inverters, for certain operation conditions (ambient temperature, load condition, etc.).
- Consult us for vertical types. Lubrication oil and system requires contemplation.

Selection Tables Gearmotors (AF Motor for Inverters)

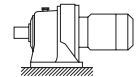

CHHM/CNHM

3.7 kW	AF Motor for Inverters	
	P	4
	Motor Speed n ₁	r/min 1750(60Hz)

Output Speed n ₂ r/min			Output Torque (60Hz) Tout		Allowable Radial Load (60Hz) Pro		Model				Dim. Page
6Hz	60Hz	Allowable MAX Speed (Horizontal)	N·m	kgf·m	N	kgf	Input Capacity Symbol	Frame Size	Suffix	Reduction Ratio	CNHM CHHM
70.0	700	1400 (120Hz)	48.0	4.89	2500	255	5 -	6110SK	- AV	- 2.5 *1	D-28
58.3	583	1167 (120Hz)	57.5	5.87	2650	275	5 -	6110SK	- AV	- 3 *1	D-28
43.8	438	875 (120Hz)	76.7	7.82	2820	287	5 -	6110SK	- AV	- 4 *1	D-28
35.0	350	700 (120Hz)	95.9	9.78	2930	299	5 -	6110SK	- AV	- 5 *1	D-28
29.2	292	584 (120Hz)	115	11.7	3060	312	5 -	6110SK	- AV	- 6 *1	D-28
29.2	292	389 (80Hz)	115	11.7	4910	500	5 -	6120	- AV	- 6	D-29
21.9	219	438 (120Hz)	153	15.6	3190	325	5 -	6110SK	- AV	- 8 *1	D-28
21.9	219	438 (120Hz)	153	15.6	5470	557	5 -	6120	- AV	- 8	D-29
17.5	175	350 (120Hz)	192	19.6	3330	339	5 -	6115SK	- AV	- 10 *1	D-28
15.9	159	318 (120Hz)	211	21.5	6200	632	5 -	6120	- AV	- 11	D-29
13.5	135	270 (120Hz)	249	25.4	6400	652	5 -	6120	- AV	- 13	D-29
11.7	117	234 (120Hz)	288	29.3	6860	699	5 -	6120	- AV	- 15	D-29
10.3	103	206 (120Hz)	326	33.2	6920	705	5 -	6125	- AV	- 17	D-29
8.33	83.3	167 (120Hz)	403	41.1	7570	772	5 -	6125	- AV	- 21	D-29
7.00	70.0	140 (120Hz)	480	48.9	7900	806	5 -	6125	- AV	- 25	D-29
6.03	60.3	121 (120Hz)	556	56.7	9700	989	5 -	6130	- AV	- 29	D-30
5.00	50.0	100 (120Hz)	671	68.4	10200	1040	5 -	6135	- AV	- 35	D-30
4.07	40.7	81.4 (120Hz)	825	84.1	15800	1610	5 -	6145	- AV	- 43	D-30
3.43	34.3	68.6 (120Hz)	978	99.7	16000	1630	5 -	6145	- AV	- 51	D-30
2.97	29.7	59.4 (120Hz)	1130	115	22100	2250	5 -	6160	- AV	- 59	D-30
2.46	24.6	34.0 (83Hz)	1360	139	21900	2240	5 -	6165	- AV	- 71	D-30
2.01	20.1	27.8 (83Hz)	1670	170	21800	2220	5 -	6165	- AV	- 87	D-30
1.68	16.8	33.7 (120Hz)	1890	193	22100	2250	5 -	6165DC	- AV	- 104	D-35
1.45	14.5	28.9 (120Hz)	2200	224	29500	3010	5 -	6175DC	- AV	- 121	D-35
1.22	12.2	24.5 (120Hz)	2600	265	29500	3010	5 -	6175DC	- AV	- 143	D-35
1.06	10.6	21.2 (120Hz)	3000	306	29500	3010	5 -	6175DC	- AV	- 165	D-35
0.897	8.97	17.9 (120Hz)	3540	361	41700	4250	5 -	6185DB	- AV	- 195	D-35
0.758	7.58	15.2 (120Hz)	4200	428	41700	4250	5 -	6185DB	- AV	- 231	D-35
0.641	6.41	12.8 (120Hz)	4960	506	41700	4250	5 -	6185DB	- AV	- 273	D-35
0.549	5.49	11.0 (120Hz)	5800	591	59000	6010	5 -	6195DA	- AV	- 319	D-35
0.464	4.64	9.3 (120Hz)	6850	698	59000	6010	5 -	6195DA	- AV	- 377	D-35
0.370	3.70	7.4 (120Hz)	8600	876	104000	10600	5 -	6215DA	- AV	- 473	D-36
0.313	3.13	6.3 (120Hz)	10200	1040	104000	10600	5 -	6215DA	- AV	- 559	D-36
0.270	2.70	5.4 (120Hz)	11800	1200	104000	10600	5 -	6215DA	- AV	- 649	D-36
0.239	2.39	4.8 (120Hz)	13300	1350	145000	14800	5 -	6225DA	- AV	- 731	D-36
0.208	2.08	4.2 (120Hz)	15300	1560	179000	18200	5 -	6235DA	- AV	- 841	D-37
0.174	1.74	3.5 (120Hz)	18200	1860	179000	18200	5 -	6235DA	- AV	- 1003	D-37
0.140	1.40	2.8 (120Hz)	22700	2310	208000	21200	5 -	6245DA	- AV	- 1247	D-37
0.118	1.18	1.6 (83Hz)	26900	2740	258000	26300	5 -	6255DA	- AV	- 1479 *2	D-37
0.095	0.95	1.3 (83Hz)	33600	3430	258000	26300	5 -	6255DA	- AV	- 1849 *2	D-37

- Note: 1. Allowable radial load Pro is the value at the midpoint of the output shaft.
 2. Lubrication method is different for each model. Refer to "Lubrication" section in page F-4~F-5 for details.
 3. "6" at the end of "input capacity symbol" indicates models with 6P motor. Other models come with 4P motor.
 4. Refer to page D-9 "Precautions for Inverter Driving" when operating beyond 6~60 Hz.

SELECTION TABLES
GEARMOTOR
FOR INVERTERS
3.7 kW

Selection Tables Gearmotors (AF Motor for Inverters)

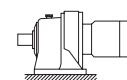

CHHM

5.5 kW	AF Motor for Inverters	
	P	4
	Motor Speed n ₁ r/min	1750(60Hz)

Output Speed n ₂ r/min			Output Torque (60Hz) Tout N·m kgf·m	Allowable Radial Load (60Hz) Pro N kgf		Model				Dim. Page	
6Hz	60Hz	Allowable MAX Speed (Horizontal)				Input Capacity - Symbol	Frame Size	Suffix	Reduction Ratio	CHHM	
29.2	292	584 (120Hz)	171	17.4	5710	582	8 -	6130	- AV -	6	D-30
21.9	219	438 (120Hz)	228	23.3	6360	648	8 -	6130	- AV -	8	D-30
15.9	159	318 (120Hz)	314	32.0	7240	739	8 -	6130	- AV -	11	D-30
13.5	135	270 (120Hz)	371	37.8	7530	768	8 -	6130	- AV -	13	D-30
11.7	117	234 (120Hz)	428	43.6	7680	783	8 -	6130	- AV -	15	D-30
10.3	103	206 (120Hz)	485	49.4	8230	839	8 -	6135	- AV -	17	D-30
8.33	83.3	167 (120Hz)	599	61.0	8760	893	8 -	6135	- AV -	21	D-30
7.00	70.0	140 (120Hz)	713	72.7	9070	925	8 -	6135	- AV -	25	D-30
6.03	60.3	121 (120Hz)	827	84.3	14100	1430	8 -	6140	- AV -	29	D-30
5.00	50.0	100 (120Hz)	998	102	15000	1530	8 -	6145	- AV -	35	D-30
4.07	40.7	56.3 (83Hz)	1230	125	18900	1930	8 -	6160	- AV -	43	D-30
3.43	34.3	47.4 (83Hz)	1450	148	19600	2000	8 -	6165	- AV -	51	D-30
2.97	29.7	41.1 (83Hz)	1680	171	21700	2220	8 -	6165	- AV -	59	D-30
2.46	24.6	34.0 (83Hz)	2020	206	24700	2520	8 -	6175	- AV -	71	D-31
2.01	20.1	27.8 (83Hz)	2480	253	26400	2690	8 -	6175	- AV -	87	D-31
1.68	16.8	33.7 (120Hz)	2810	286	37700	3840	8 -	6180DB	- AV -	104	D-35
1.45	14.5	28.9 (120Hz)	3270	333	40000	4070	8 -	6185DB	- AV -	121	D-35
1.22	12.2	24.5 (120Hz)	3860	394	41700	4250	8 -	6185DB	- AV -	143	D-35
1.06	10.6	21.2 (120Hz)	4460	454	41700	4250	8 -	6185DB	- AV -	165	D-35
0.897	8.97	17.9 (120Hz)	5270	537	58300	5940	8 -	6195DB	- AV -	195	D-35
0.758	7.58	15.2 (120Hz)	6240	636	59000	6010	8 -	6195DB	- AV -	231	D-35
0.641	6.41	12.8 (120Hz)	7370	752	59000	6010	8 -	6195DB	- AV -	273	D-35
0.549	5.49	11.0 (120Hz)	8620	878	84100	8570	8 -	6205DB	- AV -	319	D-36
0.464	4.64	9.3 (120Hz)	10200	1040	104000	10600	8 -	6215DA	- AV -	377	D-36
0.370	3.70	7.4 (120Hz)	12800	1300	145000	14800	8 -	6225DA	- AV -	473	D-36
0.313	3.13	6.3 (120Hz)	15100	1540	145000	14800	8 -	6225DA	- AV -	559	D-36
0.270	2.70	5.4 (120Hz)	17500	1790	179000	18200	8 -	6235DA	- AV -	649	D-37
0.239	2.39	4.8 (120Hz)	19700	2010	179000	18200	8 -	6235DA	- AV -	731	D-37
0.208	2.08	4.2 (120Hz)	22700	2320	208000	21200	8 -	6245DA	- AV -	841	D-37
0.174	1.74	2.4 (83Hz)	27100	2760	258000	26300	8 -	6255DA	- AV -	1003 *2	D-37
0.140	1.40	1.9 (83Hz)	33700	3430	258000	26300	8 -	6255DA	- AV -	1247	D-37
0.118	1.18	1.4 (73Hz)	40000	4070	276000	28100	8 -	6265DA	- AV -	1479 *2	D-37

- **1" indicate models with reduction ratios equal to nominal ratio. Refer to Table A-3 "6000 SK Series (Actual Reduction Ratio)" on page A-4 for actual reduction ratio. Indicated reduction ratio is the same as actual reduction ratio for other models.
- **2" indicate models requiring increased capacity for inverters, for certain operation conditions (ambient temperature, load condition, etc.).
- Consult us for vertical types. Lubrication oil and system requires contemplation.

Selection Tables Gearmotors (AF Motor for Inverters)

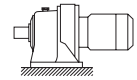

CHHM

7.5 kW	AF Motor for Inverters	
	P	4
	Motor Speed n ₁	r/min
		1750(60Hz)

Output Speed n ₂ r/min			Output Torque (60Hz) Tout		Allowable Radial Load (60Hz) Pro		Model				Dim. Page
6Hz	60Hz	Allowable MAX Speed (Horizontal)	N·m	kgf·m	N	kgf	Input Capacity - Symbol	Frame Size	Suffix	Reduction Ratio	CHHM
29.2	292	584 (120Hz)	233	23.8	5650	576	10 -	6130	- AV	- 6	D-30
21.9	219	438 (120Hz)	311	31.7	6290	641	10 -	6130	- AV	- 8	D-30
15.9	159	318 (120Hz)	428	43.6	7150	729	10 -	6130	- AV	- 11	D-30
13.5	135	270 (120Hz)	505	51.5	7430	758	10 -	6130	- AV	- 13	D-30
11.7	117	234 (120Hz)	583	59.5	7570	771	10 -	6135	- AV	- 15	D-30
10.3	103	206 (120Hz)	661	67.4	8100	826	10 -	6135	- AV	- 17	D-30
8.33	83.3	167 (120Hz)	817	83.2	13100	1330	10 -	6145	- AV	- 21	D-30
7.00	70.0	140 (120Hz)	972	99.1	13700	1390	10 -	6145	- AV	- 25	D-30
6.03	60.3	121 (120Hz)	1130	115	14000	1420	10 -	6145	- AV	- 29	D-30
5.00	50.0	100 (120Hz)	1360	139	17500	1790	10 -	6165	- AV	- 35	D-30
4.07	40.7	56.3 (83Hz)	1670	170	18600	1900	10 -	6165	- AV	- 43	D-30
3.43	34.3	47.4 (83Hz)	1980	202	22100	2250	10 -	6170	- AV	- 51	D-31
2.97	29.7	41.1 (83Hz)	2290	234	23100	2360	10 -	6175	- AV	- 59	D-31
2.46	24.6	34.0 (83Hz)	2760	281	33100	3380	10 -	6180	- AV	- 71	D-31
2.01	20.1	27.8 (83Hz)	3380	345	35600	3620	10 -	6185	- AV	- 87	D-31
1.68	16.8	33.7 (120Hz)	3830	391	37300	3800	10 -	6185DB	- AV	- 104	D-35
1.45	14.5	28.9 (120Hz)	4460	454	40000	4070	10 -	6185DB	- AV	- 121	D-35
1.22	12.2	24.5 (120Hz)	5270	537	57900	5900	10 -	6195DB	- AV	- 143	D-35
1.06	10.6	21.2 (120Hz)	6080	620	58300	5940	10 -	6195DB	- AV	- 165	D-35
0.897	8.97	17.9 (120Hz)	7180	732	58300	5940	10 -	6195DB	- AV	- 195	D-35
0.758	7.58	15.2 (120Hz)	8510	867	84100	8570	10 -	6205DB	- AV	- 231	D-36
0.641	6.41	12.8 (120Hz)	10100	1030	104000	10600	10 -	6215DA	- AV	- 273	D-36
0.549	5.49	11.0 (120Hz)	11800	1200	104000	10600	10 -	6215DA	- AV	- 319	D-36
0.464	4.64	9.3 (120Hz)	13900	1420	145000	14800	10 -	6225DA	- AV	- 377	D-36
0.370	3.70	7.4 (120Hz)	17400	1780	179000	18200	10 -	6235DA	- AV	- 473	D-37
0.313	3.13	6.3 (120Hz)	20600	2100	179000	18200	10 -	6235DA	- AV	- 559	D-37
0.270	2.70	5.4 (120Hz)	23900	2440	208000	21200	10 -	6245DA	- AV	- 649	D-37
0.239	2.39	3.3 (83Hz)	26900	2740	258000	26300	10 -	6255DA	- AV	- 731 *2	D-37
0.208	2.08	2.9 (83Hz)	31000	3160	258000	26300	10 -	6255DA	- AV	- 841	D-37
0.174	1.74	2.1 (73Hz)	36900	3770	276000	28100	10 -	6265DA	- AV	- 1003	D-37
0.140	1.40	1.7 (73Hz)	45900	4680	276000	28100	10 -	6265DA	- AV	- 1247 *2	D-37
0.118	1.18	1.4 (73Hz)	54500	5550	248000	25300	10 -	6275DA	- AV	- 1479	D-37
0.095	0.95	1.2 (73Hz)	68100	6940	248000	25300	10 -	6275DA	- AV	- 1849	D-37

SELECTION TABLES
GEARMOTOR FOR INVERTERS
7.5 kW

- Note: 1. Allowable radial load Pro is the value at the midpoint of the output shaft.
 2. Lubrication method is different for each model. Refer to "Lubrication" section in page F-4~F-5 for details.
 3. "6" at the end of "input capacity symbol" indicates models with 6P motor. Other models come with 4P motor.
 4. Refer to page D-9 "Precautions for Inverter Driving" when operating beyond 6~60 Hz.

Selection Tables Gearmotors (AF Motor for Inverters)

11 kW	AF Motor for Inverters	
	P	4
	Motor Speed n ₁	r/min 1750(60Hz)

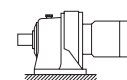

CHHM

Output Speed n ₂ r/min			Output Torque (60Hz) Tout	Allowable Radial Load (60Hz) Pro		Model				Dim. Page	
6Hz	60Hz	Allowable MAX Speed (Horizontal)		N·m	kgf·m	N	kgf	Input Capacity - Symbol	Frame Size -	Suffix -	Reduction Ratio -
29.2	292	584 (120Hz)	342	34.9	5540	564	15 -	6135	- AV	- 6	D-30
21.9	219	438 (120Hz)	456	46.5	6150	627	15 -	6135	- AV	- 8	D-30
15.9	159	318 (120Hz)	627	63.9	6980	712	15 -	6135	- AV	- 11	D-30
13.5	135	270 (120Hz)	741	75.6	11100	1140	15 -	6140	- AV	- 13	D-30
11.7	117	234 (120Hz)	855	87.2	11600	1190	15 -	6140	- AV	- 15	D-30
10.3	103	206 (120Hz)	969	98.8	12100	1240	15 -	6145	- AV	- 17	D-30
8.33	83.3	115 (83Hz)	1200	122	15000	1530	15 -	6160	- AV	- 21	D-30
7.00	70.0	96.8 (83Hz)	1430	145	15700	1600	15 -	6165	- AV	- 25	D-30
6.03	60.3	83.4 (83Hz)	1650	169	16300	1660	15 -	6165	- AV	- 29	D-30
5.00	50.0	69.2 (83Hz)	2000	203	19700	2010	15 -	6170	- AV	- 35	D-31
4.07	40.7	56.3 (83Hz)	2450	250	20900	2130	15 -	6175	- AV	- 43	D-31
3.43	34.3	47.4 (83Hz)	2910	296	29600	3010	15 -	6180	- AV	- 51	D-31
2.97	29.7	41.1 (83Hz)	3360	343	30900	3150	15 -	6185	- AV	- 59	D-31
2.46	24.6	29.9 (73Hz)	4050	413	46300	4720	15 -	6190	- AV	- 71	D-31
2.01	20.1	24.5 (73Hz)	4960	506	49700	5070	15 -	6195	- AV	- 87	D-31
1.68	16.8	33.7 (120Hz)	5620	573	51800	5280	15 -	6195DB	- AV	- 104	D-35
1.45	14.5	28.9 (120Hz)	6540	666	55500	5660	15 -	6195DB	- AV	- 121	D-35
1.06	10.6	21.2 (120Hz)	8910	909	84100	8570	15 -	6205DB	- AV	- 165	D-36
0.897	8.97	17.9 (120Hz)	10500	1070	104000	10600	15 -	6215DA	- AV	- 195	D-36
0.758	7.58	15.2 (120Hz)	12500	1270	104000	10600	15 -	6215DA	- AV	- 231	D-36
0.641	6.41	12.8 (120Hz)	14800	1510	137000	13900	15 -	6225DA	- AV	- 273	D-36
0.549	5.49	11.0 (120Hz)	17200	1760	177000	18100	15 -	6235DA	- AV	- 319	D-37
0.464	4.64	9.3 (120Hz)	20400	2080	208000	21200	15 -	6245DA	- AV	- 377 *2	D-37
0.370	3.70	7.4 (120Hz)	25600	2600	208000	21200	15 -	6245DA	- AV	- 473	D-37
0.313	3.13	3.8 (73Hz)	30200	3080	258000	26300	15 -	6255DA	- AV	- 559 *2	D-37
0.270	2.70	3.3 (73Hz)	35100	3570	276000	28100	15 -	6265DA	- AV	- 649 *2	D-37
0.239	2.39	2.9 (73Hz)	39500	4030	276000	28100	15 -	6265DA	- AV	- 731 *2	D-37
0.208	2.08	2.5 (73Hz)	45400	4630	276000	28100	15 -	6265DA	- AV	- 841 *2	D-37
0.174	1.74	2.1 (73Hz)	54200	5520	248000	25300	15 -	6275DA	- AV	- 1003 *2	D-37
0.140	1.40	1.7 (73Hz)	67400	6870	248000	25300	15 -	6275DA	- AV	- 1247 *2	D-37

- **1" indicate models with reduction ratios equal to nominal ratio. Refer to Table A-3 "6000 SK Series (Actual Reduction Ratio)" on page A-4 for actual reduction ratio. Indicated reduction ratio is the same as actual reduction ratio for other models.
- **2" indicate models requiring increased capacity for inverters, for certain operation conditions (ambient temperature, load condition, etc.).
- Consult us for vertical types. Lubrication oil and system requires contemplation.

Selection Tables Gearmotors (AF Motor for Inverters)

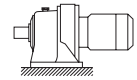

CHHM

15 kW	AF Motor for Inverters	
	P	4
	Motor Speed n_1	r/min 1750(60Hz)

Output Speed n_2 /min			Output Torque (60Hz) Tout		Allowable Radial Load (60Hz) Pro		Model				Dim. Page
6Hz	60Hz	Allowable MAX Speed (Horizontal)	N·m	kgf·m	N	kgf	Input Capacity - Symbol	Frame Size	Suffix	Reduction Ratio	CNHM
29.2	292	355 (73Hz)	467	47.6	9670	986	20 -	6160	- AV	- 6	D-30
21.9	219	518 (120Hz)	622	63.4	10800	1100	20 -	6160	- AV	- 8	D-30
15.9	159	318 (120Hz)	855	87.2	12200	1240	20 -	6160	- AV	- 11	D-30
13.5	135	270 (120Hz)	1010	103	12700	1300	20 -	6165	- AV	- 13	D-30
11.7	117	142 (73Hz)	1170	119	13500	1370	20 -	6165	- AV	- 15	D-30
10.3	103	142 (83Hz)	1320	135	13900	1410	20 -	6165	- AV	- 17	D-30
8.33	83.3	115 (83Hz)	1630	166	14800	1510	20 -	6165	- AV	- 21	D-30
7.00	70.0	85.2 (73Hz)	1940	198	17500	1780	20 -	6170	- AV	- 25	D-31
6.03	60.3	73.4 (73Hz)	2260	230	18400	1870	20 -	6175	- AV	- 29	D-31
5.00	50.0	69.2 (83Hz)	2720	277	26500	2700	20 -	6180	- AV	- 35	D-31
4.07	40.7	56.3 (83Hz)	3340	341	28300	2880	20 -	6185	- AV	- 43	D-31
3.43	34.3	41.7 (73Hz)	3970	404	29200	2980	20 -	6185	- AV	- 51	D-31
2.97	29.7	36.1 (73Hz)	4590	468	43400	4430	20 -	6195	- AV	- 59	D-31
2.46	24.6	29.9 (73Hz)	5520	563	45900	4680	20 -	6195	- AV	- 71	D-31
2.01	20.1	24.5 (73Hz)	6770	690	84100	8570	20 -	6205	- AV	- 87 *2	D-32
1.45	14.5	28.9 (120Hz)	8910	909	101000	10300	20 -	6215DB	- AV	- 121	D-36
1.06	10.6	21.2 (120Hz)	12200	1240	104000	10600	20 -	6215DB	- AV	- 165	D-36
0.897	8.97	17.9 (120Hz)	14400	1460	122000	12400	20 -	6225DB	- AV	- 195	D-36
0.758	7.58	15.2 (120Hz)	17000	1730	162000	16500	20 -	6235DA	- AV	- 231	D-37
0.641	6.41	12.8 (120Hz)	20100	2050	188000	19200	20 -	6245DA	- AV	- 273	D-37
0.549	5.49	10.1 (110Hz)	23500	2400	197000	20100	20 -	6245DA	- AV	- 319	D-37
0.464	4.64	5.7 (73Hz)	27800	2830	255000	26000	20 -	6255DA	- AV	- 377	D-37
0.370	3.70	4.5 (73Hz)	34800	3550	276000	28100	20 -	6265DA	- AV	- 473 *2	D-37
0.313	3.13	3.8 (73Hz)	41200	4200	276000	28100	20 -	6265DA	- AV	- 559 *2	D-37
0.270	2.70	3.3 (73Hz)	47800	4870	248000	25300	20 -	6275DA	- AV	- 649 *2	D-37
0.239	2.39	2.9 (73Hz)	53900	5490	248000	25300	20 -	6275DA	- AV	- 731 *2	D-37
0.208	2.08	2.5 (73Hz)	62000	6320	248000	25300	20 -	6275DA	- AV	- 841	D-37

SELECTION TABLES
GEARMOTOR FOR INVERTERS
15 kW

- Notes: 1. Allowable radial load Pro is the value at the midpoint of the output shaft.
 2. Lubrication method is different for each model. Refer to "Lubrication" section in page F-4~F-5 for details.
 3. "6" at the end of "input capacity symbol" indicates models with 6P motor. Other models come with 4P motor.
 4. Refer to page D-9 "Precautions for Inverter Driving" when operating beyond 6~60 Hz.

Selection Tables 600SK Series•Reducer

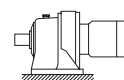

CHHM

18.5 kW	AF Motor for Inverters	
	P	4
	Motor Speed n ₁	r/min 1750(60Hz)

Output Speed n ₂ r/min			Output Torque (60Hz) Tout		Allowable Radial Load (60Hz) Pro		Model				Dim. Page
6Hz	60Hz	Allowable MAX Speed (Horizontal)	N·m	kgf·m	N	kgf	Input Capacity - Symbol	Frame Size	Suffix	Reduction Ratio	CNHM
29.2	292	292 (60Hz)	575	58.7	10900	1110	25 -	6175	- AV	- 6	D-31
21.9	219	219 (60Hz)	767	78.2	12000	1220	25 -	6175	- AV	- 8	D-31
15.9	159	193 (73Hz)	1060	108	13800	1410	25 -	6175	- AV	- 11	D-31
13.5	135	164 (73Hz)	1250	127	14300	1460	25 -	6175	- AV	- 13	D-31
11.7	117	142 (73Hz)	1440	147	15000	1530	25 -	6175	- AV	- 15	D-31
10.3	103	125 (73Hz)	1630	166	15600	1590	25 -	6175	- AV	- 17	D-31
8.33	83.3	101 (73Hz)	2010	205	16800	1710	25 -	6175	- AV	- 21	D-31
7.00	70.0	85.1 (73Hz)	2400	244	17300	1760	25 -	6175	- AV	- 25	D-31
6.03	60.3	73.4 (73Hz)	2780	284	24700	2520	25 -	6180	- AV	- 29	D-31
5.00	50.0	60.8 (73Hz)	3360	342	26300	2680	25 -	6185	- AV	- 35	D-31
4.07	40.7	40.7 (60Hz)	4120	420	28000	2850	25 -	6185	- AV	- 43	D-31
3.43	34.3	41.7 (73Hz)	4890	499	41300	4210	25 -	6195	- AV	- 51	D-31
2.97	29.7	36.1 (73Hz)	5660	577	43100	4400	25 -	6195	- AV	- 59	D-31
2.01	20.1	20.1 (60Hz)	8340	851	90600	9240	25 -	6215	- AV	- 87 *2	D-32
1.45	14.5	17.6 (73Hz)	11000	1120	106000	10800	25 -	6225DB	- AV	- 121	D-36
1.06	10.6	12.9 (73Hz)	15000	1530	143000	14500	25 -	6235DB	- AV	- 165 *2	D-37
0.897	8.97	10.9 (73Hz)	17700	1810	150000	15300	25 -	6235DB	- AV	- 195 *2	D-37
0.758	7.58	9.22 (73Hz)	21000	2140	179000	18200	25 -	6245DB	- AV	- 231 *2	D-37
0.641	6.41	7.80 (73Hz)	24800	2530	188000	19200	25 -	6245DB	- AV	- 273	D-37
0.549	5.49	6.7 (73Hz)	29000	2950	242000	24600	25 -	6255DA	- AV	- 319	D-37
0.464	4.64	5.7 (73Hz)	34300	3490	276000	28100	25 -	6265DA	- AV	- 377 *2	D-37
0.370	3.70	4.5 (73Hz)	43000	4380	276000	28100	25 -	6265DA	- AV	- 473 *2	D-37
0.313	3.13	3.8 (73Hz)	50800	5180	248000	25300	25 -	6275DA	- AV	- 559 *2	D-37
0.270	2.70	3.3 (73Hz)	59000	6010	248000	25300	25 -	6275DA	- AV	- 649 *2	D-37
0.239	2.39	2.9 (73Hz)	66400	6770	248000	25300	25 -	6275DA	- AV	- 731 *2	D-37

GEARMOTOR FOR INVERTERS
Selection Tables 18.5 kW

5. "*"1" indicate models with reduction ratios equal to nominal ratio. Refer to Table A-3 "6000 SK Series (Actual Reduction Ratio)" on page A-4 for actual reduction ratio. Indicated reduction ratio is the same as actual reduction ratio for other models.
 6. "*"2" indicate models requiring increased capacity for inverters, for certain operation conditions (ambient temperature, load condition, etc.).
 7. Consult us for vertical types. Lubrication oil and system requires contemplation.

Selection Tables Gearmotors (AF Motor for Inverters)

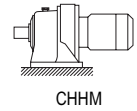

22 kW	AF Motor for Inverters	
	P	4
	Motor Speed n ₁	r/min
		1750(60Hz)

Output Speed n ₂ r/min			Output Torque (60Hz) Tout		Allowable Radial Load (60Hz) Pro		Model				Dim. Page
6Hz	60Hz	Allowable MAX Speed (Horizontal)	N·m	kgf·m	N	kgf	Input Capacity - Symbol	Frame Size	Suffix	Reduction Ratio	CNHM
29.2	292	292 (60Hz)	684	69.8	10800	1100	30 -	6175	- AV	- 6	D-31
21.9	219	219 (60Hz)	912	93.0	11900	1220	30 -	6175	- AV	- 8	D-31
15.9	159	193 (73Hz)	1250	128	13700	1390	30 -	6175	- AV	- 11	D-31
13.5	135	164 (73Hz)	1480	151	14200	1450	30 -	6175	- AV	- 13	D-31
11.7	117	142 (73Hz)	1710	174	14800	1510	30 -	6175	- AV	- 15	D-31
10.3	103	125 (73Hz)	1940	198	15400	1570	30 -	6175	- AV	- 17	D-31
8.33	83.3	101 (73Hz)	2400	244	16600	1690	30 -	6175	- AV	- 21	D-31
7.00	70.0	85.2 (73Hz)	2850	291	23500	2400	30 -	6180	- AV	- 25	D-31
6.03	60.3	73.4 (73Hz)	3310	337	24500	2500	30 -	6185	- AV	- 29	D-31
5.00	50.0	60.8 (73Hz)	3990	407	26000	2650	30 -	6185	- AV	- 35	D-31
4.07	40.7	40.7 (60Hz)	4900	500	39400	4020	30 -	6195	- AV	- 43	D-31
2.97	29.7	29.7 (60Hz)	6730	686	79200	8070	30 -	6205	- AV	- 59 *2	D-32
2.01	20.1	20.1 (60Hz)	9920	1010	95700	9760	30 -	6225	- AV	- 87 *2	D-32
1.45	14.5	17.6 (73Hz)	13100	1330	106000	10800	30 -	6225DB	- AV	- 121	D-36
1.06	10.6	12.9 (73Hz)	17800	1820	143000	14500	30 -	6235DB	- AV	- 165 *2	D-37
0.897	8.97	10.9 (73Hz)	21100	2150	167000	17000	30 -	6245DB	- AV	- 195 *2	D-37
0.758	7.58	9.22 (73Hz)	25000	2540	179000	18200	30 -	6245DB	- AV	- 231 *2	D-37
0.641	6.41	7.80 (73Hz)	29500	3010	229000	23400	30 -	6255DA	- AV	- 273	D-37
0.549	5.49	6.7 (73Hz)	34500	3510	276000	28100	30 -	6265DA	- AV	- 319 *2	D-37
0.464	4.64	5.7 (73Hz)	40700	4150	276000	28100	30 -	6265DA	- AV	- 377 *2	D-37
0.370	3.70	4.5 (73Hz)	51100	5210	248000	25300	30 -	6275DA	- AV	- 473 *2	D-37
0.313	3.13	3.8 (73Hz)	60400	6160	248000	25300	30 -	6275DA	- AV	- 559 *2	D-37

GEARMOTOR FOR INVERTERS
Selection Tables 22 kW

- Note: 1. Allowable radial load Pro is the value at the midpoint of the output shaft.
 2. Lubrication method is different for each model. Refer to "Lubrication" section in page F-4~F-5 for details.
 3. "6" at the end of "input capacity symbol" indicates models with 6P motor. Other models come with 4P motor.
 4. Refer to page D-9 "Precautions for Inverter Driving" when operating beyond 6~60 Hz.

Selection Tables Gearmotors (AF Motor for Inverters)

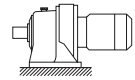

CHHM

30 kW	AF Motor for Inverters		
	P	4	6
	Motor Speed n ₁ r/min	1750(60Hz)	1165(60Hz)

Output Speed n ₂ r/min			Output Torque (60Hz) Tout		Allowable Radial Load (60Hz) Pro		Model				Dim. Page	
6Hz	60Hz	Allowable MAX Speed (Horizontal)	N·m	kgf·m	N	kgf	Input Capacity - Symbol	Frame Size	Suffix	Reduction Ratio	CHHM	
15.9	159	193 (73Hz)	1710	174	18200	1850	40	-	6185	- AV	- 11	D-31
13.5	135	164 (73Hz)	2020	206	18800	1920	40	-	6185	- AV	- 13	D-31
11.7	117	142 (73Hz)	2330	238	19800	2020	40	-	6185	- AV	- 15	D-31
10.3	103	125 (73Hz)	2640	270	20800	2120	40	-	6185	- AV	- 17	D-31
8.33	83.3	83.3 (60Hz)	3270	333	22400	2280	40	-	6185	- AV	- 21	D-31
7.00	70.0	70.0 (60Hz)	3890	396	23100	2360	40	-	6185	- AV	- 25	D-31
6.03	60.3	60.3 (60Hz)	4510	460	34500	3520	40	-	6195	- AV	- 29	D-31
5.55	55.5	55.5 (60Hz)	4910	500	35800	3650	406	-	6190	- AV	- 21	D-31
5.00	50.0	50.0 (60Hz)	5440	555	36300	3700	40	-	6195	- AV	- 35	D-31
4.07	40.7	40.7 (60Hz)	6690	682	72600	7400	40	-	6205	- AV	- 43 *2	D-32
2.97	29.7	29.7 (60Hz)	9180	935	80300	8180	40	-	6215	- AV	- 59 *2	D-32
2.71	27.1	27.1 (60Hz)	10000	1020	83100	8480	406	-	6215	- AV	- 43 *2	D-32
1.97	19.7	19.7 (60Hz)	13800	1410	119000	12200	406	-	6235	- AV	- 59 *2	D-32
1.45	14.5	17.6 (73Hz)	17800	1820	133000	13500	40	-	6235DB	- AV	- 121	D-37
1.06	10.6	12.9 (73Hz)	24300	2480	158000	16100	40	-	6245DB	- AV	- 165	D-37
0.897	8.97	10.9 (73Hz)	28700	2930	204000	20800	40	-	6255DB	- AV	- 195 *2	D-37
0.758	7.58	9.22 (73Hz)	34000	3470	265000	27000	40	-	6265DA	- AV	- 231	D-37
0.641	6.41	7.80 (73Hz)	40200	4100	276000	28100	40	-	6265DA	- AV	- 273	D-37
0.549	5.49	6.7 (73Hz)	47000	4790	248000	25300	40	-	6275DA	- AV	- 319	D-37
0.464	4.64	5.7 (73Hz)	55500	5660	248000	25300	40	-	6275DA	- AV	- 377 *2	D-37

Selection Tables
 30 kW
 GEARMOTOR
 FOR INVERTERS

- "*1" indicate models with reduction ratios equal to nominal ratio. Refer to Table A-3 "6000 SK Series (Actual Reduction Ratio)" on page A-4 for actual reduction ratio. Indicated reduction ratio is the same as actual reduction ratio for other models.
- "*2" indicate models requiring increased capacity for inverters, for certain operation conditions (ambient temperature, load condition, etc.).
- Consult us for vertical types. Lubrication oil and system requires contemplation.

Selection Tables Gearmotors (AF Motor for Inverters)

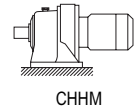

37 kW	AF Motor for Inverters		
	P	4	6
	Motor Speed n ₁ r/min	1750(60Hz)	1165(60Hz)

Output Speed n ₂ r/min			Output Torque (60Hz) Tout		Allowable Radial Load (60Hz) Pro		Model				Dim. Page	
6Hz	60Hz	Allowable MAX Speed (Horizontal)	N·m	kgf·m	N	kgf	Input Capacity Symbol	Frame Size	Suffix	Reduction Ratio	CHHM	
15.9	159	193 (73Hz)	2110	215	25400	2590	50	-	6195	- AV	11	D-31
13.5	135	164 (73Hz)	2490	254	26400	2690	50	-	6195	- AV	13	D-31
11.7	117	142 (73Hz)	2880	293	27700	2820	50	-	6195	- AV	15	D-31
10.3	103	125 (73Hz)	3260	332	29100	2970	50	-	6195	- AV	17	D-31
8.33	83.3	83.3 (60Hz)	4030	411	31300	3190	50	-	6195	- AV	21	D-31
7.77	77.7	77.7 (60Hz)	4320	441	31300	3190	506	-	6190	- AV	15	D-31
7.00	70.0	70.0 (60Hz)	4800	489	32700	3330	50	-	6195	- AV	25	D-31
6.03	60.3	60.3 (60Hz)	5560	567	34200	3490	50	-	6195	- AV	29	D-31
5.55	55.5	55.5 (60Hz)	6050	617	35500	3610	506	-	6195	- AV	21	D-31
4.07	40.7	40.7 (60Hz)	8250	841	73800	7520	50	-	6215	- AV	43	D-32
2.97	29.7	29.7 (60Hz)	11300	1150	84700	8630	50	-	6225	- AV	59	D-32
2.71	27.1	27.1 (60Hz)	12400	1260	87700	8940	506	-	6225	- AV	43 *2	D-32
1.97	19.7	19.7 (60Hz)	17000	1730	133000	13500	506	-	6245	- AV	59 *2	D-32
1.45	14.5	17.6 (73Hz)	22000	2240	180000	18400	50	-	6255DB	- AV	121	D-37
1.06	10.6	12.9 (73Hz)	30000	3060	194000	19800	50	-	6255DB	- AV	165	D-37
0.897	8.97	10.9 (73Hz)	35400	3610	248000	25300	50	-	6265DA	- AV	195	D-37
0.758	7.58	9.22 (73Hz)	42000	4280	265000	27000	50	-	6265DA	- AV	231	D-37
0.549	5.49	6.7 (73Hz)	58000	5910	248000	25300	50	-	6275DA	- AV	319	D-37
0.464	4.64	5.7 (73Hz)	68500	6980	248000	25300	50	-	6275DA	- AV	377 *2	D-37

SELECTION TABLES
GEARMOTOR FOR INVERTERS
37 kW

- Notes:
1. Allowable radial load Pro is the value at the midpoint of the output shaft.
 2. Lubrication method is different for each model. Refer to "Lubrication" section in page F-4~F-5 for details.
 3. "6" at the end of "input capacity symbol" indicates models with 6P motor. Other models come with 4P motor.
 4. Refer to page D-9 "Precautions for Inverter Driving" when operating beyond 6~60 Hz.
 5. "**1" indicate models with reduction ratios equal to nominal ratio. Refer to Table A-3 "6000 SK Series (Actual Reduction Ratio)" on page A-4 for actual reduction ratio. Indicated reduction ratio is the same as actual reduction ratio for other models.
 6. "**2" indicate models requiring increased capacity for inverters, for certain operation conditions (ambient temperature, load condition, etc.).
 7. Consult us for vertical types. Lubrication oil and system requires contemplation.

D CYCLO® GEARMOTORS With AF Motor for Inverters

3. Dimension Tables

GEARMOTOR
FOR INVERTERS

Dimension
Tables

Dimension Tables (Horizontal Direction, Foot Mount)

CHHM^{Note 1} - 607□SK to 611□SK - AV

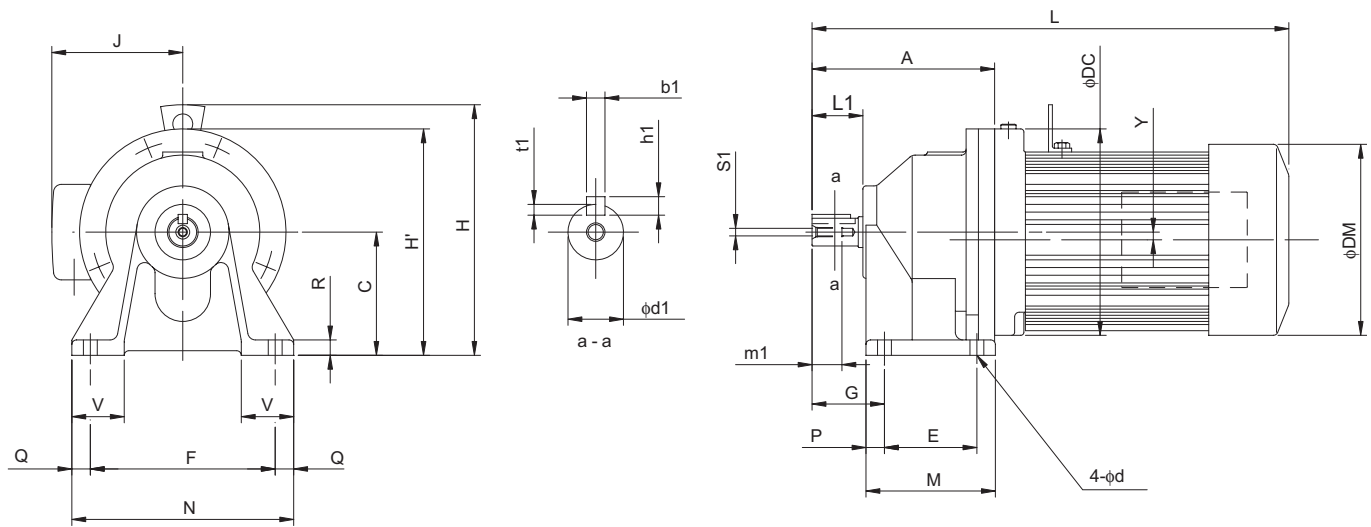

GEARMOTOR FOR INVERTERS
Dimension Tables CHHM

Frame size <small>Note 4</small>	A	C	DC	E	F	G	M	N	P	Q	R	V	Y	d	Output Shaft <small>Note 2, 3, 6</small>						
															d1	L1	b1	h1	t1	S1	m1
607□SK	119	80	134	60	120	47	84	144	12	12	10	34	0	9	18	30	6	6	3.5	M6	16
608□SK	140	90	150	75	120	52	99	144	12	12	13	37	0	9	22	35	6	6	3.5	M6	16
609□SK	166	100	150	90	150	60	135	180	15	15	12	40	0	11	28	35	8	7	4	M8	20
610□SK	170	100	162	90	150	60	135	180	15	15	12	40	0	11	28	35	8	7	4	M8	20
611□SK	182	120	204	90	150	70	135	180	15	15	12	45	3	11	32	45	10	8	5	M8	20

Model <small>Note 4, 5</small>	Motor		Standard						With Brake					
	kW	P	L	H	H'	J	DM	W(kg)	L	H	H'	J	DM	W(kg)
CHHM05 - 607□SK - AV - (B) - Ratio	0.4	4	351	193	-	140	148	13	394	193	-	140	148	15
CHHM1 - 608□SK - AV - (B) - Ratio	0.75	4	410	210	-	145	160	19	472	210	-	145	160	23
CHHM2 - 609□SK - AV - (B) - Ratio	1.5	4	456	226	-	152	173	25	519	226	-	152	173	31
CHHM3 - 610□SK - AV - (B) - Ratio	2.2	4	491	246	-	168	212	38	563	246	-	168	212	49
CHHM5 - 611□SK - AV - (B) - Ratio	3.7	4	539	263	-	168	212	58	611	263	-	168	212	69

- Note: 1. □ indicates motor capacity.
 2. Dimension of shaft end diameter: Dimension tolerance conforms to JIS B 0401-1976 "h6."
 3. Dimension of shaft end key: Dimension tolerance conforms to JIS B 1301-1996 "Parallel Key."

Dimension Tables (Universal Direction, Foot Mount)

CNHM^{Note 1} - 606□ to 612□ - AV

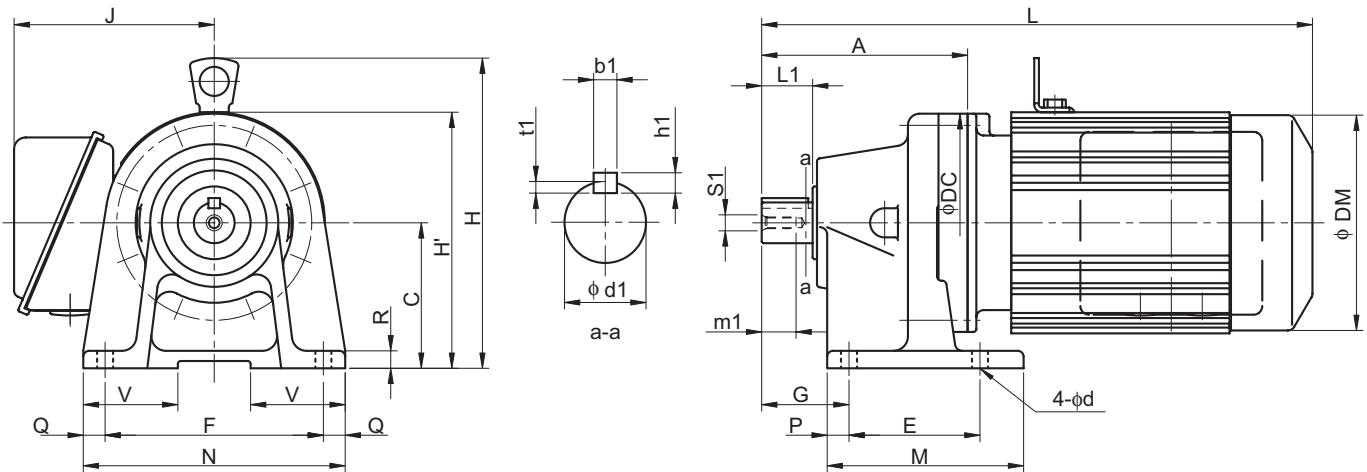

Frame size <small>Note 3</small>	A	C	DC	E	F	G	M	N	O	P	R	V	d	Output Shaft <small>Note 2, 3, 6</small>						
														d1	L1	b1	h1	t1	S1	m1
606□	92	80	110	60	120	41	84	144	12	12	10	35	9	14	25	5	5	3	M5	16
607□	98	80	110	60	120	47	84	144	12	12	10	35	9	18	30	6	6	3.5	M6	16
608□	129	90	134	75	120	52	99	144	12	12	13	37	9	22	35	6	6	3.5	M6	16
609□	142	100	150	90	150	60	135	180	15	15	12	40	11	28	35	8	7	4	M8	20
610□	156	100	150	90	150	60	135	180	15	15	12	40	11	28	35	8	7	4	M8	20
611□	170	120	162	90	150	70	135	180	15	15	12	45	11	32	45	10	8	5	M8	20
612□	186	120	204	115	190	82	155	230	20	20	15	55	14	38	55	10	8	5	M8	20

Model <small>Note 4, 5</small>	Motor		Standard						With Brake					
	kW	P	L	H	H'	J	DM	W(kg)	L	H	H'	J	DM	W(kg)
CNHM01 - 606□ - AV - (B) - Ratio	0.1	4	272	-	138	130	124	8	300	-	138	130	124	9
CNHM02 - 606□ - AV - (B) - Ratio	0.2	4	288	-	138	130	124	9	320	-	138	130	124	10
CNHM01 - 607□ - AV - (B) - Ratio	0.1	4	278	-	138	130	124	8	306	-	138	130	124	9
CNHM02 - 607□ - AV - (B) - Ratio	0.2	4	294	-	138	130	124	9	326	-	138	130	124	10
CNHM01 - 608□ - AV - (B) - Ratio	0.1	4	304	-	157	130	124	11	332	-	157	130	124	12
CNHM02 - 608□ - AV - (B) - Ratio	0.2	4	320	-	157	130	124	13	352	-	157	130	124	14
CNHM05 - 608□ - AV - (B) - Ratio	0.4	4	361	203	-	140	148	17	404	203	-	140	148	18
CNHM02 - 609□ - AV - (B) - Ratio	0.2	4	338	-	175	130	124	14	370	-	175	130	124	16
CNHM05 - 609□ - AV - (B) - Ratio	0.4	4	379	213	-	140	148	18	422	213	-	140	148	21
CNHM1 - 609□ - AV - (B) - Ratio	0.75	4	412	220	-	145	160	21	474	220	-	145	160	26
CNHM02 - 610□ - AV - (B) - Ratio	0.2	4	352	207	-	130	124	19	384	207	-	130	124	21
CNHM05 - 610□ - AV - (B) - Ratio	0.4	4	393	213	-	140	148	23	436	213	-	140	148	26
CNHM1 - 610□ - AV - (B) - Ratio	0.75	4	426	220	-	145	160	27	488	220	-	145	160	32
CNHM2 - 610□ - AV - (B) - Ratio	1.5	4	446	226	-	152	173	31	509	226	-	152	173	37
CNHM1 - 611□ - AV - (B) - Ratio	0.75	4	436	240	-	145	160	26	493	240	-	145	160	31
CNHM2 - 611□ - AV - (B) - Ratio	1.5	4	456	246	-	152	173	30	519	246	-	152	173	36
CNHM3 - 611□ - AV - (B) - Ratio	2.2	4	491	266	-	168	212	40	563	266	-	168	212	50
CNHM2 - 612□ - AV - (B) - Ratio	1.5	4	476	246	-	152	173	40	539	246	-	152	173	47
CNHM3 - 612□ - AV - (B) - Ratio	2.2	4	499	266	-	168	212	50	571	266	-	168	212	60
CNHM5 - 612□ - AV - (B) - Ratio	3.7	4	543	266	-	168	212	57	615	266	-	168	212	67

- Note: 4. □ indicates 0 or 5, expressing combination with reduction ratio. Refer to the Selection Table for details.
 5. "B" after the suffix "AV" indicates models equipped with brake.
 6. Dimensions of shaft end: Refer to pages F-28 to F-29 for details.
 7. 30kW or over motors are air over type.
 8. Dimensions in above drawings are subject to change without notice.

Dimension Tables (Horizontal Direction, Foot Mount)

CHHM^{Note 1} - 613□ to 616□ - AV

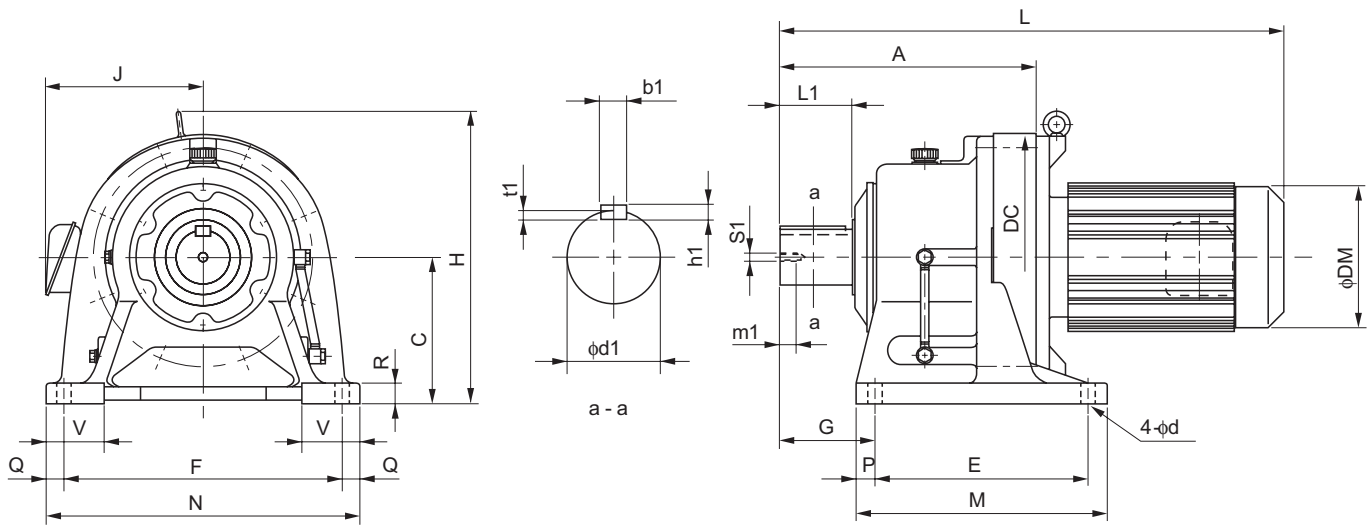

Frame size <small>Note 4</small>	A	C	DC	E	F	G	M	N	P	Q	R	V	d	Output Shaft <small>Note 2, 3, 6</small>						
														d1	L1	b1	h1	t1	S1	m1
613□	240	150	230	145	290	100	195	330	25	20	22	65	18	50	70	14	9	5.5	M10	18
<small>Note 8</small> 614□	260	150	230	145	290	120	195	330	25	20	22	65	18	50	90	14	9	5.5	M10	18
<small>Note 8</small> 616□	308	160	300	150	370	139	238	410	44	20	25	75	18	60	90	18	11	7	M10	18

Model <small>Note 4, 5</small>	Motor		Standard					With Brake				
	kW	P	L	H	J	DM	W(kg)	L	H	J	DM	W(kg)
CHHM2 - 613□ - AV - (B) - Ratio	1.5	4	530	274	152	173	58	593	274	152	173	65
CHHM3 - 613□ - AV - (B) - Ratio	2.2	4	553	296	168	212	68	625	296	168	212	78
CHHM5 - 613□ - AV - (B) - Ratio	3.7	4	597	296	168	212	75	669	296	168	212	85
CHHM8 - 613□ - AV - (B) - Ratio	5.5	4	620	323	213	251	90	715	323	213	251	108
CHHM10 - 613□ - AV - (B) - Ratio	7.5	4	680	323	213	251	103	775	323	213	251	121
*CHHM15 - 613□ - AV - (B) - Ratio	11	4	770	358	261	324	155	875	321	261	324	189
CHHM3 - 614□ - AV - (B) - Ratio	2.2	4	573	296	168	212	69	645	296	168	212	79
CHHM5 - 614□ - AV - (B) - Ratio	3.7	4	617	296	168	212	76	689	296	168	212	86
CHHM8 - 614□ - AV - (B) - Ratio	5.5	4	640	323	213	251	91	735	323	213	251	109
CHHM10 - 614□ - AV - (B) - Ratio	7.5	4	700	323	213	251	104	795	323	213	251	122
*CHHM15 - 614□ - AV - (B) - Ratio	11	4	790	358	261	324	156	895	321	261	324	190
CHHM3 - 616□ - AV - (B) - Ratio	2.2	4	621	310	168	212	106	693	310	168	212	116
CHHM5 - 616□ - AV - (B) - Ratio	3.7	4	665	310	168	212	113	737	310	168	212	123
CHHM8 - 616□ - AV - (B) - Ratio	5.5	4	693	333	213	251	129	788	333	213	251	146
CHHM10 - 616□ - AV - (B) - Ratio	7.5	4	753	333	213	251	143	848	333	213	251	160
*CHHM15 - 616□ - AV - (B) - Ratio	11	4	838	368	261	324	196	943	368	261	324	230
*CHHM20 - 616□ - AV - (B) - Ratio	15	4	933	368	340	394	272	1098	368	340	394	323

*** indicates models with bottom level of the motor lower than the reducer base.
Refer to pages D-33 and D-34 for center height options.

- Note: 1. □ indicates motor capacity.
2. Dimension of shaft end diameter: Dimension tolerance conforms to JIS B 0401-1976 "h6."
3. Dimension of shaft end key: Dimension tolerance conforms to JIS B 1301-1996 "Parallel Key."

Dimension Tables (Horizontal Direction, Foot-Mount)

CHHM^{Note 1} - 617□ to 619□ - AV

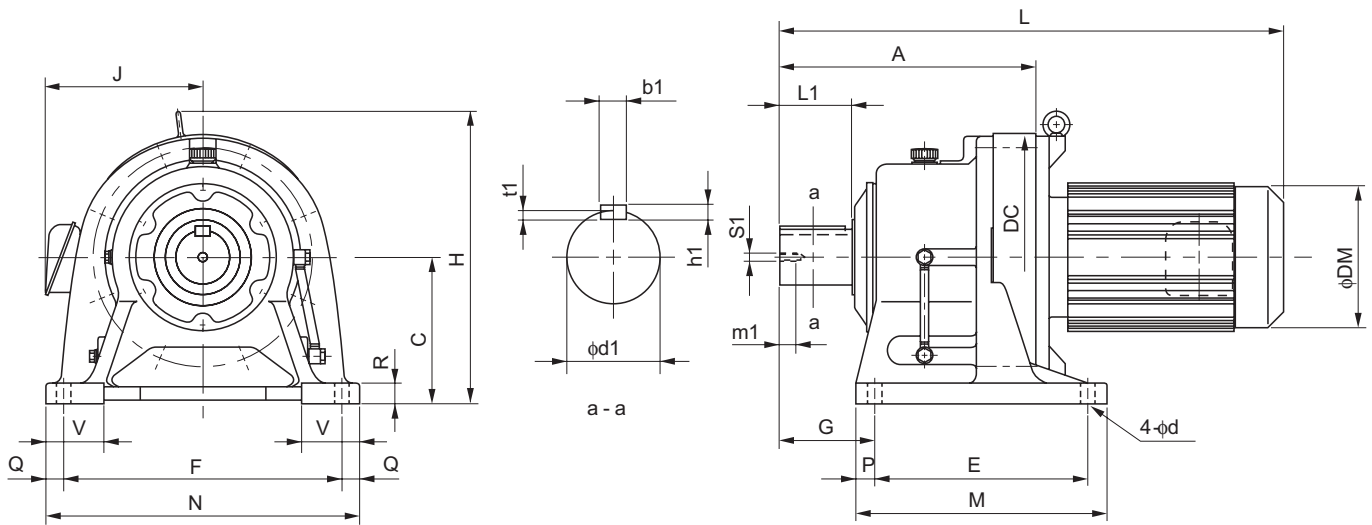

Frame size <small>Note 4</small>	A	C	DC	E	F	G	M	N	P	Q	R	V	d	Output Shaft <small>Note 2, 3, 6</small>						
														d1	L1	b1	h1	t1	S1	m1
617□	352	200	340	275	380	125	335	430	30	25	30	80	22	70	90	20	12	7.5	M12	24
618□	389	220	370	320	420	145	380	470	30	25	30	85	22	80	110	22	14	9	M12	24
619□	465	250	430	380	480	170	440	530	30	25	35	90	26	95	135	25	14	9	M20	34

Model <small>Note 4, 5</small>	Motor		Standard					With Brake				
	kW	P	L	H	J	DM	W(kg)	L	H	J	DM	W(kg)
CHHM8 - 617□ - AV - (B) - Ratio	5.5	4	742	403	213	251	169	837	403	213	251	187
CHHM10 - 617□ - AV - (B) - Ratio	7.5	4	802	403	213	251	183	897	403	213	251	201
CHHM15 - 617□ - AV - (B) - Ratio	11	4	882	413	261	324	237	987	413	261	324	271
CHHM20 - 617□ - AV - (B) - Ratio	15	4	977	428	340	394	309	1142	428	340	394	360
CHHM25 - 617□ - AV - (B) - Ratio	18.5	4	977	428	340	394	309	1142	428	340	394	360
CHHM30 - 617□ - AV - (B) - Ratio	22	4	977	428	340	394	326	1142	428	340	394	369
CHHM10 - 618□ - AV - (B) - Ratio	7.5	4	839	438	213	251	221	934	438	213	251	239
CHHM15 - 618□ - AV - (B) - Ratio	11	4	919	438	261	324	281	1024	438	261	324	310
CHHM20 - 618□ - AV - (B) - Ratio	15	4	1014	448	340	394	347	1179	448	340	394	398
CHHM25 - 618□ - AV - (B) - Ratio	18.5	4	1014	448	340	394	347	1179	448	340	394	398
CHHM30 - 618□ - AV - (B) - Ratio	22	4	1014	448	340	394	364	1179	448	340	394	407
CHHM40 - 618□ - AV - (B) - Ratio	30 <small>Note 7</small>	4	1159	481	340	394	314	1411	481	340	394	510
CHHM15 - 619□ - AV - (B) - Ratio	11	4	995	467	261	324	346	1100	467	261	324	381
CHHM20 - 619□ - AV - (B) - Ratio	15	4	1090	511	340	394	422	1255	511	340	394	467
CHHM25 - 619□ - AV - (B) - Ratio	18.5	4	1090	511	340	394	422	1255	511	340	394	467
CHHM30 - 619□ - AV - (B) - Ratio	22	4	1090	511	340	394	437	1255	511	340	394	480
CHHM40 - 619□ - AV - (B) - Ratio	30 <small>Note 7</small>	4	1235	511	340	394	477	1487	511	340	394	573
CHHM406 - 619□ - AV - (B) - Ratio	30 <small>Note 7</small>	6	1235	511	340	394	477	1487	511	340	394	573
CHHM50 - 619□ - AV - (B) - Ratio	37 <small>Note 7</small>	4	1235	511	340	394	478	1487	511	340	394	573
CHHM506 - 619□ - AV - (B) - Ratio	37 <small>Note 7</small>	6	1290	511	390	484	569	-	-	-	-	-

- Note: 4. □ indicates 0 or 5, expressing combination with reduction ratio. Refer to the Selection Table for details.
 5. "B" after the suffix "AV" indicates models equipped with brake.
 6. Dimensions of shaft end: Refer to pages F-28 to F-29 for details.
 7. 30kW or over motors are air over type.
 8. Dimensions in above drawings are subject to change without notice.

Dimension Tables (Horizontal Direction, Foot Mount)

CHHM^{Note 1} - 6205 to 6255 - AV

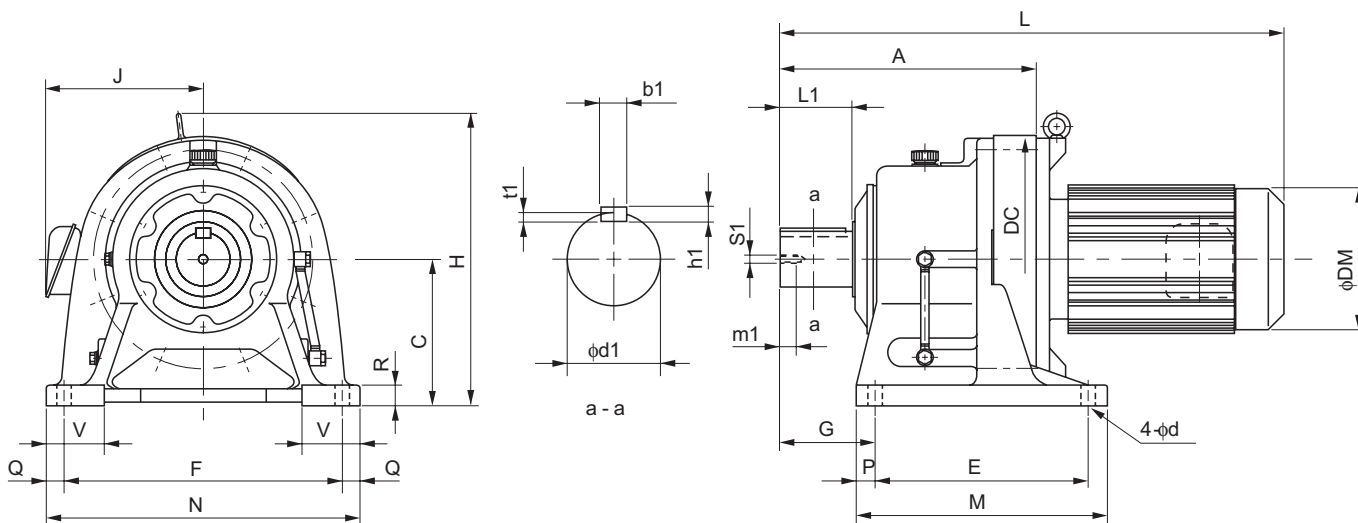

GEARMOTOR FOR INVERTERS
Dimension Tables
CHHM

Frame size	A	C	DC	E	F	G	M	N	P	Q	R	V	d	Output Shaft <small>Note 2, 3, 6</small>						
														d1	L1	b1	h1	t1	S1	m1
6205	502	250	448	360	440	215	440	530	40	45	35	100	26	100	165	28	16	10	M20	34
6215	526	265	485	395	480	210	475	580	40	50	40	110	26	110	165	28	16	10	M20	34
6225	566	280	526	420	540	230	520	620	50	40	40	115	33	120	165	32	18	11	M20	34
6235	628	300	562	460	580	260	560	670	50	45	45	120	33	130	200	32	18	11	M24	41
6245	657	335	614	480	630	263	580	720	50	45	45	128	39	140	200	36	20	12	M24	41
6255	775	375	670	520	670	320	630	780	55	55	50	140	39	160	240	40	22	13	M30	49

Model	Motor		Standard					With Brake				
	kW	P	L	H	J	DM	W(kg)	L	H	J	DM	W(kg)
CHHM20 - 6205 - AV - (B) - Ratio	15	4	1127	530	340	394	443	1292	530	340	394	488
CHHM30 - 6205 - AV - (B) - Ratio	22	4	1127	530	340	394	456	1292	530	340	394	501
CHHM40 - 6205 - AV - (B) - Ratio	30 <small>Note 7</small>	4	1272	530	340	394	496	1524	530	340	394	589
CHHM25 - 6215 - AV - (B) - Ratio	18.5	4	1151	575	340	394	520	1316	575	340	394	565
CHHM40 - 6215 - AV - (B) - Ratio	30 <small>Note 7</small>	4	1296	575	340	394	573	1548	575	340	394	667
CHHM406 - 6215 - AV - (B) - Ratio	30 <small>Note 7</small>	6	1296	575	340	394	573	1548	575	340	394	667
CHHM50 - 6215 - AV - (B) - Ratio	37 <small>Note 7</small>	4	1296	575	340	394	573	1548	575	340	394	667
CHHM30 - 6225 - AV - (B) - Ratio	22	4	1191	610	340	394	618	1401	610	340	394	663
CHHM50 - 6225 - AV - (B) - Ratio	37 <small>Note 7</small>	4	1336	610	340	394	658	1588	610	340	394	752
CHHM406 - 6235 - AV - (B) - Ratio	30 <small>Note 7</small>	6	1398	667	340	394	751	1650	667	340	394	838
CHHM506 - 6245 - AV - (B) - Ratio	37 <small>Note 7</small>	6	1482	729	390	484	967	-	-	-	-	-
CHHM506 - 6255 - AV - (B) - Ratio	37 <small>Note 7</small>	6	1600	815	390	484	1286	-	-	-	-	-

Note: 1. □ indicates motor capacity.
 2. Dimension of shaft end diameter: Dimension tolerance conforms to JIS B 0401-1976 "h6."
 3. Dimension of shaft end key: Dimension tolerance conforms to JIS B 1301-1996 "Parallel Key."

Dimension Tables (Universal Direction, Foot Mount)

CNHM^{Note 1} - 607□DA to 612□DB - AV

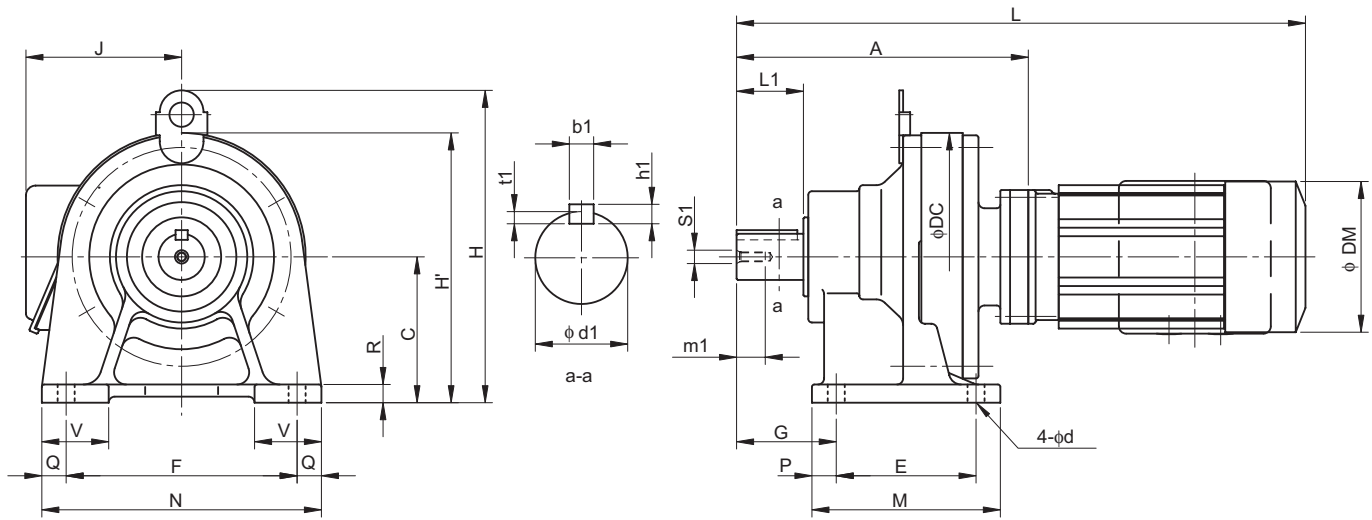

Frame size <small>Note 4</small>	A	C	DC	E	F	G	M	N	P	Q	R	V	d	Output Shaft <small>Note 2, 3, 6</small>						
														d1	L1	b1	h1	t1	S1	m1
607□DA	131	80	110	60	120	47	84	144	12	12	10	35	9	18	30	6	6	3.5	M6	16
609□DA	190	100	150	90	150	60	135	180	15	15	12	40	11	28	35	8	7	4	M8	20
610□DA	204	100	150	90	150	60	135	180	15	15	12	40	11	28	35	8	7	4	M8	20
612□DA	240	120	204	115	190	82	155	230	20	20	15	55	14	38	55	10	8	5	M8	20
612□DB	252	120	204	115	190	82	155	230	20	20	15	55	14	38	55	10	8	5	M8	20

Model <small>Note 4, 5</small>	Motor		Standard							With Brake					
	kW	P	L	H	H'	J	DM	W(kg)	L	H	H'	J	DM	W(kg)	
CNHM01 - 607□DA - AV - (B) - Ratio	0.1	4	311	-	140	130	124	10	339	-	138	130	124	11	
CNHM01 - 609□DA - AV - (B) - Ratio	0.1	4	370	207	-	130	124	18	398	207	-	130	124	19	
CNHM02 - 609□DA - AV - (B) - Ratio	0.2	4	386	207	-	130	124	19	418	207	-	130	124	20	
CNHM01 - 610□DA - AV - (B) - Ratio	0.1	4	384	207	-	130	124	20	412	207	-	130	124	21	
CNHM02 - 610□DA - AV - (B) - Ratio	0.2	4	400	207	-	130	124	21	432	207	-	130	124	22	
CNHM01 - 612□DA - AV - (B) - Ratio	0.1	4	420	257	-	130	124	31	448	257	-	130	124	32	
CNHM02 - 612□DA - AV - (B) - Ratio	0.2	4	436	257	-	130	124	32	468	257	-	130	124	33	
CNHM05 - 612□DB - AV - (B) - Ratio	0.4	4	489	257	-	140	148	39	532	257	-	140	148	42	
CNHM1 - 612□DB - AV - (B) - Ratio	0.75	4	516	257	-	145	160	42	578	257	-	145	160	47	

- Note: 4. □ indicates 0 or 5, expressing combination with reduction ratio. Refer to the Selection Table for details.
 5. "B" after the suffix "AV" indicates models equipped with brake.
 6. Dimensions of shaft end: Refer to pages F-28 to F-29 for details.
 7. 30kW or over motors are air over type.
 8. Dimensions in above drawings are subject to change without notice.

Dimension Tables (Horizontal Direction, Foot Mount)

CHHM^{Note 1} - 613□DA to 618□DA - AV

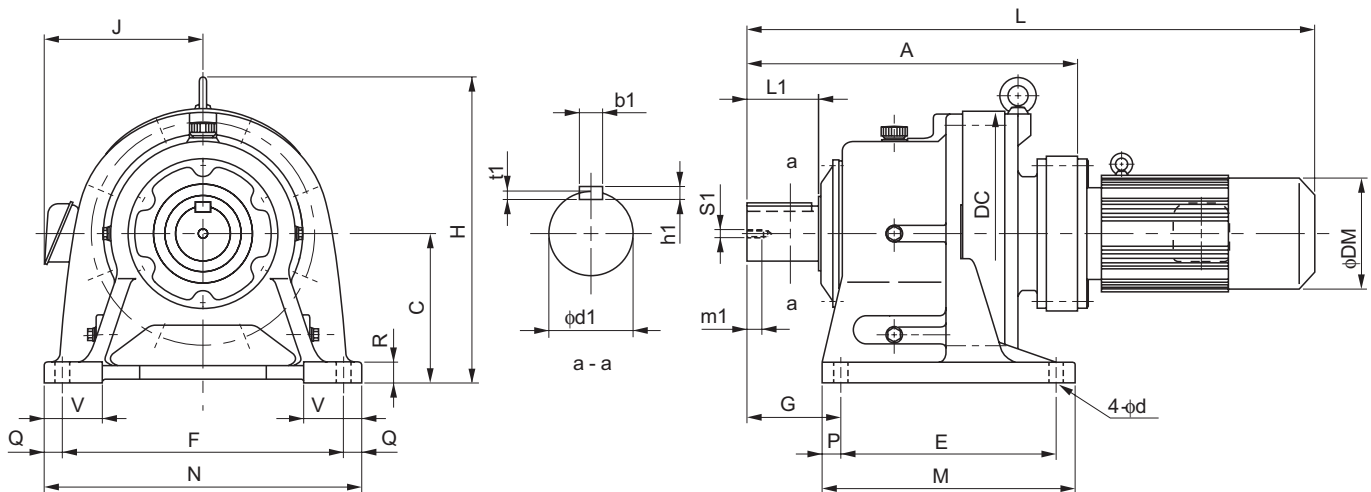

GEARMOTOR FOR INVERTERS
Dimension Tables
CHHM

Frame size <small>Note 4</small>	A	C	DC	E	F	G	M	N	P	Q	R	V	d	Output Shaft <small>Note 2, 3, 6</small>						
														d1	L1	b1	h1	t1	S1	m1
613□DA	294	150	230	145	290	100	195	330	25	20	22	65	18	50	70	14	9	5.5	M10	18
613□DB	303	150	230	145	290	100	195	330	25	20	22	65	18	50	70	14	9	5.5	M10	18
613□DC	317	150	230	145	290	100	195	330	25	20	22	65	18	50	70	14	9	5.5	M10	18
614□DA	314	150	230	145	290	120	195	330	25	20	22	65	18	50	90	14	9	5.5	M10	18
614□DB	323	150	230	145	290	120	195	330	25	20	22	65	18	50	90	14	9	5.5	M10	18
614□DC	337	150	230	145	290	120	195	330	25	20	22	65	18	50	90	14	9	5.5	M10	18
616□DA	373	160	300	150	370	139	238	410	44	20	25	75	18	60	90	18	11	7	M10	18
616□DB	387	160	300	150	370	139	238	410	44	20	25	75	18	60	90	18	11	7	M10	18
617□DA	418	200	340	275	380	125	335	430	30	25	30	80	22	70	90	20	12	7.5	M12	24
617□DB	432	200	340	275	380	125	335	430	30	25	30	80	22	70	90	20	12	7.5	M12	24
618□DA	474	220	370	320	420	145	380	470	30	25	30	85	22	80	110	22	14	9	M12	24

Model <small>Note 4, 5</small>	Motor		Standard					With Brake				
	kW	P	L	H	J	DM	W(kg)	L	H	J	DM	W(kg)
CHHM02 - 613□DA - AV - (B) - Ratio	0.2	4	490	300	130	124	47	522	300	130	124	48
CHHM05 - 613□DB - AV - (B) - Ratio	0.4	4	540	265	140	148	54	583	265	140	148	57
CHHM1 - 613□DB - AV - (B) - Ratio	0.75	4	573	270	145	160	57	635	270	145	160	62
CHHM2 - 613□DC - AV - (B) - Ratio	1.5	4	607	276	152	173	64	670	276	152	173	70
CHHM02 - 614□DA - AV - (B) - Ratio	0.2	4	510	300	130	124	48	542	300	130	124	49
CHHM05 - 614□DB - AV - (B) - Ratio	0.4	4	560	265	140	148	54	603	265	140	148	57
CHHM1 - 614□DB - AV - (B) - Ratio	0.75	4	593	270	145	160	57	655	270	145	160	62
CHHM2 - 614□DC - AV - (B) - Ratio	1.5	4	627	276	152	173	61	690	276	152	173	70
CHHM02 - 616□DA - AV - (B) - Ratio	0.2	4	569	349	130	124	91	601	349	130	124	93
CHHM05 - 616□DA - AV - (B) - Ratio	0.4	4	610	349	140	148	95	653	349	140	148	98
CHHM1 - 616□DA - AV - (B) - Ratio	0.75	4	643	349	145	160	99	705	349	145	160	104
CHHM2 - 616□DB - AV - (B) - Ratio	1.5	4	677	349	152	173	105	740	349	152	173	111
CHHM02 - 617□DA - AV - (B) - Ratio	0.2	4	614	416	130	124	126	646	416	130	124	128
CHHM05 - 617□DA - AV - (B) - Ratio	0.4	4	655	416	140	148	130	698	416	140	148	133
CHHM1 - 617□DA - AV - (B) - Ratio	0.75	4	688	416	145	160	134	750	416	145	160	139
CHHM2 - 617□DB - AV - (B) - Ratio	1.5	4	722	416	152	173	140	785	416	152	173	146
CHHM05 - 618□DA - AV - (B) - Ratio	0.4	4	711	451	140	148	176	754	451	140	148	178
CHHM1 - 618□DA - AV - (B) - Ratio	0.75	4	744	451	145	160	179	806	451	145	160	184
CHHM2 - 618□DA - AV - (B) - Ratio	1.5	4	764	451	152	173	183	827	451	152	173	189

- Note: 1. □ indicates motor capacity.
 2. Dimension of shaft end diameter: Dimension tolerance conforms to JIS B 0401-1976 "h6."
 3. Dimension of shaft end key: Dimension tolerance conforms to JIS B 1301-1996 "Parallel Key."

Dimension Tables (Horizontal Direction, Foot-Mount)

CHHM^{Note 1} - 616□DC to 619□DB - AV

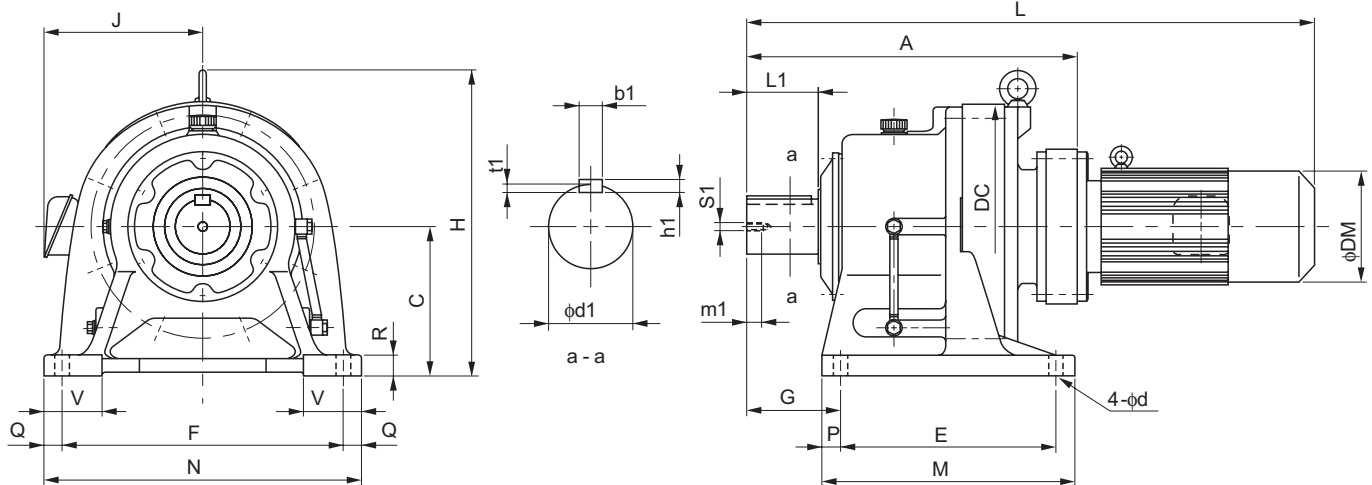

Frame size <small>Note 4</small>	A	C	DC	E	F	G	M	N	P	Q	R	V	d	Output Shaft <small>Note 2, 3, 6</small>						
														d1	L1	b1	h1	t1	S1	m1
616□DC	389	160	300	150	370	139	238	410	44	20	25	75	18	60	90	18	11	7	M10	18
617□DC	436	200	340	275	380	125	335	430	30	25	30	80	22	70	90	20	12	7.5	M12	24
618□DB	496	220	370	320	420	145	380	470	30	25	30	85	22	80	110	22	14	9	M12	24
619□DA	556	250	430	380	480	170	440	530	30	25	35	90	26	95	135	25	14	9	M20	34
619□DB	572	250	430	380	480	170	440	530	30	25	35	90	26	95	135	25	14	9	M20	34

Model <small>Note 4, 5</small>	Motor		Standard					With Brake				
	kW	P	L	H	J	DM	W(kg)	L	H	J	DM	W(kg)
CHHM3 - 616□DC - AV - (B) - Ratio	2.2	4	702	349	168	212	121	774	349	147	212	131
CHHM5 - 616□DC - AV - (B) - Ratio	3.7	4	746	349	168	212	128	818	349	147	212	138
CHHM3 - 617□DC - AV - (B) - Ratio	2.2	4	749	416	168	212	155	821	416	147	212	165
CHHM5 - 617□DC - AV - (B) - Ratio	3.7	4	793	416	168	212	162	865	416	147	212	172
CHHM3 - 618□DB - AV - (B) - Ratio	2.2	4	809	451	168	212	207	881	451	147	212	217
CHHM5 - 618□DB - AV - (B) - Ratio	3.7	4	853	451	168	212	214	925	451	147	212	224
CHHM8 - 618□DB - AV - (B) - Ratio	5.5	4	876	451	213	251	229	971	451	188	251	247
CHHM10 - 618□DB - AV - (B) - Ratio	7.5	4	936	451	213	251	243	1031	451	188	251	261
CHHM1 - 619□DA - AV - (B) - Ratio	0.75	4	826	531	145	160	254	888	531	119	160	259
CHHM2 - 619□DA - AV - (B) - Ratio	1.5	4	846	531	152	173	258	909	531	126	173	265
CHHM3 - 619□DA - AV - (B) - Ratio	2.2	4	869	531	168	212	268	941	531	147	212	278
CHHM5 - 619□DA - AV - (B) - Ratio	3.7	4	913	531	168	212	275	985	531	147	212	285
CHHM8 - 619□DB - AV - (B) - Ratio	5.5	4	952	531	213	251	297	1047	531	188	251	315
CHHM10 - 619□DB - AV - (B) - Ratio	7.5	4	1012	531	213	251	311	1107	531	188	251	329
CHHM15 - 619□DB - AV - (B) - Ratio	11	4	1102	531	232	324	363	1207	531	259	324	397

- Note: 4. □ indicates 0 or 5, expressing combination with reduction ratio. Refer to the Selection Table for details.
 5. "B" after the suffix "AV" indicates models equipped with brake.
 6. Dimensions of shaft end: Refer to pages F-28 to F-29 for details.
 7. 30kW or over motors are air over type.
 8. Dimensions in above drawings are subject to change without notice.

Dimension Tables (Horizontal Direction, Foot Mount)

CHHM □ - 6205DA to 6225DB - AV

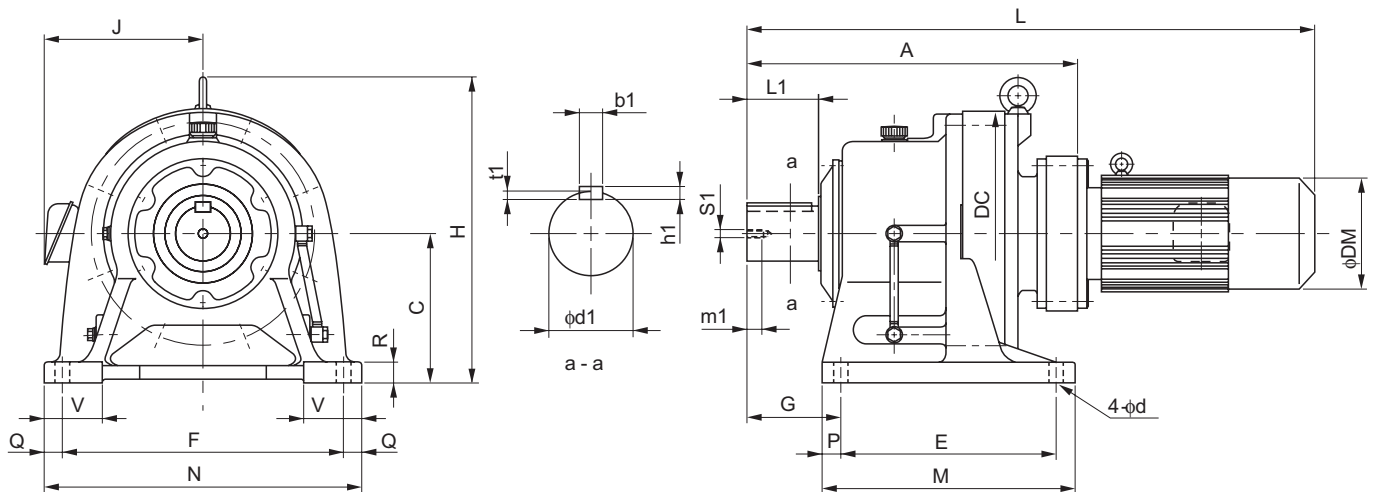

Frame size <small>Note 4</small>	A	C	DC	E	F	G	M	N	P	Q	R	V	d	Output Shaft <small>Note 2, 3, 6</small>						
														d1	L1	b1	h1	t1	S1	m1
6205DA	597	250	448	360	440	215	440	530	40	45	35	100	26	100	165	28	16	10	M20	34
6205DB	624	250	448	360	440	215	440	530	40	45	35	100	26	100	165	28	16	10	M20	34
6215DA	650	265	485	395	480	210	475	580	40	50	40	110	26	110	165	28	16	10	M20	34
6215DB	675	265	485	395	480	210	475	580	40	50	40	110	26	110	165	28	16	10	M20	34
6225DA	692	280	526	420	540	230	520	620	50	40	40	115	33	120	165	32	18	11	M20	34
6225DB	735	280	526	420	540	230	520	620	50	40	40	115	33	120	165	32	18	11	M20	34

Model <small>Note 4, 5</small>	Motor		Standard					With Brake				
	kW	P	L	H	J	DM	W(kg)	L	H	J	DM	W(kg)
CHHM1 - 6205DA - AV - (B) - Ratio	0.75	4	867	530	145	160	273	929	530	145	160	278
CHHM3 - 6205DA - AV - (B) - Ratio	2.2	4	910	530	168	212	287	982	530	168	212	297
CHHM8 - 6205DB - AV - (B) - Ratio	5.5	4	1004	530	213	251	321	1099	530	213	251	339
CHHM10 - 6205DB - AV - (B) - Ratio	7.5	4	1064	530	188	251	334	1159	530	188	251	352
CHHM15 - 6205DB - AV - (B) - Ratio	11	4	1154	530	232	324	386	1249	530	259	324	419
CHHM2 - 6215DA - AV - (B) - Ratio	1.5	4	940	575	152	173	370	1003	575	152	173	377
CHHM3 - 6215DA - AV - (B) - Ratio	2.2	4	963	575	168	212	380	1035	575	168	212	390
CHHM5 - 6215DA - AV - (B) - Ratio	3.7	4	1007	575	168	212	387	1079	575	168	212	397
CHHM8 - 6215DA - AV - (B) - Ratio	5.5	4	1030	575	213	251	402	1125	575	213	251	420
CHHM10 - 6215DA - AV - (B) - Ratio	7.5	4	1090	575	188	251	415	1185	575	188	251	433
CHHM15 - 6215DA - AV - (B) - Ratio	11	4	1180	575	232	324	467	1285	575	259	324	501
CHHM20 - 6215DB - AV - (B) - Ratio	15	4	1300	575	297	394	564	1465	575	297	394	615
CHHM2 - 6225DA - AV - (B) - Ratio	1.5	4	982	610	152	173	444	1045	640	152	173	451
CHHM3 - 6225DA - AV - (B) - Ratio	2.2	4	1005	610	168	212	454	1077	610	168	212	464
CHHM5 - 6225DA - AV - (B) - Ratio	3.7	4	1049	610	168	212	461	1121	610	168	212	471
CHHM8 - 6225DA - AV - (B) - Ratio	5.5	4	1072	610	213	251	476	1167	610	213	251	494
CHHM10 - 6225DA - AV - (B) - Ratio	7.5	4	1132	610	213	251	490	1227	610	213	251	508
CHHM15 - 6225DA - AV - (B) - Ratio	11	4	1222	610	232	324	542	1327	610	259	324	576
CHHM20 - 6225DB - AV - (B) - Ratio	15	4	1360	610	340	394	661	1525	610	340	394	712
CHHM25 - 6225DB - AV - (B) - Ratio	18.5	4	1360	610	340	394	661	1525	610	340	394	712
CHHM30 - 6225DB - AV - (B) - Ratio	22	4	1360	610	340	394	678	1525	610	340	394	729

- Note: 1. □ indicates motor capacity.
 2. Dimension of shaft end diameter: Dimension tolerance conforms to JIS B 0401-1976 "h6."
 3. Dimension of shaft end key: Dimension tolerance conforms to JIS B 1301-1996 "Parallel Key."

Dimension Tables (Horizontal Direction, Foot Mount)

CHHM^{Note 1} - 6235DA to 6255DB - AV

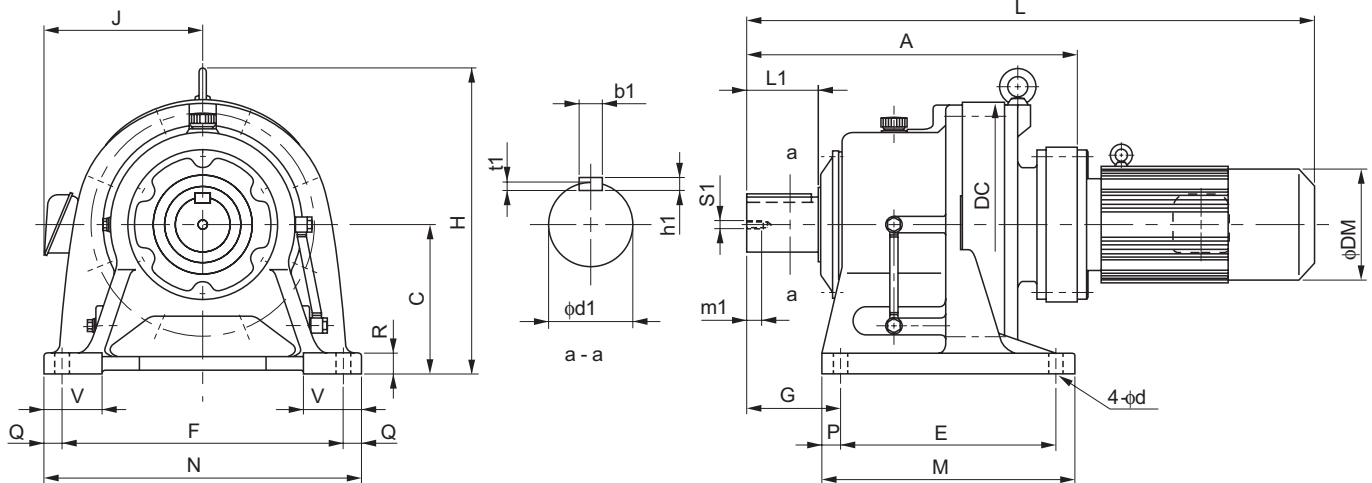

Frame size	A	C	DC	E	F	G	M	N	P	Q	R	V	d	Output Shaft ^{Note 2, 3, 6}						
														d1	L1	b1	h1	t1	S1	m1
6235DA	778	300	562	460	580	260	560	670	50	45	45	120	33	130	200	32	18	11	M24	41
6235DB	800	300	562	460	580	260	560	670	50	45	45	120	33	130	200	32	18	11	M24	41
6245DA	816	335	614	480	630	263	580	720	50	45	45	128	39	140	200	36	20	12	M24	41
6245DB	837	335	614	480	630	263	580	720	50	45	45	128	39	140	200	36	20	12	M24	41
6255DA	956	375	670	520	670	320	630	780	55	55	50	140	39	160	240	40	22	13	M30	49
6255DB	978	375	670	520	670	320	630	780	55	55	50	140	39	160	240	40	22	13	M30	49

Model	Motor ^{Note 5}	Motor		Standard					With Brake				
		kW	P	L	H	J	DM	W(kg)	L	H	J	DM	W(kg)
CHHM3 - 6235DA - AV - (B) - Ratio		2.2	4	1091	667	168	212	570	1163	667	168	212	580
CHHM5 - 6235DA - AV - (B) - Ratio		3.7	4	1135	667	168	212	577	1207	667	168	212	587
CHHM8 - 6235DA - AV - (B) - Ratio		5.5	4	1163	667	213	251	593	1258	667	213	251	610
CHHM10 - 6235DA - AV - (B) - Ratio		7.5	4	1223	667	213	251	607	1318	667	213	251	624
CHHM15 - 6235DA - AV - (B) - Ratio		11	4	1308	667	261	324	660	1413	667	261	324	694
CHHM20 - 6235DA - AV - (B) - Ratio		15	4	1403	667	340	394	737	1568	667	340	394	788
CHHM25 - 6235DB - AV - (B) - Ratio		18.5	4	1425	667	340	394	782	1590	667	340	394	825
CHHM30 - 6235DB - AV - (B) - Ratio		22	4	1425	667	340	394	782	1590	667	340	394	825
CHHM40 - 6235DB - AV - (B) - Ratio		30 ^{Note 7}	4	1570	667	340	394	822	1822	667	340	394	918
CHHM3 - 6245DA - AV - (B) - Ratio		2.2	4	1129	729	168	212	679	1201	729	168	212	689
CHHM5 - 6245DA - AV - (B) - Ratio		3.7	4	1173	729	168	212	686	1245	729	168	212	696
CHHM8 - 6245DA - AV - (B) - Ratio		5.5	4	1201	729	213	251	702	1296	729	213	251	719
CHHM10 - 6245DA - AV - (B) - Ratio		7.5	4	1261	729	213	251	716	1356	729	213	251	733
CHHM15 - 6245DA - AV - (B) - Ratio		11	4	1346	729	261	324	769	1451	729	261	324	803
CHHM20 - 6245DA - AV - (B) - Ratio		15	4	1441	729	340	394	840	1606	729	340	394	891
CHHM25 - 6245DB - AV - (B) - Ratio		18.5	4	1462	729	340	394	866	1627	729	340	394	917
CHHM30 - 6245DB - AV - (B) - Ratio		22	4	1462	729	340	394	883	1627	729	340	394	926
CHHM40 - 6245DB - AV - (B) - Ratio		30 ^{Note 7}	4	1607	729	340	394	937	1859	729	340	394	1033
CHHM5 - 6255DA - AV - (B) - Ratio		3.7	4	1328	815	168	212	1041	1400	815	168	212	1049
CHHM8 - 6255DA - AV - (B) - Ratio		5.5	4	1346	815	213	251	1056	1441	815	213	251	1071
CHHM10 - 6255DA - AV - (B) - Ratio		7.5	4	1406	815	213	251	1071	1501	815	213	251	1086
CHHM15 - 6255DA - AV - (B) - Ratio		11	4	1486	815	261	324	1103	1591	815	261	324	1157
CHHM20 - 6255DA - AV - (B) - Ratio		15	4	1581	815	340	394	1195	1746	815	340	394	1246
CHHM25 - 6255DA - AV - (B) - Ratio		18.5	4	1581	815	340	394	1195	1746	815	340	394	1246
CHHM30 - 6255DA - AV - (B) - Ratio		22	4	1581	815	340	394	1215	1746	815	340	394	1258
CHHM40 - 6255DB - AV - (B) - Ratio		30 ^{Note 7}	4	1748	815	340	394	1325	2000	815	340	394	1421
CHHM50 - 6255DB - AV - (B) - Ratio		37 ^{Note 7}	4	1748	815	340	394	1325	2000	815	340	394	1421

- Note: 4. □ indicates 0 or 5, expressing combination with reduction ratio. Refer to the Selection Table for details.
 5. "B" after the suffix "AV" indicates models equipped with brake.
 6. Dimensions of shaft end: Refer to pages F-28 to F-29 for details.
 7. 30kW or over motors are air over type.
 8. Dimensions in above drawings are subject to change without notice.

Dimension Tables (Horizontal Direction, Foot Mount)

CHHM - 6265DA to 6275DA - AV

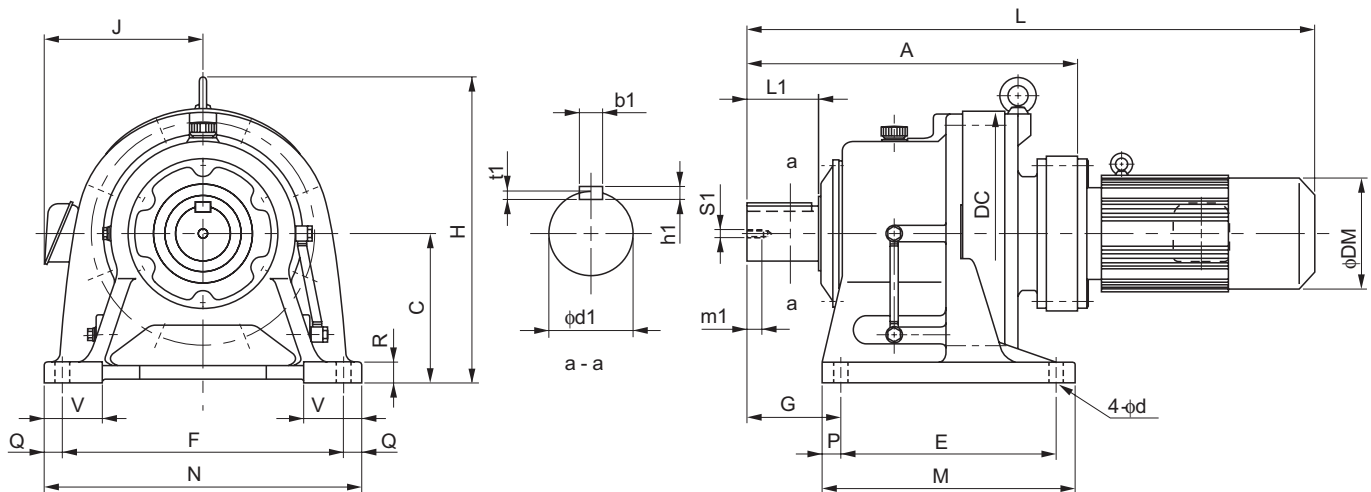

GEARMOTOR FOR INVERTERS
Dimension Tables
CHHM

Frame size	A	C	DC	E	F	G	M	N	P	Q	R	V	d	Output Shaft <small>Note 2, 3, 6</small>						
														d1	L1	b1	h1	t1	S1	m1
6265DA	1088	400	736	590	770	390	700	880	55	55	55	160	45	170	300	40	22	13	M30	49
6275DA	1349	540	950	420	1050	485	1040	1160	100	55	60	200	45	180	330	45	25	15	M30	52

Model <small>Note 5</small>	Motor		Standard					With Brake				
	kW	P	L	H	J	DM	W(kg)	L	H	J	DM	W(kg)
CHHM8 - 6265DA - AV - (B) - Ratio	5.5	4	1493	874	213	251	1381	1588	874	213	251	1401
CHHM10 - 6265DA - AV - (B) - Ratio	7.5	4	1553	874	213	251	1396	1648	874	213	251	1411
CHHM15 - 6265DA - AV - (B) - Ratio	11	4	1618	874	261	324	1446	1723	874	261	324	1482
CHHM20 - 6265DA - AV - (B) - Ratio	15	4	1713	874	340	394	1525	1878	874	340	394	1570
CHHM25 - 6265DA - AV - (B) - Ratio	18.5	4	1713	874	340	394	1525	1878	874	340	394	1570
CHHM30 - 6265DA - AV - (B) - Ratio	22	4	1713	874	340	394	1540	1878	874	340	394	1583
CHHM40 - 6265DA - AV - (B) - Ratio	30 <small>Note 7</small>	4	1858	874	340	394	1577	2110	874	340	394	1673
CHHM50 - 6265DA - AV - (B) - Ratio	37 <small>Note 7</small>	4	1858	874	340	394	1577	2110	874	340	394	1673
CHHM10 - 6275DA - AV - (B) - Ratio	7.5	4	1814	1161	213	251	2531	1909	1161	213	251	2546
CHHM15 - 6275DA - AV - (B) - Ratio	11	4	1879	1161	261	324	2581	1984	1161	261	324	2617
CHHM20 - 6275DA - AV - (B) - Ratio	15	4	1974	1161	340	394	2660	2139	1161	340	394	2705
CHHM25 - 6275DA - AV - (B) - Ratio	18.5	4	1974	1161	340	394	2660	2139	1161	340	394	2705
CHHM30 - 6275DA - AV - (B) - Ratio	22	4	1974	1161	340	394	2675	2139	1161	340	394	2718
CHHM40 - 6275DA - AV - (B) - Ratio	30 <small>Note 7</small>	4	2089	1161	340	394	2713	2304	1161	340	394	2810
CHHM50 - 6275DA - AV - (B) - Ratio	37 <small>Note 7</small>	4	2089	1161	340	394	2713	2304	1161	340	394	2810

Notes: 1 indicates motor capacity.
 2 Dimension of shaft end diameter: Dimension tolerance conforms to JIS B 0401-1976 "h6."
 3 Dimension of shaft end key: Dimension tolerance conforms to JIS B 1301-1996 "Parallel Key".

Dimension Tables (Universal Direction, Foot Mount)

CNHM^{Note 2} - 610H, 612H - AV (Center Height Option)

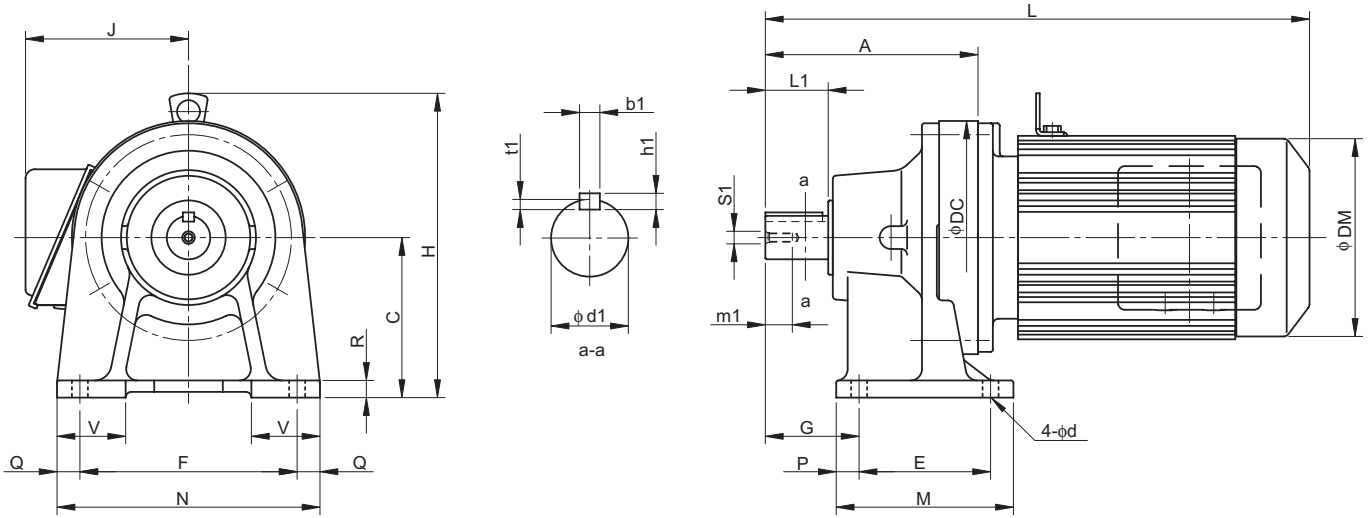

Frame size	A	C	DC	E	F	G	M	N	P	Q	R	V	d	Output Shaft ^{Note 2, 3, 6}						
														d1	L1	b1	h1	t1	S1	m1
610H	156	120	150	90	150	60	135	180	15	15	12	40	11	28	35	8	7	4	M8	20
612H	186	140	204	115	190	82	155	230	20	20	15	60	14	38	55	10	8	5	M8	20

Model ^{Note 4}	Motor		Standard							With Brake					
	kW	P	L	H	H'	J	DM	W(kg)	L	H	H'	J	DM	W(kg)	
CNHM02 - 610H - AV - (B) - Ratio	0.2	4	352	227	-	130	124	20	384	227	-	130	124	22	
CNHM05 - 610H - AV - (B) - Ratio	0.4	4	393	233	-	140	148	24	436	233	-	140	148	27	
CNHM1 - 610H - AV - (B) - Ratio	0.75	4	426	240	-	145	160	28	488	240	-	145	160	33	
CNHM2 - 610H - AV - (B) - Ratio	1.5	4	446	246	-	152	173	32	509	246	-	152	173	38	
CNHM2 - 612H - AV - (B) - Ratio	1.5	4	476	266	-	152	173	41	539	266	-	152	173	48	
CNHM3 - 612H - AV - (B) - Ratio	2.2	4	499	286	-	168	212	51	571	286	-	168	212	61	
CNHM5 - 612H - AV - (B) - Ratio	3.7	4	543	286	-	168	212	58	615	286	-	168	212	68	

- Note: 4. □ indicates 0 or 5, expressing combination with reduction ratio. Refer to the Selection Table for details.
 5. "B" after the suffix "AV" indicates models equipped with brake.
 6. Dimensions of shaft end: Refer to pages F-28 to F-29 for details.
 7. 30kW or over motors are air over type.
 8. Dimensions in above drawings are subject to change without notice.

GEARMOTOR FOR INVERTERS
Dimension Tables
CNHM

Dimension Tables (Horizontal Direction, Foot-Mount)

CHHM^{Note 2} - 614H, 616H - AV (Center Height Option)

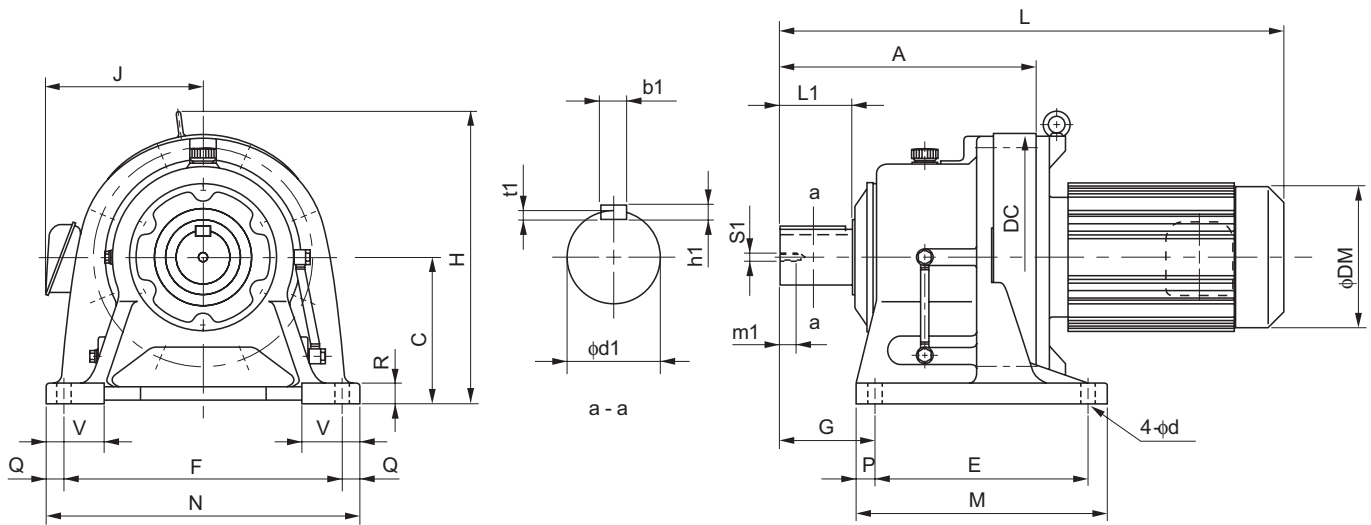

Frame size	A	C	DC	E	F	G	M	N	P	Q	R	V	d	Output Shaft <small>Note 2, 3, 6</small>						
														d1	L1	b1	h1	t1	S1	m1
614H	260	160	230	145	290	120	195	330	25	20	22	70	18	50	90	14	9	5.5	M10	18
616H	308	200	300	150	370	139	238	410	44	20	25	80	18	60	90	18	11	7	M10	18

Model <small>Note 4</small>	Motor		Standard					With Brake				
	kW	P	L	H	J	DM	W(kg)	L	H	J	DM	W(kg)
CHHM3 - 614H - AV - (B) - Ratio	2.2	4	573	306	168	212	71	645	306	168	212	81
CHHM5 - 614H - AV - (B) - Ratio	3.7	4	617	306	168	212	78	689	306	168	212	88
CHHM8 - 614H - AV - (B) - Ratio	5.5	4	640	333	213	251	93	735	333	213	251	111
CHHM10 - 614H - AV - (B) - Ratio	7.5	4	700	333	213	251	107	795	333	213	251	125
*CHHM15 - 614H - AV - (B) - Ratio	11	4	790	368	261	324	159	895	368	261	324	193
CHHM3 - 616H - AV - (B) - Ratio	2.2	4	621	350	168	212	111	693	350	168	212	121
CHHM5 - 616H - AV - (B) - Ratio	3.7	4	665	350	168	212	118	737	350	168	212	128
CHHM8 - 616H - AV - (B) - Ratio	5.5	4	693	373	213	251	134	788	373	213	251	151
CHHM10 - 616H - AV - (B) - Ratio	7.5	4	753	373	213	251	148	848	373	213	251	165
CHHM15 - 616H - AV - (B) - Ratio	11	4	838	408	261	324	201	943	408	261	324	235
CHHM20 - 616H - AV - (B) - Ratio	15	4	933	408	340	394	273	1098	408	340	394	324

*** indicates models with bottom level of the motor lower than the reducer base.

- Note: 1. □ indicates motor capacity.
 2. Dimension of shaft end diameter: Dimension tolerance conforms to JIS B 0401-1976 "h6."
 3. Dimension of shaft end key: Dimension tolerance conforms to JIS B 1301-1996 "Parallel Key."
 4. "B" after the suffix "AV" indicates models equipped with brake.
 5. Dimensions of shaft end: Refer to pages F-28 to F-29 for details.
 6. Dimensions in above drawings are subject to change without notice.

E

CYCLO® GEARMOTORS with High Efficiency Motor

	Page
Product Introduction	E-2
High Efficiency Regulation and Standard	E-4
Basic Gearmotor with High Efficiency	
Motor Specification	E-5

*This section contains a brief description on CYCLO® GEARMOTORS with high efficiency motor.

CYCLO[®] DRIVE with High Efficiency Motor 6000 Series

Sumitomo Drive Technologies have developed a high efficiency motor lineup for CYCLO[®] DRIVE to prevent global warming. It helps curb greenhouse gas emission and satisfies your needs for motors, conforming to energy conservation laws, in various countries that requires power consumption reduction in factories and offices.

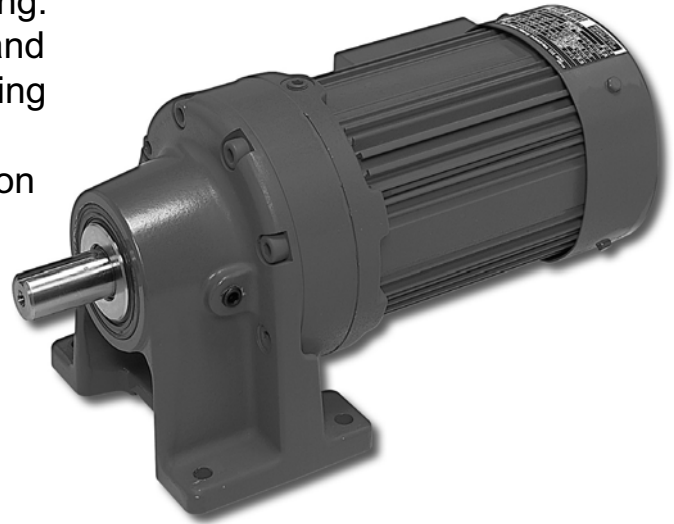
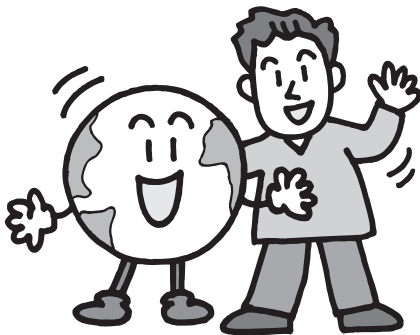

1. Energy Conservation and High Economical Efficiency

Combination of high efficiency motor and CYCLO[®] DRIVE 6000 SERIES enables enhanced energy conservation and higher economic efficiency.

2. Conformity to High Efficiency JIS Standard

Our high-efficiency motor conforms to JISC4212, "High Efficiency Low Voltage Three-Phase Squirrel Cage Motor" enacted on July 20, 2000.

3. Conformity to International Standards

Gearmotor series lineup conforms to safety standards and high efficiency regulation of North America.

- Products conform to UL and CSA standards.
- Products conform to EPC and NRCAN



4. Lightweight and Compact

High grade materials and aluminum frame actualized the most compact and lightweight high efficiency motor.

5. Inverter Drive

Continuous operation at 1:10 with constant torque is enabled by combination of inverter, by reducing loss.



HF-320α



HF-430

Note: Sumitomo inverters HF-320α and HF-430 Series include sensorless vector control function.

Always let us know when operating with inverter drive. CYCLO[®] combination selection requires consideration on lubrication and torque for slow speed operation. In addition, inverter drive operation for 400V class and above requires specific insulation measures.

Continuously Evolving CYCLO[®] DRIVE

Tooth Profile without Breakage^{Note}

CYCLO[®] DRIVE is a tough reducer with long lifetime with contact ratio 2 to 3 times more compared to the involute gear. This is enabled by cycloidal tooth profile of internal gear and epitrochoidal parallel curve of external gear. High-carbon chromium bearing steel, with abrasion and fatigue resistant properties, is used for the reducer part.

Note: Only when used within the rated torque.

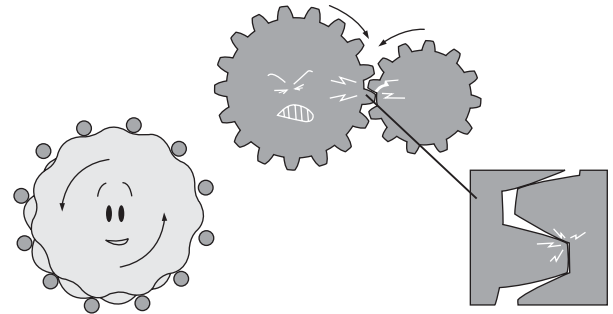

CYCLO[®] DRIVE has smooth rolling contact.

Involute gear has slip contact with less contact ratio.

50# Series (1969~)

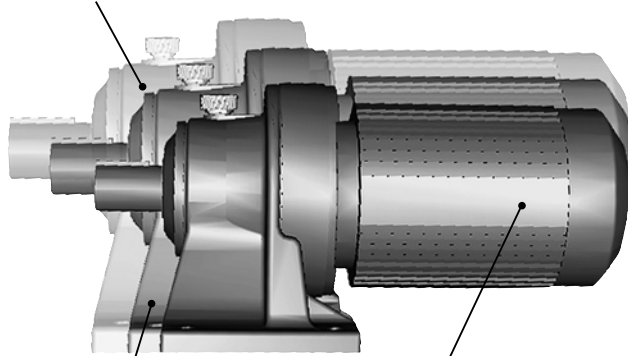

4000# Series (1994~)

6000# Series (2000~)

Size comparison of the combination with same capacity and reduction ratio

Lightweight and Compact

Combination of internal planetary mechanism and cycloidal tooth profile actualized lightweight and compact reducer mechanism. This is why we can easily produce reducers with high reduction ratio which were simply impossible by involute gear stages, such as 1/6~1/119 by single reduction, 1/104~1/7569 by double reduction, and 1/9251~1/658603 by triple reduction. Further, with CYCLO[®] DRIVE 6000 Series, we enabled space-saving by developing high load capacity. We cut down the reducer mass by maximum 40% compared to our conventional gearmotors.

Economy of High Efficiency Motor

Running cost may be lowered by reducing loss using high efficiency motors instead of standard motors. Energy conservation effect will be larger for longer operations at constant speed.

Economy of High Efficiency Motor

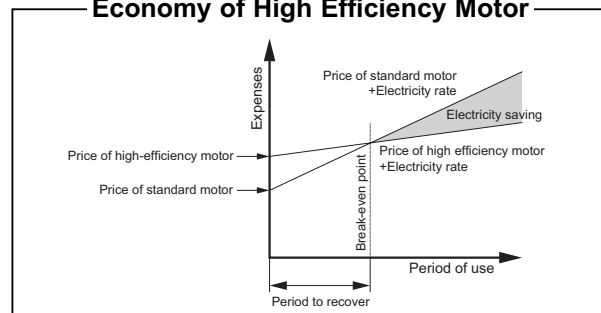

Calculation Example of the Energy-Saving Effect

1. Annual saving on the electricity bill:

$$\text{Annual saving on electricity bill [JPY/yr]} = \text{Input difference of standard motor and high efficiency motor [kW]} \times \text{Operation time [hr/yr]} \times \text{Electricity bill [JPY/kWh]}$$

2. Collection period for money paid on high-efficiency motor:

$$\text{Collection period [yr]} = \frac{\text{Price of high efficiency motor [JPY]} - \text{Price of standard motor [JPY]}}{\text{Annual saving on electricity bill [JPY/yr]}}$$

3. Example

Standard motor is replaced with a high efficiency motor under the following condition:

4-pole; 2.2kW; 220V-60Hz; 50 units; Load factor: 100%; Annual operation: 4,000 hr/yr; Electricity rate: 16JPY/kWh
Annual saving (JPY/yr)

$$= \left[\frac{100}{83.0} + \frac{100}{87.0} \right] \times 2.2\text{kW} \times 50 \text{ units} \times 4,000\text{hr/yr} \times 16\text{JPY/kWh}$$

$$= 390,000 \text{ JPY/yr}$$

CYCLO® GEARMOTORS with High Efficiency Motor

High-Efficiency Regulations and Standards

1. High Efficiency Regulations

US: According to the Energy Policy Act of 1992 (EPAAct), motors and other products with built-in motors sold in the US later than October 24, 1997 are subject to this energy-efficiency regulation. Motors which fail to conform to the standards are penalized. (Subject capacity: 1-200HP; voltage: 230 & 460V; for commercial power supply). Although gearmotors are not included at this point, they may also become subject, observing the movement in Canada, Natural Resources Canada (NRCan) enacted the Energy Efficiency Act (EEAct) in 1992 and the Energy Efficiency Regulation (EER) in 1995. These regulations are applied to standard motors imported to Canada starting February 3, 1995. Additional regulations were applied to gearmotors and explosion-proof motors imported after November 27, 1999. Motors and gearmotors which do not conform to the efficiency standard are prohibited for import. This requires all gearmotors to be high efficiency. (Subject capacity: 1-200HP; frame: IEC 90 or larger; voltage: 600V or less; for constant-speed motors).

Canada: Natural Resources Canada (NRCan) enacted the Energy Efficiency Act (EEAct) in 1992 and the Energy Efficiency Regulation (EER) in 1995. These regulations are applied to standard motors imported to Canada starting February 3, 1995. Additional regulations were applied to gearmotors and explosion-proof motors imported after November 27, 1999. Motors and gearmotors which do not conform to the efficiency standard are prohibited for import. This requires all gearmotors to be high efficiency. (Subject capacity: 1-200HP; frame: IEC 90 or larger; voltage: 600V or less; for constant-speed motors).

Japan: Law concerning the Rational Use of Energy (comprehensive law promoting efficient energy use and energy waste elimination) was enacted in 1997 and "Reduction of annual energy consumption at factories by 1% on average" was announced. Furthermore, "Promotion on systematic energy-saving investment" and "Expansion of object factories and offices" were revised in April 1999. Use of high efficiency motor is recommended for the factory owners.

2. Standards

UL Standards: (US) Safety standards required primarily in the US. In the US, this standard is most generally applied to motored machines and is frequently quoted during negotiations for import. UL standards assure safety of equipment, appliances, and materials in order to protect human life and assets from fire and other accidents. UL conformity products are recommended also for observing the Product Liability (PL) Law.

CSA Standards: (Canada) Safety standards required in Canada. This is an arbitrary standards developed voluntarily by the members of association. However, most of the standards have been adopted officially as Canadian national standards and are quoted in laws and ordinances by the federal and state government and other local authorities. The CSA standards adopted as the Canadian national standards prefix with "CAN," followed with the number, for differentiation (Ex. CAN/CSA C22.1).

JIS: (Japan) Technical reference organized by Japan Electrical Manufacturers' Association (JEMA) has been applied previously. In July 2000, standard for high efficiency motors, "Low-voltage three-phase squirrel-cage high efficiency induction motors, JIS C 4212" was added in Japanese Industrial Standards (JIS).

GEARMOTORS WITH HIGH EFFICIENCY MOTORS

Table of Models

Combinations with 4P Motor **Reduction Ratio 6~273**

Reduction Ratio		6	8	11	13	15	17	21	25	29	35	43	51	59	71	87	119	104 (13 × 8)	121 (11 × 11)	143 (13 × 11)	165 (15 × 11)	195 (15 × 13)	231 (21 × 11)	273 (21 × 13)	
Output Speed r/min	50Hz	242	181	132	112	96.7	85.3	69.0	58.0	50.0	41.4	33.7	28.4	24.6	20.4	16.7	12.2	13.9	12.0	10.1	8.79	7.44	6.28	5.31	
	60Hz	292	219	159	135	117	103	83.3	70.0	60.3	50.0	40.7	34.3	29.7	24.6	20.1	14.7	16.8	14.5	12.2	10.6	8.97	7.58	6.41	
Motor (kW × P)	0.2 × 4	●	●	●	●	●	●	●	●	●	●	●	●	●	●	●	●	●	●	●	●	●	●	●	●
	0.4 × 4	●	●	●	●	●	●	●	●	●	●	●	●	●	●	●	●	●	●	●	●	●	●	●	●
	0.75 × 4	●	●	●	●	●	●	●	●	●	●	●	●	●	●	●	●	●	●	●	●	●	●	●	●
	1.5 × 4	●	●	●	●	●	●	●	●	●	●	●	●	●	●	●	●	●	●	●	●	●	●	●	●
	2.2 × 4	●	●	●	●	●	●	●	●	●	●	●	●	●	●	●	●	●	●	●	●	●	●	●	●
	3.7 × 4	●	●	●	●	●	●	●	●	●	●	●	●	●	●	●	●	●	●	●	●	●	●	●	●
	5.5 × 4	●	●	●	●	●	●	●	●	●	●	●	●	●	●	●	●	●	●	●	●	●	●	●	●
	7.5 × 4	●	●	●	●	●	●	●	●	●	●	●	●	●	●	●	●	●	●	●	●	●	●	●	●
	11 × 4	●	●	●	●	●	●	●	●	●	●	●	●	●	●	●	●	●	●	●	●	●	●	●	●
	15 × 4	●	●	●	●	●	●	●	●	●	●	●	●	●	●	●	●	●	●	●	●	●	●	●	●
	18.5 × 4	●	●	●	●	●	●	●	●	●	●	●	●	●	●	●	●	●	●	●	●	●	●	●	●
	22 × 4	●	●	●	●	●	●	●	●	●	●	●	●	●	●	●	●	●	●	●	●	●	●	●	●
30 × 4	●	●	●	●	●	●	●	●	●	●	●	●	●	●	●	●	●	●	●	●	●	●	●	●	

*Consult us for 6000SK Series (Reduction Ratio 2.5~10).

CYCLO® GEARMOTORS with High Efficiency Motor

High Efficiency Motor

Table E-1 3-Phase Induction Motor without Built-in Brakes

⊙: Standard Type ○: Produced on order

Specification		Indoor type (IP44)	Outdoor type (IP44)	Insulation class		
Output (kW)	Poles			E	B	F
		4	4	4	4	4
0.2		⊙	○	⊙	○	○
0.4		⊙	○	⊙	○	○
0.75		⊙	○		⊙	○
1.5		⊙	○		⊙	○
2.2		⊙	○		⊙	○
3.7		⊙	○		⊙	○
5.5		⊙	○		⊙	○
7.5		⊙	○		⊙	○
11		⊙	○		⊙	○
15		⊙	○		⊙	○
18.5		⊙	○		⊙	○
22		⊙	○		⊙	○
30		⊙	○		⊙	○
Remarks	Continuous rating, power source specification 200V 50/60Hz, 220V 60Hz (400V 50/60Hz, 440V 60Hz)					

Table E-2 3-Phase Induction Motor with Built-in Brakes

⊙: Standard Type ○: Produced on order

Specification		Indoor type (IP44)	Outdoor type (IP44)	Insulation class		
Output (kW)	Poles			E	B	F
		4	4	4	4	4
0.2		⊙	○	⊙	○	○
0.4		⊙	○	⊙	○	○
0.75		⊙	○		⊙	○
1.5		⊙	○		⊙	○
2.2		⊙	○		⊙	○
3.7		⊙	○		⊙	○
5.5		⊙	○		⊙	○
7.5		⊙	○		⊙	○
11		⊙	○		⊙	○
15		⊙	○		⊙	○
18.5		⊙	○		⊙	○
22		⊙	○		⊙	○
30		⊙	○		⊙	○
Remarks	Continuous rating, power source specification 200V 50/60Hz, 220V 60Hz (400V 50/60Hz, 440V 60Hz)					

- Note:
1. Consult us for specifications not indicated in above tables. They may be produced on order. Characteristics, dimension, and CYCLO® DRIVE combinations may be changed depending on the specification. Example: 6P, special voltage, dust-proof type, humidity-proof, tropical treatment, high-temperature use, double shaft extension (round or square shaft), EPAct conformity, NRCan conformity, etc.
 2. Consult us with information on operation condition (ambient temperature, input speed, mounting style, load condition, etc.) when driving our high-efficiency motor with inverter. CYCLO® DRIVE combination selection requires contemplation on startup, lubrication, thermal rating, etc.
 3. Consult us when driving our high-efficiency motor with high carrier frequency type (IGBT, etc.) at high input voltage (400V and above) or with long wiring distance. Motor insulation may be necessary.
 4. Protection nomenclature for outdoor type is IP44. Consult us for operation in locations with exposure to elements or with frequent water splash.

M E M O

GEARMOTORS WITH HIGH
EFFICIENCY MOTORS

A large grid of graph paper for taking notes, consisting of 20 columns and 40 rows of small squares.

F

TECHNICAL DATA

	Page
1. Reducer	
Mechanism	F-3
Lubrication	F-4
Nameplate	F-8
Allowable Radial and Axial Load	F-10
Moment of Inertia (GD ²)	F-17
Construction Drawing	F-25
Detailed Dimension of Slow Speed Shaft	F-28
2. Motor	
Terminal Box Specifications	F-32
Characteristics for Global Motor	F-36
Characteristics for Japan Standard Motor	F-38
Specification and Constructions of Built-in Brake	F-40
Connection	F-44
Example of Connection	F-45
Protection and Cooling	F-56
International Standards and Compliance of Sumitomo Products	F-57
EC Directives and CE Marking	F-60
International Power Source Voltage and Conditions	F-62
3. Common	
Paint and Rustproof Coating	F-64
Drive System Formulas	F-66
Reference Materials	F-66

F TECHNICAL DATA

1. Reducer

TECHNICAL
DATA

Reducer

Mechanism

The reducer portion of the CYCLO® GEARMOTOR is fundamentally different in principle and mechanism from the involute gearing mechanism of competitor's gearmotors. Our unique speed reducer part is an ingenious combination of the following two mechanisms:

- A combination of a planet gear and a fixed internal sun gear. In the CYCLO GEARMOTOR, the planet gear has cycloidal-shaped teeth and the sun gear has circular pin teeth. The number of teeth in the planet gear is one or two less than the sun gear.
- A constant speed internal gearing mechanism.

See Fig.F-1

In equation 1 below, P identifies the number of the planet gear teeth, S that of the sun gear, and ω2 the angular velocity of the planet gear around its own axis. The velocity ratio of ω2 to ω1 is shown as follows:

$$\frac{\omega_2}{\omega_1} = 1 - \frac{S}{P} = - \frac{S-P}{P} \dots \text{Equation 1}$$

With S greater by one or two than P in this equation, the highest velocity ratio is obtainable. That is, if S-P=1 is applied to Equation 1, the velocity ratio may be calculated from the following equation:

$$\frac{\omega_2}{\omega_1} = \frac{1}{P} \dots \text{Equation 2}$$

Or if S-P=2 is applied to Equation 1, the velocity ratio may be calculated from the following equation:

$$\frac{\omega_2}{\omega_1} = \frac{2}{P} \dots \text{Equation 3}$$

As the crankshaft rotates at the angular velocity ω1 around the axis of the sun gear, the planet gear rotates at the angular velocity:

$$- \frac{1\omega_1}{P} \text{ or } - \frac{2\omega_1}{P}$$

When P indicates the number of the teeth of the planet gear and the symbol 'ω' indicates that the rotation of the planet gear is in a reverse direction to that of the crankshaft.

In the CYCLO® GEARMOTOR, illustrated in Fig.F-2, circular teeth (pins) are adapted for the sun gear and epitrochoid curved teeth for the planet gear, thereby avoiding tooth top interference. The rotation of the planet gear around its own axis is taken out through a constant speed internal gearing mechanism as shown in Fig.F-3.

In this mechanism shown in Fig.F-4, the pins of the slow speed shaft are evenly spaced on a circle that is concentric to the axis of the sun gear. The pins transmit the rotation of the planet gear by rolling internally on the circumference of the bores of each planet gear or cycloid disc. The diameter of the bores minus the diameter of the slow speed shaft pins is equal to twice the eccentricity value of the crank shaft (eccentric). This mechanism smoothly transmits only the rotation of the planet gear around its own axis to the slow speed shaft.

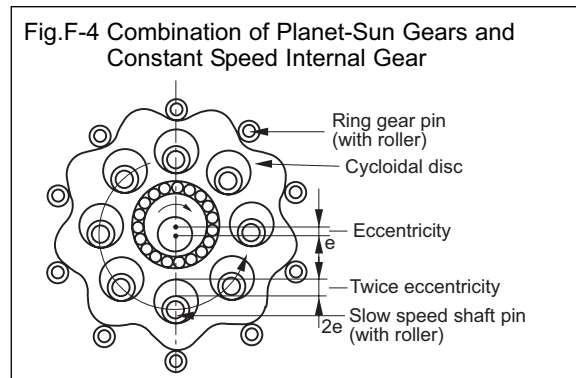
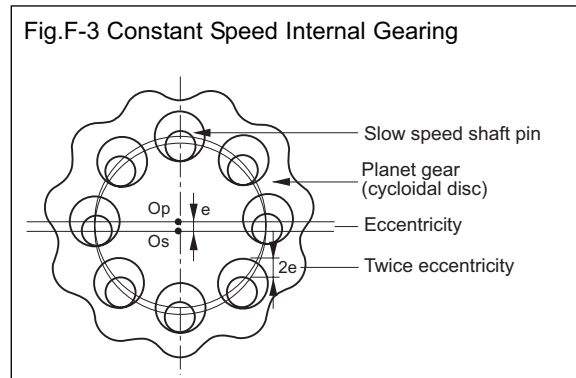
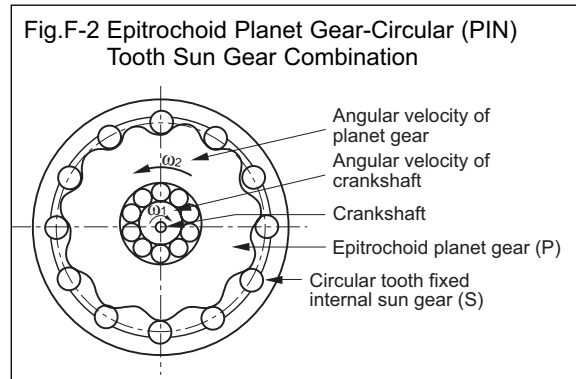
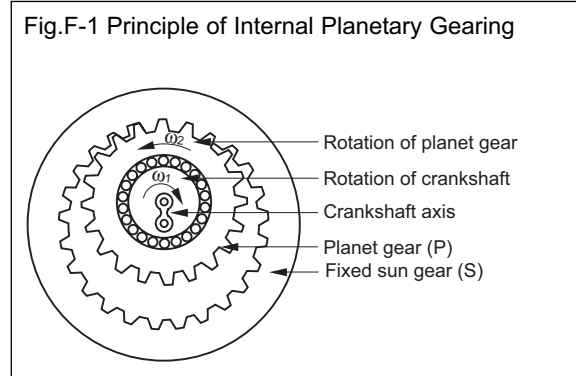

TECHNICAL DATA

Reducer

Lubrication

Lubrication Method

1. □ indicates 0, 5, or H (for certain frame size)

(1) Standard Type

Table F-1 Horizontal

a) 6000SK Series Horizontal

Nominal Reduction Ratio	2.5	3	4	5	6	8	10
Frame Size	Maintenance-Free Type Grease (MF) *Indication necessary for mounting direction.						
607□SK, 608□SK							
609□SK, 610□SK							
611□SK							
611□SK							

b) 6000 Series Single Reduction Horizontal

Ratio	6	8	11	13	15	17	21	25	29	35	43	51	59	71	87	119
Frame Size	Maintenance-Free Type Grease (MF)															
606□																
607□																
608□																
609□, 610□																
611□, 612□																
613□, 614□																
616□, 617□																
618□, 619□																
6205, 6215																
6225, 6235	Oil Bath (PB)															
6245, 6255	Oil Bath (PB)															
6265	Oil Bath (PB)															
6275	Oil Bath (PB)															

c) 6000 Series Double Reduction Horizontal

Ratio	104	121	143	165	195	231	273	319	377	473	599	649	731	841	1003	1015	1247	1479	1849	2065	2537	3045	3481	4437	5133	6177	7569		
Frame Size	Maintenance-Free Type Grease (MF)																												
606□DA																													
607□DA																													
609□DA, 610□DA																													
612□DA, 612□DB																													
613□DA, 613□DB																													
613□DC																													
614□DA, 614□DB																													
614□DC																													
616□DA, 616□DB																													
617□DA, 617□DB	Grease (G)																												
618□DA	Grease (G)																												
616□DC	Grease (G)																												
617□DC	Grease (G)																												
618□DB	Grease (G)																												
619□DA, 619□DB	Oil Bath (PB)																												
6205DA, 6205DB	Oil Bath (PB)																												
6215DA, 6215DB	Oil Bath (PB)																												
6225DA, 6225DB	Oil Bath (PB)																												
6235DA, 6235DB	Oil Bath (PB)																												
6245DA, 6245DB	Oil Bath (PB)																												
6255DA, 6255DB	Oil Bath (PB)																												
6265DA	Oil Bath (PB)																												
6275DA	Oil Bath (PB)																												

Note: 1. This table shows the standard lubrication method when the CYCLO® DRIVE is driven at the standard input speed.
 2. Grease lubrication is possible for some models with oil lubrication as standards. Consult us in those cases, for performance may vary.
 3. □ indicates 0 or 5, expressing the combination with reduction ratio.

TECHNICAL DATA
Reducer

Lubrication

Table F-2 Vertical

a) 6000SK Series Vertical

Nominal Reduction Ratio		2.5	3	4	5	6	8	10	
		Frame Size							
607□SK,	608□SK	Maintenance-Free Type Grease (MF) *Indication necessary for mounting direction.							
609□SK,	610□SK								
611□SK									

b) 6000 Series Single Reduction Vertical

Ratio	Frame Size																
	6	8	11	13	15	17	21	25	29	35	43	51	59	71	87	119	
606□	Maintenance-Free Type Grease (MF)											43	Oil Bath (PB)				
607□												59					
608□												87					
609□, 610□																	
611□, 612□																	
613□, 614□	Forced Oil Lubrication (P)																
616□, 617□																	
618□, 619□																	
6205, 6215																	
6225, 6235																	
6245, 6255																	
6265																	
6275									TP		TP		TP		TP		

TP: Positive Displacement Pump Lubrication (See Table F-3)

c) 6000 Series Double Reduction Vertical

Ratio	Frame Size																									
	104	121	143	165	195	231	273	319	377	473	599	649	731	841	1003	1015	1247	1479	1849	2065	2537	3045	3481	4437	5133	6177
606□DA	Maintenance-Free Type Grease (MF)																									
607□DA																										
609□DA, 610□DA																										
612□DA, 612□DB																										
613□DA, 613□DB																										
613□DC	Grease (G)																									
614□DA, 614□DB																										
614□DC																										
616□DA, 616□DB																										
617□DA, 617□DB																										
618□DA																										
616□DC																									473	
617□DC																									841	
618□DB																									1015	
619□DA, 619□DB																									2065	
6205DA, 6205DB	121	165	Forced Oil Lubrication (P)																		1849	2537				
6215DA, 6215DB																										
6225DA, 6225DB																										
6235DA, 6235DB																										
6245DA, 6245DB																										
6255DA, 6255DB																										
6265DA																										
6275DA	377	Positive Displacement Pump Lubrication (TP) (See Table F-3)																								

TECHNICAL DATA
Reducer

Note: 1. This table shows the standard lubrication method when the CYCLO® DRIVE is driven at the standard input speed.
2. Grease lubrication is possible for some models with oil lubrication as standards. Consult us in those cases, for performance may vary.
3. □ indicates 0 or 5, expressing the combination with reduction ratio.

Lubrication

(2) Electric Pump (Electric Pump Type Forced Oil Lubrication Specification)

Table F-3 Electric Pump Specification

Trochoid pump type	TOP216HA-VB3 with release valve	TOP204HB-VB3 with release valve
	(3-phase induction motor: 0.75kW × 4P Type E)	(3-phase induction motor: 0.4kW × 4P Type E)
Frame size/ reduction ratio	6275/29, 43, 59, 87	6275DA

Note: Although the CYCLO® SPEED REDUCER is capable for most uses with lubrication method in Table F-1 and 2, consult us when using in severe conditions, such as with harsh ambient temperature, input speed, or load condition.

2. Lubricant

(1) Grease Lubrication Models

Grease lubrication models in Table F-4 are packed with grease prior to shipment. They may be used without replenishment.

(i) Maintenance-Free Series

· 6000SK Series

Models in Table F-1 (a) and F-2 (a) are sealed with long-life grease (ALVANIA GREASE EPR000). Although replenishment is hardly necessary, replacement every 20,000 hours or 4~5 years will provide longer lifetime.

*Only designated mounting direction possible.

· 6000 Series

Models in section (MF) in Table F-1 (b) & (c) and F-2 (b) & (c) are sealed with long-life grease (BEN-10 No.2). Although replenishment is hardly necessary, replacement every 20,000 hours or 4~5 years will provide longer lifetime.

*Any mounting direction possible.

(ii) Grease Lubrication Models Other than Indicated in Section (i)

Replenish or replace grease following the Instruction Manual.

Table F-4 Standard Grease

Model	Ambient Temperature [°C]	Model/Part	Company	Brand	
CYCLO® 6000SK Series	-10 ~ 40	(i) Maintenance-Free Type Grease Lubrication	Shell Oil	ALVANIA GREASE EPR000	
CYCLO® 6000 Series	-10 ~ 50	(i) Maintenance-Free Type Grease Lubrication	Nippon Koyu	BEN-10 No.2	
		(ii) Models other than (i)	Cosmo Oil	COSMO GREASE DYNAMAX SH No.2	
Sumitomo Motor	-10 ~ 50	Sealed Bearings		Kyodo Yushi	MULTEMP SRL
		Open Bearings	Thermal Class: E, B	Exxon Mobil	UNIREX N2
			Thermal Class: F	Shell Oil	DARINA GREASE 2

(iii) Consult us when the unit is stored for more than three years. Grease replacement may be necessary.

Note: 1. Do not use grease other than the ones indicated above.
2. Models (ii) in the Table F-4 are packed with COSMO GREASE DYNAMAX SH No.2 prior to shipment.
3. Grease for models (ii) in Table F-4 may be combined with no problem.
4. Consult us when the unit will be operated in temperatures exceeding 0~40°C.

Lubrication

(2) Oil Lubrication Models

Oil lubrication models are shipped without oil. Always fill with lubrication oil to the top red line on the oil gauge before operation.

Table F-5 Recommended Lubrication Oil (SP Type Industrial Extreme-Pressure Gear Oil)
[Equivalent to Type 2 Industrial Oil in JIS K2219.]

Ambient temperature °C	Gulf Oil	Esso Oil	Mobil Oil	Shell Oil	Caltex Oil	BP Oil
-10~5	EP Lubricant HD 68	Spartan EP 68	Mobil gear 626 (ISO VG 68)	Omala Oil 68		Energol GR-XP 68
0 ~ 35	EP Lubricant HD 100 HD 150	Spartan EP 100 EP 150	Mobil gear 627, 629 (ISO VG 100, 150)	Omala Oil 100, 150	Meropa 100, 150	Energol GR-XP 100 GR-XP 150
30 ~ 50	EP Lubricant HD 220 HD 320 HD 460	Spartan EP 220 EP 320 EP 460	Mobil gear 630, 632 633, 634 (ISO VG 220~460)	Omala Oil 220, 320 460	Meropa 220, 320 460	Energol GR-XP 220 GR-XP 320 GR-XP 460

Note: 1. Use oil with lower viscosity for operation in winter or relatively low ambient temperature, specified in the parenthesis.
2. Consult us for operation in ambient temperatures exceeding 0~40°C.

2. Volume of Oil

Table F-6 Volume of Lubrication Oil, Litres ℓ (Approximate)

[Single Reduction]

Frame Size	613□	614□	616□	617□	618□	619□	6205	6215	6225	6235	6245	6255	6265	6275
Horizontal	0.7	0.7	1.4	1.9	2.5	4.0	5.5	8.5	10	15	16	21	29	56
Vertical	1.1	1.1	1	1.9	2	2.7	5.7	7.5	10	12	15	42	51	(60)

[Double Reduction]

Frame Size	616□	617□	618□	619□	619□	6205	6205	6215	6215	6225	6225	6235	6235	6245	6245	6255	6255	6265	6275
	DC	DC	DB	DA	DB	DA	DB	DA	DB	DA	DB	DA	DB	DA	DB	DA	DB	DA	DA
Horizontal	1.5	2.4	3.5	5.8	6.0	6.0	6	10	10	11	11	17	17	18	18	23	23	32	60
Vertical	1.0	1.9	2.0	2.7	2.7	11	11	14	14	18	18	23	23	29	29	42	42	51	(60)

Note: 1. □ indicates 0, 5, or H (for certain frame size).
2. () with trochoid pump.

3. Cautions on Oil Seals

Oil seal has limited lifetime. Sealing effect may lower by natural degradation or abrasion by prolonged use. Seal life may vary depending on operation condition and ambient condition of the reducer. Oil seal change every 1~3 years is recommended for normal operation (uniform load, 10 hours/day, at normal temperature).

Nameplate

There are two types of nameplates, Type I and Type II. Refer to the relevant example of the typical plates shown below.

1. For Gearmotors

(1) Nameplate Type I: Gearmotor

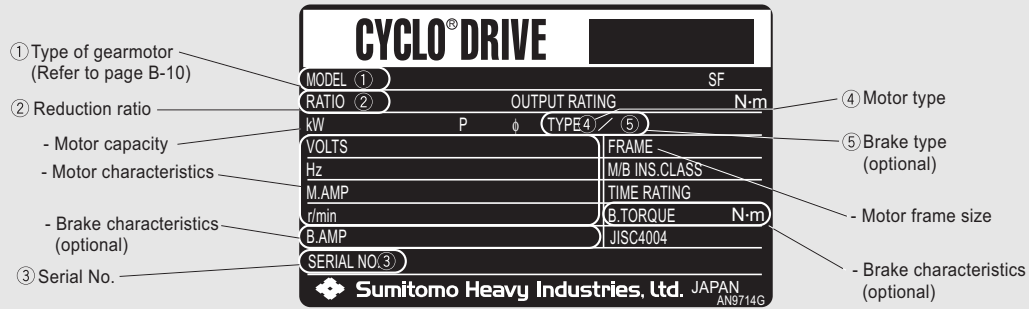

Fig. F-5 Nameplate of Gearmotor (Type I)

(2) Nameplate Type II: Reducer with Motor

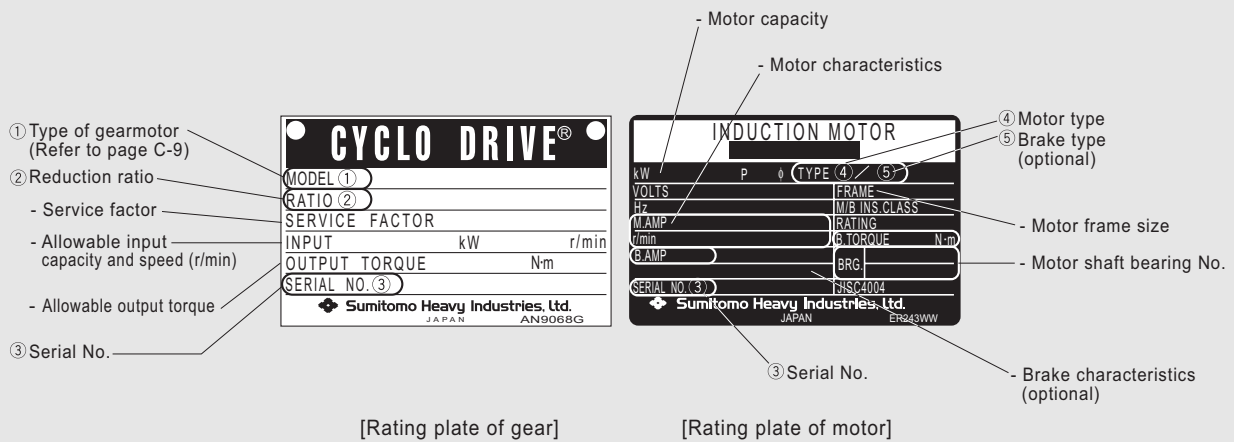

Fig. F-6 Namplates of Reducer with Motor (Type II)

TECHNICAL DATA

Reducer

Nameplate

2. For Reducers

(1) Nameplate Type I

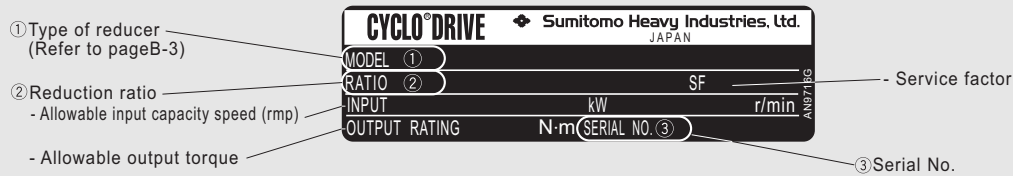

Fig. F-7 Nameplate of Reducer (Type I)

(2) Nameplate Type II

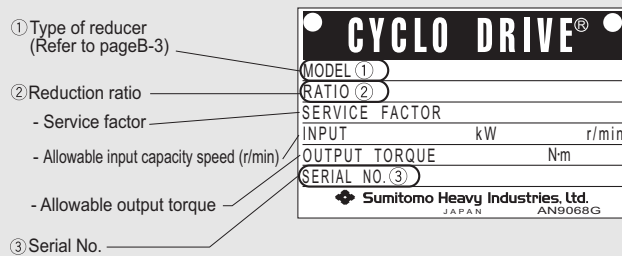

Fig. F-8 Nameplate of Reducer (Type II)

Allowable Radial and Axial Load

Use within the allowable range for the radial and axial load when a gear or a pulley is coupled with CYCLO® reducer.

1. Radial and Axial Load on the Slow Speed Shaft

Confirm the radial axial load on the slow speed shaft using the following formula:

1) Radial load P_r

$$P_r = \frac{T_\ell}{R} \leq \frac{P_{ro}}{L_f \cdot C_f \cdot F_s} \quad [\text{N, kgf}]$$

2) Axial load P_a

$$P_a \leq \frac{P_{ao}}{C_f \cdot F_s} \quad [\text{N, kgf}]$$

3) When radial and axial load co-exist.

$$\left(\frac{P_r \cdot L_f}{P_{ro}} + \frac{P_a}{P_{ao}} \right) \cdot C_f \cdot F_s \leq 1$$

P_r : Actual radial load [N, kgf]

T_ℓ : Actual transmitted torque [N·m, kgf·m] on slow speed shaft of the reducer.

R : Pitch circle radius [m] of sprocket, gear, pulley, etc.

P_{ro} : Allowable radial load [N, kgf] (Refer to Selection Table)

P_a : Actual axial load [N, kgf]

P_{ao} : Allowable axial load [N, kgf] (Table E-10, 11)

L_f : Load location factor (Table E-9)

C_f : Coupling factor (Table E-7)

F_s : Shock factor (Table E-8)

- When the radial load exceeds the allowable values, a larger frame size may be selected, but depending upon the extent of the load, this may be avoided by using the heavy radial load type; please refer to Page E-12.
- Consult us when using for application with extremely high startup frequency.

Table E-7 Coupling Factor C_f

Coupling Method	C_f
Chain	1
Gears	1.25
V-Belt	1.5

Table E-8 Shock Factor F_s

Degree of Shock	F_s
Practically no shock	1
Light shock	1~1.2
Severe shock	1.4~1.6

Calculate detailed intermediate values in Tables E-9~E-11 according to the interpolation method.

Calculation Example by Interpolation Method

Load Location Factor

Frame size 6075 Load Location Factor for $L=18\text{mm}$ is calculated below.

$$1.00 + \frac{1.29-1.00}{20-15} \times (18-15) = 1.17$$

Thrust Load Capacity

Frame size 6180 Thrust Load Capacity for output speed 130r/min is calculated bellow.

$$12500 + \frac{13100-12500}{150-125} \times (150-130) = 12980 \text{ [N]}$$

Allowable Radial and Axial Load

Table F-9 Load Location Factor (Slow Speed Shaft) Lf

Frame Size		Load Location L mm																											
Single Reduction	Double Reduction	~5	10	15	20	25	30	35	40	45	50	60	70	80	90	100	120	140	160	180	200	225	250	275	300				
607□SK	-	0.83	0.92	1.00	1.08	1.17	1.25	-	-	-	-	-	-	-	-	-	-	-	-	-	-	-	-	-	-	-			
608□SK	-	0.83	0.90	0.97	1.03	1.10	1.17	1.24	-	-	-	-	-	-	-	-	-	-	-	-	-	-	-	-	-	-			
609□SK	-	0.87	0.92	0.97	1.03	1.08	1.13	1.19	-	-	-	-	-	-	-	-	-	-	-	-	-	-	-	-	-	-			
610□SK	-	0.87	0.92	0.97	1.03	1.08	1.13	1.19	-	-	-	-	-	-	-	-	-	-	-	-	-	-	-	-	-	-			
611□SK	-	0.83	0.88	0.93	0.98	1.02	1.07	1.12	1.17	1.22	-	-	-	-	-	-	-	-	-	-	-	-	-	-	-	-			
606□	606□DA	0.83	0.94	1.19	1.56	-	-	-	-	-	-	-	-	-	-	-	-	-	-	-	-	-	-	-	-	-			
607□	607□DA	0.82	0.91	1.00	1.29	1.59	1.88	-	-	-	-	-	-	-	-	-	-	-	-	-	-	-	-	-	-	-			
608□	-	0.81	0.87	0.94	1.03	1.28	1.54	1.80	-	-	-	-	-	-	-	-	-	-	-	-	-	-	-	-	-	-			
609□	609□DA	0.86	0.92	0.97	1.13	1.38	1.64	1.90	-	-	-	-	-	-	-	-	-	-	-	-	-	-	-	-	-	-			
610□	610□DA	0.86	0.92	0.97	1.13	1.38	1.64	1.90	-	-	-	-	-	-	-	-	-	-	-	-	-	-	-	-	-	-			
611□	-	0.78	0.84	0.90	0.96	1.02	1.08	1.19	1.36	1.53	-	-	-	-	-	-	-	-	-	-	-	-	-	-	-	-			
612□	612□DA 612□DB	-	0.82	0.87	0.92	0.97	1.08	1.25	1.42	1.59	1.76	-	-	-	-	-	-	-	-	-	-	-	-	-	-	-			
613□	613□DA 613□DB 613□DC	-	-	0.83	0.87	0.92	0.96	1.00	1.13	1.25	1.38	1.63	1.88	-	-	-	-	-	-	-	-	-	-	-	-	-			
614□	614□DA 614□DB 614□DC	-	-	-	0.66	0.73	0.80	0.87	0.93	1.00	1.10	1.30	1.50	1.70	1.90	-	-	-	-	-	-	-	-	-	-	-			
616□	616□DA 616□DB 616□DC	-	-	-	0.83	0.87	0.90	0.93	0.97	1.00	1.11	1.32	1.53	1.75	1.96	-	-	-	-	-	-	-	-	-	-	-			
617□	617□DA 617□DB 617□DC	-	-	-	0.86	0.89	0.92	0.94	0.97	1.00	1.11	1.32	1.53	1.75	1.96	-	-	-	-	-	-	-	-	-	-	-			
618□	618□DA 618□DB	-	-	-	-	0.85	0.87	0.90	0.93	0.95	0.98	1.09	1.26	1.43	1.60	1.78	-	-	-	-	-	-	-	-	-	-			
619□	619□DA 619□DB	-	-	-	-	-	0.85	0.87	0.89	0.91	0.93	0.97	1.04	1.18	1.32	1.46	1.75	-	-	-	-	-	-	-	-	-			
6205	6205DA 6205DB	-	-	-	-	-	-	-	0.70	0.74	0.77	0.84	0.91	0.98	1.05	1.12	1.26	1.40	1.54	-	-	-	-	-	-	-			
6215	6215DA 6215DB	-	-	-	-	-	-	-	0.70	0.73	0.77	0.84	0.91	0.98	1.05	1.13	1.27	1.41	1.56	-	-	-	-	-	-	-			
6225	6225DA 6225DB	-	-	-	-	-	-	-	0.86	0.88	0.90	0.93	0.96	0.99	1.02	1.06	1.12	1.19	1.25	-	-	-	-	-	-	-			
6235	6235DA 6235DB	-	-	-	-	-	-	-	0.82	0.84	0.85	0.88	0.91	0.94	0.97	1.00	1.06	1.12	1.18	1.24	1.30	-	-	-	-	-			
6245	6245DA 6245DB	-	-	-	-	-	-	-	0.83	0.84	0.86	0.89	0.92	0.94	0.97	1.00	1.06	1.11	1.17	1.23	1.29	-	-	-	-	-			
6255	6255DA 6255DB	-	-	-	-	-	-	-	-	0.83	0.85	0.88	0.90	0.93	0.95	1.00	1.05	1.10	1.22	1.36	1.52	1.69	-	-	-	-			
6265	6265DA	-	-	-	-	-	-	-	-	-	-	-	0.83	0.85	0.88	0.90	0.94	0.98	1.04	1.17	1.29	1.45	1.61	1.77	1.93				
6275	6275DA	-	-	-	-	-	-	-	-	-	-	-	-	0.67	0.71	0.75	0.82	0.90	0.98	1.09	1.21	1.35	1.50	1.65	1.79				
Single Reduction	Double Reduction	~5	10	15	20	25	30	35	40	45	50	60	70	80	90	100	120	140	160	180	200	225	250	275	300				
Frame Size		Load Location L mm																											

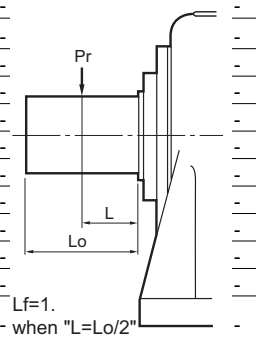

TECHNICAL DATA
Reducer

Note: □ indicates 0 or 5, expressing combination with reduction ratio.

Allowable Radial and Axial Load

Table F-10 Axial Load Capacity (Slow Speed Shaft) Pao (Upper Row: N, Lower Row: kgf)

(When Cf, Lf, Fs=1)

Frame Size		Output Speed r/min																
Single Reduction	Double Reduction	~10	15	20	25	30	35	40	50	60	80	100	125	150	200	250	300	~700
607□SK	-	785	785	785	785	785	785	785	785	785	785	785	785	785	785	785	785	785
608□SK	-	981	981	981	981	981	981	981	981	981	981	981	981	981	981	981	981	981
609□SK	-	981	981	981	981	981	981	981	981	981	981	981	981	981	981	981	981	981
610□SK	-	1470	1470	1470	1470	1470	1470	1470	1470	1470	1470	1470	1470	1470	1470	1470	1470	1470
611□SK	-	1470	1470	1470	1470	1470	1470	1470	1470	1470	1470	1470	1470	1470	1470	1470	1470	1470
606□	606□DA	294	294	294	294	294	294	294	294	294	294	294	294	294	294	-	-	
607□	607□DA	785	785	785	785	785	785	785	785	785	785	785	785	785	785	785	785	
608□	-	981	981	981	981	981	981	981	981	981	981	981	981	981	981	981	981	
609□	609□DA	981	981	981	981	981	981	981	981	981	981	981	981	981	981	981	981	
610□	610□DA	1470	1470	1470	1470	1470	1470	1470	1470	1470	1470	1470	1470	1470	1470	1470	1470	
611□	-	1470	1470	1470	1470	1470	1470	1470	1470	1470	1470	1470	1470	1470	1470	1470	1470	
612□	612□DA	2940	2940	2940	2940	2940	2940	2940	2940	2940	2940	2940	2940	2940	2770	2500	2390	
613□	613□DA	3920	3920	3920	3920	3920	3920	3920	3920	3920	3920	3920	3920	3920	3920	3920	3920	
614□	614□DA	5400	5400	5400	5400	5400	5400	5400	5400	5400	5230	4860	4560	4370	3850	3670	3450	
616□	616□DA	6870	6870	6870	6870	6870	6870	6870	6870	6870	6870	6870	6870	6870	6300	5700	-	
617□	617□DA	9810	9810	9810	9810	9810	9810	9810	9810	9810	9810	9810	9680	9020	8090	7330	6880	
618□	618□DA	13700	13700	13700	13700	13700	13700	13700	13700	13700	13700	13700	13100	12500	11000	-	-	
619□	619□DA	19600	19600	19600	19600	19600	19600	19600	19600	19600	19600	19600	18500	17500	15400	-	-	
6205	6205DA	26500	23500	21100	19600	18600	18100	17700	16700	15700	14200	13200	12800	12300	11300	-	-	
6215	6215DA	27500	24500	22100	20600	19600	18600	18100	17200	16200	14700	13700	13200	12800	11800	-	-	
6225	6225DA	29400	25600	23200	21700	20600	19600	18700	17600	16700	15300	14400	13600	13100	12100	-	-	
6235	6235DA	35300	31400	28400	26500	25000	23500	22600	21100	20100	18600	17700	16700	-	-	-	-	
6245	6245DA	37300	33800	30900	28800	27300	26100	25100	23500	22300	21000	19900	19100	-	-	-	-	
6255	6255DA	48100	43100	39400	36900	35100	33600	32300	30400	28500	26800	25500	24200	-	-	-	-	
6265	6265DA	52000	52000	51000	47500	44800	42800	41600	38900	37300	34800	33000	31100	-	-	-	-	
6275	6275DA	58900	58900	58900	58900	58900	58900	58900	58900	-	-	-	-	-	-	-	-	
Single Reduction	Double Reduction	~10	15	20	25	30	35	40	50	60	80	100	125	150	200	250	300	
Frame Size		Output Speed r/min																

Note: □ indicates 0 or 5, expressing combination with reduction ratio.

TECHNICAL DATA
Reducer

Allowable Radial and Axial Load

2. Heavy Radial Load Type, Light Heavy Radial Load Type (Optional Items)

When the radial load of the slow speed shaft exceeds the allowable value of the standard CYCLO® reducer, a larger frame size may be selected, but depending upon the degree of the load, this may be avoided by using the heavy radial load type. Refer to Table F-9~10 for allowable radial load on the slow speed shaft of the heavy radial load type.

Precautions for Selection and Use

1. Heavy radial load type is indicated with the suffix "R1" or "R2" after the frame size.
Example: CHHM5-6135-R2-B-29
2. □ indicates 0, 5, or H.
3. Consult us for the following conditions, which require special considerations:
 - When the shaft direction is vertical (Vertical type).
 - When thrust load is simultaneously exerted on the slow speed shaft.
4. Use JIS B1051 erection bolts, with strength in exceeding 8.8.

Table F-11 Allowable Radial Load Pro (Upper: N, Lower: kgf, Max) on the Slow Speed Shaft of the Light Heavy Radial Load Type.

(When Cf, Lf, Fs=1)

Frame Size		Output Speed r/min											
Single Reduction	Double Reduction	~1	2	3	4	5	6	8	10	15	20	25	30
613□	613□DA	14700	14700	14700	14700	14700	14700	14700	14700	14700	14700	14700	14700
	613□DB	1500	1500	1500	1500	1500	1500	1500	1500	1500	1500	1500	1500
	613□DC												
616□	616□DA	22100	22100	22100	22100	22100	22100	22100	22100	22100	22100	22100	22100
	616□DB	2250	2250	2250	2250	2250	2250	2250	2250	2250	2250	2250	2250
	616□DC												
617□	617□DA	29500	29500	29500	29500	29500	29500	29500	29500	29500	29500	29500	29500
	617□DB	3010	3010	3010	3010	3010	3010	3010	3010	3010	3010	3010	3010
	617□DC												
618□	618□DA	41700	41700	41700	41700	41700	41700	41700	41700	41700	41700	41700	41700
	618□DB	4250	4250	4250	4250	4250	4250	4250	4250	4250	4250	4250	4250
619□	619□DA	59000	59000	59000	59000	59000	59000	59000	59000	59000	59000	59000	59000
	619□DB	6010	6010	6010	6010	6010	6010	6010	6010	6010	6010	6010	6010

Frame Size		Output Speed r/min										
Single Reduction	Double Reduction	35	40	50	60	80	100	125	150	200	250	300
613□	613□DA	14700	14700	14700	14700	14100	13500	12600	11900	10900	10200	9660
	613□DB	1500	1500	1500	1500	1440	1380	1280	1210	1110	1040	985
	613□DC											
616□	616□DA	22100	22100	22100	22100	22100	21600	20100	19000	17500	16300	15400
	616□DB	2250	2250	2250	2250	2250	2200	2050	1940	1780	1660	1570
	616□DC											
617□	617□DA	29500	29500	29500	29500	29500	29300	27400	25900	23800	22200	21100
	617□DB	3010	3010	3010	3010	3010	2990	2790	2640	2430	2260	2150
	617□DC											
618□	618□DA	41700	41700	41700	41700	41300	38600	36200	34200	31400	-	-
	618□DB	4250	4250	4250	4250	4210	3930	3690	3490	3200	-	-
619□	619□DA	59000	59000	55200	53000	47200	44000	41000	38300	34700	-	-
	619□DB	6010	6010	5630	5400	4810	4490	4180	3900	3540	-	-

Note: □ indicates 0 or 5, expressing combination with reduction ratio.

TECHNICAL
DATA

Reducer

Allowable Radial and Axial Load

Table F-12 Allowable Radial Load Pro (Upper: N, Lower: kgf, Max) on the Slow Speed Shaft of the Heavy Radial Load Type.

(Cf, Lf, Fs=1)

Frame Size		Output Speed r/min											
Single Reduction	Double Reduction	~1	2	3	4	5	6	8	10	15	20	25	30
613□	613□DA	24000	24000	24000	24000	24000	24000	24000	24000	23800	21800	20400	19300
	613□DB	2450	2450	2450	2450	2450	2450	2450	2450	2430	2220	2080	1970
	613□DC												
616□	616□DA	33600	33600	33600	33600	33600	33600	33600	33600	33600	33600	33300	31500
	616□DB	3430	3430	3430	3430	3430	3430	3430	3430	3430	3430	3390	3210
	616□DC												
617□	617□DA	45900	45900	45900	45900	45900	45900	45900	45900	45900	45900	45300	42900
	617□DB	4680	4680	4680	4680	4680	4680	4680	4680	4680	4680	4620	4370
	617□DC												
618□	618□DA	55700	55700	55700	55700	55700	55700	55700	55700	55700	55700	55700	55700
	618□DB	5680	5680	5680	5680	5680	5680	5680	5680	5680	5680	5680	5680
	618□DC												
619□	619□DA	71800	71800	71800	71800	71800	71800	71800	71800	71800	71800	71800	69300
	619□DB	7320	7320	7320	7320	7320	7320	7320	7320	7320	7320	7320	7060
	619□DC												
6205	6205DA	97800	97800	97800	97800	97800	97800	97800	97800	89100	81800	76500	72400
	6205DB	9970	9970	9970	9970	9970	9970	9970	9970	9080	8340	7800	7380
	6205DC												
6215	6215DA	132000	132000	132000	132000	126000	119000	109000	102000	90500	83000	77600	73500
	6215DB	13500	13500	13500	13500	12800	12100	11100	10400	9230	8460	7910	7490
	6215DC												
6225	6225DA	161000	161000	161000	161000	156000	148000	135000	126000	112000	103000	96300	91100
	6225DB	16400	16400	16400	16400	15900	15100	13800	12800	11400	10500	9820	9290
	6225DC												
6235	6235DA	183000	183000	183000	183000	183000	183000	170000	159000	141000	129000	121000	114000
	6235DB	18700	18700	18700	18700	18700	18700	17300	16200	14400	13100	12300	11600
	6235DC												
6245	6245DA	223000	223000	223000	223000	209000	198000	181000	169000	150000	138000	129000	122000
	6245DB	22700	22700	22700	22700	21300	20200	18500	17200	15300	14100	13100	12400
	6245DC												
6255	6255DA	274000	274000	274000	274000	258000	244000	224000	210000	185000	170000	159000	151000
	6255DB	27900	27900	27900	27900	26300	24900	22800	21400	18900	17300	16200	15400
	6255DC												
6265	6265DA	283000	283000	283000	283000	283000	283000	270000	253000	224000	205000	191000	181000
	6265DB	28800	28800	28800	28800	28800	28800	27500	25800	22800	20900	19500	18500
	6265DC												
6275	6275DA	272000	272000	272000	272000	272000	272000	272000	272000	272000	272000	272000	272000
	6275DB	27700	27700	27700	27700	27700	27700	27700	27700	27700	27700	27700	27700
	6275DC												

TECHNICAL DATA

Reducer

Frame Size		Output Speed r/min										
Single Reduction	Double Reduction	35	40	50	60	80	100	125	150	200	250	300
613□	613□DA	18400	17800	16500	15600	14400	13500	12600	11900	10900	10200	9660
	613□DB	1880	1810	1680	1590	1470	1380	1280	1210	1110	1040	985
	613□DC											
616□	616□DA	30100	28900	27000	25600	23500	22000	20500	19400	17900	16600	15400
	616□DB	3070	2950	2750	2610	2400	2240	2090	1980	1820	1690	1570
	616□DC											
617□	617□DA	40900	39300	36800	34800	31900	29900	27900	26400	24300	22200	21100
	617□DB	4170	4010	3750	3550	3250	3050	2840	2690	2480	2260	2150
	617□DC											
618□	618□DA	54000	51900	48500	45900	42100	39400	36900	34900	32000	-	-
	618□DB	5500	5290	4940	4680	4290	4020	3760	3560	3260	-	-
	618□DC											
619□	619□DA	66100	63500	59400	56300	51600	48300	45100	42800	39300	-	-
	619□DB	6740	6470	6060	5740	5260	4920	4600	4360	4010	-	-
	619□DC											
6205	6205DA	69100	66400	62100	58800	54000	50500	47100	44600	41000	-	-
	6205DB	7040	6770	6330	5990	5500	5150	4800	4550	4180	-	-
	6205DC											
6215	6215DA	70100	67400	63000	59600	54800	51300	47900	45400	41600	-	-
	6215DB	7150	6870	6420	6080	5590	5230	4880	4630	4240	-	-
	6215DC											
6225	6225DA	87000	83500	78100	74000	67900	63500	59400	56300	51500	-	-
	6225DB	8870	8510	7960	7540	6920	6470	6060	5740	5250	-	-
	6225DC											
6235	6235DA	109000	105000	98100	92900	85300	79800	74500	-	-	-	-
	6235DB	11100	10700	10000	9470	8700	8130	7590	-	-	-	-
	6235DC											
6245	6245DA	116000	112000	105000	98900	90800	84900	79400	-	-	-	-
	6245DB	11800	11400	10700	10100	9260	8650	8090	-	-	-	-
	6245DC											
6255	6255DA	144000	139000	129000	123000	112000	105000	98300	-	-	-	-
	6255DB	14700	14200	13100	12500	11400	10700	10000	-	-	-	-
	6255DC											
6265	6265DA	174000	166000	156000	148000	135000	126000	118000	-	-	-	-
	6265DB	17700	16900	15900	15100	13800	12800	12000	-	-	-	-
	6265DC											
6275	6275DA	-	-	-	-	-	-	-	-	-	-	-
	6275DB	-	-	-	-	-	-	-	-	-	-	-
	6275DC											

Note: □ indicates 0 or 5, expressing combination with reduction ratio.

Allowable Radial and Axial Load

Confirm the radial load on the high speed shaft, following the formula below:

$$Pr \leq \frac{Pro}{Lf \cdot Cf \cdot Fs} \text{ [N, kgf]}$$

- Pr: Actual radial load [N, kgf]
- Pro: Allowable radial load [N, kgf]
- Lf: Load location factor (Table F-11)
- Cf: Coupling factor (Table F-5)
- Fs: Shock factor (Table F-6)

Table F-13 Radial Load Location Factor (High Speed Shaft) Lf

Frame Size		Load Location L mm																			
Single Reduction	Double Reduction	5	10	15	20	25	30	35	40	45	50	60	70	80	90	100	120	140	160	180	200
607□SK	-	0.72	0.91	1.09	1.28	1.46	-	-	-	-	-	-	-	-	-	-	-	-	-	-	-
608□SK	-	0.90	0.97	1.03	1.10	1.16	-	-	-	-	-	-	-	-	-	-	-	-	-	-	-
609□SK	-	0.90	0.97	1.03	1.10	1.16	-	-	-	-	-	-	-	-	-	-	-	-	-	-	-
610□SK	-	0.75	0.92	1.08	1.25	1.42	-	-	-	-	-	-	-	-	-	-	-	-	-	-	-
611□SK	-	0.87	0.92	0.97	1.03	1.08	1.13	1.18	-	-	-	-	-	-	-	-	-	-	-	-	-
606□	606□DA, 607□DA	0.73	0.91	1.20	1.60	2.00	-	-	-	-	-	-	-	-	-	-	-	-	-	-	-
607□	609□DA, 610□DA, 612□DA, 613□DA, 614□DA	0.73	0.91	1.20	1.60	2.00	-	-	-	-	-	-	-	-	-	-	-	-	-	-	-
608□	-	0.73	0.91	1.20	1.60	2.00	-	-	-	-	-	-	-	-	-	-	-	-	-	-	-
609□	612□DB, 613□DB, 614□DB, 616□DA, 617□DA	0.88	0.96	1.20	1.59	2.00	2.38	-	-	-	-	-	-	-	-	-	-	-	-	-	-
610□	613□DC, 614□DC, 616□DB, 617□DB, 618□DA	0.91	0.97	1.20	1.59	2.00	2.38	-	-	-	-	-	-	-	-	-	-	-	-	-	-
611□	-	0.91	0.97	1.20	1.59	2.00	2.38	-	-	-	-	-	-	-	-	-	-	-	-	-	-
612□	616□DC, 617□DC, 619□DA, 6205DA	-	0.81	0.93	1.14	1.41	1.67	1.96	2.22	-	-	-	-	-	-	-	-	-	-	-	-
613□	618□DB, 619□DB, 6205DB, 6215DA, 6225DA	-	0.78	0.89	1.00	1.23	1.45	1.69	1.92	2.13	-	-	-	-	-	-	-	-	-	-	-
614□	-	-	0.78	0.89	1.00	1.23	1.45	1.69	1.92	2.13	-	-	-	-	-	-	-	-	-	-	-
616□	6215DB, 6235DA, 6245DA	-	0.92	0.95	0.98	1.05	1.18	1.28	1.41	1.52	1.64	1.85	-	-	-	-	-	-	-	-	-
617□	6225DA, 6255DB	-	-	0.93	0.96	0.99	1.05	1.16	1.28	1.39	1.49	1.72	1.92	2.17	-	-	-	-	-	-	-
618□	6235DB, 6245DB	-	-	-	0.93	0.96	0.99	1.05	1.15	1.25	1.35	1.56	1.75	1.96	2.17	-	-	-	-	-	-
619□	6255DB, 6265DA, 6275DA	-	-	-	0.93	0.95	0.98	1.00	1.09	1.16	1.25	1.41	1.59	1.75	1.92	2.08	-	-	-	-	-
6205	-	-	-	-	-	0.93	0.95	0.97	1.00	1.04	1.10	1.22	1.33	1.45	1.56	1.68	1.91	-	-	-	-
6215	-	-	-	-	-	0.93	0.95	0.98	1.00	1.03	1.08	1.19	1.29	1.40	1.51	1.61	1.82	-	-	-	-
6225	-	-	-	-	-	0.94	0.96	0.98	1.00	1.02	1.04	1.08	1.14	1.24	1.33	1.42	1.60	-	-	-	-
6235	-	-	-	-	-	0.84	0.86	0.87	0.89	0.93	0.98	1.07	1.16	1.25	1.34	1.44	1.62	-	-	-	-
6245	-	-	-	-	-	0.91	0.92	0.94	0.96	0.98	0.99	1.07	1.15	1.24	1.33	1.42	1.59	-	-	-	-
6255	-	-	-	-	-	-	-	0.92	0.93	0.94	0.96	0.99	1.03	1.09	1.16	1.22	1.34	1.47	1.60	1.72	-
6265	-	-	-	-	-	-	-	0.92	0.93	0.94	0.96	0.99	1.03	1.09	1.16	1.22	1.34	1.47	1.60	1.72	-
6275	-	-	-	-	-	-	-	-	-	0.93	0.94	0.97	0.99	1.04	1.14	1.22	1.39	1.56	1.72	1.92	2.08
Single Reduction	Double Reduction	5	10	15	20	25	30	35	40	45	50	60	70	80	90	100	120	140	160	180	200
Frame Size		Load Location L mm																			

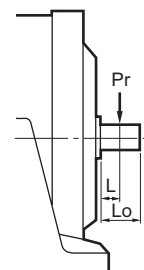

Lf=1 when "L=Lo/2"

Note: □ indicates 0 or 5, expressing combination with reduction ratio.

TECHNICAL DATA
Reducer

Allowable Radial and Axial Load

Table F-14 Radial Load Capacity (High Speed Shaft) Pro (Upper row: N, Lower row: kgf)

(When Cf, Lf, Fs=1)

Frame Size		Reduction Ratio (Double Reduction: Input side)	Input Speed r/min						
Single Reduction	Double Reduction		1750	1450	1165	980	870	720	580
607□SK	-	2.5 - 10	196 20	147 15	147 15	196 20	196 20	196 20	196 20
608□SK	-	2.5 - 10	196 20	147 15	147 15	196 20	196 20	196 20	196 20
609□SK	-	2.5 - 10	294 30	294 30	294 30	294 30	294 30	294 30	294 30
610□SK	-	2.5 - 10	441 45	441 45	491 50	540 55	589 60	589 60	589 60
611□SK	-	2.5 - 10	441 45	343 35	441 45	491 50	491 50	540 55	589 60
606□	606□DA, 607□DA	6 - 17, 25 - 35	196 20	147 15	147 15	196 20	196 20	196 20	196 20
		21, 43	196 8	147 3	147 5	196 5	196 5	196 5	196 5
607□	609□DA, 610□DA, 612□DA 613□DA, 614□DA	6 - 17, 25 - 35, 51, 59	196 20	147 15	147 15	196 20	196 20	196 20	196 20
		21, 43	49.1 5	49.1 5	49.1 5	49.1 5	49.1 5	147 15	196 20
608□	-	6 - 15, 21 - 29, 43 - 59, 87	196 20	147 15	147 15	196 20	196 20	196 20	196 20
		17, 35, 71	49.1 5	49.1 5	49.1 5	49.1 5	49.1 5	147 15	196 20
609□	612□DB, 613□DB, 614□DB 616□DA, 617□DA	6 - 17, 25 - 71, 119	294 30	294 30	294 30	294 30	294 30	294 30	294 30
		21, 87	196 20	196 20	196 20	196 20	245 25	245 25	294 30
610□	613□DC, 614□DC, 616□DB 617□DB, 618VDA	6 - 11, 17 - 119	441 45	441 45	491 50	540 55	589 60	589 60	589 60
		13, 15	441 45	343 35	441 45	491 50	491 50	540 55	589 60
611□	-	6, 8, 21 - 87	441 45	343 35	441 45	491 50	491 50	540 55	589 60
		11 - 17	196 20	196 20	196 20	196 20	245 25	245 25	294 30
612□	616□DC, 617□DC 619□DA, 6205DA	6 - 17	590 60	690 70	740 75	780 80	880 90	880 90	880 90
		21 - 87	540 55	440 45	490 50	540 55	590 60	880 90	880 90
613□	618□DB, 619□DB, 6205DB 6215DA, 6225DA	6 - 17, 21	1370 140	1370 140	1370 140	1520 155	1620 165	1720 175	1860 190
		25 - 87	1280 130	1280 130	1280 130	1370 140	1470 150	1570 160	1770 180
614□	-	6, 8	1370 140	1370 140	1370 140	1520 155	1620 165	1720 175	1860 190
		11 - 21	1230 125	980 100	1080 110	1180 120	1230 125	1320 135	1470 150
		25	1080 110	1130 115	1180 120	1280 130	1320 135	1370 140	1470 150
		29 - 87	540 55	590 60	590 60	690 70	690 70	690 70	1080 110
616□	6215DB, 6235DA, 6245DA	8 - 25, 51, 59	1770 180	1770 180	1960 200	2060 210	2160 220	2160 220	2160 220
		29 - 43, 71, 87	1080 110	1180 120	1280 130	1370 140	1370 140	1570 160	1770 180
617□	6225DA, 6255DB	11 - 87	2060 210	2060 210	2260 230	2260 230	2350 240	2450 250	2650 270
618□	6235DB, 6245DB	11 - 87	2750 280	2550 260	2750 280	2940 300	3040 310	3340 340	3430 350
619□	6255DB, 6265DA, 6275DA	11 - 25	3040 310	3040 310	3240 330	3530 360	3630 370	3920 400	3920 400
		29 - 87	2650 270	2550 260	2840 290	2940 300	3140 320	3340 340	3630 370
6205	-	11 - 87	5400 550	4910 501	5400 550	5890 600	6080 620	6230 635	6180 630
6215	-	11 - 87	5740 585	5100 520	5440 555	6130 625	6330 645	6820 695	7260 740
6225	-	11 - 87	6620 675	5790 590	5980 610	6130 625	6620 675	6970 710	7500 765
6235	-	11 - 87	-	-	10000 1020	9520 970	9170 935	8980 915	8730 890
6245	-	11 - 87	-	-	11100 1130	10100 1030	10100 1030	10600 1080	11200 1140
6255	-	11 - 87	-	-	11800 1200	10800 1100	11300 1150	12300 1250	13100 1340
6265	-	11 - 87	-	-	11800 1200	10800 1100	11300 1150	12300 1250	13100 1340
6275	-	29 - 87	-	-	14700 1500	14700 1500	14700 1500	14700 1500	14700 1500
Single Reduction	Double Reduction	Reduction Ratio (Double Reduction: Input side)	1750	1450	1165	980	870	720	580
Frame Size			Input Speed r/min						

Note: □ indicates 0 or 5, expressing combination with reduction ratio.

TECHNICAL DATA
Reducer

Introduction to Moment of Inertia · GD²

1. Starting Time Moment of Inertia

For successful starting of a driven machine, the starting torque must be adequately larger than the load torque and even after start operation, the motor torque must consistently be greater than the load torque, until reaching full load speed.

The difference between the motor torque and the load torque-during the starting period is referred to as the accelerating torque. If the average accelerating torque is taken as T_a (N·m, kgf·m), the starting time t_s (s) up to the rotating speed n (r/min), is calculated according to the following formula:

$$t_s = \frac{(J_M + J_C + J_L) \cdot n}{9.55 \cdot \bar{T}_a} \quad (\text{S})$$

$$t_s = \frac{(GD_M^2 + GD_C^2 + GD_L^2) \cdot n}{375 \cdot \bar{T}_a} \quad (\text{S})$$

J_M : Motor moment of inertia (Including brake drum)

J_C : CYCLO® reducer moment of Inertia

J_L : Driven machine moment of Inertia (Including coupling and pulley) when converted to the motor shaft.

GD_M^2 : GD² of motor (Including brake drum)

GD_C^2 : GD² of CYCLO® reducer

GD_L^2 : GD² of driven machine (Including coupling and pulley) when converted to the motor shaft.

Average Accelerating Torque \bar{T}_a

Average accelerating torque refers to the average value of the difference between the motor torque and the load torque or the actual torque for accelerating the load, as shown in the right graph. For determining the starting time, the motor torque curve and load torque curve are necessary. However, since it is extremely difficult to determine the average accelerating torque by this method, the average accelerating torque at the actual load time is calculated according to the following formula:

When starting at full voltage, the rough average accelerating torque T_a [N·m kgf·m] may be calculated by the following formula:

$$\bar{T}_a \div 0.8 \left(\frac{T_s + T_m}{2} \right) - \bar{T}_L \quad (\text{N} \cdot \text{m}, \text{kgf} \cdot \text{m})$$

Furthermore, if the average load torque \bar{T}_L (N·m, kgf·m) during the starting period is equivalent to the full load torque, rough \bar{T}_L (N·m, kgf·m) of the motor may be close to the following:

In case of constant torque load $\bar{T}_L \div T_L$ (N·m, kgf·m)

In case of square of reduced torque load $\bar{T}_L \div 0.34 T_L$ (N·m, kgf·m)

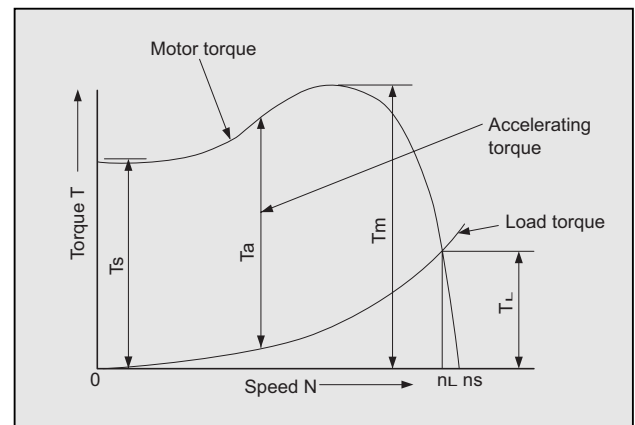

Fig F-9 Torque Curve

T_s : Starting torque

T_m : Maximum torque (Stalling torque)

T_a : Accelerating torque

T_L : Full load torque

n_s : Synchronous rotating speed

n_L : Full load rotating speed

Introduction to Moment of Inertia · GD²

2. Calculation of Moment of Inertia

(1) Moment of Inertia of Rotating Motion

Rotating motion on the center of gravity		Rotating motion off the center of gravity	
	$J = \frac{1}{8} MD^2$ [kg·m ²]		$J = \frac{M}{4} \left(\frac{1}{2} D^2 + 4R^2 \right)$ [kg·m ²]
	$J = \frac{1}{8} M (D^2 + d^2)$ [kg·m ²]		$J = \frac{M}{4} \left(\frac{a^2 + b^2}{3} + 4R^2 \right)$ [kg·m ²]
	$J = \frac{1}{12} M (a^2 + b^2)$ [kg·m ²]		$J = \frac{1}{12} M (4L^2 + C^2)$ [kg·m ²]

(2) Moment of Inertia of Rectilinear Motion (Loaded Shaft Side)

General application		$J = \frac{M}{4} \left(\frac{V}{\pi N_s} \right)^2 = \frac{M}{4} D^2$	[kg·m ²]
Horizontal motion by conveyor		$J = \frac{1}{4} \left(\frac{M_1 + M_2 + M_3 + M_4}{2} \right) \times D^2$	[kg·m ²]
Horizontal motion by lead screw		$J = \frac{M}{4} \left(\frac{V}{\pi N_s} \right)^2 = \frac{M}{4} \left(\frac{P}{\pi} \right)^2$	[kg·m ²]
Vertical motion by hoist		$J = \frac{M_1 D^2}{4} + \frac{1}{8} M_2 D^2$	[kg·m ²]

(3) Calculation of Moment of Inertia at Different Rotating Speeds

	$J_L = \left(\frac{N_{s2}}{N_{s1}} \right)^2 J_R = \left(\frac{1}{Z} \right)^2 J_R$	Z: Total ratio
--	---	----------------

TECHNICAL DATA

Reducer

Introduction to Moment of Inertia · GD²

3. Calculation of GD²

(1) GD² of Rotating Motion

Rotating motion on the center of gravity		Rotating motion off the center of gravity	
	$GD^2 = \frac{1}{2} WD^2$ [kgf·m ²]		$GD^2 = W \left(\frac{1}{2} D^2 + 4R^2 \right)$ [kgf·m ²]
	$GD^2 = \frac{1}{2} W (D^2 + d^2)$ [kgf·m ²]		$GD^2 = W \left(\frac{a^2 + b^2}{3} + 4R^2 \right)$ [kgf·m ²]
	$GD^2 = \frac{1}{3} W (a^2 + b^2)$ [kgf·m ²]		$GD^2 = \frac{1}{3} W (4L^2 + C^2)$ [kgf·m ²]

(2) GD² of Rectilinear Motion (Loaded Shaft Side GD²)

General application		$GD^2 = W \left(\frac{V}{\pi \cdot N} \right)^2 = WD^2$ [kgf·m ²]
Horizontal motion by conveyor		$GD^2 = \left(\frac{W_1 + W_2}{2} + W_3 + W_4 \right) \times D^2$ [kgf·m ²]
Horizontal motion by lead screw		$GD^2 = W \left(\frac{V}{\pi \cdot N} \right)^2 = W \left(\frac{P}{\pi} \right)^2$ [kgf·m ²]
Vertical motion by hoist		$GD^2 = W_1 D^2 + \frac{1}{2} W_2 D^2$ [kgf·m ²]

(3) Calculation of Moment of Inertia at Different Rotating Speeds

	$GD_1^2 = \left(\frac{N_2}{N_1} \right)^2 GD^2 = \left(\frac{1}{Z} \right)^2 GD^2$
	Z: Total ratio

TECHNICAL DATA

Reducer

Introduction to Moment of Inertia · GD²

Moment of Inertia · GD²

Table F-15 Moment of Inertia·GD²on Motor Shaft of CYCLO® Gearmotor (Single Stage Reduction, CYCLO Part Only)

Unit: GD_c² (× 10⁴kgf·m²) J_c (Moment of inertia) (× 10⁴·kg·m²)

Frame Size	Reduction Ratio															
	6		8		11		13		15		17		21		25	
	GD _c ²	J _c	GD _c ²	J _c	GD _c ²	J _c	GD _c ²	J _c	GD _c ²	J _c	GD _c ²	J _c	GD _c ²	J _c	GD _c ²	J _c
6060 6065	0.666	0.167	0.532	0.133	0.449	0.112	0.423	0.106	0.407	0.102	0.396	0.099	0.378	0.095	0.366	0.092
6070 6075	0.682	0.171	0.541	0.135	0.454	0.114	0.426	0.107	0.409	0.102	0.398	0.100	0.379	0.095	0.367	0.092
6080 6085	1.61	0.403	1.32	0.330	1.12	0.280	1.07	0.268	1.02	0.255	0.997	0.249	0.688	0.172	0.665	0.166
6090 6095	3.82	0.955	2.96	0.740	2.37	0.593	2.49	0.623	2.42	0.605	2.12	0.530	1.61	0.403	1.56	0.390
6100 6105	3.07	0.768	2.22	0.555	1.36	0.340	1.40	0.350	1.28	0.320	0.897	0.224	1.03	0.258	0.942	0.236
6110 6115	5.99	1.50	4.44	1.11	3.38	0.845	3.07	0.768	2.88	0.720	2.75	0.688	2.44	0.610	2.38	0.595
6120 6125	12.4	3.10	10.1	2.53	6.24	1.56	6.82	1.71	6.46	1.62	4.82	1.21	5.56	1.39	5.17	1.29
6130 6135	34.3	8.58	23.5	5.88	17.3	4.33	14.7	3.68	13.2	3.30	12.1	3.03	10.0	2.51	9.39	2.35
6140 6145	37.7	9.43	25.6	6.40	18.2	4.55	14.7	3.68	13.3	3.33	11.8	2.95	10.1	2.52	9.41	2.35
6160 6165	98.7	24.7	68.9	17.2	45.4	12.4	41.5	11.0	37.7	9.90	32.2	8.35	29.9	7.65	28.2	71.5
6170 6175	264	66.0	197	49.3	153	37.5	140	35.3	124	31.3	119	30.0	111	28.0	107	27.0
6180 6185	-	-	-	-	231	58.5	209	52.8	186	46.8	177	44.5	167	42.3	156	39.3
6190 6195	-	-	-	-	545	136	503	126	478	120	460	115	428	107	415	104
6205	-	-	-	-	646	162	-	-	565	141	-	-	517	129	-	-
6215	-	-	-	-	990	248	-	-	864	216	-	-	789	197	-	-
6225	-	-	-	-	1220	305	-	-	1030	258	-	-	927	232	-	-
6235	-	-	-	-	1990	498	-	-	1710	428	-	-	1530	383	-	-
6245	-	-	-	-	3610	903	-	-	3170	793	-	-	2890	723	-	-
6255	-	-	-	-	5870	1470	-	-	5120	1280	-	-	4630	1160	-	-
6265	-	-	-	-	8590	2150	-	-	7460	1870	-	-	6800	1700	-	-
6275	-	-	-	-	-	-	-	-	-	-	-	-	-	-	-	-

Frame Size	Reduction Ratio															
	29		35		43		51		59		71		87		119	
	GD _c ²	J _c	GD _c ²	J _c	GD _c ²	J _c	GD _c ²	J _c	GD _c ²	J _c	GD _c ²	J _c	GD _c ²	J _c	GD _c ²	J _c
6060 6065	0.361	0.090	0.356	0.089	0.351	0.088	-	-	-	-	-	-	-	-	-	-
6070 6075	0.362	0.091	0.356	0.089	0.351	0.088	0.348	0.087	0.346	0.087	-	-	-	-	-	-
6080 6085	0.650	0.163	0.633	0.158	0.380	0.095	0.373	0.093	0.370	0.093	0.365	0.091	0.363	0.091	-	-
6090 6095	1.30	0.325	1.01	0.253	0.993	0.248	0.968	0.242	0.723	0.181	0.954	0.239	0.712	0.178	0.944	0.236
6100 6105	0.651	0.163	0.607	0.152	0.573	0.143	0.790	0.198	0.528	0.132	0.767	0.192	0.511	0.128	0.750	0.188
6110 6115	2.32	0.580	2.23	0.558	2.19	0.548	2.13	0.533	2.12	0.530	2.10	0.525	2.09	0.523	-	-
6120 6125	3.63	0.908	3.46	0.865	3.30	0.825	4.58	1.15	3.15	0.788	4.48	1.12	3.04	0.760	-	-
6130 6135	8.63	2.16	8.33	2.08	7.84	1.96	7.71	1.93	7.64	1.91	7.45	1.86	7.40	1.85	-	-
6140 6145	8.63	2.16	8.34	2.09	7.84	1.96	7.65	1.91	7.64	1.91	7.45	1.86	7.40	1.85	-	-
6160 6165	25.2	6.35	24.3	6.10	23.3	5.85	23.0	5.75	23.1	5.78	22.1	5.53	21.8	5.45	-	-
6170 6175	102	25.5	100	25.3	97.7	24.5	96.7	24.2	95.6	23.9	95.2	23.8	94.7	23.7	-	-
6180 6185	149	37.5	147	37.0	144	36.0	140	35.0	139	34.8	138	34.5	137	34.3	-	-
6190 6195	402	101	393	98.3	387	96.8	383	95.8	380	95.0	378	94.5	376	94.0	-	-
6205	482	121	-	-	460	115	-	-	451	113	-	-	446	117	-	-
6215	735	184	-	-	700	175	-	-	686	172	-	-	678	170	-	-
6225	840	210	-	-	788	197	-	-	766	192	-	-	753	188	-	-
6235	1410	353	-	-	1340	335	-	-	1300	325	-	-	1290	323	-	-
6245	2720	680	-	-	2600	650	-	-	2550	638	-	-	2530	633	-	-
6255	4320	1080	-	-	4140	1040	-	-	4060	1020	-	-	4010	1000	-	-
6265	6330	1580	-	-	6030	1510	-	-	5900	1480	-	-	5820	1460	-	-
6275	19600	4900	-	-	18900	4730	-	-	18600	4650	-	-	18400	4600	-	-

Note: 1. Table F-15 does not include GD² of motor.
 Obtain the GD² of the single stage reduction gearmotor by adding the GD² of the motor Tables F-19, 20.
 2. Calculate the GD² of the 2-Stage reduction model from the following formula:

$$GD^2 \text{ of the 2-stage reduction model} = GD^2 \text{ of 1st stage} + \frac{GD^2 \text{ (2nd stage)}}{(\text{Reduction ratio of 1st stage})^2}$$
 Calculate the GD² of the 1st stage (input side) in the same manner as calculating the GD² of single stage reduction model.
 For the GD² of the 2nd stage (output side), the values shown in Table F-15 may be used.

*The values in Table F-15 are subject to change without notice.

Introduction to Moment of Inertia · GD²

Table F-16 Moment of Inertia · GD² on High Speed Shaft of CYCLO® Reducer (Single Stage Reducer)

Unit: GD_c² (× 10⁻⁴kgf·m²) J_c (Moment of inertia) (× 10⁻⁴kg·m²)

Frame Size	Reduction Ratio															
	6		8		11		13		15		17		21		25	
	GD _c ²	J _c	GD _c ²	J _c	GD _c ²	J _c	GD _c ²	J _c	GD _c ²	J _c	GD _c ²	J _c	GD _c ²	J _c	GD _c ²	J _c
6060 6065	0.764	0.191	0.630	0.158	0.547	0.137	0.521	0.130	0.505	0.126	0.494	0.124	0.476	0.119	0.464	0.116
6070 6075	0.780	0.195	0.639	0.160	0.552	0.138	0.524	0.131	0.507	0.127	0.496	0.124	0.477	0.119	0.465	0.116
6080 6085	1.70	0.425	1.41	0.353	1.22	0.305	1.16	0.290	1.11	0.278	1.09	0.273	0.782	0.196	0.759	0.190
6090 6095	4.06	1.015	2.73	0.683	2.60	0.650	2.25	0.563	2.18	0.545	2.36	0.590	1.380	0.345	1.330	0.333
6100 6105	3.32	0.830	1.98	0.495	1.60	0.400	1.15	0.288	1.03	0.259	1.18	0.295	0.783	0.196	0.695	0.174
6110 6115	6.23	1.56	4.68	1.17	3.62	0.905	3.31	0.828	3.12	0.780	2.99	0.748	2.68	0.670	2.62	0.655
6120 6125	13.8	3.45	8.68	2.17	7.64	1.91	5.42	1.36	5.06	1.27	6.22	1.56	4.17	1.04	3.77	0.943
6130 6135	36.8	9.20	26.0	6.50	19.8	4.95	17.2	4.30	15.8	3.95	14.6	3.65	12.6	3.15	18.9	4.73
6140 6145	41.7	10.4	28.9	7.23	21.2	5.30	17.3	4.33	15.8	3.95	14.5	3.63	12.6	3.15	12.0	3.00
6160 6165	146	36.5	116	29.0	92.6	23.2	88.7	22.2	84.9	21.2	79.4	19.9	77.1	19.3	75.4	18.9
6170 6175	315	78.8	248	62.0	204	51.0	191	47.8	175	43.8	170	42.5	161	40.3	158	39.5
6180 6185	-	-	-	-	292	73.0	271	67.8	247	61.8	239	59.8	228	57.0	217	54.3
6190 6195	-	-	-	-	678	169	636	159	611	152	594	148	561	140	548	137
6205	-	-	-	-	946	237	-	-	864	216	-	-	817	204	-	-
6215	-	-	-	-	1490	373	-	-	1360	340	-	-	1290	323	-	-
6225	-	-	-	-	1930	483	-	-	1750	438	-	-	1640	410	-	-
6235	-	-	-	-	3240	810	-	-	2960	740	-	-	2780	695	-	-
6245	-	-	-	-	4940	1240	-	-	4500	1130	-	-	4220	1060	-	-
6255	-	-	-	-	8910	2230	-	-	8160	2040	-	-	7670	1920	-	-
6265	-	-	-	-	11700	2930	-	-	10600	2650	-	-	9960	2490	-	-
6275	-	-	-	-	-	-	-	-	-	-	-	-	-	-	-	-

Frame Size	Reduction Ratio																GD ² of fan Moment of Inertia	
	29		35		43		51		59		71		87		119		GD _c ²	J _c
	GD _c ²	J _c	GD _c ²	J _c	GD _c ²	J _c	GD _c ²	J _c	GD _c ²	J _c	GD _c ²	J _c	GD _c ²	J _c	GD _c ²	J _c		
6060 6065	0.460	0.115	0.454	0.114	0.449	0.112	-	-	-	-	-	-	-	-	-	-	-	-
6070 6075	0.460	0.115	0.454	0.114	0.450	0.113	0.446	0.112	0.445	0.111	-	-	-	-	-	-	-	-
6080 6085	0.744	0.186	0.727	0.182	0.474	0.119	0.467	0.117	0.463	0.116	0.459	0.115	0.456	0.114	-	-	-	-
6090 6095	1.54	0.385	1.25	0.313	1.23	0.308	0.731	0.183	0.960	0.240	0.717	0.179	0.949	0.237	0.707	0.177	-	-
6100 6105	0.899	0.225	0.854	0.214	0.820	0.205	0.543	0.136	0.776	0.194	0.520	0.130	0.758	0.190	0.503	0.126	-	-
6110 6115	2.56	0.64	2.47	0.618	2.43	0.608	2.37	0.593	2.36	0.590	2.34	0.585	2.33	0.583	-	-	-	-
6120 6125	5.03	1.26	4.86	1.22	4.70	1.18	3.19	0.798	4.55	1.14	3.08	0.770	4.44	1.11	-	-	-	-
6130 6135	11.2	2.80	10.9	2.73	10.3	2.58	10.2	2.55	10.2	2.55	9.97	2.49	9.93	2.48	-	-	-	-
6140 6145	11.2	2.80	10.9	2.73	10.3	2.58	10.2	2.55	10.2	2.55	9.99	2.50	9.93	2.48	-	-	-	-
6160 6165	72.4	18.1	71.5	17.9	70.5	17.6	70.2	17.6	70.3	17.6	69.3	17.3	69.0	17.3	-	-	35.4	8.85
6170 6175	153	38.3	151	37.8	148	37.0	147	36.8	146	36.5	146	36.5	145	36.3	-	-	33.3	8.33
6180 6185	211	52.8	209	52.3	206	51.5	202	50.5	200	50.0	199	49.8	198	49.5	-	-	32.7	8.18
6190 6195	535	133	527	131	520	130	516	129	513	128	511	127	509	127	-	-	83.6	20.9
6205	782	196	-	-	760	190	-	-	750	188	-	-	745	186	-	-	248	62.0
6215	1240	310	-	-	1200	300	-	-	1190	298	-	-	1180	295	-	-	419	105
6225	1550	388	-	-	1500	375	-	-	1480	370	-	-	1470	368	-	-	599	150
6235	2660	665	-	-	2580	645	-	-	2550	638	-	-	2530	633	-	-	1040	260
6245	4040	1010	-	-	3930	983	-	-	3880	970	-	-	3850	963	-	-	1040	260
6255	7360	1840	-	-	7180	1800	-	-	7100	1780	-	-	7060	1770	-	-	2370	593
6265	9480	2370	-	-	9180	2300	-	-	9050	2260	-	-	8980	2250	-	-	2370	593
6275	-	-	-	-	29900	7480	-	-	29600	7400	-	-	29400	7350	-	-	9540	2390

Note: 1. The value of the fan has been to the GD² of the Frame sizes of 6160~6275.
 2. The GD² of the 2-stage reduction model is calculated by the following formula:

$$GD^2 \text{ of the 2-stage reduction model} = GD^2 \text{ of 1st stage} + \frac{GD^2 \text{ (2nd stage)}}{(\text{Reduction ratio of 1st stage})^2}$$

 Use value in Table F-16 for GD² of 1st stage.
 For the GD² of the 2nd stage, deduct the GD² of the fan from the value in Table F-16.

*The values in Table F-16 are subject to change without notice.

TECHNICAL DATA
Reducer

Moment of Inertia · GD²

Table F-17 (6000SK Series, Gearmotor)

Unit: GD_c² (× 10⁻⁴kgf·m²) J_c (Moment of inertia) (× 10⁻⁴kgf·m²)

Frame Size	Nominal Reduction Ratio													
	2.5		3		4		5		6		8		10	
	GD _c ²	J _c	GD _c ²	J _c	GD _c ²	J _c	GD _c ²	J _c	GD _c ²	J _c	GD _c ²	J _c	GD _c ²	J _c
6070SK 6075SK	1.62	0.406	1.27	0.317	0.775	0.194	1.38	0.346	1.09	0.272	0.679	0.170	0.660	0.165
6080SK 6085SK	4.23	1.06	3.91	0.977	0.802	0.201	0.527	0.132	1.81	0.452	1.43	0.359	1.38	0.346
6090SK 6095SK	10.0	2.51	7.81	1.95	6.80	1.70	6.36	1.59	4.44	1.11	2.51	0.628	2.40	0.601
6100SK 6105SK	10.0	2.51	7.81	1.95	6.80	1.70	6.36	1.59	4.44	1.11	2.51	0.628	2.40	0.601
6110SK 6115SK	22.5	5.63	20.5	5.13	18.6	4.64	14.3	3.58	9.97	2.49	6.84	1.71	6.42	1.61

Note: 1. Table F-17 does not include GD² of motor.

Obtain the GD² of the single stage reduction gearmotor by adding the GD² of the motor Tables F-19, 20.

*Values in the table are subject to change without notice.

Table F-18 (6000SK Series, Reducer)

Unit: GD_c² (× 10⁻⁴kgf·m²) J_c (Moment of inertia) (× 10⁻⁴kgf·m²)

Frame Size	Nominal Reduction Ratio													
	2.5		3		4		5		6		8		10	
	GD _c ²	J _c	GD _c ²	J _c	GD _c ²	J _c	GD _c ²	J _c	GD _c ²	J _c	GD _c ²	J _c	GD _c ²	J _c
6070SK 6075SK	1.71	0.428	1.36	0.340	0.865	0.216	1.47	0.368	1.18	0.295	0.769	0.192	0.750	0.187
6080SK 6085SK	4.47	1.12	4.15	1.04	1.04	0.261	0.767	0.192	2.05	0.512	1.67	0.419	1.62	0.406
6090SK 6095SK	10.3	2.57	8.06	2.01	7.05	1.76	6.61	1.65	4.69	1.17	2.76	0.691	2.65	0.663
6100SK 6105SK	10.3	2.57	8.05	2.01	7.04	1.76	6.60	1.65	4.68	1.17	2.75	0.688	2.64	0.661
6110SK 6115SK	23.9	5.98	21.9	5.48	20.0	4.99	15.7	3.93	11.4	2.84	8.24	2.06	7.82	1.96

*Values in the table are subject to change without notice.

TECHNICAL
DATA

Reducer

Moment of Inertia · GD²

Table F-19 Moment of Inertia · GD² of Three Phase Motor

[4P Motor]

Unit: GD_M² (kgf·m²) J_M (Moment of inertia) (kg·m²)

kW × P	0.1kW × 4P		0.2kW × 4P		0.25kW × 4P		0.4kW × 4P		0.55kW × 4P		0.75kW × 4P	
	GD _M ²	J _M	GD _M ²	J _M	GD _M ²	J _M	GD _M ²	J _M	GD _M ²	J _M	GD _M ²	J _M
Standard	0.0013	0.000325	0.0020	0.000500	0.0020	0.000500	0.0026	0.000650	0.0041	0.00101	0.0048	0.00120
With Brake	0.0014	0.000350	0.0022	0.000550	0.0022	0.000550	0.0027	0.000675	0.0045	0.00111	0.0052	0.00130

kW × P	1.1kW × 4P		1.5kW × 4P		2.2kW × 4P		3.0kW × 4P		3.7kW × 4P		5.5kW × 4P	
	GD _M ²	J _M	GD _M ²	J _M	GD _M ²	J _M	GD _M ²	J _M	GD _M ²	J _M	GD _M ²	J _M
Standard	0.0074	0.00185	0.0085	0.00213	0.0133	0.00333	0.0281	0.00700	0.0339	0.00848	0.0457	0.0114
With Brake	0.0083	0.00208	0.0094	0.00235	0.0149	0.00373	0.0325	0.00810	0.0383	0.00958	0.0501	0.0125

kW × P	7.5kW × 4P		11kW × 4P		15kW × 4P		18.5kW × 4P		22kW × 4P		30W × 4P	
	GD _M ²	J _M	GD _M ²	J _M	GD _M ²	J _M	GD _M ²	J _M	GD _M ²	J _M	GD _M ²	J _M
Standard	0.107	0.0268	0.150	0.0375	0.359	0.0898	0.900	0.225	0.900	0.225	1.00	0.250
With Brake	0.121	0.0303	0.164	0.0410	0.428	0.107	0.972	0.243	0.972	0.243	1.05	0.262

kW × P	37kW × 4P		45kW × 4P		55kW × 4P	
	GD _M ²	J _M	GD _M ²	J _M	GD _M ²	J _M
Standard	1.23	0.308	1.37	0.343	2.70	0.675
With Brake	1.28	0.321	-	-	-	-

[6P Motor]

kW × P	0.1kW × 6P		0.2kW × 6P		0.25kW × 6P		0.4kW × 6P		0.55kW × 6P		0.75kW × 6P	
	GD _M ²	J _M	GD _M ²	J _M	GD _M ²	J _M	GD _M ²	J _M	GD _M ²	J _M	GD _M ²	J _M
Standard	0.0023	0.000575	0.0031	0.000775	0.0031	0.000775	0.0067	0.00168	0.0077	0.00193	0.0120	0.00300
With Brake	0.0025	0.000625	0.0032	0.000800	0.0032	0.000800	0.0071	0.00178	0.0081	0.00203	0.0129	0.00323

kW × P	1.1kW × 6P		1.5kW × 6P		2.2kW × 6P		3.0kW × 6P		3.7kW × 6P		5.5kW × 6P	
	GD _M ²	J _M	GD _M ²	J _M	GD _M ²	J _M	GD _M ²	J _M	GD _M ²	J _M	GD _M ²	J _M
Standard	0.0145	0.00363	0.0212	0.00530	0.0527	0.0132	0.0657	0.0164	0.0740	0.0185	0.140	0.0350
With Brake	0.0154	0.00385	0.0228	0.00570	0.0571	0.0143	0.0701	0.0175	0.0784	0.0196	0.154	0.0385

kW × P	7.5kW × 6P		11kW × 6P		15kW × 6P		18.5kW × 6P		22kW × 6P		30W × 6P	
	GD _M ²	J _M	GD _M ²	J _M	GD _M ²	J _M	GD _M ²	J _M	GD _M ²	J _M	GD _M ²	J _M
Standard	0.286	0.0715	0.359	0.0898	1.27	0.318	1.45	0.363	1.45	0.363	1.90	0.475
With Brake	0.355	0.0888	0.428	0.1070	-	-	-	-	-	-	-	-

kW × P	37kW × 6P		45kW × 6P		55kW × 6P	
	GD _M ²	J _M	GD _M ²	J _M	GD _M ²	J _M
Standard	2.40	0.600	4.00	1.00	4.70	1.18
With Brake	-	-	-	-	-	-

TECHNICAL DATA

Reducer

Table F-20 Moment of Inertia · GD² of Motor for Inverter

Unit: GD_M² (kgf·m²) J_M (Moment of inertia) (kg·m²)

kW × P	0.1kW × 4P		0.2kW × 4P		0.4kW × 4P		0.75kW × 4P		1.5kW × 4P		2.2kW × 4P	
	GD _M ²	J _M	GD _M ²	J _M	GD _M ²	J _M	GD _M ²	J _M	GD _M ²	J _M	GD _M ²	J _M
Standard	0.0020	0.000500	0.0026	0.000650	0.0048	0.00120	0.0085	0.00213	0.0133	0.00333	0.0339	0.00848
With Brake	0.0022	0.000550	0.0027	0.000675	0.0052	0.00130	0.0094	0.00235	0.0149	0.00373	0.0383	0.00958

kW × P	3.7kW × 4P		5.5kW × 4P		7.5kW × 4P		11kW × 4P		15kW × 4P		18.5W × 4P	
	GD _M ²	J _M	GD _M ²	J _M	GD _M ²	J _M	GD _M ²	J _M	GD _M ²	J _M	GD _M ²	J _M
Standard	0.0457	0.0114	0.107	0.0268	0.150	0.0375	0.359	0.0898	0.900	0.225	1.00	0.250
With Brake	0.0501	0.0125	0.121	0.0303	0.164	0.0410	0.428	0.1070	0.972	0.243	1.05	0.262

kW × P	22kW × 4P		30kW × 4P		37kW × 4P	
	GD _M ²	J _M	GD _M ²	J _M	GD _M ²	J _M
Standard	1.00	0.250	1.23	0.308	1.37	0.343
With Brake	1.05	0.262	1.28	0.321	-	-

Moment of Inertia · GD²

[Example 1] CNHM2-6115-29

- (1) $J_M = 0.00213\text{kg}\cdot\text{m}^2$
(Standard 1.5kW × 4-Pole motor in Table F-19)
- (2) Frame size 6115 of CYCLO® reducer.
 J_c : Reduction ratio of 29 = $0.580 \times 10^{-4}\text{kg}\cdot\text{m}^2$ (From the Table F-15)
- (3) ΣJ_c of CNHM2-6115-29
 $\Sigma J = \text{Motor } J_M + \text{CYCLO® reducer } J_c$
 $= 0.00213 + 0.000058$
 $= 0.002188\text{kg}\cdot\text{m}^2$

[Example 2] CVVM20-6215DA-165 (15 × 11)

- (1) $J_M = 0.0898\text{kg}\cdot\text{m}^2$ (Standard 15kW × 4-Pole motor in Table F-19)
- (2) Combination of CYCLO® reducer, Frame size 6215 with ratio 15 + Frame size 6135 with ratio 11 (Refer to Page A-4)
- (3) 1st stage of 6135 Ratio 11, $J_c = 4.33 \times 10^{-4}\text{kg}\cdot\text{m}^2$
- (4) 2nd stage of 6215 Ratio 15, $J_c = 216 \times 10^{-4}\text{kg}\cdot\text{m}^2$
(Both (3) & (4) from Table F-15)
- (5) CYCLO® reducer $J_c = 4.33 \times 10^{-4} + \frac{216 \times 10^{-4}}{11^2} = 0.0006\text{kg}\cdot\text{m}^2$
- (6) ΣJ of CVVM20-6215DA-165
 $\Sigma J = \text{Motor } J_M + \text{CYCLO® reducer } J_c$
 $= 0.0898 + 0.0006$
 $= 0.0904\text{kg}\cdot\text{m}^2$

Construction Drawing

1. Construction of 6000 Series

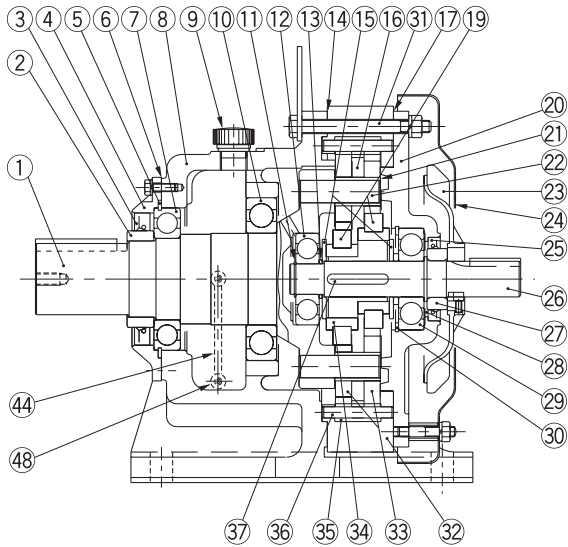

Fig F-10 Type CHH (Horizontal, Reducer) Single reduction
(Example: Frame size 6175)

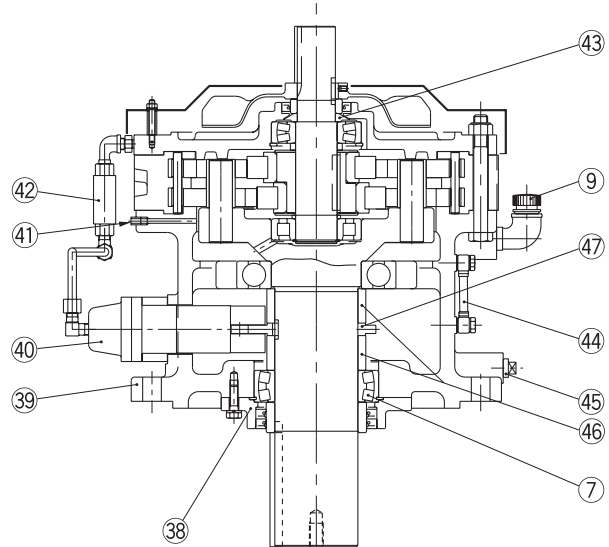

Fig F-11 Type CVV (Vertical, Reducer) Single reduction
(Example: Frame size 6225)

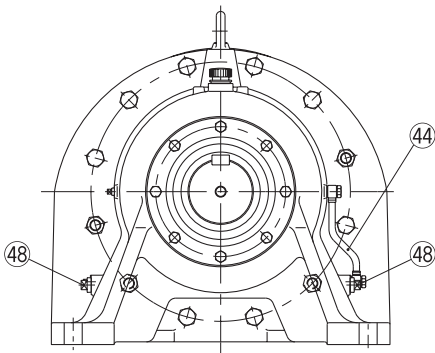

Fig F-12 Type CHHM (Horizontal, Gearmotor) Single reduction
(Example: Frame size 6225)

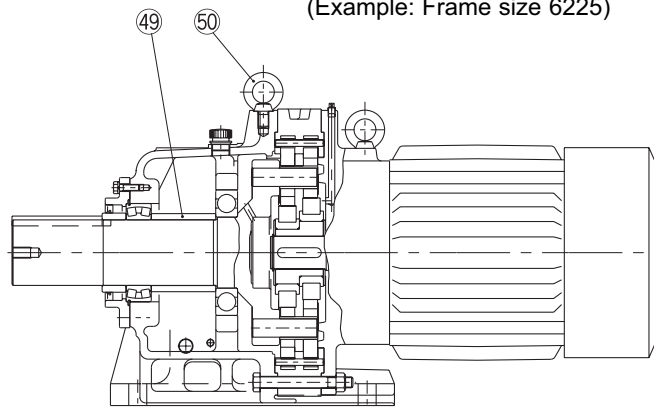

Fig F-13 Type CNHM (Horizontal, Gearmotor) Single reduction
(Example: Frame size 6095)

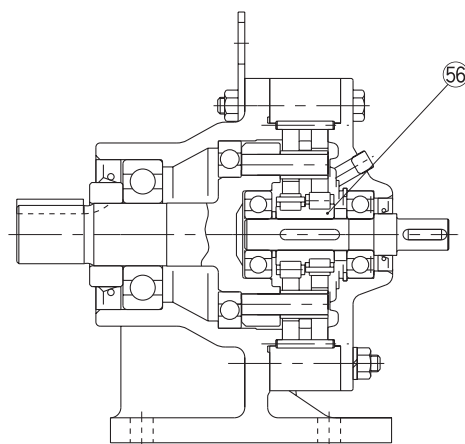

Fig F-14 Type CNH (Horizontal, Reducer) Single reduction
(Example: Frame size 6105)

TECHNICAL
DATA

Reducer

Construction Drawing

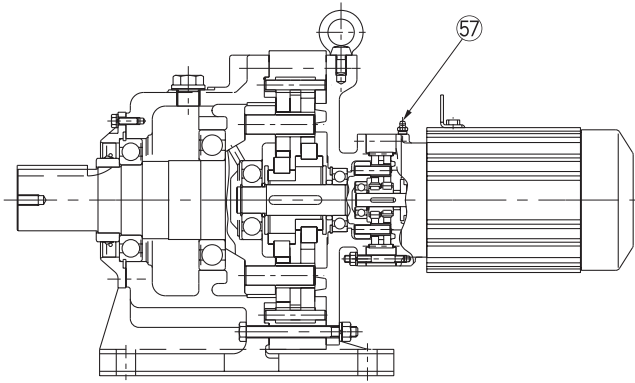

Fig F-15 Type CHHM (Horizontal, Gearmotor)
Double reduction
(Example: Frame size grease lubricated 6185DB)

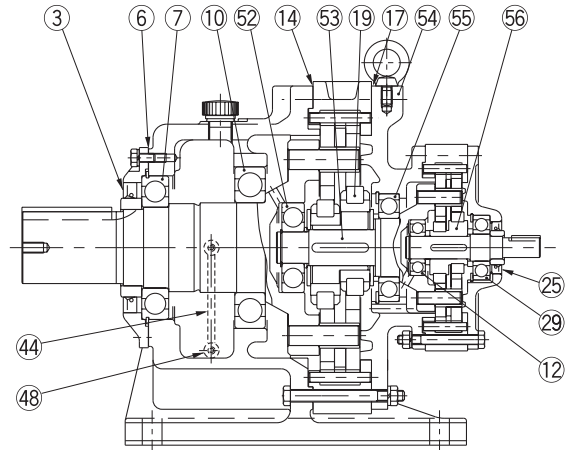

Fig F-16 Type CHH (Horizontal, Reducer)
Double reduction
(Example: Frame size 6185DB)

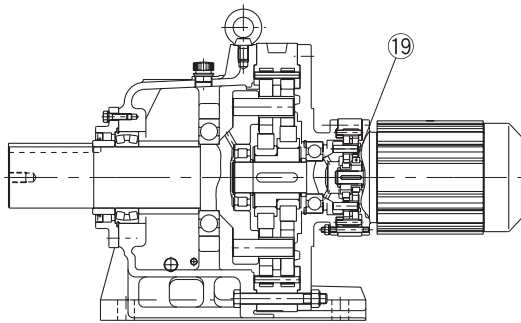

Fig F-17 Type CHHM (Horizontal, Gearmotor)
Double reduction
(Example: Frame size 6225DB)

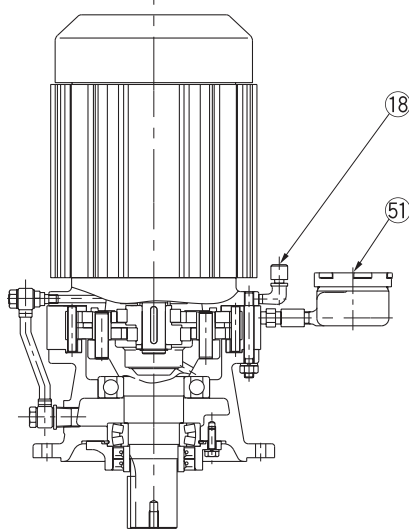

Fig F-18 Type CVVM
(Vertical, Gearmotor)
Single reduction
(Example: Frame size 6145)

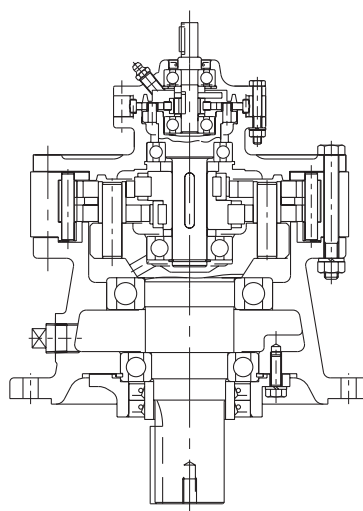

Fig F-19 Type CVV
(Vertical, Reducer)
Double reduction
(Example: Frame size 6135DA)

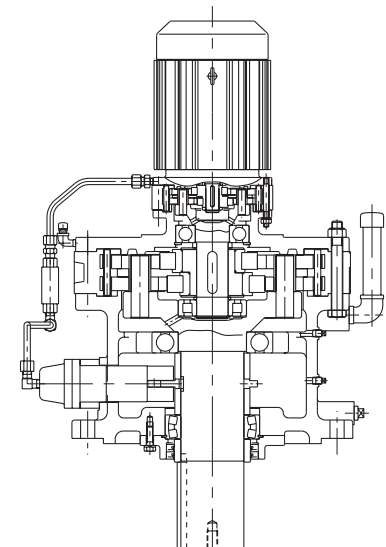

Fig F-20 Type CVVM
(Vertical, Gearmotor)
Double reduction
(Example: Frame size 6225DA)

TECHNICAL DATA
Reducer

Principal parts

No.	Part Name	No.	Part Name	No.	Part Name	No.	Part Name	No.	Part Name
1	Slow speed shaft	13	Spacer	25	Oil seal	37	Key	49	Spacer
2	Collar (Slow speed shaft)	14	Gasket B	26	High speed shaft	38	Gland	50	Eye bolt
3	Oil seal	15	End plate	27	Collar (High Speed Shaft)	39	Flanged casing	51	Oil filler
4	Slow speed end cap	16	Spacer ring	28	Spacer	40	Plunger pump	52	Intermediate shaft, bearing A
5	Retaining ring	17	Gasket C	29	High speed shaft, bearing B	41	Air vent plug	53	Intermediate shaft
6	Gasket A	18	Air vent plug	30	Retaining ring	42	Oil signal	54	Intermediate cover
7	Slow speed shaft, bearing A	19	Bearing for eccentric (High speed shaft section)	31	Bolt for ring gear housing	43	Oil slinger	55	Intermediate shaft, bearing B
8	Horizontal casing	20	High speed end shield	32	Ring gear housing	44	Oil level gauge	56	Eccentric bearing (Double)
9	Oil filler plug	21	Slow speed shaft roller	33	Cycloid disc	45	Plug (Oil drain)	57	Grease nipple
10	Slow speed shaft, bearing B	22	Slow speed shaft pin	34	Eccentric	46	Spacer		
11	Retaining ring	23	Cooling fan	35	Ring gear roller	47	Cam		
12	High speed shaft, bearing A	24	Fan cover	36	Ring gear pin	48	Plug (Oil drain)		

Construction Drawing

2. Construction of 6000SK Series

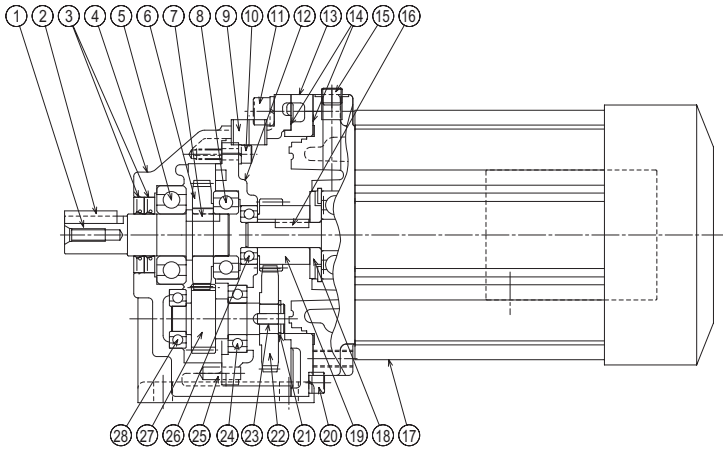

Fig F-21 Type CHHM
(6000SK Series Horizontal, Gearmotor)
(Example: Frame size 6075SK)

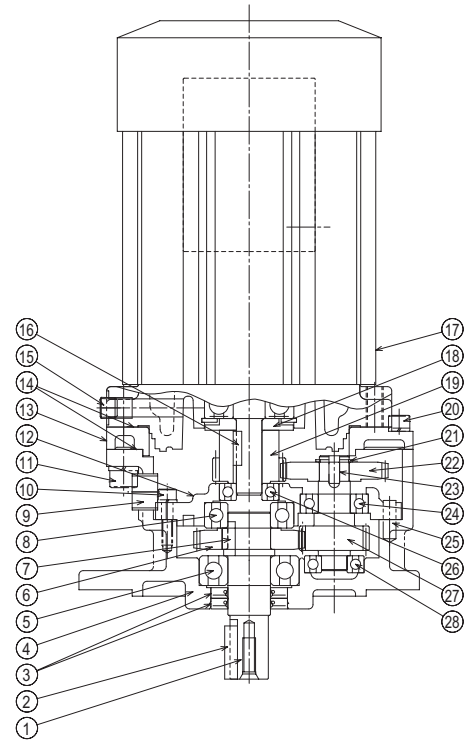

Fig F-22 Type CVVM
(6000SK Series Vertical, Gearmotor)
(Example: Frame size 6075SK)

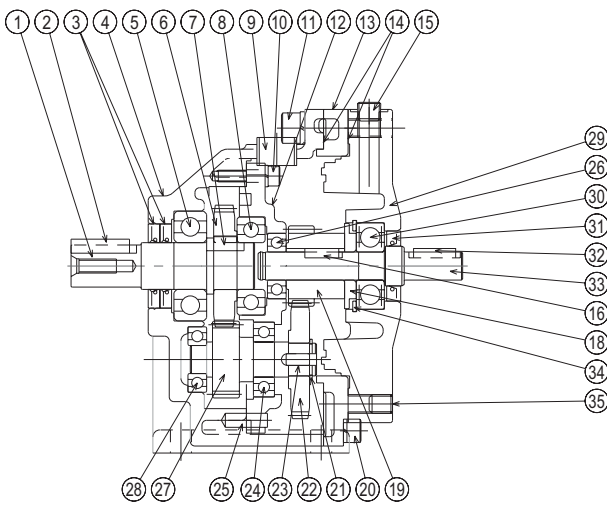

Fig F-23 Type CHH
(6000SK Series Horizontal, Reducer)
(Example: Frame size 6075SK)

TECHNICAL
DATA

Reducer

Principal parts

No.	Part Name	No.	Part Name	No.	Part Name	No.	Part Name
1	Slow speed shaft (Output shaft)	11	Hexagon socket head cap screw	21	Snap ring	31	Oil seal
2	Key	12	Bearing plate	22	First gear	32	Key
3	Oil seal	13	Adapter plate	23	Key	33	High speed shaft
4	Horizontal casing	14	Liquid gasket	24	Bearing (B) for mid speed shaft	34	Snap ring
5	Bearing (A) for slow speed shaft	15	Plug	25	Pin	35	Hexagon socket head cap screw
6	Second gear	16	Key	26	Bearing (A) for high speed shaft		
7	Key	17	Motor	27	Second pinion (middle speed shaft)		
8	Bearing (B) for slow speed shaft	18	Oil slinger	28	Bearing (A) for middle speed shaft		
9	Plug	19	First pinion	29	High speed end shield		
10	Hexagon socket head cap screw	20	Hexagon socket head cap screw	30	Bearing (B) for high speed shaft		

Detailed Dimension of Slow Speed Shaft

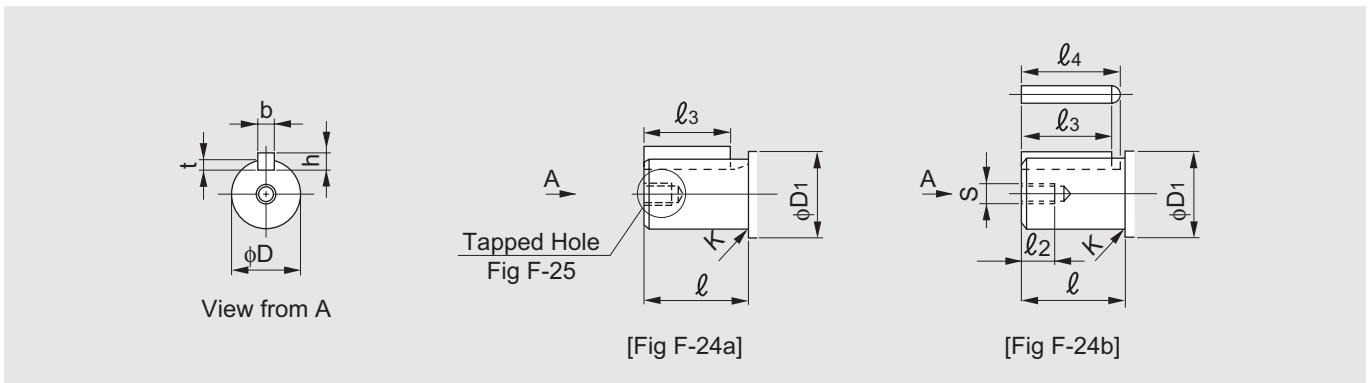

- Dimension of slow speed shaft end; Dimension tolerance in accordance with JIS B 0401-1976 "h6."
- Dimension of shaft end key; Parallel key in accordance with JIS B 1301-1996.

Table F-23 Dimension of Slow Speed Shaft

6000SK Series	Frame Size		Fig	D (h6)	Slow Speed Shaft											
	Single	Double			Tolerance	D1	l	K (Roundness)	t	Tolerance	b(key) (h9)	Tolerance	h(key)	Tolerance	l3 (key)	l4
-	6060	6060DA	F-24b	14		30	25	-	3		5		5		20	22.5
-	6065	6065DA														
-	6070	6070DA			0	30		-								
-	6075	6075DA	F-24b	18	-0.011	30			3.5		6	0	6	0	25	-
6070SK	-	-				20		0.6		+0.1					28	
6075SK	-	-								0						
-	6080	-				45		-								
-	6085	-	F-24b	22		35			3.5		6		6		30	33
6080SK	-	-				25		0.6								33
6085SK	-	-														
-	6090	6090DA	F-24a			45		-							32	-
-	6095	6095DA														
6090SK	-	-	F-24b	28	0	30		0.5	4		8		7		27	32
6095SK	-	-			-0.013											
-	6100	6100DA	F-24a			50		-							32	-
-	6105	6105DA														
-	610H	-														
6100SK	-	-	F-24b	28		30		0.5	4	+0.2	8	0	7	0	27	32
6105SK	-	-								0						
-	6110	-	F-24b			55		-							37	42
-	6115	-														
6110SK	-	-	F-24b	32		45			5		10		8		37	40
6115SK	-	-			0	35		1								
-	6120	6120DA 6120DB			-0.016											
-	6125	6125DA 6125DB	F-24a	38		65	55	-	5		10		8		50	-
-	612H	-														

Table F-24 Dimension of Tapped Hole

6000SK Series	Frame Size		Tap	Depth	Center hole		
	Single	Double			phi D1	phi D2	B
-	6060	6060DA	M5	16	7	5.2	2.6
-	6065	6065DA	M5	16	7	5.2	2.6
6070SK	6070	6070DA	M6	16	9	6.2	3.4
6075SK	6075	6075DA	M6	16	9	6.2	3.4
6080SK	6080	-	M6	16	9	6.2	3.4
6085SK	6085	-	M6	16	9	6.2	3.4
6090SK	6090	6090DA	M8	20	11	8.2	3.6
6095SK	6095	6095DA	M8	20	11	8.2	3.6
6100SK	6100	6100DA	M8	20	11	8.2	3.6
6105SK	6105	6105DA	M8	20	11	8.2	3.6
-	610H	-	M8	20	11	8.2	3.6
6110SK	6110	-	M8	20	11	8.2	3.6
6115SK	6115	-	M8	20	11	8.2	3.6
-	6120	6120DA 6120DB	M8	20	11	8.2	3.6
-	6125	6125DA 6125DB	M8	20	11	8.2	3.6
-	612H	-	M8	20	11	8.2	3.6

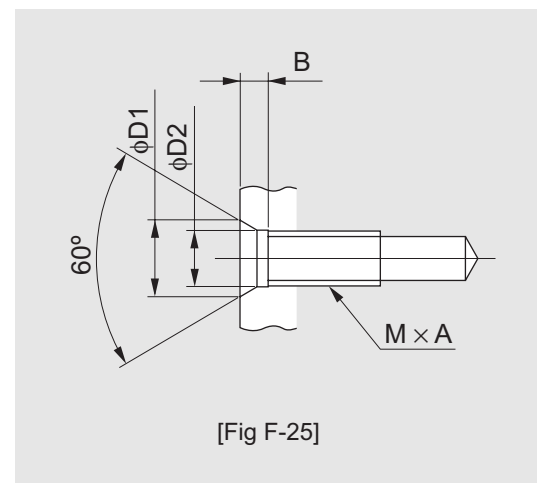

Detailed Dimension of Slow Speed Shaft

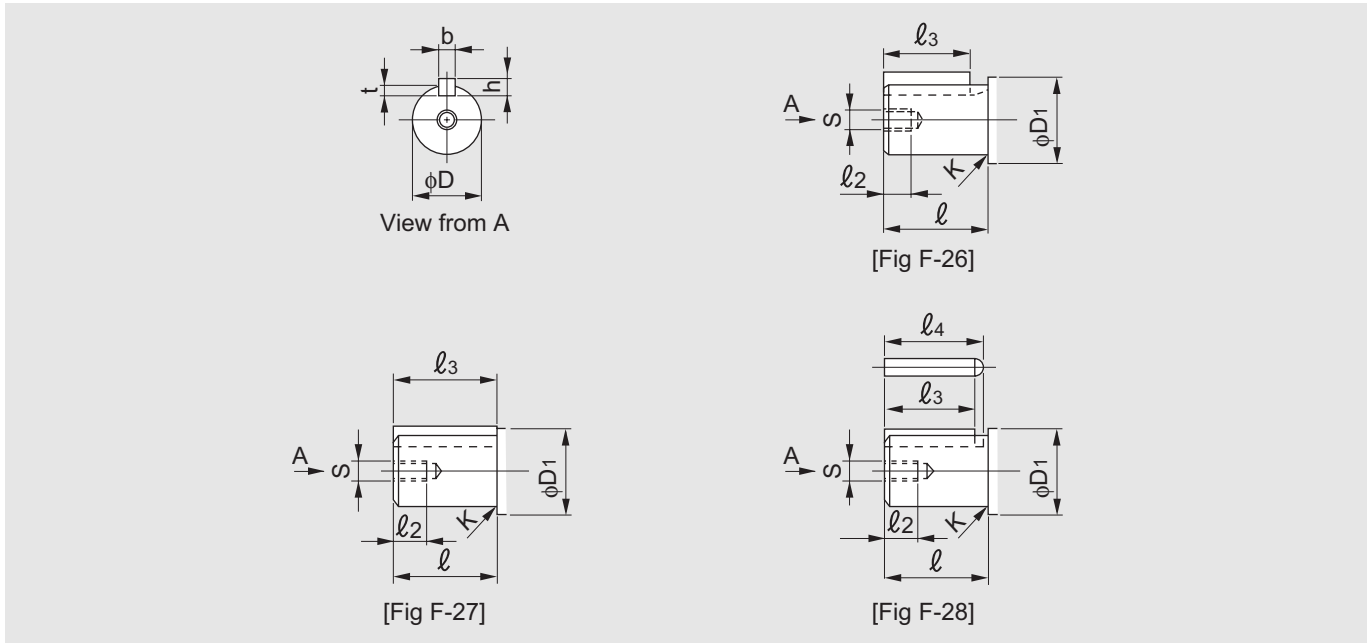

Table F-25 Dimension of Slow Speed Shaft

Frame Size			Slow Speed Shaft																
Single	Double		Fig	D (h6)	Tolerance	D ₁	ℓ	K (Roundness)	s	ℓ ₂	t	Tolerance	b (key) (h9)	Tolerance	h (key)	Tolerance	ℓ ₃ (key)	ℓ ₄	
6130	6130DA	6130DB	6130DC	F-26	50	0 -0.016	65	70 (61)	-	M10	18	5.5	+0.2 0	14	0 -0.043	9	0	56	-
6135	6135DA	6135DB	6135DC	F-26	50		65	90 (81)	-	M10	18	5.5		14		9	-0.090	80	-
6140	6140DA	6140DB	6140DC	F-26	60	0 -0.019	85	90 (80)	-	M10	18	7	+0.2 0	18	0 -0.052	11	0	80	-
6145	6145DA	6145DB	6145DC	F-26			70	95	90 (84)	-	M12	24		7.5		20	12	-0.110	80
614H	-	-	-	F-26	80	0 -0.022	110	110 (100)	-	M12	24	9	+0.3 0	22	0 -0.063	14	0	100	-
6160	6160DA	6160DB	6160DC	F-26	95		120	135 (125)	-	M20	34	9		25		14	-0.130	125	137.5
6165	6165DA	6165DB	6165DC	F-26	100	0 -0.025	120	165	-	M20	34	10	+0.3 0	28	0 -0.063	16	0	165	-
616H	-	-	-	F-26			110	130	165	-	M20	34		10		28	16	-0.130	165
6170	6170DA	6170DB	6170DC	F-26	120	0 -0.025	145	165	-	M20	34	11	+0.3 0	32	0 -0.063	18	0	165	-
6175	6175DA	6175DB	6175DC	F-26			130	160	200	-	M24	41		11		32	18	-0.130	200
6180	6180DA	6180DB	-	F-26	140	0 -0.025	170	200	-	M24	41	12	+0.3 0	36	0 -0.063	20	0	200	-
6185	6185DA	6185DB	-	F-26			190	240	-	M30	49	13		40		22	0	-0.130	240
6190	6190DA	6190DB	-	F-28	160	0 -0.025	200	300	-	M30	49	13	+0.3 0	40	0 -0.063	22	0	300	-
6195	6195DA	6195DB	-	F-28			230	330 (320)	-	M30	52	15		45		25	-0.130	330 (320)	-
6205	6205DA	6205DB	-	F-27	170	0 -0.025	200	300	-	M30	49	13	+0.3 0	40	0 -0.063	22	0	300	-
6215	6215DA	6215DB	-	F-27			230	330 (320)	-	M30	52	15		45		25	-0.130	330 (320)	-
6225	6225DA	6225DB	-	F-27	180	0 -0.025	230	330 (320)	-	M30	52	15	+0.3 0	45	0 -0.063	25	0	330 (320)	-
6235	6235DA	6235DB	-	F-27			230	330 (320)	-	M30	52	15		45		25	-0.130	330 (320)	-
6245	6245DA	6245DB	-	F-27	180	0 -0.025	230	330 (320)	-	M30	52	15	+0.3 0	45	0 -0.063	25	0	330 (320)	-
6255	6255DA	6255DB	-	F-27			230	330 (320)	-	M30	52	15		45		25	-0.130	330 (320)	-
6265	6265DA	-	-	F-27	180	0 -0.025	230	330 (320)	-	M30	52	15	+0.3 0	45	0 -0.063	25	0	330 (320)	-
6275	6275DA	-	-	F-27			230	330 (320)	-	M30	52	15		45		25	-0.130	330 (320)	-

Note: Dimensions in parentheses for ℓ and ℓ₃ are for models with vertical output shaft.

TECHNICAL DATA
Reducer

Detailed Dimension of High Speed Shaft

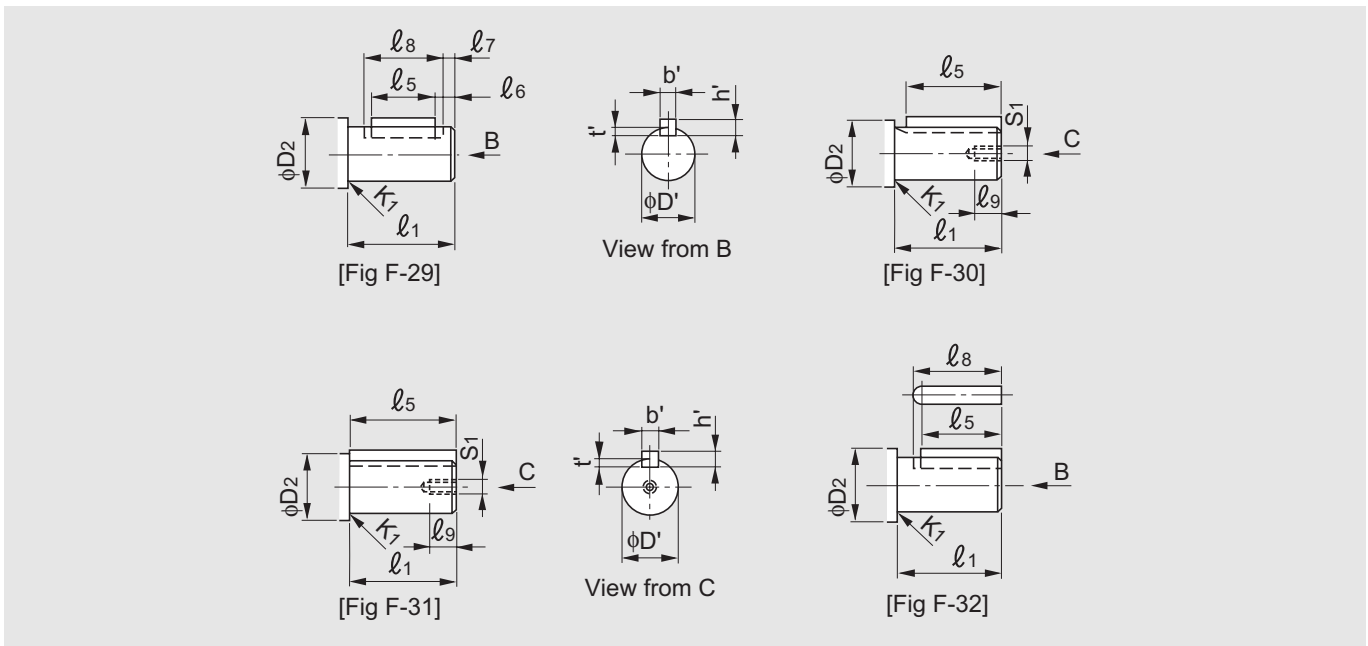

- Dimension of high speed shaft end; Dimension tolerance in accordance with JIS B 0401-1976 "h6".
- Dimension of shaft end key; Parallel key in accordance with JIS B 1301-1996.
- *S1 & 9 Dimension Tap Hole is only for vertical (Type CVV, CVF) Single stage only

Table F-26 Dimension of High Speed Shaft

Frame Size				High Speed Shaft															
6000SK Series	6000 Series			Fig	D' (h6)	D ₂	ℓ ₁	K _r (Roundness)	t' (Tolerance)	b' (key) (h9)		h' (key) (Tolerance)		ℓ ₅ (key)	ℓ ₆	ℓ ₇	ℓ ₈	*S ₁	*ℓ ₉
	Single	Double								Tolerance	Tolerance	Tolerance	Tolerance						
-	6060	6060DA 6070DA		F-29	12	17	25	0.5	2.5	4		4		18				-	-
-	6065	6065DA 6075DA		F-29	12	17	25	0.5	2.5	4		4		18	3		22	-	-
-	6070	6090DA	6100DA 6120DA 6130DA 6140DA	F-29	12	17	25	0.5	2.5	4		4		18				-	-
-	6075	6095DA	6105DA 6125DA 6135DA 6145DA	F-29	12	17	25	0.5	2.5	4		4		18				-	-
6070SK	6080	-		F-29	12	17	25	0.5	2.5	4		4		18				-	-
6075SK	6085	-		F-29	12	17	25	0.5	2.5	4		4		18				-	-
6080SK	6090	6120DB	6130DB 6140DB 6160DA 6170DA	F-29	0	20	25	1	3	5		5		16				-	-
6085SK	6095	6125DB	6135DB 6145DB 6165DA 6175DA	F-29	0	20	25	1	3	5		5		16				-	-
6090SK	6100	6130DC	6140DC 6160DB 6170DB 6180DA	F-29	15	20	25	1	3	5	0	5	0	16	3.5		21	-	-
6095SK	6105	6135DC	6145DC 6165DB 6175DB 6185DA	F-29	15	20	25	1	3	5	0	5	0	16	3.5		21	-	-
-	610H	-		F-29	15	20	25	1	3	5	0	5	0	16	3.5	1		-	-
6100SK	6110	-		F-29	15	20	25	1	3	5		5		16				-	-
6105SK	6115	-		F-29	15	20	25	1	3	5		5		16				-	-
6110SK	6120	6160DC 6170DC 6190DA		F-32	18	32	35	-	3.5	6		6		25	-	-	28	-	-
6115SK	6125	6165DC	6175DC 6195DA 6205DA	F-32	18	32	35	-	3.5	6		6		25	-	-	28	-	-
-	612H	-		F-32	18	32	35	-	3.5	6		6		25	-	-	28	-	-
-	6130	6180DC 6190DB		F-32	22	38	40	-	3.5	6		6		32				-	-
-	6135	6185DB	6195DB 6205DB 6215DA 6255DA	F-32	22	38	40	-	3.5	6		6		32				-	-
-	6140	-		F-32	22	38	40	-	3.5	6		6		32			35	-	-
-	6145	-		F-32	22	38	40	-	3.5	6		6		32				-	-
-	614H	-		F-32	22	38	40	-	3.5	6		6		32				-	-
-	6160	6215DB		F-31	30	70	45	-	4	8	0	7		45	-	-	-	M10	20
-	6165	6215DB	6235DA 6245DA	F-31	30	70	45	-	4	8	-0.036	7		45	-	-	-	M10	20
-	616H	-		F-31	30	70	45	-	4	8		7		45	-	-	-	M10	20
-	6170	-		F-32	35	70	55	-	5	10		8	0	50	-	-	-	M12	25
-	6175	6255DB	6255DA	F-32	35	70	55	-	5	10		8	0	50	-	-	-	M12	25
-	6180	-		F-32	40	70	65	-	5	12		8	-0.090	63	-	-	-	M16	30
-	6185	6235DB	6245DB	F-32	40	70	65	-	5	12		8	-0.090	63	-	-	-	M16	30
-	6190	-		F-31	45	82	70	-	5.5	14	0	9		70	-	-	-	M16	30
-	6195	6255DB	6265DA 6275DA	F-31	45	82	70	-	5.5	14	0	9		70	-	-	-	M16	30
-	6205	-		F-31	45	82	82	-	5.5	14	-0.043	9		82	-	-	-	-	-
-	6215	-		F-31	50	82	82	-	5.5	14		9		82	-	-	-	-	-
-	6225	-		F-31	55	90	82	-	6	16		10		82	-	-	-	-	-
-	6235	-		F-31	60	110	105	-	7	18		11		105	-	-	-	-	-
-	6245	-		F-31	65	110	105	-	7	18		11	0	105	-	-	-	-	-
-	6255	-		F-31	80	130	130	-	9	22		14	-0.110	130	-	-	-	-	-
-	6265	-		F-31	80	130	130	-	9	22	0	14	-0.110	130	-	-	-	-	-
-	6275	-		F-32	90	140	150	-	9	25	-0.052	14		140	-	-	152.5	-	-

F TECHNICAL DATA

2. Motor

TECHNICAL
DATA

Motor

Terminal Box Specifications

1. Construction of Terminal Box

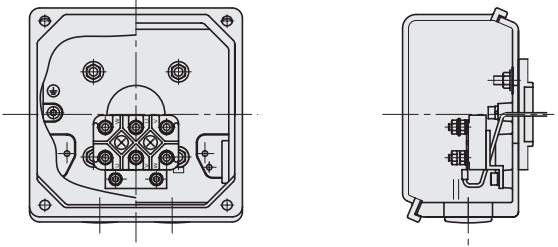
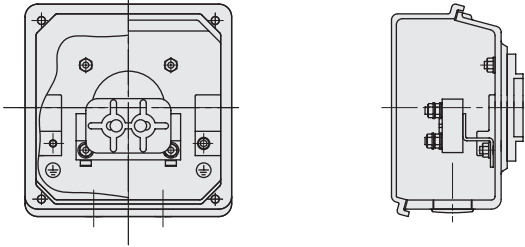
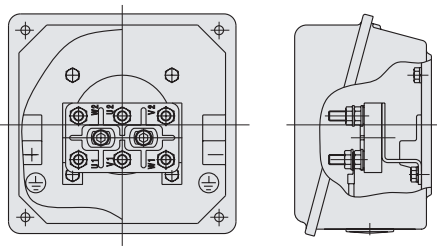
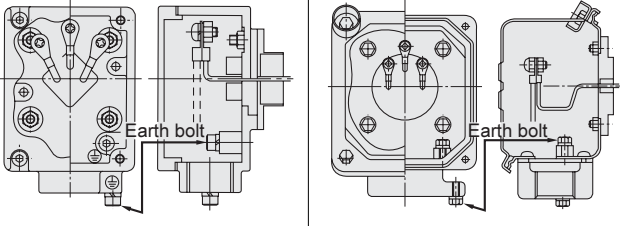
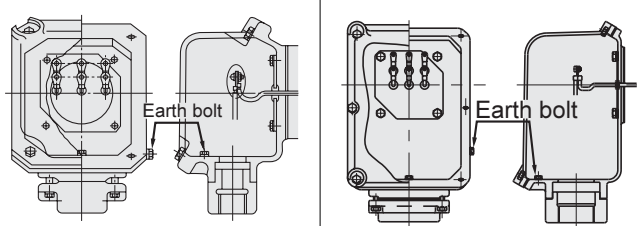
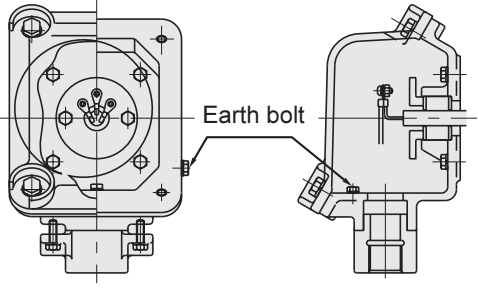
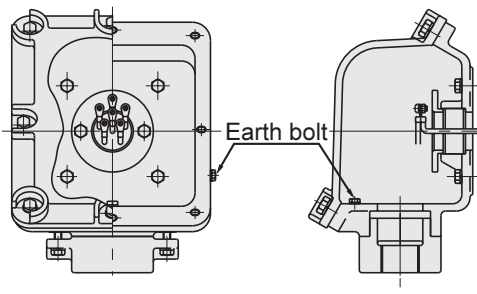
Standard Motors	3-Phase Motor AF Motor $0.1 \sim 5.5\text{kW} \times 4\text{P}$ $0.1 \sim 3.7\text{kW} \times 4\text{P}$		3-Phase Motor AF Motor $7.5 \sim 15\text{kW} \times 4\text{P}$ $5.5 \sim 11\text{kW} \times 4\text{P}$	
				
Increased Safety Motors	3-Phase Motor AF Motor $18.5 \sim 55\text{kW} \times 4\text{P}$ $15 \sim 55\text{kW} \times 4\text{P}$			
				
Flame Proof Motors	$0.1 \sim 0.4\text{kW} \times 4\text{P}$	$0.75 \sim 15\text{kW} \times 4\text{P}$	$18.5 \sim 37\text{kW} \times 4\text{P}$ $15 \sim 37\text{kW} \times 6\text{P}$	$45 \sim 55\text{kW} \times 4\text{P}$ $45 \sim 55\text{kW} \times 6\text{P}$
				
Flame Proof Motors	$0.1 \sim 3.7\text{kW} \times 4\text{P}$		$5.5 \sim 37\text{kW} \times 4\text{P}$ $15 \sim 37\text{kW} \times 6\text{P}$	
				

TECHNICAL DATA

Motor

Terminal Box Specifications

2. Methods for Drawing Lead Wire Outside of Terminal Box.

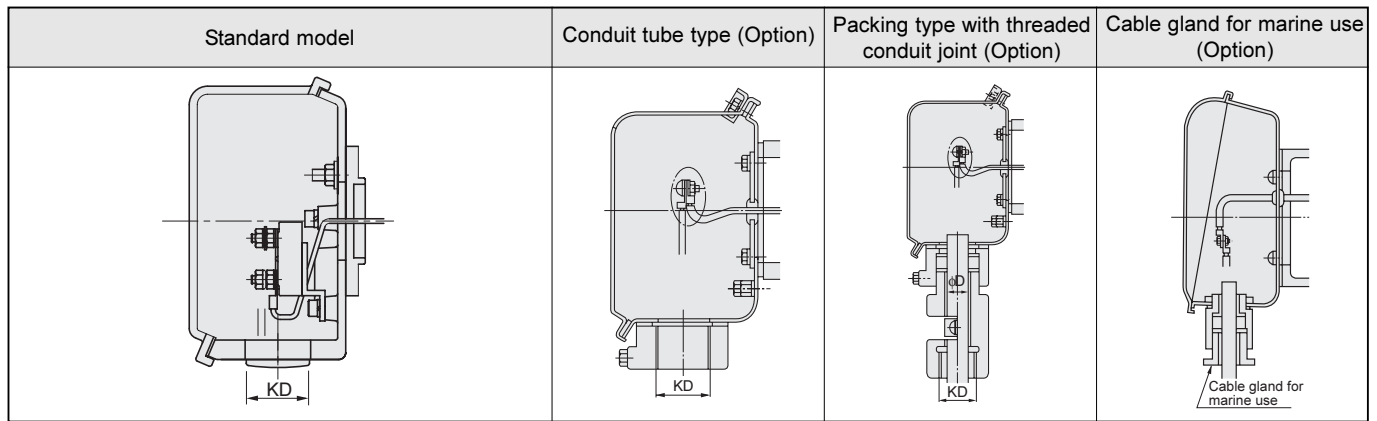

Motor			Standard Model KD	Option								
Capacity (kW)	3-Phase Motor	AF Motor		P	Conduit Tube Type		Packing Type with Thread Conduit Joint				Cable Gland for Marine Use	
					Standard Size KD	Available Size KD	Standard Size		Available Size		Standard Size	
						Thread KD	Cable Dia. φD	Thread KD	Cable Dia. φD	Thread KD	Cable Dia. φD	
0.1	-	-	4	M25	16 (PF1/2)	22 (PF3/4)	12.5	22 (PF3/4)	10.0~16.5	20c	15a-c	
0.2	0.1	-	4	M25								
0.25	-	-	4	M25								
0.4	0.2	-	4	M25								
0.55	-	-	4	M25	22 (PF3/4) 22 (PF3/4) 28 (PF1) 36 (PF1 1/4) Note:1	28 (PF1)	14.5	28 (PF1)	12.0~19.5	20c	20a-c	
0.75	0.4	-	4	M25								
1.1	-	-	4	M25								
1.5	0.75	-	4	M25								
2.2	1.5	-	4	M25	28 (PF1)	17.5	22 (PF3/4)	12.0~16.5	25c	20a-c		
3.0	-	-	4	M25								
3.7	2.2	-	4	M25								
5.5	3.7	-	4	M32								
7.5	5.5	-	4	M32	28 (PF1) 22 (PF3/4) 28 (PF1) 36 (PF1 1/4) 42 (PF1 1/2)	36 (PF1 1/4)	19.5	28 (PF1)	12.0~18.7	30a	25a-c	
11	7.5	-	4	M32								
15	11	-	4	M32								
15	-	-	6	M40								
18.5	-	-	4	M40	36 (PF1 1/4) 28 (PF1) 36 (PF1 1/4) 42 (PF1 1/2)	42 (PF1 1/2)	24	28 (PF1)	13.5~19.0	35a	25a-c	
18.5	-	-	6	M40								
22	15	-	4	M40								
22	15	-	6	M40								
30	22	-	4	M40	54 (PF2) 54 (PF2) 70 (PF2 1/2)	54 (PF2)	29	70 (PF2 1/2)	23.0~35.7	35a	30a-c	
30	22	-	6	M50								
37	30	-	4	M50								
37	30	-	6	M50								
45	37	-	4	M50	70 (PF2 1/2) 36 (PF1 1/4) 42 (PF1 1/2) 54 (PF2) 70 (PF2 1/2) 82 (PF3) 92 (PF3 1/2)	70 (PF2 1/2)	44	Note:2	29.0~45.0	55a	35a-c	
45	37	-	6	M50								
55	45	-	4	M50								
55	-	-	6	M63								

The size of the external lead wire opening of the standard Sumitomo motor has been listed.

- Notes:
1. In case of 0.4kW × 4Pole below (0.2kW × 4Pole below when AF motor for Inverter), Except for STD KD(PF1/2), dimensions of a terminal box become special.
 2. For the increased safety explosion-proof 45kw×4pole motor, the KD dimensions become PF11/4 (36) - PF31/2(92).
 3. Unless otherwise specifically requested, the outdoor type, increased safety explosion-proof motor and for maritime use will be manufactured to the standard dimensions specified above.
 4. Terminal Box below 0.4kW × 4P is plastic. Steel is also available. Please consult us.

TECHNICAL DATA

Motor

Terminal Box Specifications

3. Mounting Direction of Terminal Box

- The terminal box mounting direction can be changed in units of 90°, but specify the direction according to the following table when placing an order.

Cable port direction	Terminal box mounting position (As viewed from output shaft with motor being horizontal)	
	Left side (N33)	Right side (N34)
Type A (N3A)		
Type B (N3B)		
Type C (N3C)		
Type D (N3D)		

Cable port direction	Terminal box mounting position (As viewed from output shaft with motor being horizontal)	
	Top (N35)	Down (N36)
Type A (N3A)		
Type B (N3B)		
Type C (N3C)		
Type D (N3D)		

Note: Arrow indicates direction of lead wires out of terminal box.

4. Standard Position of Terminal Box and Direction of Lead Wires.

	Horizontal type(Horizontal Slow Speed Shaft)				Vertical type(Vertical Slow Speed Shaft Down)	
	Standard Motor		Brake Motor		Standard Motor	Brake Motor
	3-Phase	AF Motor	3-Phase	AF Motor	3-Phase	AF Motor
Terminal Box Mounting Position	Left side	Left side	Left side	Left side	Left side	Left side
Cable port direction	A	A	A	A	A	A

Terminal Box Specifications

5. Details of Motor Fan Cover Mounting

Refer to the dimensions FA or FB shown below when designing a gearmotor mounting space.

(1) Dimensions FA:.....Dimensions necessary to remove the fan cover or brake cover without removing the motor from the equipment.

(2) Dimensions FB:.....Minimum space required for adequate ventilation

- Note : 1. It is necessary to remove the gearmotor from the equipment when removing the fan or brake cover.
2. The minimum space when the wall at the back of the motor fan is closed tightly.
3. AF(Inverter) of 30kw or above are a differently ventilated type.

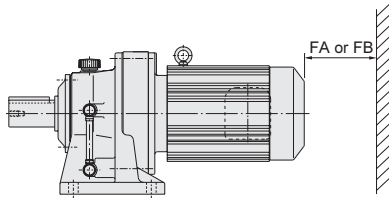

Dimension of FA and FB

Unit: mm

Specification	Without Brake				With Brake			
	3-Phase Motor		AF Motor		3-Phase Motor		AF Motor	
	FA	FB	FA	FB	FA	FB	FA	FB
0.1kW × 4P	-	-	48	20	49	-	61	20
0.2kW × 4P	48	20	48	20	61	20	61	20
0.25kW × 4P	48	20	-	-	61	20	-	-
0.4kW × 4P	48	20	49	20	61	20	93	20
0.55kW × 4P	49	20	-	-	93	20	-	-
0.75kW × 4P	49	20	52	20	93	20	115	20
1.1kW × 4P	52	20	-	-	115	20	-	-
1.5kW × 4P	52	20	56	20	115	20	121	20
2.2kW × 4P	56	20	60	20	121	20	132	20
3.0kW × 4P	60	20	-	-	132	20	-	-
3.7kW × 4P	60	20	60	20	132	20	132	20
5.5kW × 4P	60	20	75	25	132	20	170	25
7.5kW × 4P	75	25	75	25	170	25	170	25
11kW × 4P	75	25	130	30	170	25	220	30
15kW × 4P	130	30	155	30	220	30	367	30
18.5kW × 4P	155	30	170	30	367	30	370	30
22kW × 4P	155	30	170	30	367	30	370	30
30kW × 4P	170	30	140	30	370	30	295	30
37kW × 4P	230	30	140	30	445	30	295	30

6. Dimensions of Terminal Box Mounting Centers

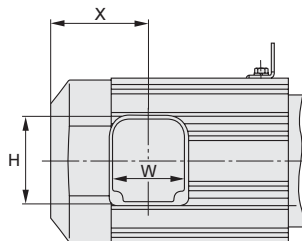

Unit: mm

Specification	Without Brake						With Brake					
	3-Phase Motor			AF Motor			3-Phase Motor			AF Motor		
	X	W	H	X	W	H	X	W	H	X	W	H
0.1kW×4P	35	125	126	59	125	126	70	125	126	91	125	126
0.2kW×4P	59	125	126	59	125	126	91	125	126	91	125	126
0.25kW×4P	59	125	126	-	-	-	91	125	126	-	-	-
0.4kW×4P	59	125	126	97	125	126	91	125	126	140	125	126
0.55kW×4P	97	125	126	-	-	-	140	125	126	-	-	-
0.75kW×4P	97	125	126	100	125	126	140	125	126	162	125	126
1.1kW×4P	100	125	126	-	-	-	162	125	126	-	-	-
1.5kW×4P	100	125	126	105	125	126	162	125	126	168	125	126
2.2kW×4P	105	125	126	127	125	126	168	125	126	199	125	126
3.0kW×4P	127	125	126	-	-	-	199	125	126	-	-	-
3.7kW×4P	127	125	126	127	125	126	199	125	126	199	125	126
5.5kW×4P	127	125	126	143	170	175	199	125	126	238	170	175
7.5kW×4P	143	170	175	143	170	175	238	170	175	238	170	175
11kW×4P	143	170	175	295	170	175	238	170	175	385	170	175
15kW×4P	295	170	175	340	229	223	385	170	175	550	229	223
18.5kW×4P	340	229	223	340	229	223	550	229	223	550	229	223
22kW×4P	340	229	223	340	229	223	550	229	223	550	229	223
30kW×4P	340	229	223	460	229	223	550	229	223	712	229	223
37kW×4P	430	229	223	460	229	223	645	229	223	712	229	223
45kW×4P	430	229	223	-	-	-	-	-	-	-	-	-
55kW×4P	465	229	223	-	-	-	-	-	-	-	-	-

Characteristics for Global Motor

Table F-27 Characteristics of Non-Explosion Proof Motors

(1) 200V Class

Motor Frame Size	Pole	4P														
	Power	220V-50Hz					230V-50Hz					220V-60Hz				
	Output power (kW)	Rated Current	Torque max.(%)	Starting Torque (%)	Starting Current (A)	Speed (r/min)	Rated Current	Torque max.(%)	Starting Torque (%)	Starting Current (A)	Speed (r/min)	Rated Current	Torque max.(%)	Starting Torque (%)	Starting Current (A)	Speed (r/min)
F-63S	0.10	0.60	235	230	2.3	1420	0.62	261	261	2.3	1430	0.53	220	202	2.1	1700
F-63M	0.20	1.0	210	206	3.8	1410	1.0	231	236	4.0	1420	0.95	186	191	3.5	1690
F-63M	0.25	1.2	182	195	4.2	1380	1.2	202	222	4.4	1400	1.2	153	161	3.7	1640
F-71M	0.40	2.0	200	201	7.3	1410	2.1	221	229	7.8	1400	1.8	188	185	6.6	1680
F-80S	0.55	2.4	182	206	9.2	1410	2.4	200	225	9.6	1420	2.3	164	166	8.6	1680
F-80M	0.75	3.3	211	193	13.1	1420	3.3	217	212	13.8	1430	3.1	189	180	12.3	1720
F-90S	1.1	4.7	215	200	21.7	1420	4.6	236	223	22.8	1420	4.4	189	170	19.9	1690
F-90L	1.5	6.1	204	192	27.9	1420	6.0	226	212	28.9	1430	5.7	196	175	25.5	1700
F-100L	2.2	8.7	203	213	42.1	1420	8.3	231	255	45.0	1430	8.1	207	185	38.0	1690
F-112S	3.0	11.2	205	213	61	1420	11.1	224	237	64	1420	10.8	175	155	54	1720
F-112M	3.7	13.4	219	218	80	1410	17.8	308	340	114	1440	12.9	207	178	70	1700

(2) 400V Class

Motor Frame Size	Pole	4P														
	Power	380V-50Hz					400V-50Hz					415V-50Hz				
	Output (kW)	Rated Current	Torque max.(%)	Starting Torque (%)	Starting Current (A)	Speed (r/min)	Rated Current	Torque max.(%)	Starting Torque (%)	Starting Current (A)	Speed (r/min)	Rated Current	Torque max.(%)	Starting Torque (%)	Starting Current (A)	Speed (r/min)
F-63S	0.10	0.34	235	230	1.3	1420	0.36	261	261	1.3	1430	0.37	281	286	1.4	1430
F-63M	0.20	0.61	210	206	2.2	1410	0.62	233	236	2.3	1420	0.63	251	260	2.4	1420
F-63M	0.25	0.70	182	195	2.4	1380	0.70	202	222	2.5	1380	0.70	220	242	2.3	1400
F-71M	0.40	1.2	200	201	4.2	1410	1.2	221	229	4.5	1420	1.3	236	250	4.7	1420
F-80S	0.55	1.4	182	206	5.3	1410	1.4	200	225	5.5	1420	1.4	218	248	5.8	1420
F-80M	0.75	1.9	211	193	7.6	1420	1.9	219	215	8.0	1430	2.0	237	232	8.4	1440
F-90S	1.1	2.7	215	200	12.5	1420	2.7	236	223	13.2	1420	2.7	256	243	14.3	1430
F-90L	1.5	3.5	204	192	16.1	1420	3.5	228	224	17.1	1430	3.6	242	236	17.8	1430
F-100L	2.2	5.0	203	213	24.3	1420	4.8	231	255	26.0	1430	5.0	240	263	26.8	1430
F-112S	3.0	6.5	205	213	35.1	1420	6.4	224	237	37.0	1420	6.2	241	255	35.7	1420
F-112M	3.7	7.8	219	218	45.9	1410	7.5	231	236	46.9	1420	7.7	259	269	51	1430
F-132S	5.5	11.3	215	227	69	1410	11.1	237	256	73	1420	11.0	256	281	76	1430
F-132M	7.5	15.0	228	232	93	1450	14.8	252	261	99	1450	14.8	270	284	103	1450
F-160M	11.0	21.5	231	250	139	1450	21.0	256	282	147	1450	20.8	274	308	154	1450
G-160L	15.0	27.7	241	235	170	1460	26.6	271	265	180	1470	26.0	294	289	188	1470
F-180MG	18.5	34.5	262	277	245	1450	33.1	293	312	261	1450	32.3	319	340	272	1460
F-180MG	22.0	40.8	252	269	280	1450	39.3	281	302	297	1450	38.9	304	328	310	1450
F-180L	30.0	56	218	236	325	1450	54	244	265	345	1450	54	264	286	361	1450
F-200L	37.0	70	256	285	479	1450	66	256	287	446	1460	65	277	311	467	1460
F-200L	45.0	84	251	286	564	1440	81	252	288	538	1450	80	271	310	559	1450

Motor Frame Size	Pole	4P				
	Power	440V-60Hz				
	Output (kW)	Rated Current	Torque max.(%)	Starting Torque (%)	Starting Current (A)	Speed (r/min)
F-63S	0.10	0.32	300	289	1.4	1730
F-63M	0.20	0.54	268	266	2.4	1720
F-63M	0.25	0.60	232	251	2.6	1700
F-71M	0.40	1.0	256	262	4.6	1730
F-80S	0.55	1.2	224	240	5.9	1720
F-80M	0.75	1.7	247	242	8.4	1740
F-90S	1.1	2.3	257	260	13.6	1720
F-90L	1.5	3.0	250	243	17.5	1740
F-100L	2.2	4.2	248	260	26.2	1720
F-112S	3.0	5.5	238	225	37.0	1720
F-112M	3.7	6.6	246	238	46.4	1720
F-132S	5.5	9.6	254	263	73	1720
F-132M	7.5	12.8	267	271	98	1750
F-160M	11.0	18.4	270	296	145	1750
G-160L	15.0	23.8	275	280	175	1770
F-180MG	18.5	29.6	295	324	252	1750
F-180MG	22.0	38.8	199	216	225	1720
F-180L	30.0	47.8	249	280	334	1740
F-200L	37.0	59	259	306	429	1730
F-200L	45.0	72	255	311	516	1730

Notes: 1. The characteristics of the 4-pole motor with built-in brake is the same as shown in Table F-27 (1) and (2).
 2. For the electrical current of the brakes, refer to Table F-31 on Page F-40.
 3. Because the values in the above table are subject to change without notice, please consult us if confirmed values are necessary.

TECHNICAL DATA
Motor

Characteristics for Global Motor

Table F-28 Characteristics of AF Motor for Inverters

Motor Frame Size	Pole	4P							
	Power	220V-60Hz				380V-60Hz			
	Output (kW)	Frequency (Hz)	Voltage (V)	Rated Current	Speed (r/min)	Frequency (Hz)	Voltage (V)	Rated Current	Speed (r/min)
FA-63S	0.10	60	220	0.85	1765	60	380	0.38	1755
		6.0	34.0	0.75	120	6.0	68	0.37	125
FA-63M	0.20	60	220	1.6	1760	60	380	0.69	1750
		6.0	34.0	1.5	130	6.0	68	0.75	130
FA-71M	0.40	60	220	2.4	1745	60	380	1.1	1725
		6.0	35.0	2.2	115	6.0	70	1.1	115
FA-80M	0.75	60	220	4.0	1755	60	380	1.9	1735
		6.0	31.0	3.9	120	6.0	62	1.9	120
FA-90L	1.5	60	220	6.4	1735	60	380	3.3	1705
		6.0	33.0	6.5	105	6.0	66	3.2	110
FA-100L	2.2	60	220	9.1	1755	60	380	4.7	1740
		6.0	31.0	9.3	140	6.0	62	4.6	135
FA-112M	3.7	60	220	14.0	1750	60	380	7.7	1730
		6.0	30.0	14.8	125	6.0	60	7.4	120
FA-132S	5.5	60	220	20.2	1760	60	380	11.2	1745
		6.0	30.0	21.3	135	6.0	60	10.7	130
FA-132M	7.5	60	220	27.4	1765	60	380	15.2	1750
		6.0	30.0	28.2	145	6.0	60	14.1	145
G-160L	11.0	60	220	38.5	1770	60	380	21.7	1755
		6.0	32.0	39.6	155	6.0	64	19.7	155
F-180MG	15.0	60	220	53	1780	60	380	30.3	1770
		6.0	32.0	53	165	6.0	64	26.3	165
F-180L	22.0	60	220	77	1775	60	380	44.5	1765
		6.0	32.0	79	160	6.0	64	39.4	160
BF-200L	30.0	60	220	100	1780	60	380	58	1770
		6.0	32.0	101	165	6.0	64	51	165
BF-200L	37.0	60	220	123	1775	60	380	72	1765
		6.0	30.0	123	165	6.0	64	62	165

Motor Frame Size	Pole	4P			
	Power	415V-60Hz			
	Output (kW)	Frequency (Hz)	Voltage (V)	Rated Current	Speed (r/min)
FA-63S	0.10	60	415	0.40	1760
		6.0	68	0.37	125
FA-63M	0.20	60	415	0.75	1760
		6.0	68	0.75	130
FA-71M	0.40	60	415	1.1	1740
		6.0	70	1.1	115
FA-80M	0.75	60	415	1.9	1745
		6.0	62	1.9	120
FA-90L	1.5	60	415	3.1	1725
		6.0	66	3.2	110
FA-100L	2.2	60	415	4.4	1750
		6.0	62	4.6	135
FA-112M	3.7	60	415	7.2	1745
		6.0	60	7.4	120
FA-132S	5.5	60	415	10.5	1755
		6.0	60	10.7	130
FA-132M	7.5	60	415	14.2	1760
		6.0	60	14.1	145
G-160L	11.0	60	415	20.1	1765
		6.0	64	19.7	155
F-180MG	15.0	60	415	27.8	1775
		6.0	64	26.3	165
F-180L	22.0	60	415	40.7	1770
		6.0	64	39.4	160
BF-200L	30.0	60	415	53	1775
		6.0	64	51	165
BF-200L	37.0	60	415	65	1775
		6.0	64	62	165

Notes: Because the values in the above table are subject to change without notice, please consult us if confirmed values are necessary.

Characteristics for Japan Standard Motor

Table F-29 Characteristics of 6P Motors

(1) 200V Class

Motor Frame Size	Pole Power Output power (kW)	6P														
		200V-50Hz					200V-60Hz					220V-60Hz				
		Rated Current	Torque max.(%)	Starting Torque (%)	Starting Current (A)	Speed (r/min)	Rated Current	Torque max.(%)	Starting Torque (%)	Starting Current (A)	Speed (r/min)	Rated Current	Torque max.(%)	Starting Torque (%)	Starting Current (A)	Speed (r/min)
F-63M	0.1	0.72	213	200	2.4	940	0.64	194	172	2.2	1120	0.65	240	221	2.4	1140
F-71M	0.2	1.6	296	289	5.8	940	1.3	260	243	5.3	1140	1.4	325	312	6.0	1150
F-71M	0.25	1.7	232	226	5.8	920	1.4	205	190	5.3	1120	1.5	257	247	6.0	1130
F-80M	0.40	2.6	240	235	9.3	930	2.3	215	199	8.7	1100	2.3	265	256	9.7	1130
F-80ML	0.55	3.4	245	257	12.0	920	3.0	220	218	11.1	1100	3.0	274	282	12.4	1120
F-90L	0.75	4.5	240	228	17.8	930	4.0	212	196	16.3	1110	4.0	265	254	18.4	1130
F-90LL	1.1	6.0	260	265	25.3	930	5.3	222	216	23.1	1110	5.2	278	280	26.0	1130
F-100L	1.5	7.7	247	244	36.2	940	7.0	202	191	32.5	1120	6.8	261	247	36.6	1140
F-112M	2.2	(11.1)	(248)	(222)	(62.3)	(950)	(9.9)	(205)	(175)	(54.5)	(1140)	(9.5)	(263)	(226)	(61.5)	(1150)
F-132SS	3.0	(14.9)	(242)	(217)	(82.7)	(950)	(13.4)	(200)	(173)	(72.4)	(1140)	(12.8)	(257)	(223)	(81.7)	(1150)
F-132S	3.7	(17.7)	(235)	(220)	(98.1)	(950)	(16.3)	(190)	(170)	(85.1)	(1140)	(15.3)	(239)	(221)	(96.2)	(1150)
F-132M	5.5	(25.8)	(239)	(232)	(149)	(960)	(23.7)	(190)	(175)	(126)	(1150)	(22.2)	(246)	(228)	(143)	(1160)
F-160M	7.5	30.3	246	254	174	980	28.7	197	213	150	1180	26.8	251	272	165	1180
F-160L	11.0	43.4	245	263	250	970	41.3	194	219	216	1170	38.4	247	280	244	1170
F-180MG	15.0	55	271	232	358	980	55	222	195	308	1180	49.9	276	246	344	1180
F-180L	18.5	71	311	274	500	990	66	258	234	430	1180	62	321	293	480	1190
F-180L	22.0	83	261	230	500	990	79	216	196	430	1180	73	269	246	480	1180
F-200L	30.0	111	269	267	694	960	106	221	228	598	1180	98	275	287	668	1180
F-200L	37.0	137	289	293	912	980	130	237	251	784	1170	120	296	314	878	1170
F-225S	45.0	163	238	244	962	980	158	195	209	818	1170	144	242	262	914	1180
F-250S	55	198	231	242	1146	980	194	188	208	970	1170	176	234	260	1084	1180
F-250M	75	269	271	296	1830	980	261	221	255	1536	1170	239	274	320	1718	1180

(2) 400V Class

Motor Frame Size	Pole Power Output (kW)	6P														
		400V-50Hz					400V-60Hz					440V-60Hz				
		Rated Current	Torque max.(%)	Starting Torque (%)	Starting Current (A)	Speed (r/min)	Rated Current	Torque max.(%)	Starting Torque (%)	Starting Current (A)	Speed (r/min)	Rated Current	Torque max.(%)	Starting Torque (%)	Starting Current (A)	Speed (r/min)
F-63M	0.10	0.36	213	200	1.2	940	0.32	194	172	1.1	1120	0.33	240	221	1.2	1140
F-71M	0.20	0.81	296	289	2.9	940	0.64	260	243	2.7	1140	0.69	325	312	3.0	1150
F-71M	0.25	0.87	232	226	2.9	920	0.72	205	190	2.7	1120	0.75	257	247	3.0	1130
F-80M	0.40	1.3	240	235	4.7	930	1.2	215	199	4.4	1100	1.2	265	256	4.9	1130
F-80ML	0.55	1.7	245	257	6.0	920	1.5	220	218	5.6	1100	1.5	274	282	6.2	1120
F-90L	0.75	2.3	240	228	8.9	930	2.0	212	196	8.2	1110	2.0	265	254	9.2	1130
F-90LL	1.10	3.0	260	265	12.7	930	2.7	222	216	11.6	1110	2.6	278	280	13.0	1130
F-100L	1.5	3.9	247	244	18.1	940	3.5	202	191	16.3	1120	3.4	261	247	18.3	1140
F-112M	2.2	(5.6)	(248)	(222)	(31.2)	(950)	(5.0)	(205)	(175)	(27.3)	(1140)	(4.8)	(263)	(226)	(30.75)	(1150)
F-132SS	3.0	(7.5)	(242)	(217)	(41.4)	(950)	(6.7)	(200)	(173)	(36.2)	(1140)	(6.4)	(257)	(223)	(40.85)	(1150)
F-132S	3.7	(8.9)	(235)	(220)	(49.1)	(950)	(8.2)	(190)	(170)	(42.6)	(1140)	(7.7)	(239)	(221)	(48.1)	(1150)
F-132M	5.5	(12.9)	(239)	(232)	(74)	(960)	(11.9)	(190)	(175)	(63.3)	(1150)	(11.1)	(246)	(228)	(71.7)	(1160)
F-160M	7.5	15.2	246	254	87	980	14.4	197	213	75	1180	13.4	251	272	83	1180
F-160L	11.0	21.7	245	263	125	970	20.6	194	219	108	1170	19.2	247	280	122	1170
F-180MG	15.0	27.7	271	232	179	980	27.3	222	195	154	1180	25.0	276	246	172	1180
F-180L	18.5	35.6	311	274	250	990	33.2	258	234	215	1180	31.1	321	293	240	1190
F-180L	22.0	41.4	261	230	250	990	39.5	216	196	215	1180	36.3	269	246	240	1180
F-200L	30.0	56	269	267	347	960	53	221	228	299	1180	48.8	275	287	334	1180
F-200L	37.0	68	289	293	456	980	65	237	251	392	1170	60	296	314	439	1170
F-225S	45.0	82	238	244	481	980	79	195	209	409	1170	72	242	262	457	1180
F-250S	55	99	231	242	573	980	97	188	208	485	1170	88	234	260	542	1180
F-250M	75	135	271	296	915	980	131	221	255	768	1170	119	274	266	859	1180

Notes: 1. Values in parenthesis in the above table is designed value. Consult us for detailed values.
2. Because the values in the above table are subject to change without notice, please consult us if confirmed values are necessary.

TECHNICAL DATA
Motor

Characteristics for Japan Standard Motor

Table F-30 Characteristics of Increased Safety Motors

(1) 200V Class

Motor Frame Size	Pole	4P														
	Power	200V-50Hz					200V-60Hz					220V-60Hz				
	Output (kW)	Rated Current	Torque max.(%)	Starting Torque (%)	Starting Current (A)	Speed (r/min)	Rated Current	Torque max.(%)	Starting Torque (%)	Starting Current (A)	Speed (r/min)	Rated Current	Torque max.(%)	Starting Torque (%)	Starting Current (A)	Speed (r/min)
F-63S	0.10	0.69	265	281	2.7	1420	0.60	236	245	2.5	1690	0.62	285	297	2.8	1720
F-63M	0.20	1.2	232	233	4.6	1410	1.1	210	207	4.2	1690	1.1	254	250	4.8	1710
F-71M	0.40	2.3	237	237	9.1	1380	2.0	210	210	8.3	1650	2.0	257	257	9.4	1680
F-80M	0.75	3.9	234	215	16.0	1420	3.4	211	190	15.1	1720	3.3	253	242	16.8	1740
F-90L	1.5	7.0	242	224	34.1	1430	6.3	205	192	31.2	1710	6.0	250	243	34.9	1730
F-100L	2.2	9.6	268	255	52	1430	8.8	229	204	46.9	1700	8.3	282	260	52	1720
F-112M	3.7	15.1	262	236	94	1430	14.2	216	188	83	1710	13.1	264	238	93	1730
F-132S	5.5	22.9	313	286	158	1420	21.1	264	229	139	1700	19.7	325	291	156	1720
F-132M	7.5	29.5	274	261	198	1450	27.4	240	224	175	1750	25.6	292	271	195	1760
F-160M	11.0	41.9	305	297	302	1450	39.5	263	247	265	1740	36.7	322	309	296	1750
G-160L	15.0	53	271	265	360	1460	52	220	222	313	1750	48	275	280	349	1760
F-180LG	18.5	66	293	312	522	1480	65	236	257	450	1780	59	295	324	504	1780
F-180LG	22.0	79	246	262	522	1480	78	199	216	450	1770	70	248	272	504	1780
F-200LG	30.0	105	245	281	706	1470	105	195	231	610	1760	94	245	292	684	1770
F-200L	37.0	128	245	289	857	1470	128	195	241	742	1750	115	245	305	832	1760
F-225S	45.0	154	243	228	985	1470	154	198	193	844	1770	139	246	241	943	1770
F-225S	55	186	267	261	1328	1470	186	217	225	1130	1770	168	269	280	1261	1770

Motor Frame Size	Pole	6P														
	Power	200V-50Hz					200V-60Hz					220V-60Hz				
	Output (kW)	Rated Current	Torque max.(%)	Starting Torque (%)	Starting Current (A)	Speed (r/min)	Rated Current	Torque max.(%)	Starting Torque (%)	Starting Current (A)	Speed (r/min)	Rated Current	Torque max.(%)	Starting Torque (%)	Starting Current (A)	Speed (r/min)
F-180LG	15.0	56	271	232	358	980	55	222	195	308	1180	50	276	246	344	1180
F-180L	18.5	72	311	274	500	990	67	258	234	430	1180	63	321	293	480	1190
F-180L	22.0	84	261	230	500	990	79	216	196	430	1180	73	269	246	480	1180
F-200L	30.0	107	252	253	652	980	107	204	212	558	1170	97	256	287	668	1170
F-225S	37.0	136	239	241	793	980	132	196	206	678	1170	121	243	314	878	1180
F-225S	45.0	163	235	245	946	970	163	190	208	809	1170	146	237	262	914	1170
F-250S	55	199	242	257	1184	970	198	196	219	1011	1170	178	244	260	1084	1180

(2) 400V Class

Motor Frame Size	Pole	4P														
	Power	400V-50Hz					400V-60Hz					440V-60Hz				
	Output (kW)	Rated Current	Torque max.(%)	Starting Torque (%)	Starting Current (A)	Speed (r/min)	Rated Current	Torque max.(%)	Starting Torque (%)	Starting Current (A)	Speed (r/min)	Rated Current	Torque max.(%)	Starting Torque (%)	Starting Current (A)	Speed (r/min)
F-63S	0.10	0.36	255	261	1.3	1420	0.31	233	224	1.2	1700	0.32	277	289	1.4	1720
F-63M	0.20	0.62	233	236	2.3	1410	0.54	212	202	2.1	1690	0.54	257	266	2.4	1710
F-71M	0.40	1.2	229	229	4.5	1390	1.0	205	201	4.1	1650	1.0	249	262	4.6	1680
F-80M	0.75	1.9	234	215	8.0	1420	1.7	211	190	7.6	1720	1.7	253	242	8.4	1740
F-90L	1.5	3.5	242	224	17.1	1430	3.1	205	192	15.6	1710	3.0	250	243	17.5	1730
F-100L	2.2	4.8	268	255	26.0	1430	4.4	229	204	23.5	1700	4.2	282	260	26.2	1720
F-112M	3.7	7.5	262	236	46.9	1430	7.1	216	188	41.4	1710	6.6	264	238	46.4	1730
F-132S	5.5	11.4	313	286	79	1420	10.5	264	229	70	1700	9.9	325	291	78	1720
F-132M	7.5	14.8	274	261	99	1450	13.7	240	224	88	1750	12.8	292	271	98	1760
F-160M	11.0	21.0	305	297	151	1450	19.7	263	247	133	1740	18.3	322	309	148	1750
G-160L	15.0	26.8	271	265	180	1460	26.1	220	222	157	1750	23.8	275	280	175	1760
F-180LG	18.5	33.1	293	312	261	1480	32.3	236	257	225	1780	29.6	295	324	252	1780
F-180LG	22.0	39.3	246	262	261	1480	38.8	199	216	225	1770	35.1	248	272	252	1780
F-200LG	30.0	52	245	281	353	1470	53	195	231	305	1760	47.2	245	292	342	1770
F-200L	37.0	64	245	289	429	1470	64	195	241	371	1750	58	245	305	416	1760
F-225S	45.0	77	243	222	492	1470	77	198	193	422	1770	70	246	241	471	1770
F-225S	55	93	267	261	664	1470	93	217	225	565	1770	84	269	280	630	1770

Motor Frame Size	Pole	6P														
	Power	400V-50Hz					400V-60Hz					440V-60Hz				
	Output (kW)	Rated Current	Torque max.(%)	Starting Torque (%)	Starting Current (A)	Speed (r/min)	Rated Current	Torque max.(%)	Starting Torque (%)	Starting Current (A)	Speed (r/min)	Rated Current	Torque max.(%)	Starting Torque (%)	Starting Current (A)	Speed (r/min)
F-180LG	15.0	27.9	271	232	179	980	27.3	222	195	154	1180	25.0	276	246	172	1180
F-180L	18.5	36.0	311	274	250	990	33.4	258	234	215	1180	31.3	321	293	240	1190
F-180L	22.0	41.9	261	230	250	990	39.7	216	196	215	1180	36.5	269	246	240	1180
F-200L	30.0	54	252	253	326	980	53	204	212	279	1170	48.4	256	269	313	1170
F-225S	37.0	68	239	241	396	980	66	196	206	339	1170	60	243	258	379	1180
F-225S	45.0	81	235	245	473	970	81	190	208	404	1170	73	237	261	453	1170
F-250S	55	99	242	257	592	970	99	196	219	506	1170	89	244	275	566	1180

*Because the values in the above table are subject to change without notice, please consult us if confirmed values are necessary.

Specification and Constructions of Built-in Brake

Table F-31 Standard Brake Motor Specification

Output Power (kW × 4P)		Brake Type	Standard Torque (N · m)	Moment of Inertia (× 10 ⁻⁴ kg·m ²)	Total Braking Energy (× 10 ³ J)	Motion Delay Time (sec)		Brake Current (A)					
General-Purpose Motors	AF Motor					Standard Braking Action	Fast Braking Action	220V	230V	380V	400V	415V	440V
0.10		FB-01A	1.0	3.5	12	0.15~0.20	0.015~0.02	0.08	0.10	-	-	-	-
0.20/0.25	0.10	FB-02A	2.0	5.5	12			0.10	0.10	-	-	-	-
0.40	0.20	FB-05A	4.0	6.75	12	0.10~0.150	0.01~0.015	0.10	0.10	-	-	-	-
0.55/0.75	0.40	FB-1B	7.5	11.1/13	33	0.20~0.30	0.01~0.02	0.10	0.10	-	-	-	-
1.1/1.5	0.75	FB-2B	15	20.8/23.5	38			0.30	0.30	-	-	-	-
2.2	1.5	FB-3B	22	37.3	45	0.30~0.40	0.01~0.02	0.30	0.30	-	-	-	-
3.0/3.7	2.2	FB-5B	37	81/95.8	235	0.40~0.50		0.60	0.60	-	-	-	-
5.5	3.7	FB-8B	55	125	235	0.30~0.40	0.03~0.04	-	-	0.30	0.30	0.30	0.30
7.5	5.5	FB-10B	75	303	343	0.70~0.80		-	-	0.30	0.40	0.40	0.40
11	7.5	FB-15B	110	410	343	0.50~0.60	0.10~0.15	-	-	0.40	0.40	0.40	0.40
15	11	CMB-20	100	1350	304	0.40~0.50		-	-	1.6	1.6	1.7	1.8
22	15	*1 ESB-220	150	2370	201	-	0.08	0.95	*2				
30	22	*1 ESB-220	200	2572	201	-		0.95					
37	30	*1 ESB-250	250	3205	262	-	0.07	1.15					

*1. Continuous rating applies to both motor and brake of the FB, CMB and ESB brakes, but continuous operation is impossible with vertical and inverted 4P input of the ESB type brake.

*2. ESB type brake comes in a 200V class only. When the power supply is 400V, use a transformer. The capacity of the transformer is 250-300 VA and the secondary voltage is 200-220V.

- The rectifier of the ESB type brake is to be placed separately. Use a special DC power unit (HD-110M3) for the ESB brake. (See p.F-43 of the rectifier.) The DC power unit is made as an indoor type. Install it in a place where it will not be splashed by water.
- Nonasbestos lining is used for the FB brake.
- When greater stopping accuracy is desired or brake is used for lifter, use the fast braking action.
- Low-noise type brakes are also available as an option.
- FB, CMB, and ESB brakes need DC power supply, and the spring braking system (non-electromagnetic braking system) is adopted.

Output Voltage of Rectifier (FB Brake)

Input Voltage	Output Voltage
AC220V	DC99V
AC230V	DC104V
AC380V	DC171V
AC400V	DC180V
AC415V	DC187V
AC440V	DC198V

* Refer to p.F-43 for the output voltage of ESB brake.

Why fast braking circuit shortens braking time.

See Fig.F-33 and Fig.F-34 for differences between standard braking circuit and fast braking circuit. See Fig.F-35 and Fig.F-36 for current curves of standard braking and fast braking.

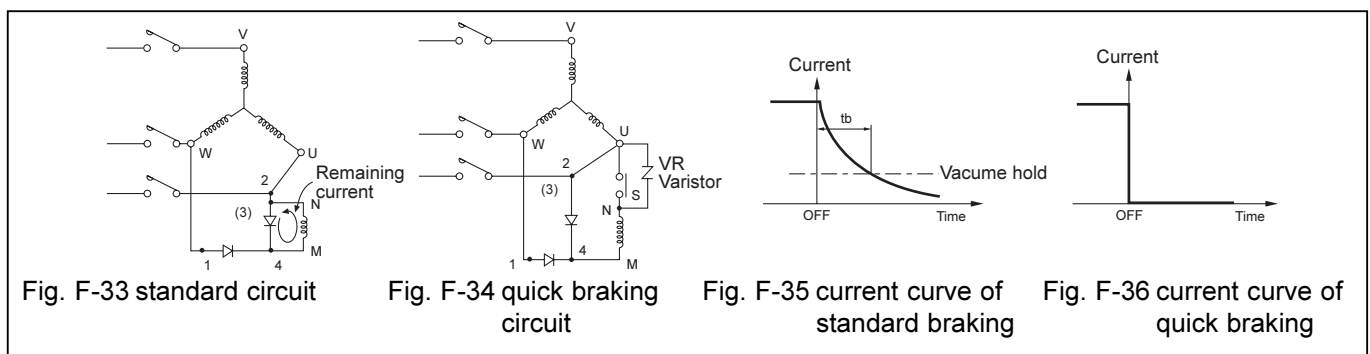

In the standard circuit Shown in Fig.F-33, some current remains after the power is turned off due to the saved energy in the inductance L of brake coil. The current curve is shown in the Fig.F-35. When it is connected to fast braking circuit as Show in Fig.F-34 and S is released at the same time, no current remains as there

is no closed circuit with the brake coil. (See the Fig.F-36) Therefore, it shortens the braking time by t_b in the Fig.F-35. Fast braking circuit is to release all current by ON/OFF of brake coil at the same time with power ON/OFF. (VR varistor must be used to protect the rectifier and connection S.)

Circuit in the rectifier

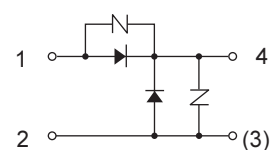

Specification and Constructions of Built-in Brake

Fig. F-37 FB-01A, 02A, 05A
(FB-01A without Fan)

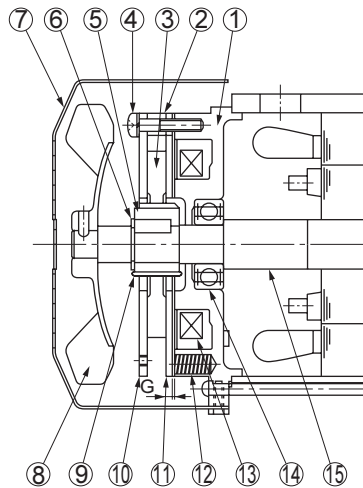

No.	Pats Name
1	Stationary core
2	Spacer
3	Brake lining
4	Assembling bolt
5	Boss
6	Shaft retaining C-ring
7	Cove
8	Fan (except for 0.1kW x 4 Poles)
9	Leaf spring
10	Fixed plate
11	Armature plate
12	Spring
13	Electromagnetic coil
14	Ball bearing
15	Motor shaft

*Brake release unit is available by option.

Fig. F-38 FB-1B, 2B, 3B

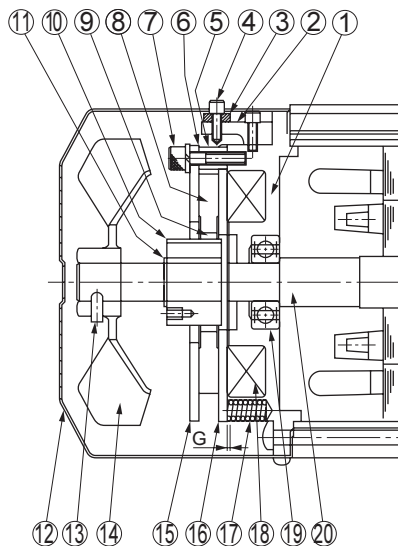

No.	Pats Name
1	Stationary core
2	Release fitting
3	Manual release protection spacer
4	Brake release bolt
5	Spacer
6	Gap adjusting shim
7	Assembling bolt
8	Brake lining
9	Leaf spring
10	Boss
11	Shaft retaining C-ring
12	Cover
13	Fan set bolt
14	Fan
15	Fixed plate
16	Armature plate
17	Spring
18	Electromagnetic coil
19	Ball bearing
20	Motor shaft

Fig. F-39 FB-5B, 8B

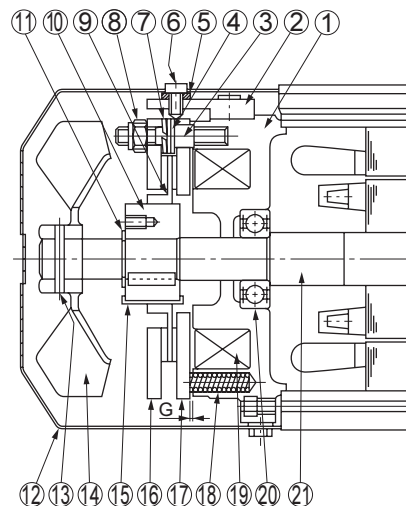

No.	Pats Name
1	Stationary core
2	Release fitting
3	Stud bolt
4	Adjusting washer
5	Manual release protection spacer
6	Brake release bolt
7	Spring washer
8	Gap adjusting nut
9	Brake lining
10	Boss
11	Shaft retaining C-ring
12	Cover
13	Spring pin
14	Fan
15	Leaf spring
16	Fixed plate
17	Armature plate
18	Spring
19	Electromagnetic coil
20	Ball bearing
21	Motor shaft

TECHNICAL DATA

Motor

Specification and Constructions of Built-in Brake

Fig. F-40 FB-10B, 15B

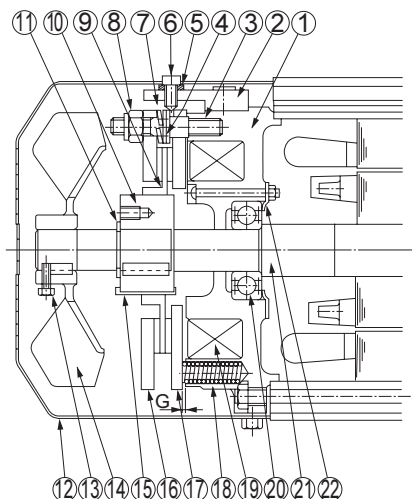

No.	Pats Name
1	Stationary core
2	Release fitting
3	Stud bolt
4	Adjusting washer
5	Manual release protection spacer
6	Brake release bolt
7	Spring washer
8	Gap adjusting nut
9	Brake lining
10	Boss
11	Shaft retaining C-ring
12	Cover
13	Fan set bolt
14	Fan
15	Leaf spring
16	Fixed plate
17	Armature plate
18	Spring
19	Electromagnetic coil
20	Ball bearing
21	Motor shaft
22	Bearing cover

Fig. F-41 CMB-20

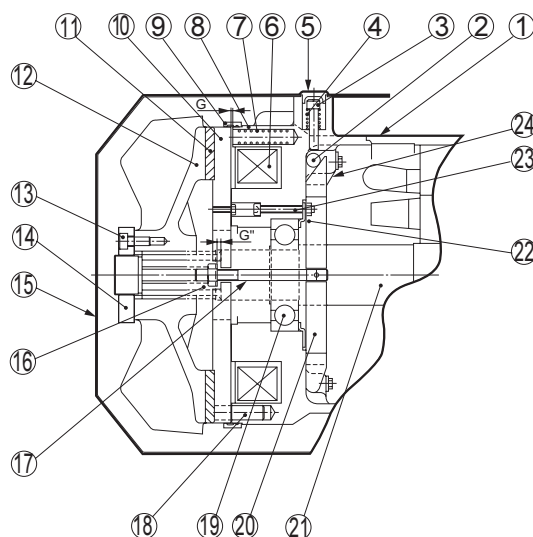

No.	Pats Name
1	Motor
2	Roller
3	Brake release bolt
4	Auxiliary spring
5	Plug
6	Electromagnetic coil
7	Spring
8	Stationary core
9	Dust seal
10	Armature plate
11	Brake lining
12	Brake wheel
13	Bolt
14	Retaining nut
15	Cover
16	U nut
17	Stud bolt
18	Retaining pin
19	Ball bearing
20	Release lever
21	Motor shaft
22	Bearing cover
23	Bearing cover bolt
24	Release lever stopper

TECHNICAL
DATA

Motor

Specification and Constructions of Built-in Brake

Fig. F-42. ESB220, 250

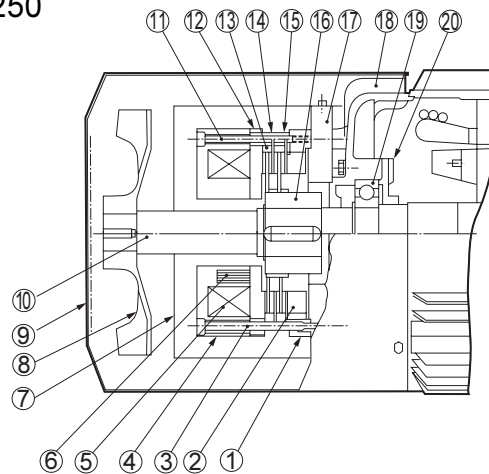

No.	Pats Name
1	Center ring
2	Gap adjusting screw
3	Assembling bolt
4	Field
5	Brake coil
6	Actuating spring
7	Brake cover (not provided for indoor type)
8	Fan
9	Fan cover
10	Shaft
11	Lock bolt
12	Armature
13	Inner disc
14	Outer disc
15	Spacer bushing
16	Hub
17	Brake adapter plate
18	Opposite drive end bracket
19	Opposite drive end bearing
20	Opposite drive end bearing cover

Power Module
Model HD-110M3

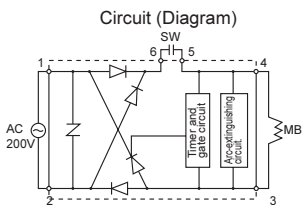
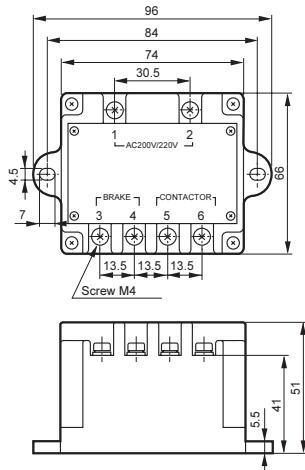

Rated input voltage: AC200/220V 50/60Hz
 Maximum input voltage: AC240V 50/60Hz
 Minimum input voltage: AC170V 50/60Hz

Standard output voltage
 Instantaneous voltage: DC180V with AC200V input
 Steady voltage: DC90V

Maximum output current: DC1.8A (Steady output)

Overexcitation time: 0.4 to 1.2 sec

Insulation resistance: At 100MΩ or above
 (When measured with 1000V megohmmeter)

Insulation with stand voltage: Application of AC2000V for over 1 time

Maximum frequency
 Inching (On-time 1.2 sec or less), 8 cycle/min
 Constant (On-time over 1.2sec), 30 cycle/min

Ambient temperature: -20°C ~ +60°C

Note: 1. Take care to avoid dust and water.
 2. Transformer is necessary for operation with 400V class power source.
 The transformer should have 250 ~ 300VA rating and 200 ~ 220V secondary voltage.

TECHNICAL DATA

Motor

Connection

3-Phase Induction Motor

		Wiring	Connection & Terminal code	Remarks
Direct Start-up				Standard motor under 0.1 - 3.7kW 200V Class 220 - 240V 50Hz 220V 60Hz
				Standard motor 0.1 - 3.7kW 400V Class 380 - 420V 50Hz 440V 60Hz
Start-up	λ - Δ Start-up		Start-up time λ Connection 	Standard Motor (1) Capacity: 5.5kW and more (2) Power Source 400V Class 380 - 420V 50Hz 400V 60Hz
			After full acceleration Δ Connection 	Note: If other than the above-mentioned voltages, please consult us.

TECHNICAL DATA
Motor

Example of Connection

a. 3-Phase Motor

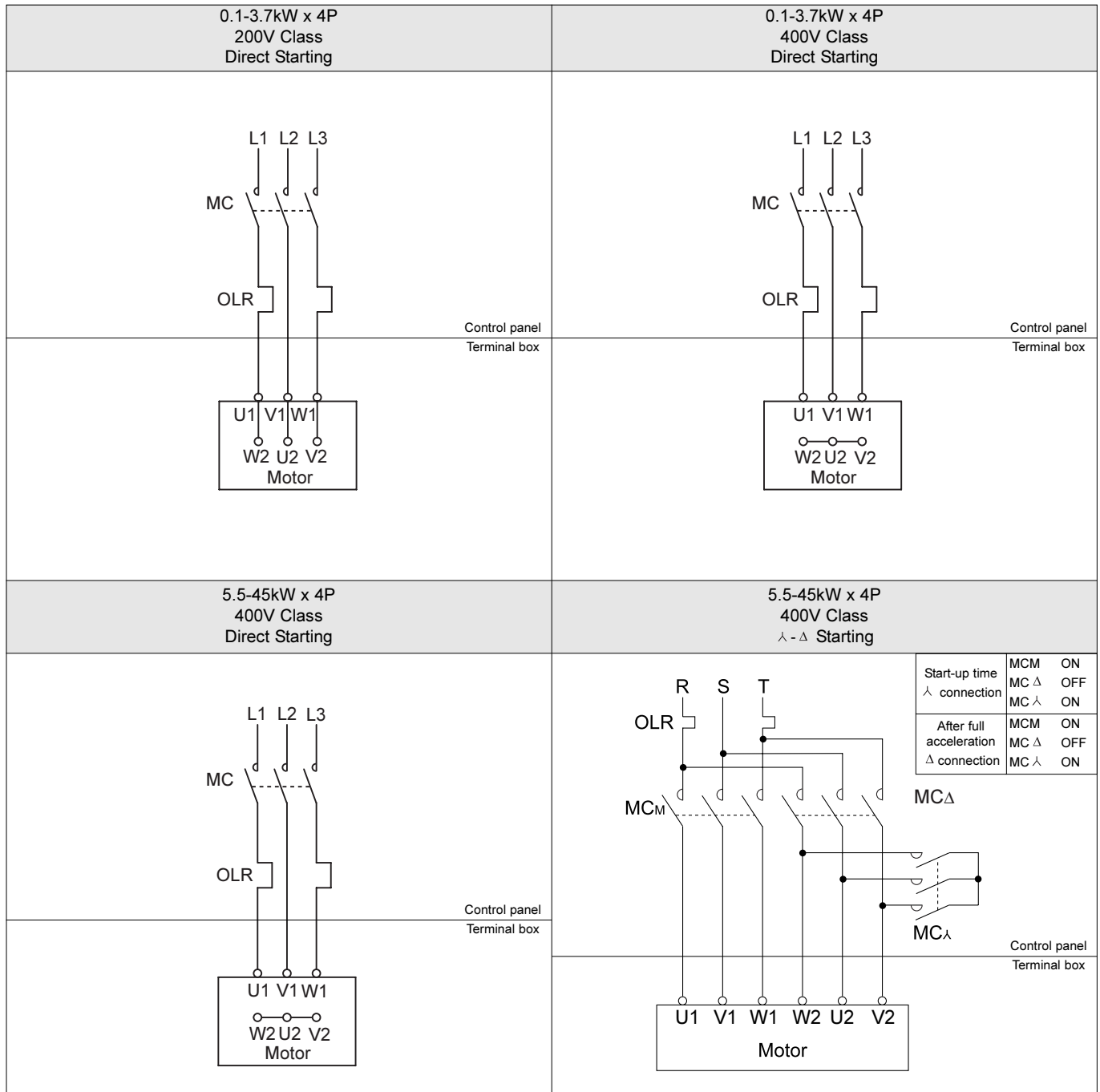

TECHNICAL DATA
Motor

MC: Electromagnetic contactor and
OLR: Overload relay or thermal relay are not supplied by Sumitomo.

Example of Connection

b. 3-Phase Motor

Example of connection for inverter-driving

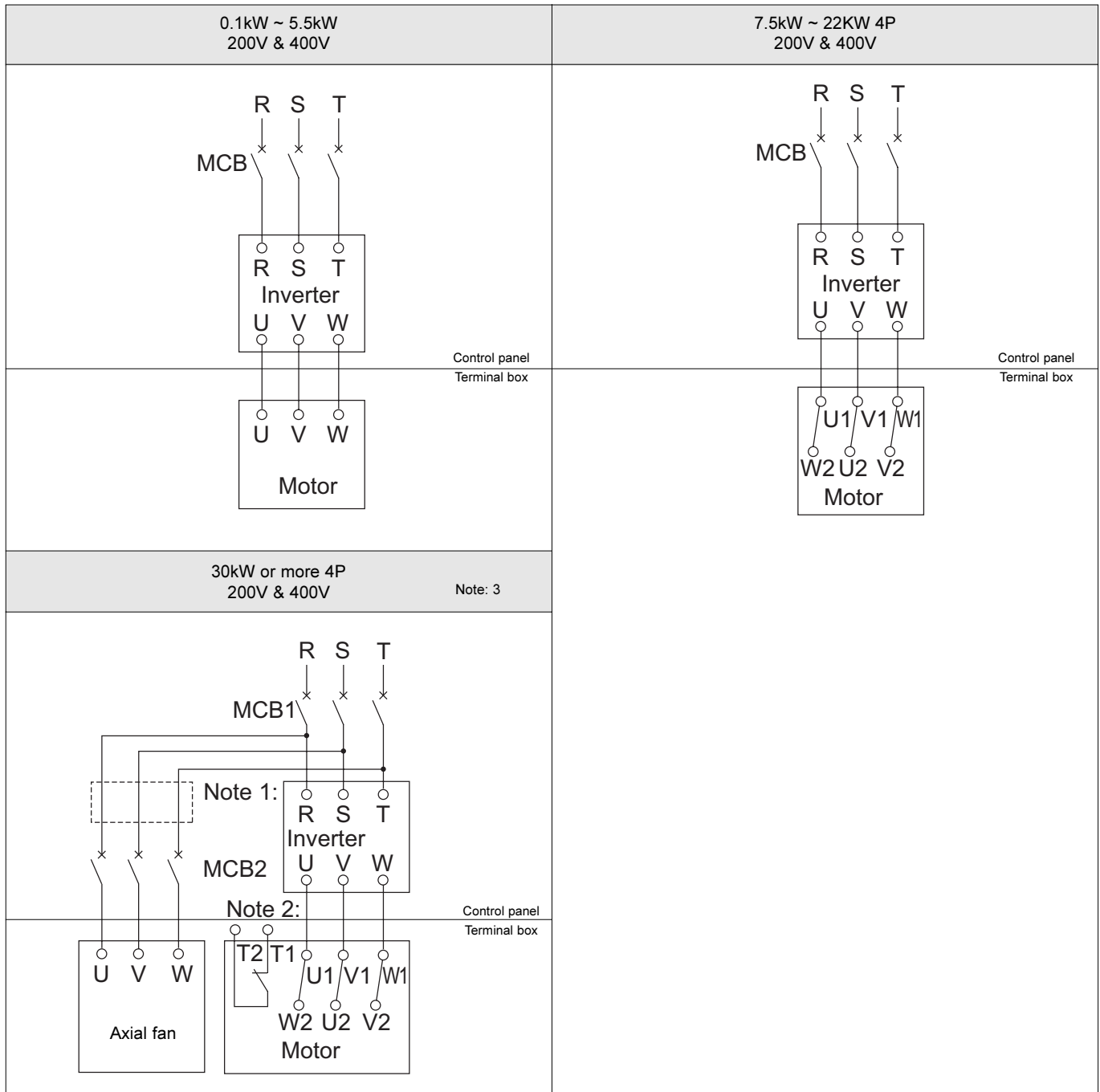

TECHNICAL DATA
Motor

The AF motor is designed for inverter-driving. When the capacity is small, the λ connection is adopted, and when it is intermediate or larger, the Δ connection is adopted.
- λ - Δ change-over operation by commercial power will also be possible.

- Note:
1. The standard voltage of the axial fan is 3 ,200V. Provide a 400/200V transformer for the 400V power supply. Contact us for inquiries about a 400V fan.
 2. Thermostat specifications (For totally enclosed separate ventilation type)
Terminal code: T1 and T2 or P1 and P2
Operating temperature: 135°C (Type F insulation)
Operation: Normally closed (b contact point)
Max. current: 24VDC; 18A; 230VAC ; 13A
 3. General motor of standard specification type does not include axial fan or thermostat.

Example of Connection

c. 3-Phase Motor with FB Brake for One Way Rotation (0.1-3.7kW)

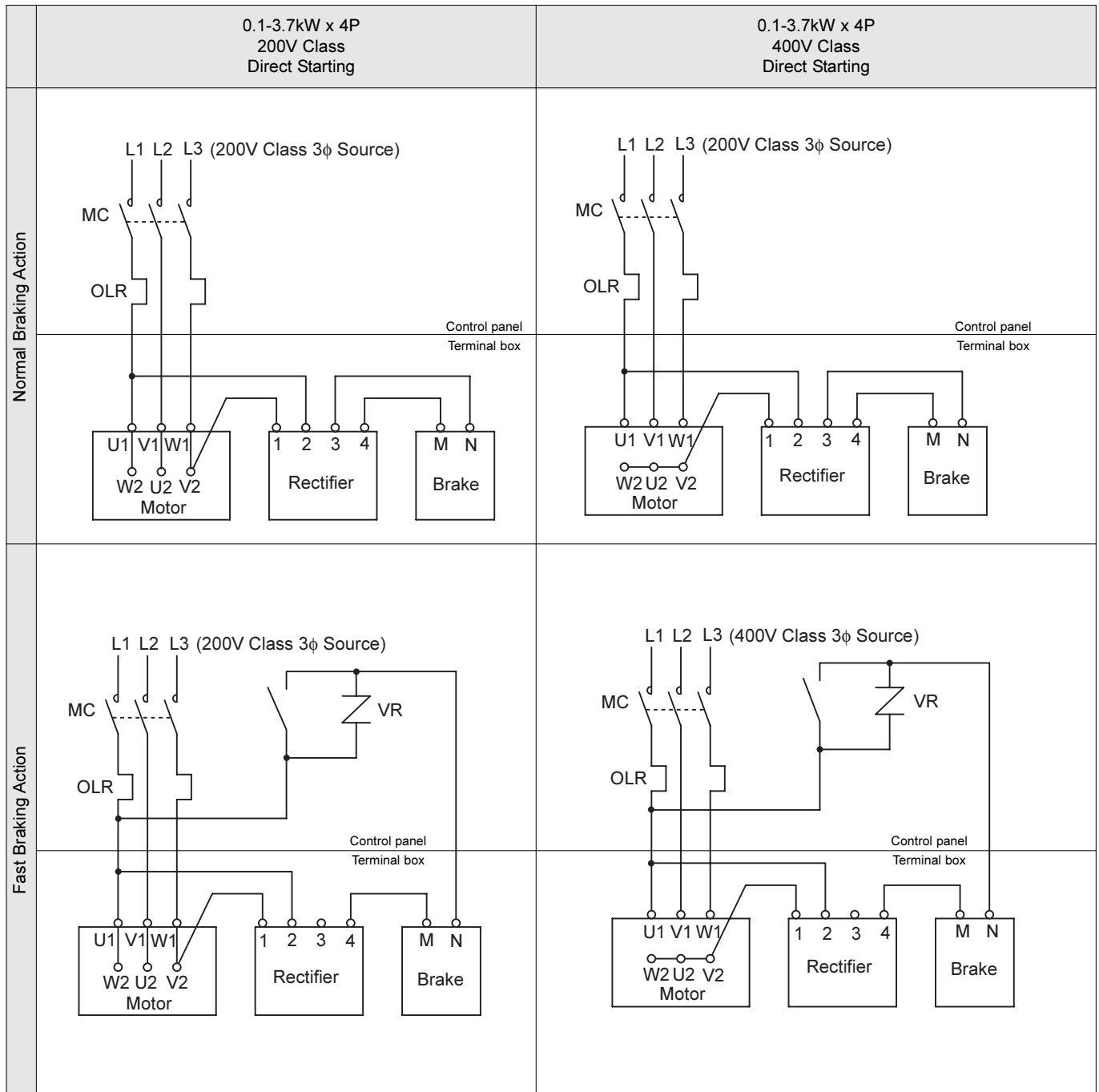

TECHNICAL DATA

Motor

Example of Connection

d. 3-Phase Motor with FB Brake for Operating in Both Directions (0.1-3.7kW)

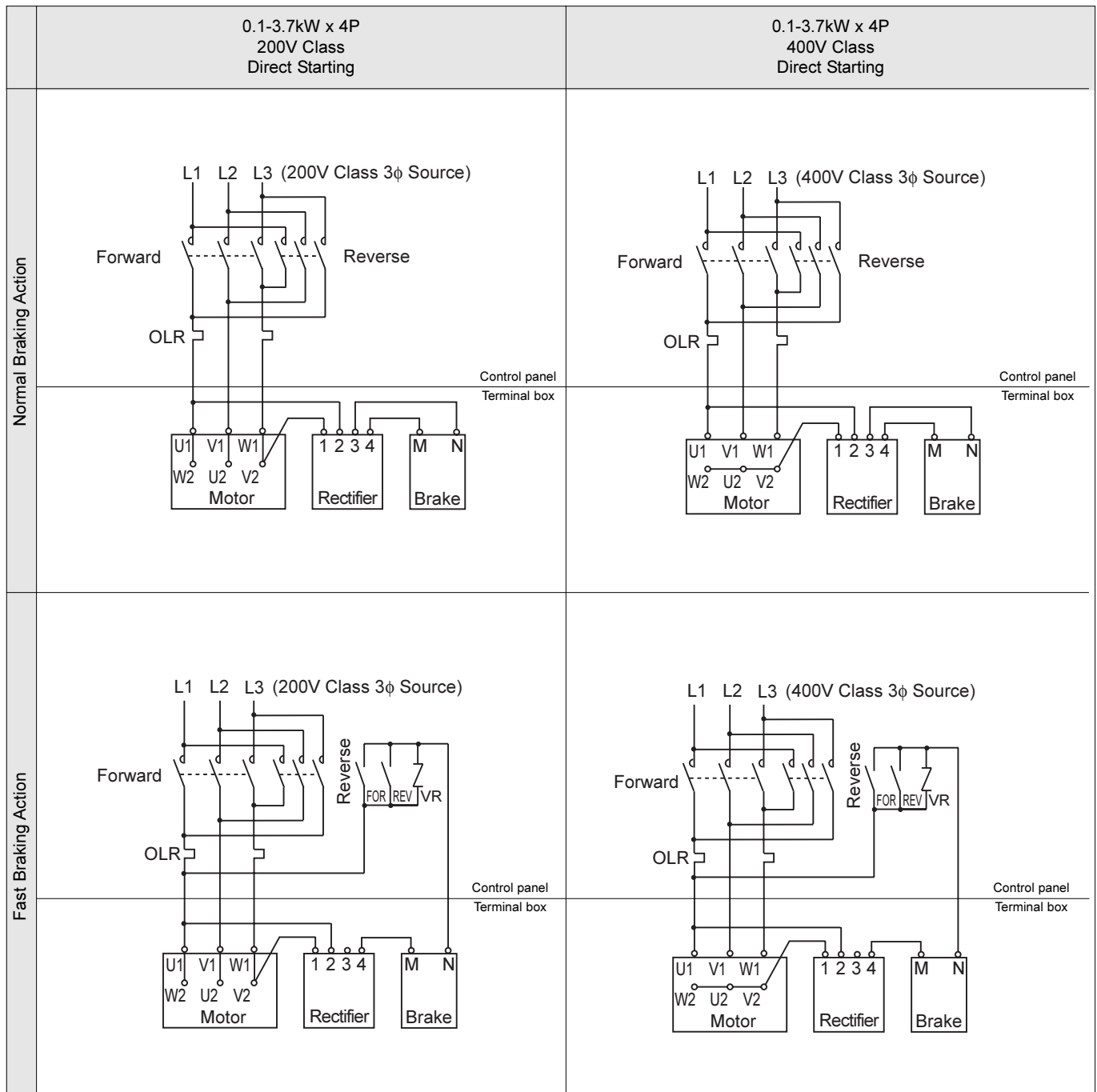

TECHNICAL DATA
Motor

Customer should prepare the following elements on their own
Electromagnetic contactor
OLR: Overload relay (overload protection)
VR: Varistor (protection element)

Brake input power		AC200V~AC230V	AC380V~AC460V
Rated voltage of varistor		AC260V~AC300V	AC510V
Voltage of varistor		AC430V~AC470V	AC820V
Rated Voltage of varistor	FB-01A, 02A, 05A	0.2W and large	0.4W and large
	FB-1B	0.4W and large	0.6W and large
	FB-2B, 3B, 5B	0.6W and large	1.5W and large

Interrupting capacity (direct current coil load) should be at least 5 times of the braking current for contact capacity used in quick braking circuit.

Example of Connection

e. 3-Phase Motor with FB Brake for One Way Rotation (5.5-11kW)

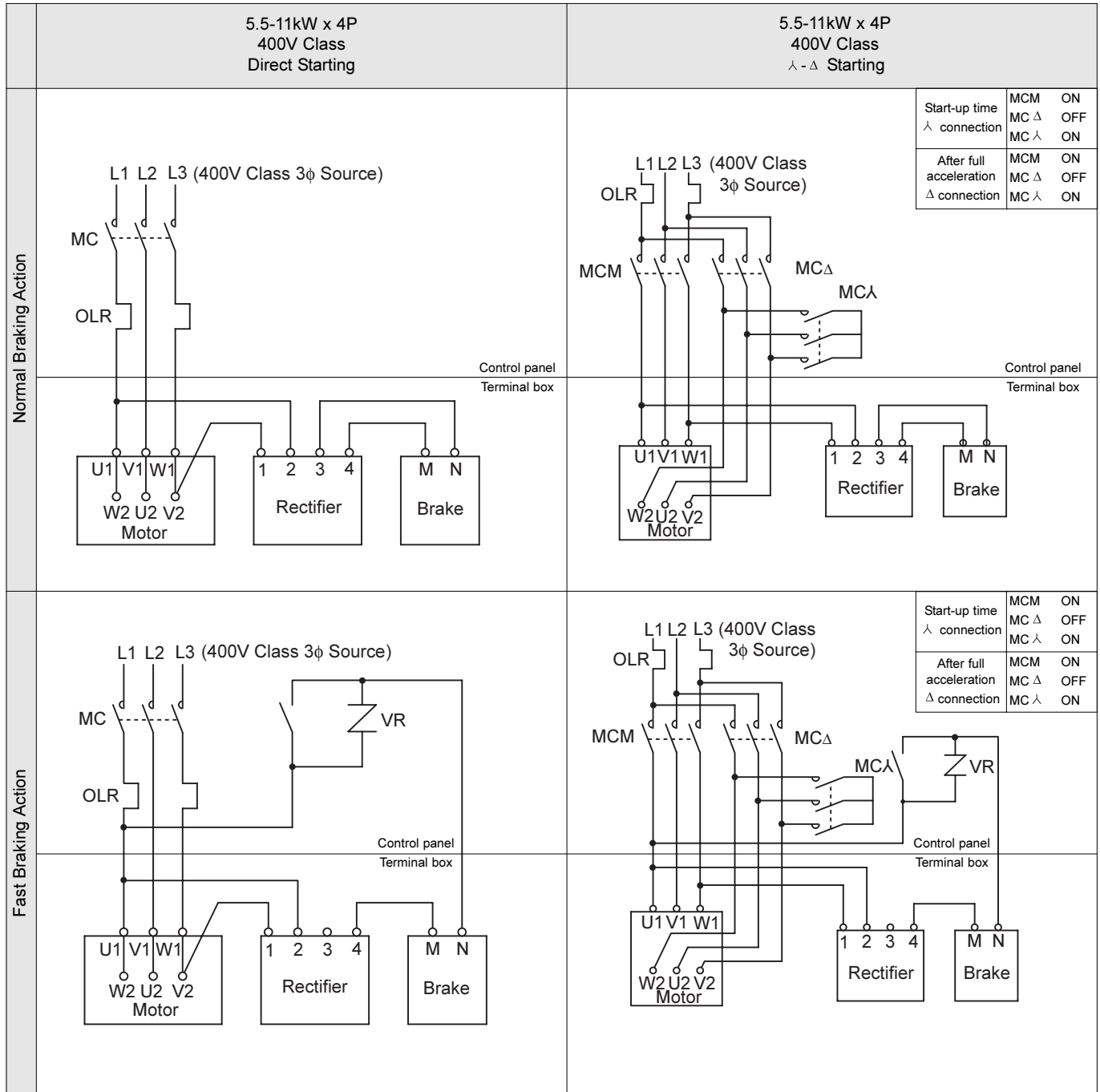

TECHNICAL DATA

Motor

Example of Connection

f. 3-Phase Motor with FB Brake for Operating in Both Directions (5.5-11kW)

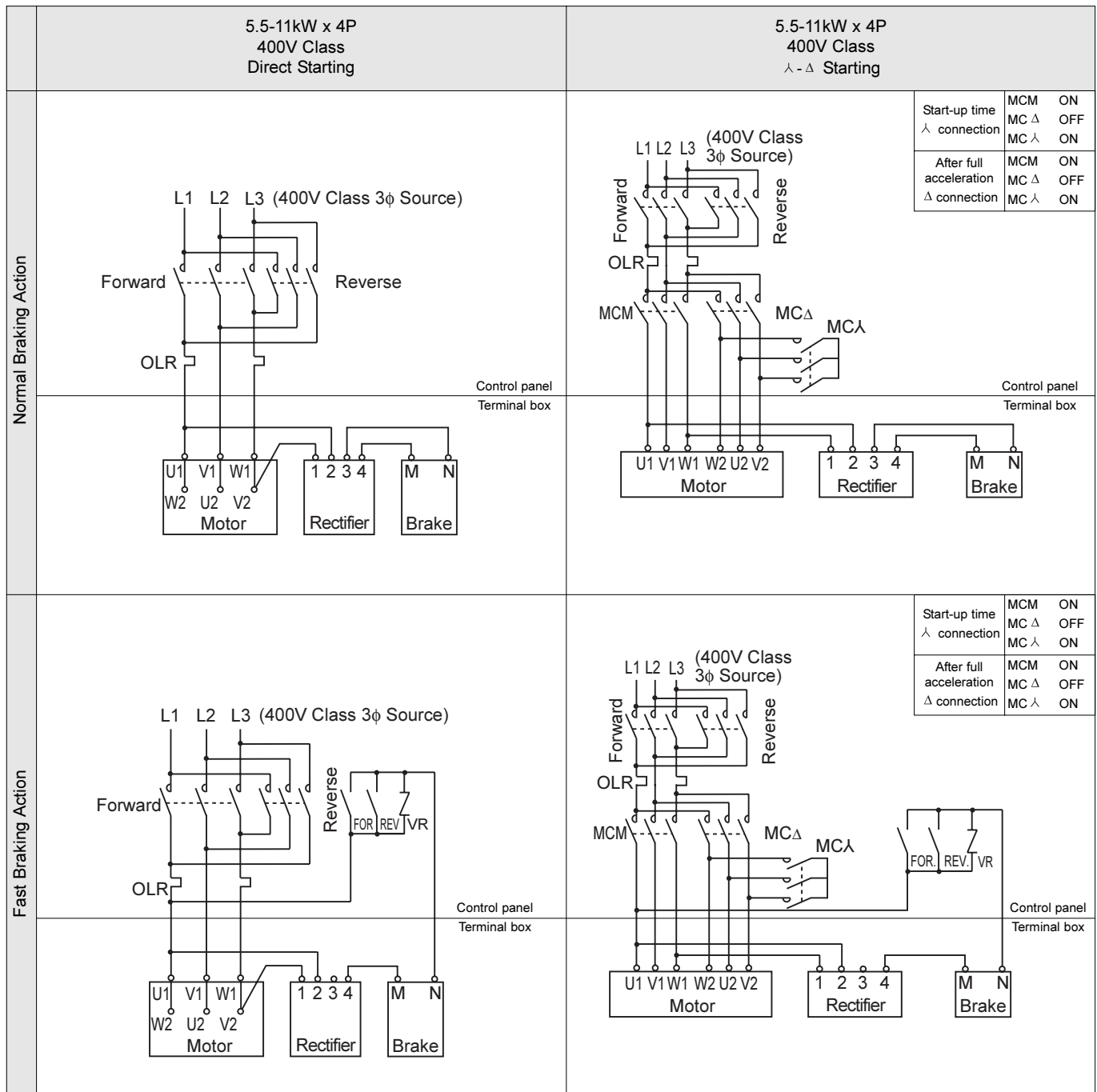

TECHNICAL DATA
Motor

Customer should prepare the following elements on their own
Electromagnetic contactor
OLR: Overload relay (overload protection)
VR: Varistor (protection element)

Brake input power	AC200V~AC230V	AC380V~AC460V	
Rated voltage of varistor	AC260V~AC300V	AC510V	
Voltage of varistor	AC430V~AC470V	AC820V	
Rated Voltage of varistor	FB-8B	0.6W and large	1.5W and large
	FB-10B, 15B	1W and large	1.5W and large

Interrupting capacity (direct current coil load) should be at least 5 times of the braking current for contact capacity used in quick braking circuit.

Example of Connection

g. 3-Phase Motor with CMB Brake for One Way Rotation

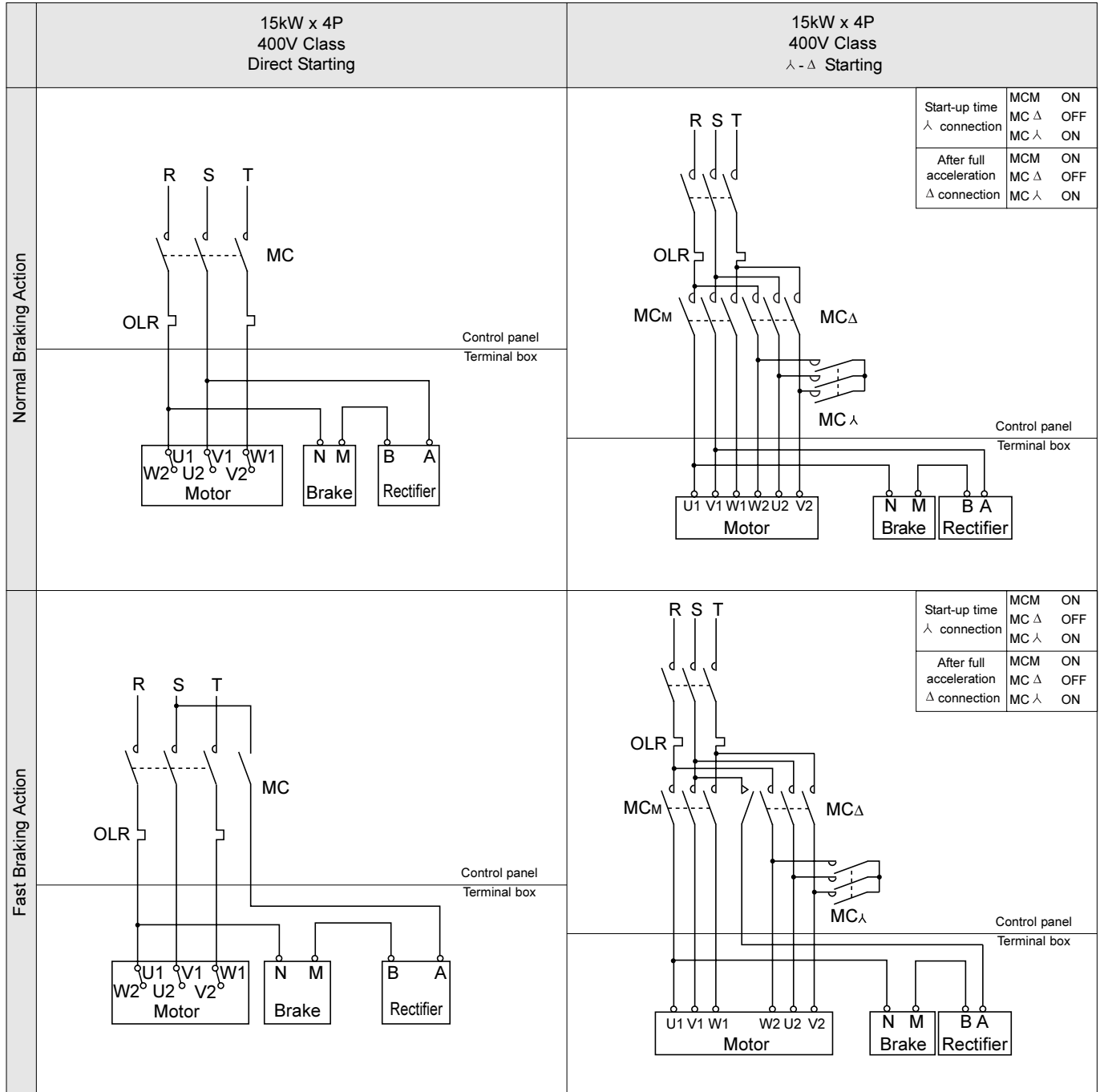

TECHNICAL DATA

Motor

Example of Connection

h. 3-Phase Motor with CMB Brake for Operating in Both Directions

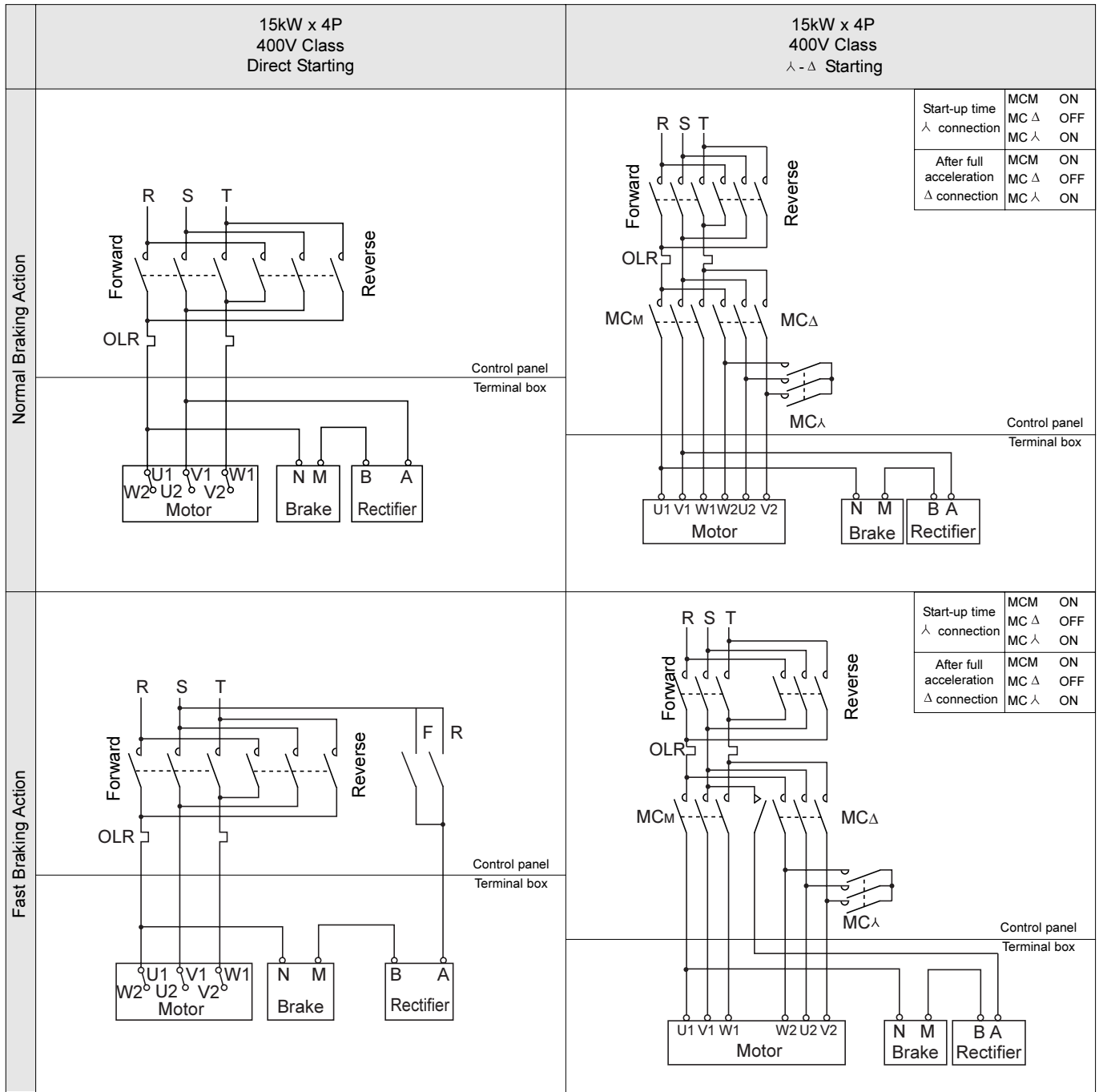

Example of Connection

i. 3-Phase Motor with CMB Brake for One Way Rotation

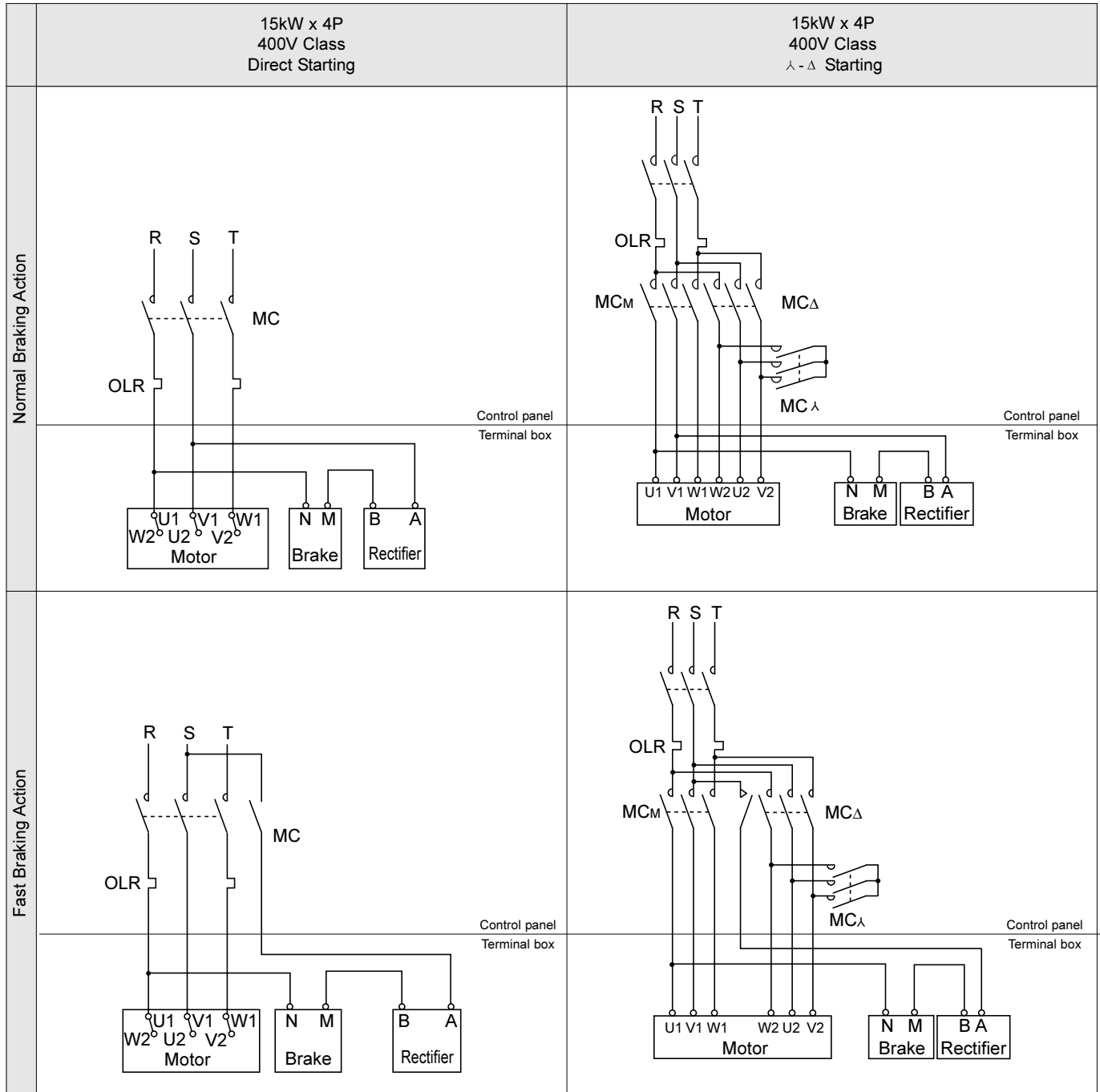

TECHNICAL DATA

Motor

Example of Connection

j. 3-Phase Motor with CMB Brake for Operating in Both Directions

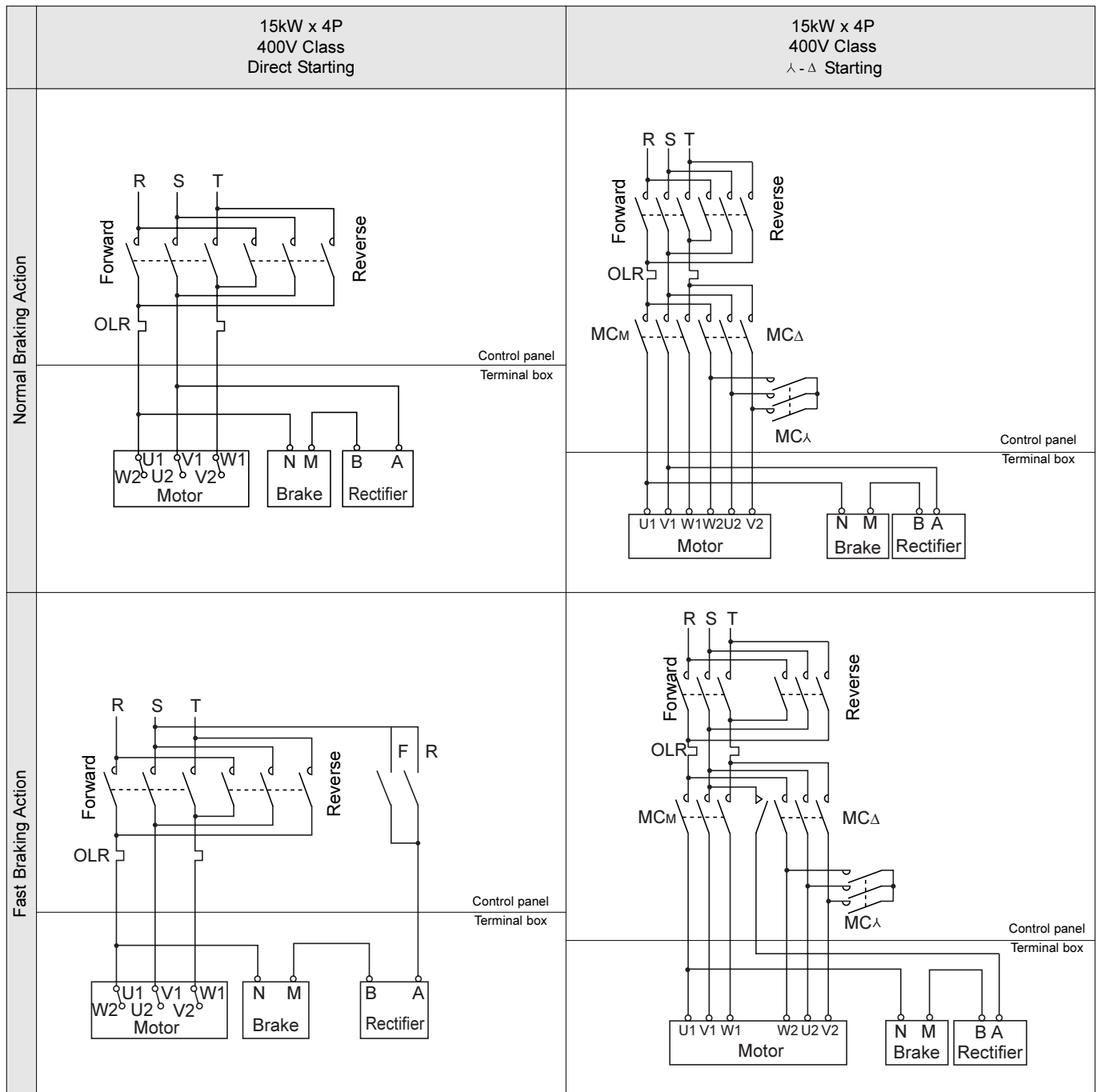

M E M O

A large grid of graph paper for taking notes, consisting of 20 columns and 30 rows of small squares.

Protection and Cooling

No.1 Symbol: Type of protection of humans and solid foreign substances } Classified according to combination (IEC34-1)
 No.2 Symbol: Type of protection against water permeation }

Protection Method of Motors

No.1 Symbol No.1 type	No.2 Symbol No.2 type	0 Non-protected type	2 Drip-proof type	3 Spray-proof type	4 Splash-proof type	5 Water-jet-proof type	6 Sea-wave-proof type	7 Immersion-proof type	8 Submersible type
0 (Non-protected type)		IP00			×	×	×	×	
1 (Semi-protected type)		IP10	IP12S			×	×	×	
2 (Protected type)		IP20	IP22S	IP23S	IP24	×	×	×	
4 (Totally enclosed type)		×			IP44	IP45			
5 (Dust-proof type)		×			IP54	IP55	IP56		

Notes: 1. × denotes difficulty in forming the combination.
 2. Outlined columns shows the range of standard models.
 3. Please consult us if operating conditions include splashed water, or rain.

Class of No.1 Symbol

Type	Symbol	Description
Non-protected	0	Constructed without special protection against human contact and penetration of solid foreign substances.
Semi-protected	1	Constructed to prevent inadvertent contact with rotating and conductive parts inside the machine, by hand or other critical parts of human body. Constructed to prevent penetration of solid foreign substances over 50 mm in diameter.
Protected	2	Constructed to prevent contact with rotating and conductive parts inside the machine, by hand or other critical parts of the human body. Constructed to prevent penetration by solid substances over 12mm in diameter.
Totally enclosed	3	Constructed to prevent contact with the rotating and conductive parts inside the machine, by tools, electric wires, etc., with minimum width and thickness over 1mm. Constructed to prevent penetration of solid foreign substances over 1mm diameter. However, water drainage outlet and exhaust outlet may be of Symbol 2 construction.
Dust-proof type	4	Constructed to prevent contact with rotating and conductive parts inside the machine by any foreign object. Constructed for maximum protection against dust particles penetration, but such penetration will not interfere with normal operation.

Class of No.2 Symbol

Type	Symbol	Description
Non-protected	0	Constructed without special protection against water permeation.
Drip-proof	2	Constructed to prevent harmful effect from dripping water falling from within 15° direction from vertical.
Spray-proof	3	Constructed to prevent harmful effect from dripping water falling from within 60° direction from vertical.
Splash-proof	4	Constructed to prevent harmful effect from dripping water falling from any direction.
Water-jet-proof	5	Constructed to prevent harmful effect from spray from any direction.
Sea-wave-proof	6	Constructed to prevent harmful effect from strong spray from any direction.
Immersion-proof	7	Constructed for submersion into water of prescribed depth and time, without any harmful even when water enter the unit.
Submersible	8	Constructed to assure normal operations under water.

Example: IP - 54

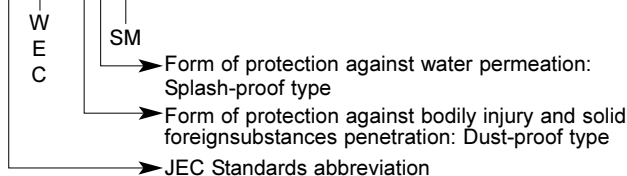

- S: Test of form of protection against water permeation conducted when motor is stopped.
- M: Test of form of protection against water permeation, conducted while motor is operating.
- When S or M is not indicated: Conduct test when motor is at stop and during operation.
- W: Outdoor type (Only Non - protected)
- E: Explosion-proof type
- C: Form of protection against other harmful atmosphere.

Cooling

Enclosure Construction	IEC Standards
Totally enclosed, non-ventilated (TENV)	IC410
Totally enclosed, fan-cooled (TEFC)	IC411
Totally enclosed, Air over (TEAO)	IC416

TECHNICAL DATA
Motor

International Standards and Compliance of Sumitomo Products

UL Standards (Underwriters Laboratories)

UL Standards are established by Underwriters Laboratories Inc. (UL), an independent, not-for-profit product-safety testing and certification organization in the USA. It conducts series of scientific study, research, and testing to prevent harmful effect to human life, fire, and disaster. Although there is no regulation by the Federal Government for manufacturers' compliance, some state and cities mandate them. Using Sumitomo product with UL Standard Certification will represent your reliability, which is highly appreciated in the USA.

Motor	Non-explosion proof single-phase induction motor *1	Non-explosion proof 3-phase induction motor	3-phase induction motor with brake
Power	1/8~1HP × 4P	1/8~60HP × P	1/8~8HP × 4P
Voltage	115V, 230V	208V, 230V, 460V, 575V	
Frequency	60Hz		
Thermal class	Class A	*3 Class A (Class B, Class F)	Class F
Ambient conditions	Indoor type *2		

*1 Contact us for manufacturing single-phase motor or motor with brake.

*2 Outdoor types are unavailable.

*3 Contact us for manufacturing insulation Type B and F.

Differences from Sumitomo standard models

- Terminal symbol: 1, 2, 3
- Name plate with UL mark and measurement expressed by units HP
- Opposite rotating direction from the Japanese domestic products
- Copper terminal box
- UL standard motor coil and brake coil

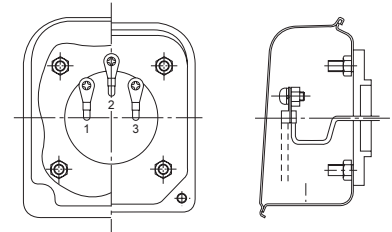

3-Phase indoor terminal box



UL Mark

SM-CYCLO® 3 PHASE INDUCTION MOTOR		UL
HP	P	TYPE
VOLTS	FRAME	
Hz	INS. CLASS	
AMP	TIME RATING	
RPM	SERVICE FACTOR	
CODE	MAX AMB °C	
SER. NO.		

SUMITOMO MACHINERY CORP. OF AMERICA
CHESAPEAKE, VIRGINIA

UL Nameplate

Remarks

- Motors must be manufactured, modified, and repaired at certified factories.
- Certified motor for inverter (AF Motor) may be manufactured for range 1/8~11HP.

CSA Standards (Canadian Standards Association)

CSA Standards are established by the semiprivate Canadian Standards Association, a not-for-profit membership-based association. Most of the Canadian states requires this CSA certification for its domestically sold electric related products. Some American states evaluate CSA Standards comparable to UL Standards.

Motor	1-phase induction motor *1	3-phase induction motor	3-phase induction motor with brake	High efficiency 3-phase induction motor *1	High efficiency 3-phase induction motor with brake *1
Power	1/8~1HP × 4P	1/8~60HP × 4P	1/8~30HP × 4P	1.5~50HP × 4P	1.5~30HP × 4P
Voltage	115V, 230V	208V, 230V, 460V, 575V		230V, 460V, 575V	
Frequency	60Hz				
Thermal class	Class B (and Class F)				
Ambient conditions	Indoor type *2				

*1 Contact us for manufacturing of single-phase or high-efficiency motor with brake.

*2 Outdoor types are not available.

Differences from Sumitomo standard models

- Terminal symbol: 1, 2, 3 (with Brake type, T1, T2, T3)
- The frame size of a high-efficiency motors are different from standard types.
- Name plate with CSA mark and measurement in HP
- Opposite rotating direction
- Copper terminal box
- CSA standard motor coil

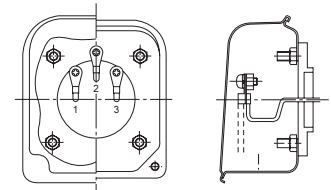

3-Phase indoor terminal box



CSA Mark

SM-CYCLO™ 3 PHASE INDUCTION MOTOR		CSA
HP	P	TYPE
VOLTS	FRAME	
Hz	M / B INS. CLASS /	
M.AMP	TIME RATING	
RPM	SERVICE FACTOR	
B.AMP	MAX AMB °C	
B.TORQUE	FT-LB	ENCLOSURE TE
MANUF. No.		

SM CYCLO OF CANADA, LTD.
TORONTO, MONTREAL, VANCOUVER

CSA Nameplate

Remarks

- CSA certified motor is necessary for export to Canada. In addition, high-efficiency motor is necessary for 1 HP and above.
 - Motors must be manufactured, modified, and repaired at certified factories.
 - Because CSA does not certify motors for inverters, our AF Motors is not CSA certified and does not come with the CSA
 - Mark although it complies with the CSA standard.
- NRCan established the energy efficiency act (EEACT) in 1992 and the energy efficiency regulations (EER) in 1995. Additional regulations were applied to gearmotors imported on November 27, 1999 and later. Gearmotor import which do not meet the efficiency standards are now banned under this law.(Subject capacity: 1~200HP, Subject frame: IEC frame size 90 and above, Subject voltage: 600V and below, constant speed motor)

International Standards and Compliance of Sumitomo Products

NEMA Standards (National Electrical Manufacturers Association)

NEMA Standards include numerous standards for electric products established by the National Electrical Manufacturers Association (NEMA) to eliminate misunderstandings between manufacturer and purchaser.

Differences from Sumitomo standard models

- Terminal symbol: 1, 2, 3
- Name plate marked with NEMA DESIGN and measurement in HP
- Opposite rotating direction from the Japanese domestic products
- Copper terminal box
- NEMA standard motor coil

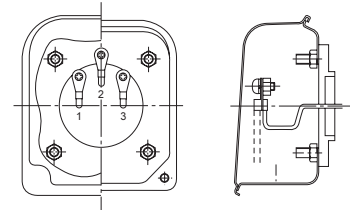

3-Phase indoor terminal box

Remarks

- No approval is required to state NEMA compliance
- NEMA is also applicable for inverter motor (AF motor), but limited to terminal symbols, measurement in HP, rotating direction and terminal box.

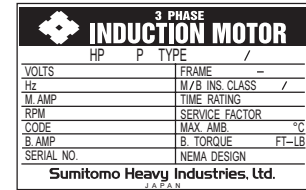

NEMA Nameplate

Other Standards

- : Sumitomo standards
- △: Manufactured specially on customer's request

Application of International Standards (Example)

Country/Standards	Japan · JIS JEM JEC	International · IEC	UK · BS
Standard output	○	○	△: 4kW and below ○: 5.5kW and above
Applicable output frame size	○	-	△
Motor mounting dimension of each frame size	○ Note	○ Note	○ Note
Shaft end dimension	○ Note	○ Note	△ Note
Dimension tolerance of shaft end key and keyway	○ Note	○ Note	△ Note
Thermal class	○	○	○
Lead wire code	○	○	○
Standard rotation direction	○	△	△
Description on nameplate	○	△	△
Characteristic testing method	○	○	△
Standard voltage	200V·220V 400V·440V	△	415V
Standard frequency	50Hz, 60Hz	50Hz, 60Hz	50Hz

IEC- International Electrotechnical Commission.
BS- British Standards.

Note: CYCLO flange dimension is the standard. Consult us for flange dimension for your required compliance standards.

Major Japanese Standards

- | | |
|--|--|
| <p>(1) General rotating electrical machines
JIS C 4004 (1992): General rules for rotating electrical machines
JEC-200 (1993): Rotating machinery in general
JEM 1188 (1969): Rated output values of electric motors</p> <p>(2) General 3-phase induction motors
JIS C 4210 (1983): Low-voltage 3-phase squirrel cage induction motors for general purpose
JIS C4212 (2000): High efficiency low-voltage 3-phase squirrel cage induction motors.
JEC-37 (1979): Induction machines</p> <p>(3) Methods of testing and calculating characteristics
JEC-37 (1979): Induction machines
JIS C 4207 (1995): Calculating method of 3-phase induction motors characteristics</p> <p>(4) Dimensions
JEM 1400 (1991): Dimension of low-voltage 3-phase squirrel cage induction motors for general purpose
JEM 1401 (1991): Dimensions of flange-mounted low-voltage 3-phase squirrel cage induction motors for general purposes</p> <p>(5) Explosion-proof construction
JIS C 0903 (1983): Electrical apparatus for explosive atmospheres in general industries</p> | <p>JIS C 0904 (1983): Test methods on electrical apparatus for explosive gas atmospheres in general industries</p> <p>JIS C 0905 (1983): Supplementary requirements for construction of electrical apparatus for explosive atmosphere in general industries</p> <p>Recommended practices for explosion-protected electrical installations in general industries (1979)
Rules for authorization of explosion-proof construction of electrical machine tools (1981)</p> <p>(6) Others
JIS C 4003 (1977): Classification of materials for insulation of electrical machinery and apparatus
JEC-147 (1960): Classification of materials for insulation of electrical machinery and apparatus
JEM 1313 (1983): Noise levels for low-voltage 3-phase squirrel-cage induction motors for general purpose</p> <p>Abbreviations: JEC Japanese Electrotechnical Committee Standards
JIS Japanese Industrial Standard
JEM Japan Electrical Manufacturers' Association</p> |
|--|--|

TECHNICAL DATA

Motor

International Standards and Compliance of Sumitomo Products

CCC Standards (China Compulsory Certification)

China had implemented the China Compulsory Certification (CCC) system since May 1, 2002 as becoming the full member of World Trade Organization (WTO). They have moved on to compulsory licensing on August 1, 2003. Motor capacity 1.1kW and below are subject to this certification, and requires CCC Mark for sales in China. Below table is our motor with CCC.

Motor	Single Phase Motor		Three Phase Motor		AF Motor	AF Motor (Foot Mount)
Capacity	15~90W	0.1~0.75kW	40~90W	0.1~1.1kW	0.1~0.75kW	0.4~0.75kW
Voltage	220V		380V			
Frequency	50Hz		50Hz			
Thermal class	Class E	Class B	Class E	Class F		
Usage	Indoor (IP44), Outdoor (IP55)		Indoor (IP44), Outdoor (IP55)			

AF motor: 3 Phase Motor for inverter

Difference with standard items

- CCC Mark as in the right is applied on the nameplate.
- Aluminum terminal box is the standard for three phase motor (except indoor specification for 40~90W).
- Terminal block type (6 terminals, European system) is the standard for three phase motor (for 0.1kW or more).
- Rotational direction is the opposite from Japanese domestic specification (in CCW direction looking from the anti-load side).
- CCC correspondence motor coil is used.



China Compulsory Certificate

Remarks

- CCC Mark is necessary when exporting small size motor (or gearmotor) units of 1.1kW or below to China.
- Subject service products and spare parts without certification may be permitted for import to China by applying for exemption. Consult us for any clarification.

EC Directives and CE Marking

EC Directives are established to for free distribution of products across the borders within the European Union (EU). CE Mark applied on the product indicates their compliance to EC Directives..

Relevant EC Directives and Implementation Timing

The following three directives apply to ordinary machine products.

EC directives	Subjects	Directive details
Machinery Directive	Aggregates of parts, which are movable (Industrial machines, primarily)	Essential matters related to safety of machines are stipulated. Machines that are electrically dangerous shall fulfill the requirements for low voltage.
Low Voltage Directive	Products driven by power of 50-1,000 VAC or 75-15,000 VDC	Products not conforming to standards cannot be put on the market.
Electromagnetic Compatibility Directive	All types of products that may cause jamming (electromagnetic radiation) or have their functions impeded by nearby radio waves	EMI: Not to cause external electromagnetic interference EMS: To withstand external electromagnetic interference

Transition and Time Limits of CE Marking Implementation for Major Directives

EC Directive	Year	1990	1991	1992	1993	1994	1995	1996	1997	1998	1999	2000	2001	2002	2003
Machinery Directive 89/392/EEC Original 91/368/EEC Revision I 93/44/EEC Revision II					1/1		1/1								
				Transition		Enforcement									
EMC Directives 89/336/EEC Original 92/31/EEC Revision I				1/1				1/1							
				Transition			Enforcement								
Low Voltage Directive 73/23/EEC Original 93/68/EEC Revision I							1/1		1/1						
							Transition		Enforcement						

TECHNICAL DATA

Motor

Conformity to EC Directive and CE Mark of Our Products

Our induction motor conforms to the Machinery Directive (issued January 1995) and Low Voltage Directive (issued January 1996) of the EC Directives.

EMC Directive (issued January 1996) does not contain statements for induction motors.

CE marking logo shown on nameplates



EC Directives and CE Marking

Standard Specifications of CE Marking Motors

- Input power: 0.1kW~4kW : 230/400V 50Hz Dual voltage direct starting
5.5kW or more : 400V 50Hz Δ - Δ Start
- Thermal class: 0.1kW~0.4kW : Class E
0.75kW or more : Class B
- Rated time: Continuous
- Characteristics: IEC34-1
- Protection: IP54 (without brake), IP44 (with brake)
- Terminal box: (Material) 5.5kw or less: Aluminum (M25 bolts (P1.5) × 2pcs)
7.5kw or more: Cast iron (M32 bolts (P1.5) × 2pcs)
(Specification) Terminal plate (six terminals European style)
With grounding terminal
Conduit tube of M thread
- Shaft rotating direction: Rotating direction is reverse to Japanese standard direction.
- Insulation: Distances between insulated surfaces and spaces conforms to IEC Standards.
- External dimensions: Same as standard except for the terminal box
- TÜV Test Report: Representative model 0.75kW × 4p, 230V/400V is TÜV certified (Oct 1996)
Our CE marking motors are manufactured conforming to TÜV.
- Declaration of Conformity: "Declaration of Conformity" document is necessary for CE marking is available.

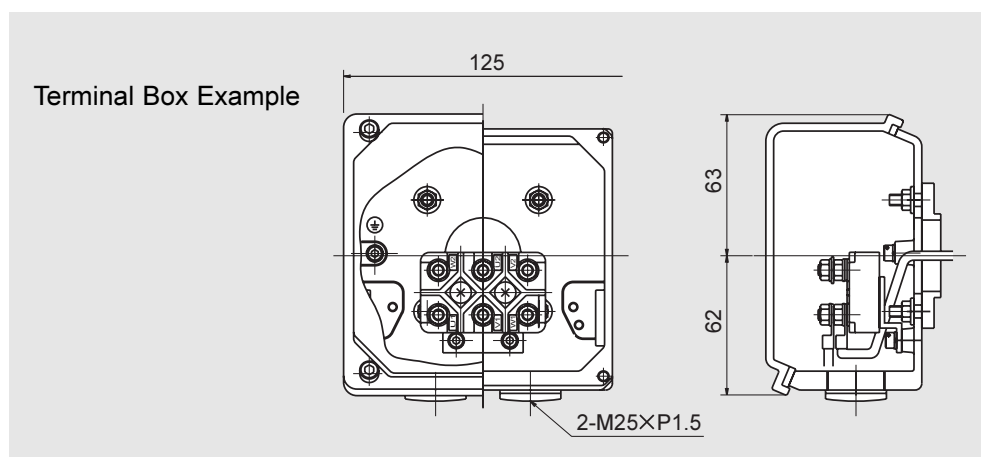

TECHNICAL DATA
Motor

Manufacturing range of CE Marking Motors

3-phase induction motor

Input power symbol	230/400V dual voltage															400V		
	01	012	018	02	03	04	05	08	1	1H	2	3	4	5	6	8	10	15
KW × 4P	(0.1)	0.12	0.18	(0.2)	0.25	0.37	(0.4)	0.55	0.75	1.1	1.5	2.2	3	(3.7)	4	5.5	7.5	11
Frame size	F63S		F63M			F71M		F80S	F80M	F90S	F90L	F100L	F112S	F112M		F132S	F132M	F160M

- kW without brackets in the above table indicate standard capacity for Europe. kW within the brackets indicate capacity in Japan and some other countries.
- Standard European kW motors are recommended. Motors of kW's within brackets are also available.
- 3-phase 200V/50Hz, 200V/60Hz, 220V/60Hz
- 3-phase 400V/50Hz, 400V/60Hz, 440V/60Hz
- 3-phase 380V/50Hz, 415V/50Hz
- Contact us for motors with kW and voltage not shown in the above table.
- Consult us for M bolt (Metric bolt) for conduit tube.

International Power Source Voltage and Conditions

Country / Area		Frequency	Voltage	
Japan		50Hz / 60Hz	Single phase 100V / 200V, 3-phase 200V / 400V	
North America	America	60Hz	Single phase 115V / 230V, 3-phase 230V	
	Canada	60Hz	Single phase 120V / 347V, 3-phase 230V, 460V, 575V	
Asia	Korea	60Hz	Single phase 110V / 220V, 3-phase 220V / 380V	
	Taiwan	60Hz	Single phase 110V / 220V, 3-phase 200V / 220V / 380V	
	Hong Kong	50Hz	Single phase 200V / 220V, 3-phase 346V / 380V	
	China	50Hz	Single phase 220V, 3-phase 220V / 380V	
	Philippines	60Hz	Single phase 220V, 3-phase 380V	
	Thailand	50Hz	Single phase 220V, 3-phase 220V / 380V	
	Singapore	50Hz	Single phase 230V, 3-phase 415V	
	Malaysia	50Hz	Single phase 240V, 3-phase 415V	
	Indonesia	50Hz	Single phase 220V, 3-phase 380V	
	India	50Hz	Single phase 240V, 3-phase 240V / 415V	
	Bangladesh	50Hz	Single phase 230V, 3-phase 400V	
	Oceania	Australia	50Hz	Single phase 240V, 3-phase 415V
		Guam	60Hz	Single phase 120V, 3-phase 240V / 480V
New Zealand		50Hz	Single phase 230V, 3-phase 230V / 415V	
Europe	Austria	50Hz	Single phase 230V, 3-phase 400V	
	Belgium	50Hz	Single phase 230V, 3-phase 400V	
	Bulgaria	50Hz	Single phase 220V, 3-phase 380V	
	Denmark	50Hz	Single phase 230V, 3-phase 400V	
	Finland	50Hz	Single phase 230V, 3-phase 400V	
	France	50Hz	Single phase 230V, 3-phase 400V	
	Germany	50Hz	Single phase 230V, 3-phase 400V	
	Greece	50Hz	Single phase 230V, 3-phase 400V	
	Hungary	50Hz	Single phase 220V, 3-phase 380V	
	Italy	50Hz	Single phase 220V, 3-phase 380V	
	Luxembourg	50Hz	Single phase 230V, 3-phase 400V	
	Netherlands	50Hz	Single phase 230V, 3-phase 400V	
	Norway	50Hz	Single phase 220V / 230V, 3-phase 380V	
	Poland	50Hz	Single phase 220V, 3-phase 380V	
	Portugal	50Hz	Single phase 230V, 3-phase 400V / 480V	
	Romania	50Hz	Single phase 220V, 3-phase 380V	
	Spain	50Hz	Single phase 127V / 220V, 3-phase 220V / 380V	
	Sweden	50Hz	Single phase 230V / 400V, 3-phase 400V / 690V	
	Switzerland	50Hz	Single phase 230V, 3-phase 400V	
	United Kingdom	50Hz	Single phase 230V, 3-phase 400V	

*Voltage may differ from above in certain region or city, even in the same country.

*Single phase 120V indication is typical for USA and Canada, although their standard voltage is 115V.

F TECHNICAL DATA

3. Common

TECHNICAL
DATA

Common

Paint and Rustproof Coating

1. Coating Specifications

Treatment	Kind of painting			Painting specifications			Applied paint		Weather resistance	Submersible	Oil-proof	Acid resistance	Alkal resistance	Heat resistance (°C)	Application
	Classification	Paint of finish coat	Additional leadtime (days)	Type	Layers (µm)	Quality	Brand								
Cast Iron: Near White blast cleaning	Standard	-	0	Under coating	1	Modified alkyd resin	UNIGROUND PTC PRIMER							100	Standard under coat
		Acrylic modified phthalic	0	Finish coating	1 (15~30)	Acrylic modified alkyd resin	NEORON #2000		○	×	△	⊕	⊖	100	Standard under coat
	Standard export painting	Acrylic modified phthalic	2	Under coating	2 (30~60)	Modified alkyd resin	UNIGROUND PTC PRIMER							100	Models for export
				Finish coating	1 (15~30)	Acrylic modified alkyd resin	NEORON #2000		○	×	△	⊕	⊖		
	Special painting (including rust-proof and heat resisting painting) one layer of Uniground PTC Primer as the first primer	Modified epoxy	3	Under coating	1 (20~40)	Vinyl modified alkyd resin	NEO-GOSE #500 Red lead primer		○	△	○	⊕	⊖	100	Moderate corrosive atmosphere, sea side, outdoor humid atmosphere, chemical plant area, etc.
				Finish coating	2 (30~60)	Acrylic modified alkyd resin	Acron #300								
		Long oil phthalic (synthetic resin type)	7	Under coating	2 (40~70)	Lead rust preventive paint	SD MARINE PRIMER (rust)		○	×	×	⊕	⊖	100	Ocean-going vessel & boat, bridge, sea side, outdoor humid atmosphere, etc.
				Finish coating	2 (30~60)	Synthetic resin paint	PENFORTE #600								
		Chloride rubber	10	Under coating	2 (40~70)	Lead rust preventive paint	SD MARINE PRIMER (rust)		○	△	△	○	○	80	Ocean-going vessel & boat, bridge, sea side, outdoor humid atmosphere, etc.
				Second coating	2 (30~60)	Phenol M.I.O paint	SHINTO MIO								
	Finish coating			2 (40~70)	Chloride rubber paint	RUBBER #100									
	Phenol	7	Under coating	2 (40~70)	Lead rust preventive paint	SD MARINE PRIMER (rust)		○	×	△	○	⊕	100	In-and-out door of acid treating plant or chemical plant, etc.	
Finish coating			2 (30~60)	Phenol resin enamel	NEW AKNON										
Heat-proof silver	7	Under coating	1 (20~40)	Lead rust preventive paint	SD MARINE PRIMER (rust)		○	×	×	×	×	120	Heating furnace (120°C), etc.		
		Finish coating	1 (15~30)	Aluminum paint	SILVER TOP (heat resisting)										
Steel plate: Power tool cleaning	Epoxy	10	Under coating	1 (50~60)	Special permeability epoxy aluminum paint	CARBOMASTIC #15		⊙	○	○	○	○	150	Chemical contact area, chemical plant, anticorrosion plant, etc.	
			Finish coating	3 (30~90)	Polyamide epoxy	NEO-GOSE #200									
	Epoxy	10	Under coating	1 (50~60)	Special permeability epoxy aluminum paint	CARBOMASTIC #15		⊙	○	○	○	○	150	Nuclear power plant, etc.	
			Finish coating	3 (30~90)	Polyamide epoxy	NEO-GOSE #2300CW									
	Polyurethane	10	Under coating	1 (50~60)	Special permeability epoxy aluminum paint	CARBOMASTIC #15		⊙	○	○	○	○	150	Nuclear power plant, etc.	
			Finish coating	3 (45~90)	Polyisocyanate urethane resin paint	NY POLIN K finish coat									
Extra rustpreventive painting (sand blast undercoating)	Thick film epoxy	12		5 (250~350)	Thick film type modified epoxy resin paint	NEO-GOSE #2300 NTHB		⊙	⊙	○	○	○	100	Submersible equipment, marine structure, etc.	

TECHNICAL DATA
Common

- Note:
- "Additional leadtime" refers to the number of days required for special coating in addition to standard painting.
 - Standard coating is 6.5PB 3.6/8.2. Coating specification may differ for special coating color.
 - Paint specified above is subject to replacement by comparable product.
 - "**" indicates coating which may fade with sunlight.
 - Consult us when ambient temperature exceeds heat resistance temperature indicated above.
(Heat resistance temperature above is only for the paint, not for the CYCLO® DRIVE.)
 - Consult us when ambient temperature fluctuates between low and room temperature in short time period.
 - Thick film epoxy coating has limited color selections. Consult us for coating other than N1.0 or 10GY6/2.
(Our standard coating 6.5PB3.6/8.2 may not be applied.)

○ ○ ○ ⊕ ⊖: Appropriate
△: Caution necessary for selection
×: Inappropriate

Paint and Rustproof Coating

2. Surface Conditioning

Treatment	Surface condition after treatment	Methods	Standards	
			SSPC	SIS
Class 1 Near white blast cleaning	Surface completely free of mill scales, rust, corrosives, dirt, and other foreign substances. Embedded residues (mill scales, rust, slight smears, or discoloration of oxide substances) are acceptable. However, minimum 95% of the surface area should be visibly clean of any residues. Remaining surface may contain slight discolorations, such as stains.	<input type="radio"/> Near White <input type="radio"/> Blast cleaning <input type="radio"/> Shot blast <input type="radio"/> Sand blast, etc.	SP-10	Sa-2 1/2
Class 2 Power tool cleaning	Surface free of loose mill scales, rust, corrosives, dirt, and other foreign substances. Embedded residues (mill scales, rust, slight smears or discoloration of oxide substances) are acceptable. However, minimum 2/3 of the surface area should be visibly clean of any residues. Remaining surface may contain slight discolorations, such as stains, and residual rust, and coating peelings in pores, for surface with porous corrosion.	<input type="radio"/> Commercial Blast cleaning <input type="radio"/> Power Tool Cleaning <input type="radio"/> Disk sander <input type="radio"/> Wire wheel <input type="radio"/> Grinder, etc.	SP-6 (SP-3)	Sa-2 (St-3)
Class 3 Hand tool cleaning	Surface free of loose scales, rust, coating, oil & grease, dirt, and other foreign substances, with slight metallic luster. The surface should be cleaned with wire brush, scraper, etc.	<input type="radio"/> Hard Tool Cleaning <input type="radio"/> Wire brush <input type="radio"/> Scraper, etc.	SP-2	St-2

(U.S.A. Steel Structural Painting Councils) (SWEEDEN, SVENSK Standard, S.I.S. 055900)

Rustproof Treatment Standards

Our complete products are shipped with following rust proofing treatment.

1. Standard Rustproof Specification

(1) External Rustproof

Our assembled products are shipped with rust proofing oil applied. Check rustproof condition six months after shipment. Reapply rustproof treatment if necessary.

(2) Internal Rustproof

Lubrication	Grease lubricated models	Oil lubrication models
Rustproof period	1 year	6 months
Storage condition	Storage inside general shop or warehouse, with relatively low humidity, dust, extreme temperature fluctuation, corrosive gas, or such.	

2. Rustproof Specification for Export

Consult us for when the item is exported or if more treatment is necessary than standard rustproof treatment. Export rustproof treatment is available.1.

Drive System Formulas Reference Materials

1. Speed N (r/min) and Velocity (m/s)

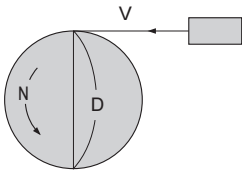

$$V = \pi \cdot D \cdot \frac{N}{60} \text{ (m/s)}$$

π : Circular constant (≈ 3.14)
D: Wheel diameter

2. Torque T (N·m, kgf·m)

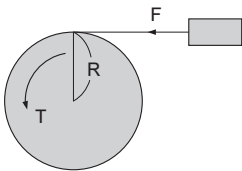

[SI Units]
 $T = F \cdot R \text{ (N·m)}$

F: Load (N)
R: Wheel radius (m)

[Gravitational Units]
 $T = F \cdot R \text{ (kgf·m)}$

F: Load (kgf)
R: Wheel radius (m)

3. Power P (kW)



[SI Units]

$$P = \frac{F \cdot V}{1000}$$

F: Load (N)
V: Velocity (m/s)

[Gravitational Units]

$$T = \frac{F \cdot V}{102}$$

F: Load (kgf)
V: Velocity (m/s)

4. Power P (kW), Torque T (N·m, kgf·m), Speed N (r/min)

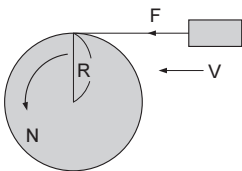

[SI Units]

$$P = \frac{N \cdot T}{9550} \text{ (kW)}$$

$$T = \frac{9550 \cdot P}{N} \text{ (N·m)}$$

$$P = \frac{F \cdot V}{1000} \text{ (kW)}$$

$$V = \pi \cdot 2 \cdot R \cdot \frac{N}{60} \text{ (m/s)}$$

F: Load (N)

$$\therefore P = \frac{F \cdot \pi \cdot 2 \cdot R \cdot \frac{N}{60}}{1000} = \frac{2 \cdot \pi}{1000 \cdot 60} \cdot N \cdot F \cdot R \text{ (kW)}$$

$$T = F \cdot R$$

$$\therefore P = \frac{2 \cdot \pi}{1000 \cdot 60} \cdot N \cdot T = \frac{N \cdot T}{9550} \text{ (kW)}$$

[Gravitational Units]

$$P = \frac{N \cdot T}{975} \text{ (kW)}$$

$$T = \frac{975 \cdot P}{N} \text{ (kgf·m)}$$

$$P = \frac{F \cdot V}{102} \text{ (kW)}$$

$$V = \pi \cdot 2 \cdot R \cdot \frac{N}{60} \text{ (m/s)}$$

F: Load (kgf)

$$\therefore P = \frac{F \cdot \pi \cdot 2 \cdot R \cdot \frac{N}{60}}{102} = \frac{2 \cdot \pi}{102 \cdot 60} \cdot N \cdot F \cdot R \text{ (kW)}$$

$$T = F \cdot R$$

$$\therefore P = \frac{2 \cdot \pi}{102 \cdot 60} \cdot N \cdot T = \frac{N \cdot T}{975} \text{ (kW)}$$

Drive System Formulas Reference Materials

5. Acceleration Force F_A (N, kgf)

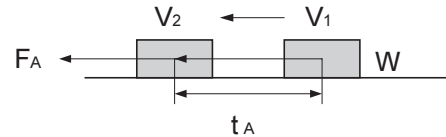

[SI Units]

$$F_A = m \cdot \alpha = m \cdot \frac{V_2 - V_1 \text{ (N)}}{t_A}$$

$$\alpha = \frac{V_2 - V_1}{t_A}$$

m: Mass (kg)

 α : Acceleration (m/s^2) t_A : Acceleration Time (s)

[Gravitational Units]

$$F_A = m \cdot \alpha = \frac{W}{g} \cdot \frac{V_2 - V_1 \text{ (N)}}{t_A}$$

$$\alpha = \frac{V_2 - V_1}{t_A}$$

W: Weight (kgf)

g: Acceleration of gravity ≈ 9.8 (m/s^2)m: Mass ($\text{kgf}\cdot\text{s}^2/\text{m}$) α : Acceleration (m/s^2) t_A : Acceleration Time (s)

6. Acceleration Torque T_A (N·m, kgf·m)

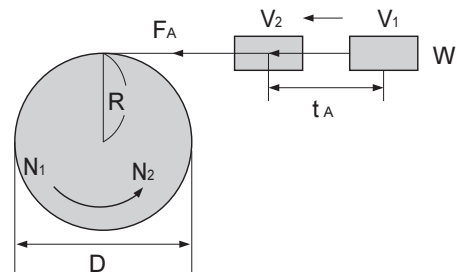

[SI Units]

$$T_A = F_A \cdot R \quad F_A = m \cdot \frac{V_2 - V_1}{t_A}$$

$$V_2 = \pi \cdot D \cdot \frac{N_2}{60} \quad V_1 = \pi \cdot D \cdot \frac{N_1}{60}$$

$$D = 2 \cdot R$$

$$\therefore T_A = m \cdot \frac{\pi \cdot 2 \cdot R}{60} \cdot (N_2 - N_1) \cdot R$$

$$= \frac{2 \cdot \pi \cdot m \cdot R}{60} \cdot \frac{N_2 - N_1}{t_A} \cdot R$$

$$= \frac{m \cdot R^2}{9.55} \cdot \frac{N_2 - N_1}{t_A} \text{ (N}\cdot\text{m)}$$

$$m \cdot R^2 = J \text{ (moment of inertia (kgm}^2\text{))}$$

$$\therefore T_A = \frac{J}{9.55} \cdot \frac{N_2 - N_1}{t_A} \text{ (N}\cdot\text{m)}$$

[Gravitational Units]

$$T_A = F_A \cdot R \quad F_A = \frac{W}{g} \cdot \frac{V_2 - V_1}{t_A}$$

$$V_2 = \pi \cdot D \cdot \frac{N_2}{60} \quad V_1 = \pi \cdot D \cdot \frac{N_1}{60} \cdot R = \frac{D}{2}$$

$$\therefore T_A = \frac{W}{g} \cdot \frac{\pi \cdot D}{60} \cdot (N_2 - N_1) \cdot \frac{D}{2}$$

$$= \frac{\pi \cdot W \cdot D}{60 \cdot g} \cdot \frac{N_2 - N_1}{t_A} \cdot \frac{D}{2}$$

$$= \frac{W \cdot D^2}{375} \cdot \frac{N_2 - N_1}{t_A} \text{ (kgf}\cdot\text{m)}$$

$$W \cdot D^2 = GD^2 \text{ (Flywheel effect (kgm}^2\text{))}$$

$$\therefore T_A = \frac{GD^2}{375} \cdot \frac{N_2 - N_1}{t_A} \text{ (kgf}\cdot\text{m)}$$

7. Synchronized Speed of AC Motor N_0 (r/min)

$$N_0 = \frac{120 \cdot f}{P} \text{ (r/min)}$$

f: Power supply frequency (Hz)

P: Number of motor poles

8. Rated Speed of AC Motor N (r/min)

$$N = N_0 (1 - s) \text{ (r/min)}$$

 N_0 : Synchronized speed (r/min)

s: Slippage

Lubrication

TECHNICAL
DATA

Common

Warranty Standard

Warranty Standard

Warranty period	Warranty for the CYCLO® DRIVE shall be 24 months from the shipment date, limited to new units.
Warranty Condition	<p>In the event that any problem or damage to the Product arises during the "Warranty Period" from defects in the Product whenever the Product is properly installed and combined with the Buyer's equipment or machines, maintained as specified in the maintenance manual, and properly operated under the conditions described in the catalog or as otherwise agreed upon in writing between the Seller and the Buyer or its customers; the Seller will provide, at its sole discretion, appropriate repair or replacement of the Product without charge at a designated facility, except as stipulated in the "Warranty Exclusions" as described below.</p> <p>However, if the Product is installed or integrated into the Buyer's equipment or machines, the Seller shall not reimburse the cost of: Removal or re-installation of the Product or other incidental costs related thereto, any lost opportunity, any profit loss or other incidental or consequential losses or damages incurred by the Buyer or its customers.</p>
Warranty Exclusions	<p>Notwithstanding the above warranty, the warranty as set forth herein shall not apply to any problem or damage to the Product that is caused by:</p> <ol style="list-style-type: none"> 1. installation, connection, combination or integration of the Product in or to the other equipment or machine that is rendered by any person or entity other than the Seller; 2. insufficient maintenance or improper operation by the Buyer or its customers, such that the Product is not maintained in accordance with the maintenance manual provided or designated by the Seller; 3. improper use or operation of the Product by the Buyer or its customers that is not informed to the Seller, including, without limitation, the Buyer's or its customers, operation of the Product not in conformity with the specifications, or use of lubricating oil in the Product that is not recommended by the Seller; 4. any problem or damage on any equipment or machine to which the Product is installed, connected or combined or on any specifications particular to the Buyer or its customers; 5. any changes, modifications, improvements or alterations to the Product or those functions that are rendered on the Product by any person or entity other than the Seller; 6. any parts in the Product that are supplied or designated by the Buyer or its customers; 7. earthquake, fire, flood, sea-breeze, gas, thunder, acts of God or any other reasons beyond the control of the Seller; 8. normal wear and tear, or deterioration of the Product's parts, such as bearings, oil-seals; 9. any other troubles, problems or damage to the Product that are not attributable to the Seller.

Warning

SAFETY PRECAUTIONS

- Observe safety rules for installation site and equipment strictly (Industrial Safety and Health Law, Technical Standard for Electric Facilities, Extension Rules, Plant Explosion guidelines, Building Standards Law, etc.)
- Read the maintenance manual carefully before use. Request one from the distributor you purchased from or our sales department if it is not handy. The maintenance manual must reach the actual user.
- Select an appropriate product to match the operating environment and application.
- Install protective equipment on the machine side when the machine is used for passenger transportation and elevators, escalators, and dumb waiters.
- Use a flameproof type motor for use in explosive environment. Select a flameproof type motor with appropriate specifications sufficient for hazardous locations.
- Either mount a control filter or a reactor on the inverter side or use a sufficiently insulated motor when a 400V class inverter is used to drive motor. Install an oil pan or other devices to prevent oil or grease leakage, just in case of failure or termination of service life, for oil-sensitive applications such as food processing and clean rooms.